

L. C. GOODALE.

Machine for Making Pipe-Elbows.

No. 126,884.

Patented May 21, 1872.

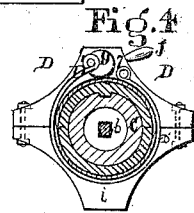
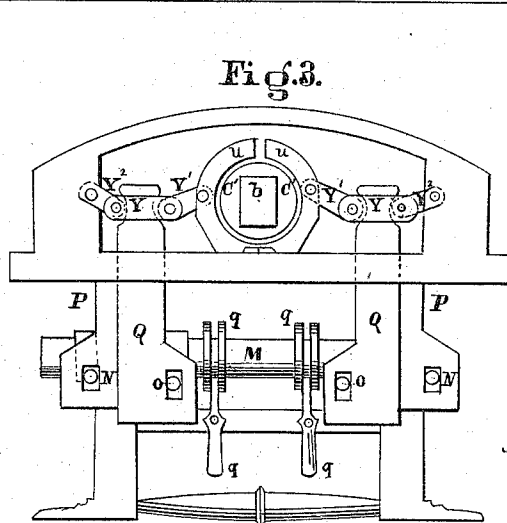
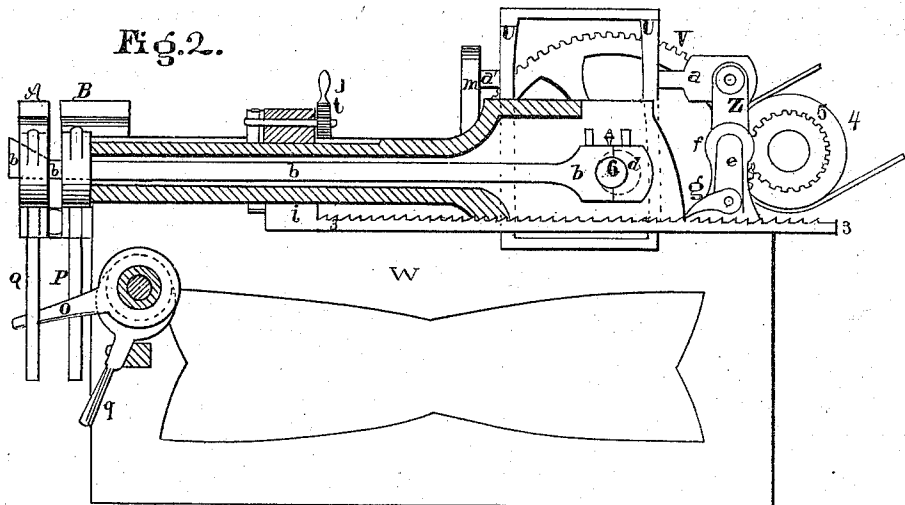
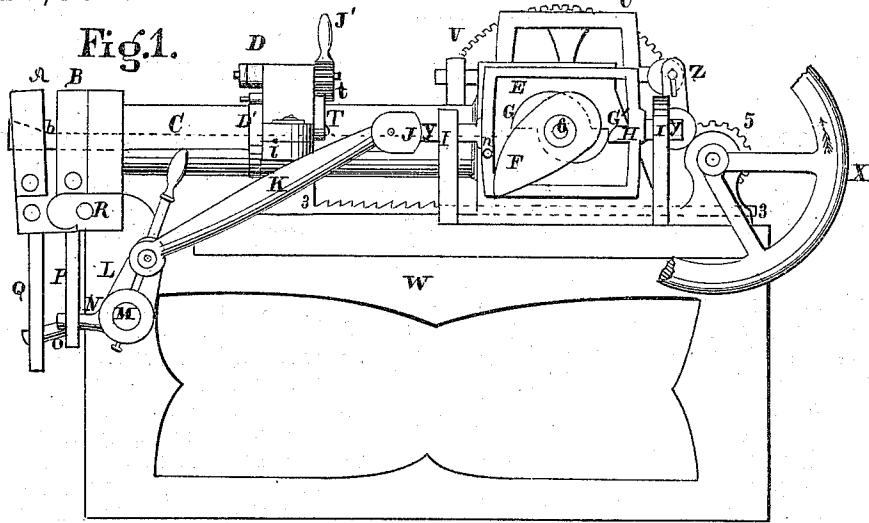

Attest.
Philip M. Shoup
Jeremiah T. Smith

Inventor.
L. C. Goodale

UNITED STATES PATENT OFFICE.

LEVI C. GOODALE, OF CINCINNATI, OHIO.

IMPROVEMENT IN MACHINES FOR MAKING PIPE-ELBOWS.

Specification forming part of Letters Patent No. 126,884, dated May 21, 1872.

I, LEVI C. GOODALE, of the city of Cincinnati, in the county of Hamilton and State of Ohio, have invented certain new and useful Improvements in Machinery for Making Pipe-Elbows, of which the following is a specification:

My invention in general relates to certain devices whereby a machine for making pipe-elbows, by crimping straight pipe, can be operated continuously by the application of rotary motion thereto. The machines in present use for the manufacture of such elbows admit of being operated by the hand alone—in other words, are hand-machines, the several functional parts of which must be operated separately by separate movements of the hand. My devices remedy this defect and enable such a machine to be operated by a hand-crank on a fly-wheel, or by belt or other rotary gear.

The first part of my invention relates to eccentrics or their equivalents, connected by intermediate devices to two sets of jaws in such a manner that the rotation of the eccentrics will cause one set of jaws to form the crimp on the pipe. The second part of my invention relates to a device having a continuous rotary movement, and operating cranks connected with a pawl in such a manner that at suitable times during the working of the machine the pawl will propel the pipe through the jaws and present a fresh portion of its surface for crimping. The third part of my invention relates to a device for attaching temporarily the pipe to the device for feeding said pipe to the jaws. The fourth part of my invention relates to the application of continuous rotary motion to the eccentric or lever operating the rod which draws up the outer jaws against the inner ones.

In the accompanying drawing, Figure 1 is a side elevation of one side of a machine embodying my improvements. Fig. 2 is a vertical longitudinal section through the center of the same. Fig. 3 is an elevation of that end of the machine which is on the left hand in Fig. 1; and Fig. 4 is an elevation of the front end of the device for attaching the pipe to the feeding device aforesaid.

W is the main frame of the machine. B is the frame of that set of jaws which form the preliminary crimp on the pipe, and is fixedly attached vertically to the front end of main

frame W. A is the frame of the set of jaws which form the preliminary crimp into a perfect crimp. This latter frame is affixed at its lower end to the front of the frame B by a pivot, R. C is a hollow cylinder, which supports the pipe while being fed to the jaws. D is a clamping device, to be hereafter described, for holding the pipe securely to the device for feeding the pipe forward. E is a link parallel with the length of the frame, and sliding horizontally and longitudinally on arms *y y*, which project from the middle of each end and are supported by pillars I I, by means of cam F. Link E is provided with stub *n*, which projects from the side of its front end, and with stub H, which projects from the inside of its rear end. The double eccentric G G' impinges against stub H and eccentric F against stub *n*. Arm *y*, on the front end of the link, extends beyond pillar I, and is there jointed at J to one end of a rod, K; the other end of this latter connects with a short lever, L, which is fixed to an axis, M, which passes horizontally through the machine at right angles to its length. Upon this axis M are attached levers *o o*, each of which operate to raise a secondary upright lever, Q, which latter raises or depresses a toggle-joint, Y Y¹ Y², (see Fig. 3.) This toggle-joint consists of a horizontal link, Y, and a link, Y², pivoted at one end to link Y and at the other to frame A, and further of a link, Y¹, pivoted at one end to Y and at the other to the side of one of the jaws *u*. That end of each link Y¹ or Y² which is toward the supplemental lever Q is rounded, and fits snugly into a rounded recess in the upper part of the side of this lever and against the inner side of such recess. This method of combining the link and the upright levers causes the upright levers Q Q when raised to close the jaws *u u* tightly upon disk C'. Upon axis M are also attached levers N N, which operate vertical supplemental levers P P, which latter, by means of toggle-joints made and attached similarly to the toggle-joints of frame A, operate the jaws of frame B and close them upon a bead upon the end of the cylinder C, thus forming the preliminary crimp.

The device for drawing the frame A close up against B consists of a rod, *b*, (see Fig. 2,) which passes through disk C', and has upon

its forward end a wedge, flaring upward and outward, and so adjusted that when drawn back it will tighten in the disk C' and draw it, with the jaws *u* and frame A, up to B. This rod extends through the center of the cylinder C, and is moved backward and forward by a lever or eccentric, *d*. This lever is attached to and revolves on axis 6. In the top of cylinder C, and for the greater portion of its length, is a slot, in which slides a tongue on the bottom of the top portion of the clamp, thereby preventing said clamp from slipping sidewise on the cylinder. The solid frame-work *i* of the clamp below the cylinder is attached to a rod, 3, having a ratchet in its upper side moved by a pawl, *g*, which is operated by a lever, *e*, upon an axis operated in turn by a second lever, *z*, which latter is moved by an arm, *a*, upon the middle of the rear side of a vertical longitudinally sliding link, U. The link U is parallel with the length of the machine, and is operated by an eccentric rotating upon the same axis as the eccentrics G, G', and F which move link E. D is a clamp, and consists of an annular ring, D', inclosing an annular shoulder upon the forward end of the frame-work *i*. One end of this ring is fastened at 7 to the said frame-work. The other end is attached to an arm upon the lower portion of the front end of a lever, 9. The latter is attached to a spindle, *t*, operated by handle J'. On the lower end of the handle is a half pinion, into which plays a pawl, T, which secures the clamp from unfastening. X is a fly-wheel for securing steady motion to the various axes of the machine. A band-wheel, 4, imparts power to the machine. A spur-wheel, 5, on the same axis with belt-wheel 4, is attached to or loosened from said axis by means of a clutch of any suitable form. The eccentrics on axle 6 receive their rotary motion from a cog-wheel, V, which meshes into spur-wheel 5.

The mode in which my improvements operate the machine is as follows: Pawl *g* is first lifted and the feeding device D *i* 3 is drawn back so that the clamp D is over the rear end of the cylinder. The jaws of both frames being open, the pipe which is to be made into an elbow is first inserted within the jaws of frame A, and then passed between the jaws of B, and then passed over cylinder C so far that its front end is between the frame A and frame B. The annular shoulder D' of the clamp is then inserted in the rear end of the pipe and the band of the clamp tightened thereon, so as to firmly hold the pipe to the feeding device. The pawl *g* is now dropped into the ratchet of bar 3, and the machine is ready for operation. The power of belt-wheel 4 and its axle is now applied to gear 5 by means of the clutch aforesaid. Gear 5 turns the larger spur-gear V in the direction of the arrow. This latter gear turns axle 6 and sets in motion the several eccentrics G G' F, the eccentric of link U, and lever *d*, the eccentrics for the purpose of this description being in the position shown in the drawing. The

levers O O are unshipped by means of clutches, so as to turn loosely on the axle M. The eccentric F strikes the stop *n* and presses the slide E forward, by which means a forward motion is communicated to the connecting-rod K, and thus to the lever L, which latter operates the axle M and depresses the levers N N. These levers open the jaws of frame B. As the machine continues to operate, the eccentric in link U strikes the rear end of said link, and, moving it backward, moves the lever *e* and pawl forward. The latter moves the feeding device forward one step, by which the pipe is fed forward, and that portion of the pipe whereon the first crimp is to be formed is brought between the jaws of frame B. Eccentric G' then strikes stub H of link U and draws said link back, thereby moving back lever L, but, as the levers O O are unclamped, does not elevate them, but does lift levers N N, and thereby lifts their toggle-joints and closes the jaws of frame B on the pipe, and thus forms the preliminary crimp. Lever *d* then immediately draws back rod *b*, and with it frame A; but as its jaws are unclamped they slip along the pipe, and frame A is brought against frame B without making any crimp on the pipe. The eccentric of link U again draws back pawl *g* a step on the ratchet; lever *d* now allows frame A to open. The pipe is then fed forward by the feeding device aforesaid, so that the preliminary crimp is brought between the two sets of jaws. The levers O O, which operate the toggle-joints of frame A, are then attached to the axle by means of the clutches *g g* aforesaid. Eccentric G then, striking stub H, operates to raise levers N N and O O, and thereby closes the jaws of frames A and B. Lever *d* again draws back bar *b*, and with it the jaws of frame A, against frame B. As both sets of jaws have firmly grasped the pipe, the effect of their being brought together is to press up the preliminary crimp and form it into a perfect crimp. The eccentric F now relaxes the jaws of the frames A and B, and the feeding device feeds the pipe another step forward. These afore-described operations are repeated until the desired number of crimps are formed upon the pipe. Then, when the jaws are open, the machine is stopped by disengaging the gear-wheel 5 from the belt-wheel. The pipe is now removed, and a fresh pipe, which is to be made into an elbow, placed in the machine. The aforesaid process is then repeated. The machine, however, need not be stopped in order to remove the pipe-elbow from it or to insert fresh pipe in it. This desirable result is accomplished in the following manner: That journal-box of the rod K which fits on the journal of lever L is open at the bottom, thereby allowing the rod to be lifted from its journal. By so lifting said rod and working lever L with the hand, (for which purpose it is provided with a handle,) the axis M and both sets of jaws can be opened or closed and the pipe inserted or removed while the machine is in full operation.

After the adjustment of the pipe the rod is again affixed to the journal, when the machine will again operate the jaws.

What I claim as new is—

1. Toggle-joints to open and close the jaws, substantially as and for the purposes set forth.
2. In combination with suitable devices for opening and closing the jaws, I claim the axle M, provided with levers, or their equivalents, for operating said devices.
3. The lever L, in combination with the axle M provided with levers for operating the devices for opening and closing the jaws, substantially as and for the purposes set forth.
4. The rod K, when employed to connect the devices for opening and closing the jaws, and the devices for imparting motive power to the same.
5. The eccentrics G G', in combination with the devices for tightening the jaws, substantially as and for the purposes specified.
6. The combination of the eccentrics G G' F and the link E, all in combination with devices for tightening and loosening said jaws.
7. The combination of eccentrics G G' F, link E provided with stubs H and n, and connecting-rod K, lever L, axle M, levers N N and O

O, upright levers P P Q Q, toggle-joints Y Y¹ Y², and jaws, substantially as and for the purposes specified.

8. The application of continuous rotary motion to lever or eccentric d, substantially as and for the purposes specified.

9. The eccentric of link U, in combination with devices for moving pawl g forward and backward so as to feed the pipe forward.

10. The combination of the eccentric and its link U, levers Z and e, pawl g, and ratchet-bar 3 of the feeding device, substantially as and for the purposes set forth.

11. In combination with axle 6, the eccentrics or any equivalent devices for feeding the pipe to the jaws for drawing up the outer jaws to form the crimp, and for opening and closing the jaws, whereby these various operations are performed by the revolution of a single shaft, substantially as specified.

12. The clamp D, composed of ring D', lever 9 on spindle t, lever J' provided with pinion, and pawl T, for the purpose set forth.

LEVI C. GOODALE.

Witnesses:

PHILIP M. SHUEY,
J. TROOHIG.