

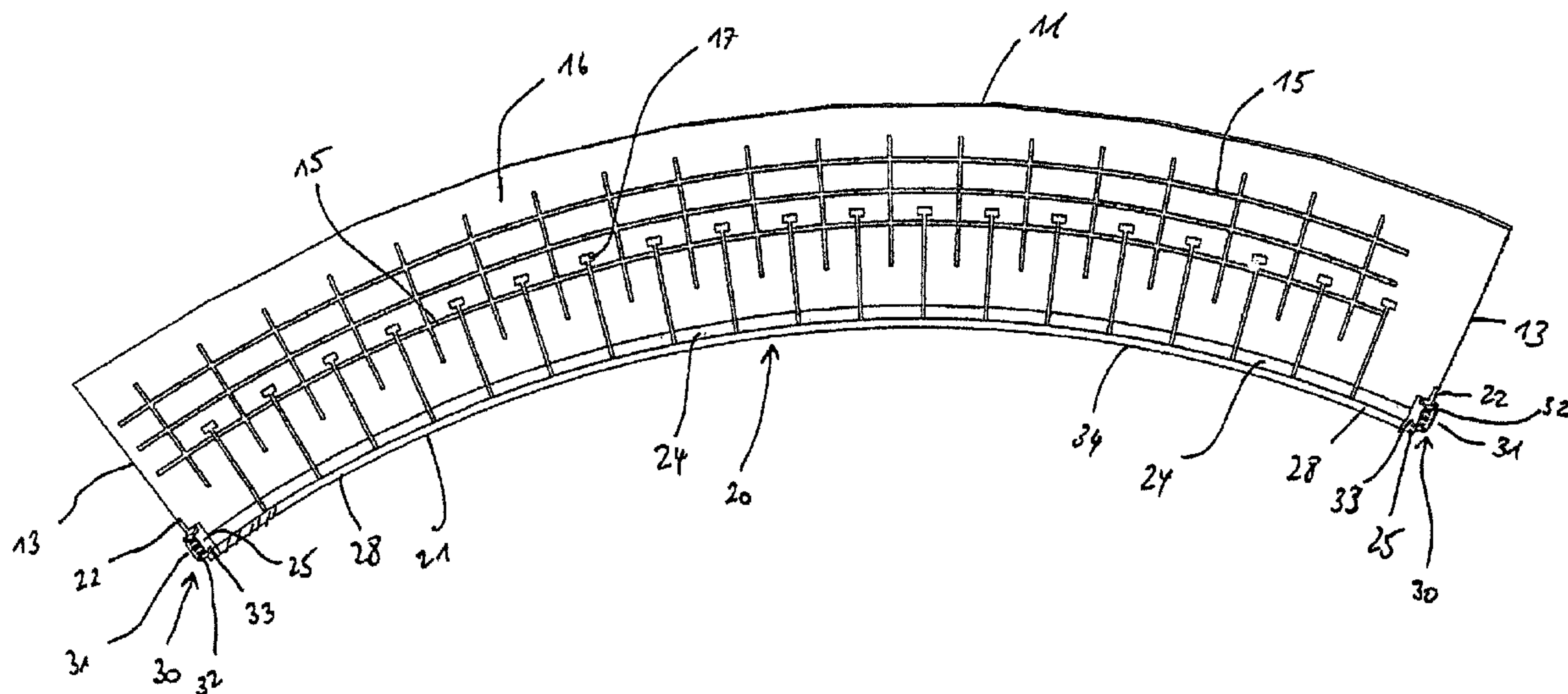

(86) Date de dépôt PCT/PCT Filing Date: 2015/02/18
 (87) Date publication PCT/PCT Publication Date: 2015/09/10
 (45) Date de délivrance/Issue Date: 2017/05/09
 (85) Entrée phase nationale/National Entry: 2015/07/08
 (86) N° demande PCT/PCT Application No.: EP 2015/000364
 (87) N° publication PCT/PCT Publication No.: 2015/139807
 (30) Priorité/Priority: 2014/03/21 (EP14001047.1)

(51) Cl.Int./Int.Cl. *E21D 11/08* (2006.01),
E21D 11/18 (2006.01), *E21D 11/38* (2006.01)
 (72) Inventeurs/Inventors:
RECHER, GILLES, FR;
ALLAIN, SYLVAIN, FR;
RIECHERS, JORG, DE
 (73) Propriétaire/Owner:
HERRENKNECHT AG, DE
 (74) Agent: RIDOUT & MAYBEE LLP

(54) Titre : ELEMENT PROTECTEUR, ELEMENT EN CIMENT ET METHODE DE PRODUCTION D'UN ELEMENT EN CIMENT
 (54) Title: PROTECTIVE ELEMENT, CONCRETE ELEMENT, AND METHOD FOR PRODUCING A CONCRETE ELEMENT



(57) Abrégé/Abstract:

The invention relates to a protective element for connecting to a concrete element (10) of a tunnel lining and having at least one protective portion (21, 22, 23) which has a side which faces the concrete element (10) and on which is provided at least one connecting element (24, 25, 26, 27, 28) for producing a durable connection of the protective portion (21, 22, 23) to the concrete element (10), wherein the protective portion (21, 22, 23) has a base portion (21) and/or a wall portion (22, 23) and at least one region consisting of at least one plastics material, and the protective element has at least one seal (30) which is connected in a single piece to the protective portion (21, 22, 23), wherein the connection is gas-tight and liquid-tight, and the single-piece connection of the seal to the protective portion is produced by injection moulding with the at least one plastics material and thereby forms a first portion of the base portion (21) and/or of the wall portion (22, 23) of the protective portion (21, 22, 23). With respect to the protective element, the base portion (21) and/or the wall portion (22, 23) of the protective portion (21, 22, 23) have/has at least one second portion, wherein the second portion has an areal extent, and the second portion is connected to the first portion by injection moulding.

Abstract

The invention relates to a protective element for connecting to a concrete element (10) of a tunnel lining and having at least one protective portion (21, 22, 23) which has a side which faces the concrete element (10) and on which is provided at least one connecting element (24, 25, 26, 27, 28) for producing a durable connection of the protective portion (21, 22, 23) to the concrete element (10), wherein the protective portion (21, 22, 23) has a base portion (21) and/or a wall portion (22, 23) and at least one region consisting of at least one plastics material, and the protective element has at least one seal (30) which is connected in a single piece to the protective portion (21, 22, 23), wherein the connection is gas-tight and liquid-tight, and the single-piece connection of the seal to the protective portion is produced by injection moulding with the at least one plastics material and thereby forms a first portion of the base portion (21) and/or of the wall portion (22, 23) of the protective portion (21, 22, 23). With respect to the protective element, the base portion (21) and/or the wall portion (22, 23) of the protective portion (21, 22, 23) have/has at least one second portion, wherein the second portion has an areal extent, and the second portion is connected to the first portion by injection moulding.

- 1 -

Protective element, concrete element, and method for
producing a concrete element

Description

5

The invention relates to a protective element for connecting to a concrete element of a tunnel lining and having at least one protective portion which has a side which faces the concrete element and on which is provided at least one connecting element for producing a durable connection of the protective portion to the concrete element, wherein the protective portion has a base portion and/or a wall portion and at least one region consisting of at least one plastics material, and the protective element has at least one seal which is connected in a single piece to the protective portion, wherein the connection is gas-tight and liquid-tight, and the single-piece connection of the seal to the protective portion is produced by injection moulding with the at least one plastics material and thereby forms a first portion of the base portion and/or of the wall portion of the protective portion.

Such concrete elements and/or protective elements are known from WO 2011/085734 A1. Such concrete elements are also referred to in specialist circles as "tubbing" and are used, for example, in mechanized shield tunnelling. Use is made here, for example, of tunnelling boring machines which comprise a boring head, behind which is arranged a cylindrical shield with a shield skin and a shield tail. The shield has a smaller external diameter than the boring head, and there is therefore no direct contact between the tunnel wall and shield. When the tunnelling boring machine has advanced a certain distance, the concrete elements are positioned on the shield periphery in the tail of the shield. They are

- 2 -

pressed, counter to the advancement direction, onto the adjacent, last-fitted concrete element and connected thereto. A plurality of concrete elements together form a ring over the entire circumference of the tunnel. The gap
5 between ring and tunnel wall is filled with cement, for example in order to prevent settling.

This method of tunnel construction is also used, inter alia, for constructing wastewater lines, in particular
10 relatively large collecting lines. As is also the case for other possible use purposes, the sealing of the casing of the tunnel here is subject to stringent requirements. The inner side of the tubbings is sealed by a casing, and therefore it is not possible for any
15 wastewater, or any gases rising up from the wastewater, to pass into the concrete via the tunnel walls and to damage same (corrosion).

WO 2005/024183 A1 and also JP 2004 132 002 disclose that
20 the tubbings used for the tunnel lining are produced beforehand, and that a casing is arranged on the inner side of the tubbings as the latter are being produced, this casing, when the individual tubing rings are in the assembled state, sealing the tunnel wall against water
25 and gases. The concrete element here has provided on it a protective layer, which covers an inner surface of the tubing, this inner surface being located opposite a convex outer surface. This protective layer consists, according to WO 2005/024183 A1, of glass-fibre plastics
30 material or polyethylene (PE) or, according to JP 2004 132 002, of a synthetic resin and, in this case, in particular of polyethylene (PE), polypropylene (PP), PVC, polyester or vinylester and is anchored firmly in the concrete by mechanical anchoring means, and therefore
35 the protective layer is connected inseparably to the concrete. The protective layer here is designed such that

- 3 -

only the inner side of the tubbing element is covered (JP 2004 132 002) or else a side surface of the concrete element is likewise also partially enclosed (WO 2005/024183 A1).

5

According to WO 2005/024183 A1, a seal, which projects beyond the protective layer, is then provided on the side surface. The seal is produced from an elastic material, and therefore, when the individual tubbings are being assembled to form the tunnel lining, the joints between the adjacent concrete elements are closed by the seal.

10

The concrete element of WO 2005/024183 A1 itself is produced by means of a formwork. A protective layer is positioned on the base of the formwork. Furthermore, likewise protective-layer elements are placed on the side walls of the formwork. The formwork also has an aperture, into which the seal is inserted. The concrete is then introduced into the formwork, in conjunction with reinforcement. Once the concrete has set, the tubbing is used as tunnel lining.

15

20

WO 2011/085734 A1 shows an improvement to this. It has been found, in practice, in the arrangement according to WO 2005/024183 A1 that leakage can occur in the transition between the protective layer and seal where sufficient care has not been taken, during the production of the concrete element, in respect of inserting the seal into the formwork and/or in respect of arranging the seal in relation to the protective layer. As a solution for this, WO 2011/085734 A1 shows that the protective element is produced in an injection mould in which the seal is inserted and is enclosed by the inserted plastics material, with the result that a liquid-tight and gas-tight connection between the seal and protective element is produced. Polydicyclopentadiene (pDCPD) is disclosed

30

35

- 4 -

as a particularly advantageous plastics material for encapsulating the seal.

5 It is therefore an object of the invention to provide a production method for a concrete element and an improved protective layer in which the protective element is improved in terms of the use of material while having sufficient adhesion.

10 With respect to the protective-layer element, the object according to the invention is achieved in that the base portion and/or the wall portion of the protective portion have/has at least one second portion, in that the second portion has an areal extent, and in that the second
15 portion is connected to the first portion by injection moulding.

It has been surprisingly found when searching to improve the above-described protective element that it is
20 possible to connect at least one prepared portion of the protective element to the injection-mouldable plastic in such a way that sufficient sealing of the protective element can be achieved. At the same time, it is thus possible in a simple manner for the production costs of
25 the protective element to be lowered since it is possible to reduce the amount of injection-moulding material and thus to simplify the production and the injection mould.

Injection moulding is to be understood here as all
30 methods which can be subsumed under injection moulding, that is to say methods in which one or more thermoplastics/thermosets/elastomers, for example as polymers or else a monomers, are introduced directly into a mould alone, individually, successively or
35 simultaneously (for example overmoulding or multi-component injection moulding), or in which monomers are

- 5 -

processed which only become polymers in the injection mould (for example reaction overmoulding).

5 A further teaching of the invention provides that the second portion essentially consists of a film, a plate or a sheet which is preferably connected to connecting elements, and/or that the second portion is formed from a further plastics material, preferably a thermoplastic material.

10 A further teaching of the invention provides that the base portion of the protective portion is essentially formed from the second portion, and/or that the connection between the first and second portion is a butt joint, or that the first portion at least partially encloses the second portion in
15 certain portions. This makes it possible for the injection moulding to be limited essentially to the direct connection of the base portion to the seal. Preferably, the first portion is a thermoset polymer material. A liquid-tight and gas-tight connection is produced in a particularly simple manner by the
20 single-piece connection of the seal and of the connecting elements to the protective portion. The injection moulding can ensure that the protective elements are produced with a consistently high quality, and therefore, in respect of the completed concrete element, the protective action of the
25 protective element is particularly high and of a consistently high quality, irrespective of the process used for producing the concrete element. The protective element here is formed such that, in relation to the seal, the injection-moulding material encloses the material of the seal at least on three
30 sides.

A further teaching of the invention provides that the connecting element is a honeycomb structure, a crosspiece, a pin and/or a sheet-like element with openings. Furthermore, it
35 is advantageous for the

- 6 -

protective portion to be connected in a single piece to
the at least one connecting element, wherein preferably
the single-piece connection is produced by injection
moulding the plastics material. In particular sheet-like
5 elements such as honeycomb structures or sheet-like
portions with through-openings allow the protective
element to be anchored to particularly good effect to the
concrete element over the entire surface area of the
protective element. The additional provision of pins or
10 the like, which extend possibly further into the concrete
of the concrete element, can give rise to an enhanced
increase in the retaining force at certain points. Since
it is provided that, in the case of the concrete element
being damaged, and thus of water pressure possibly
15 prevailing from the outside, the protective element
should be fully capable of withstanding the water
pressure, it is also particularly advantageous if the
shape and the choice of material of the connecting
elements are freely available, and if, in particular in
20 the case of connecting elements which do not consist of
plastics material, the injection moulding can provide for
a corresponding connection between connecting element and
protective portion. Furthermore, for the case where the
connecting elements of the injection-moulded portion of
25 the protective portion are likewise produced from the
same plastics material as the protective element, the
injection moulding makes it possible to provide for a
particularly wide variety of shapes for the connecting
elements. Furthermore, it is possible for the connecting
30 elements to be produced by extrusion when producing the
respective portion of the protective portion.

A further teaching of the invention in this context
provides also for a ceiling element, this therefore
35 resulting in a hollow body, into which the concrete and
possibly, during the injection-moulding operation,

- 7 -

reinforcement are then introduced. This is advantageous, in particular, if the concrete element also has to have its outer sides protected against aggressive waters in the ground.

5

A further teaching of the invention provides that the plastics material is a polydicyclopentadiene (pDCPD), preferably in a form which is resistant to high temperatures, or a resin, wherein reinforcing elements, for example glass fibres, may possibly be added to the plastic resin. This plastics material makes it possible to achieve a high production speed, on account of the rapid processing properties. A particularly high resistance during use is achieved at the same time.

15

A further teaching of the invention provides that the plastics material of the sheet-like element is a thermoplastic, preferably PE. These plastics materials are particularly cost-effective plastics materials. Components made from them, for example plates, sheets or films, can be produced directly in situ in a decentralized manner, and therefore there is no need for considerable transportation expenditure and possibly also storage expenditure for the completed products.

25

In respect of the concrete element for producing a tunnel lining, the teaching of the invention provides that an above-described protective element is used. Such a protective element makes it possible to achieve sufficient joint sealing, which provides corresponding sealing of the protective coating of the tunnel against liquids and gases.

30

In respect of the production method according to the invention, the solution of the invention provides that a protective element described above is produced from a

35

- 8 -

plastics material by injection moulding, the completed protective element is inserted into a mould, and the protective element is connected to concrete and, once setting has taken place, is removed from the mould. The
5 prefabrication of the protective element by injection moulding, in the case of which the retaining elements and seal are connected in a single piece to the protective portion of the protective element, provides for a simple production method because the above-described possible
10 sources of error in the production of the concrete element are eliminated, since all that is required is for a single component to be introduced into the formwork, and therefore the source of error in the transition between protective layer and seal is eliminated. At the
15 same time a connection with a high retaining force between the protective element and concrete element is provided in a simple manner. It is advantageous here if sufficient protective action, of consistent quality, is provided for the concrete elements even if the concrete
20 elements are produced in situ at the sight of use of the tubbings.

Furthermore, it may be advantageous if the upper side of the concrete elements is also provided with a protective
25 element or a protective layer. It is possible here for this protective element or the protective layer to be provided even before the concrete is fed into the formwork or else thereafter, for example by being coated on or the like.

30

The invention will be explained in more detail hereinbelow with reference to drawings, in which:

Figure 1 show a first three-dimensional view of a
35 concrete element according to the invention,

- 9 -

Figure 2 shows a second three-dimensional illustration of the concrete element according to the invention,

5 Figure 3 shows a side view of the concrete element according to the invention,

Figure 4 shows a sectional view through the concrete element according to the invention,

10 Figure 5 shows an enlarged detail of a sectional view of a corner region according to Figure 4, and

15 Figures 6 to 9 show various embodiments of the protective element according to the invention.

A concrete element 10 according to the invention (Figure 1 to Figure 3) is a segment portion (tubbing) of a tunnel lining. The segment portion has a convex upper side 11 and an underside 12 (concealed by a protective element 20 in 20 Figures 1 to 3) arranged opposite the upper side. The protective element 20 is arranged on the inner side 12 of the concrete element. The protective element 20 has a base portion 21 and wall portions 22, 23. An accommodating region 29, in which a seal 30 is arranged, is provided on these 25 wall portions 22, 23. The connection between seal 30 and protective element 20 is obtained by injection moulding.

The protective element 20 has on its wall portions 22, 23 a first portion 25 consisting of an injection-mouldable 30 plastics material, such as a thermoset material polymer. The base portion 21 has a second portion 28 with an areal extent.

The concrete element 10 is illustrated in section in Figure 35 4 with a first embodiment of the protective

- 10 -

element 20 according to the invention. Figure 5 shows an enlarged detail of the corner region of Figure 4. Further embodiments of the protective element 20 are illustrated in Figures 6 to 9.

5

The protective element 20 has, as illustrated in Figure 4, a base portion 21, on the outer sides of which wall portions 22, 23 are arranged essentially at right angles, although they may also be in any other desired arrangement. In order to produce a durable connection between the protective element 20 and the concrete element 10, the inner side of the base portion 21 has pin elements 17. As an alternative (not illustrated), it is also possible for crosspieces to be arranged parallel to one outer wall and for crosspieces 28 to be arranged parallel to the outer wall arranged at right angles thereto. The crosspieces can, for example, be provided with openings, through which the concrete 16 can pass and thus once it has set, produces a particularly durable connection. In order to achieve a durable connection of the wall portions 22, 23, a protrusion 27 is provided, this being positioned on the wall portion 22, 23 at an angle of 45-90° and being provided with openings 26 likewise in order to produce a durable connection.

15
20
25

The seal 30 is arranged in an accommodating region 29. The seal 30 consists of an elastic plastics material. The seal 30 has a sealing surface 31 which, when the individual concrete elements are being assembled, comes into contact with either another concrete surface or another sealing surface 31 of a seal 30. The seal 30 has chambers 32 in its interior. When the concrete elements 10 are being assembled, the elastic plastics material of the seal 30 is deformed and the chambers 32 are compressed. Retaining protrusions 33 are arranged opposite the sealing surface 31, and engage in the

30
35

- 11 -

plastics material of the side wall 22, 23 of the protective element 20. These retaining protrusions and the nearby sidewalls of the seal 30 become connected to the plastics material of the protective element during injection moulding or are surrounded thereby in a gas-tight manner.

In the embodiment of the protective element 20 according to Figure 4, a honeycomb structure 24 is arranged on the inner side of the base portion 21 of the protective element 20. This honeycomb structure can, for example, be adhesively bonded to the base portion 21 or be anchored in some other way. When the concrete 16 is introduced into the protective element 20, concrete 16 can penetrate into the honeycomb structure 24 and set there. The high surface of the honeycomb structure 24 provides for a large contact surface area between the honeycomb structure 24 and concrete 16, and therefore high retaining forces are present once the concrete 16 has set. The honeycomb structure 24 is assisted by further connecting elements, which are likewise in the form of crosspieces (not illustrated), or pin elements 17. It is possible for the crosspieces and/or pins 17 to be formed from a plastics material of the protective element 20 or as an alternative, or in addition, for these to be provided from other material, for example metal.

In Figure 4, a reinforcement 15 is provided in addition to the connecting elements in the form of pins 17. The reinforcement either, as illustrated in Figure 4, rests on the connecting elements 17 or, as an alternative, can also rest on the honeycomb structure 24 or the base portion 21. Figure 5 shows a section through a concrete element according to the invention. The reinforcement 15 here, just like the honeycomb structure 24 and the

- 12 -

crosspieces and/or pins 17, is surrounded by the concrete 16.

As is illustrated in Figure 4, the protective element has a first portion 25 which is obtained by injection moulding and comprises the seal 30. This first portion is produced from an injection-mouldable material, preferably a thermoplastic material, during injection moulding. Furthermore, the base portion 21 has a second portion 28 of the protective element 20. This is a sheet-like element 34, for example in the form of a sheet, film or plate. Integral components in this embodiment of the second portion 28 are T-shaped pin elements 17. These are either arranged on the sheet-like element or the pin elements 17 consist of the same material as the sheet-like element 34. The connection of the sheet-like element 34 is achieved by injection moulding of the first portion 25.

Figure 6 to Figure 9 show various exemplary ways of connecting the second portion 28 to the first portion 25. This connection can take the form of a butt joint (Figures 6, 7 and 9) or the second portion 28 is enclosed by the first portion on one side (not illustrated) or on both sides (Figure 8). In Figure 9, the sheet-like element forming the second portion 28 is provided not only as a component of the base portion 21 but also as the wall portion 22, 23. The connection in the form of a butt joint, as illustrated in Figures 6, 7 and 9, has surprisingly proved to be sufficient in particular when connecting PE as sheet-like element 34 and pDCPD as injection-mouldable plastics material of the first portion 25. Depending on the particular requirement placed on the protective element, it is also possible to provide a plurality of sheet-like portions 34 possibly consisting of different materials which are then connected via a plurality of first portions 25 to one

- 13 -

materials. This applies for the base portion 21, wall portion 22, 23 and ceiling portions.

A concrete element 10 according to the invention is produced by providing a formwork which is in the shape of the subsequent concrete element. Depending on the shape of the individual tunnel-lining elements 10, the exterior shape here may be a circle-segment portion. The plan view may be, for example, either rectangular or trapezoidal. This formwork has inserted into it a prepared protective element 20 which, during its production, was connected in a single piece to the seal 30. Following insertion of the protective element 20, the reinforcement 15 is inserted into the formwork, and the concrete 16 is cast in place.

15

As an alternative, the protective element 20 may be configured such that it is a hollow body into which the concrete is introduced, as a result of which it is possible to dispense with the formwork. The reinforcement 15 is then introduced during production of the hollow body or is introduced into the hollow body together with the concrete (fibre reinforcement).

20

The protective element 20 is produced by an injection mould, which is representative of the shape of the protective element 20, being created. The seal 30 is then positioned in the injection mould, in the accommodating region 29 provided for this purpose. Furthermore, the area elements 34 are inserted into the mould either as base portion 21 or as part of the base portion 21 and/or as part of the wall portions 22, 23. In addition, further connecting means and/or reinforcement 15 can be introduced into the injection mould, provided that these are to be produced from a material different from the protective element itself. The injection-mouldable plastics material is then introduced into the injection

30

35

- 14 -

mould. Once the plastics material has hardened, the protective element 20 can be removed from the mould and supplied for producing the concrete element 10.

5 The side walls 13 of the concrete element 10 contain cavities (not illustrated), into which are inserted brackets (not illustrated), in which bolts (not illustrated) are arranged in order to connect the individual concrete elements 10 to one another to form a
10 ring. The seals 30 of the concrete elements 10 connected to one another via the bolts butt against one another and are pressed together, and therefore they fully seal the gap or the joint between the two concrete elements 10. When the concrete elements 10 according to the invention
15 are used for casing a tunnel, there is therefore no need to provide any sealing for the joints between the concrete elements 10.

Also provided are guide holes (not illustrated), into
20 which guide rods (not illustrated) can be inserted. The guide holes are provided either in the side walls 14 of the concrete elements 10 or in the form of a half-element in the side walls 13. When two concrete elements are assembled via the bolts, these half-segments then form
25 the guide hole. With the aid of the guide rods, the concrete elements 10 of the following lining ring of the tunnel lining can be exactly positioned in a simple manner, since these elements likewise have the guide holes and the guide rods are then introduced into the
30 guide holes.

List of Designations

10	Concrete element
11	Upper side
12	Underside
13	Side wall
14	Side wall
15	Reinforcement
16	Concrete
17	Pin element
20	Protective element
21	Base portion
22	Wall portion
23	Wall portion
24	Honeycomb structure
25	First portion
26	Opening
27	Protrusion
28	Second portion
29	Accommodating region
30	Seal
31	Sealing surface
32	Chamber
33	Retaining protrusion
34	area element

CLAIMS:

1. Protective element for connecting to a concrete element (10) of a tunnel lining having at least one protective portion (21, 22, 23) which has a side which faces the concrete element (10) and on which at least one connecting element (24, 25, 26, 27, 28) is provided for producing a durable connection of the protective portion (21, 22, 23) to the concrete element (10), wherein the protective portion (21, 22, 23) has a base portion (21) and a wall portion (22, 23), and at least one region consisting of at least one plastics material, wherein the protective element has at least one seal (30) which is connected in a single piece to the protective portion (21, 22, 23), wherein the connection is gas-tight and liquid-tight, and the single-piece connection of the seal to the protective portion is produced by injection moulding with the at least one plastics material and thereby forms a first portion of the protective portion (21, 22, 23), characterized in that part of the protective portion (21, 22, 23) is at least one second portion, the second portion being an area element, and in that the second portion is connected to the first portion by injection moulding, and in that the first portion is formed from a thermoset polymer material and the second portion is formed from a thermoplastic material.
2. Protective element according to Claim 1, characterized in that the second portion essentially consists of a film, a plate or a sheet.
3. Protective element according to Claim 2, characterized in that the film, the plate, or the sheet is connected to connecting elements.
4. Protective element according to any one of Claims 1 to 3, characterized in that the base portion (21) of the protective portion (21, 22, 23) is essentially formed from the second portion.
5. Protective element according to any one of Claims 1 to 4, characterized in that the connection between the first and second portion is a butt joint.
6. Protective element according to any one of Claims 1 to 4, characterized in that the first portion at least partially encloses the second portion in certain portions.

- 17 -

7. Protective element according to any one of Claims 1 to 6, characterized in that the connecting element is a honeycomb structure (24), a crosspiece (25), a pin or a sheet-like element (25, 27, 28) with openings (26).
8. Protective element according to any one of Claims 1 to 7, characterized in that the protective portion (21, 22, 23) is connected in a single piece to the at least one connecting element (24, 25, 26, 27, 28).
9. Protective element according to any one of Claims 1 to 8, characterized in that the thermoset polymer material is a polydicyclopentadiene (pDCPD), or a resin.
10. Protective element according to Claim 9, characterized in that glass fibres are introduced into the resin.
11. Protective element according to any one of claims 2 to 10, characterized in that the plastics material of the thermoplastic material is polyethylene (PE).
12. Concrete element for producing a tunnel lining and having a convex outer surface (12) and an inner surface (12) located opposite, wherein a protective element (20) is connected to the inner surface (12) via at least one connecting element (24, 25, 26, 27, 28), characterized in that the protective element (20) is a protective element according to any one of Claims 1 to 11.
13. Method for producing a concrete element according to Claim 12, in which a protective element (20) according to any one of Claims 1 to 13 is produced from plastics material by injection moulding, the completed protective element (20) is inserted into a mould, and the protective element (20) is connected to concrete (16) and, once setting has taken place, is removed from the mould.

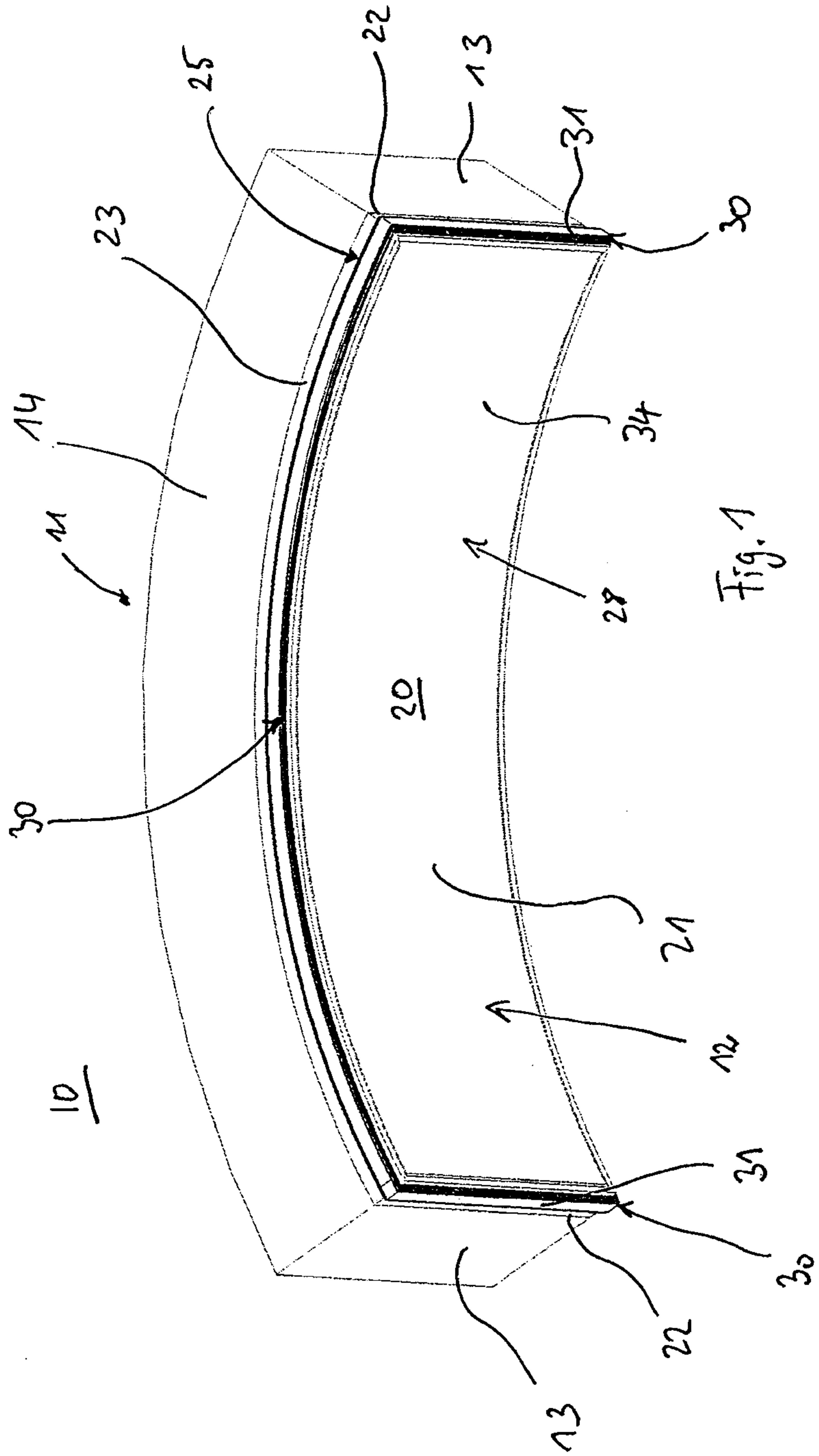

Fig. 1

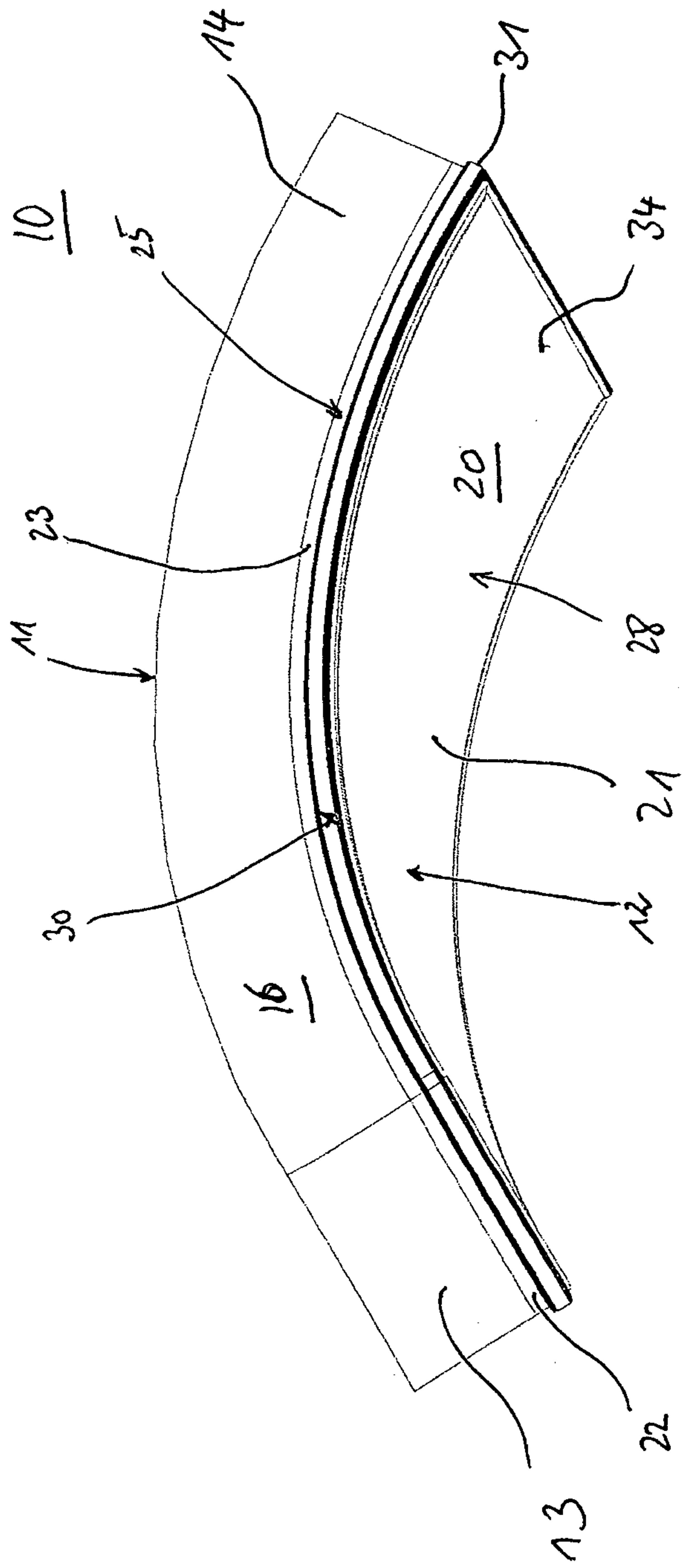
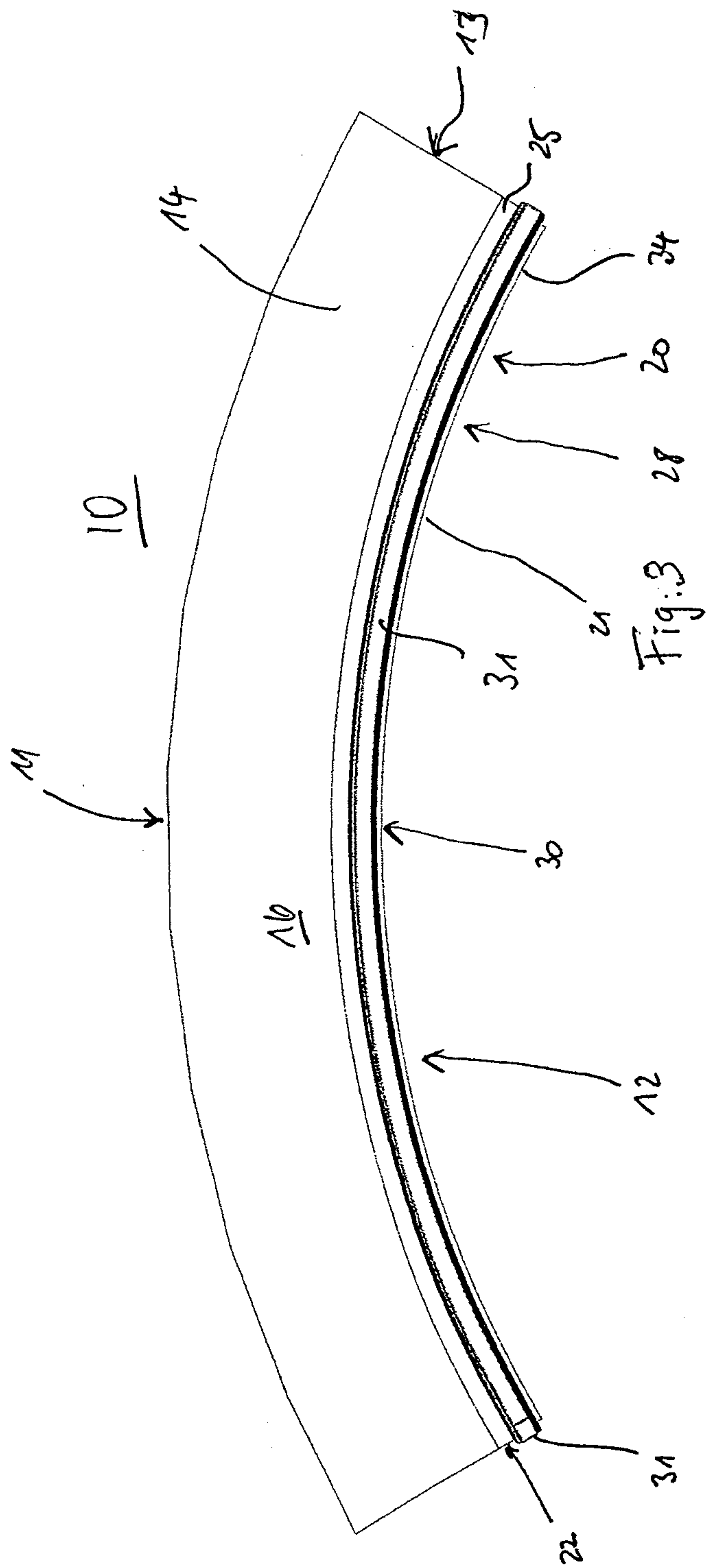

Fig. 2



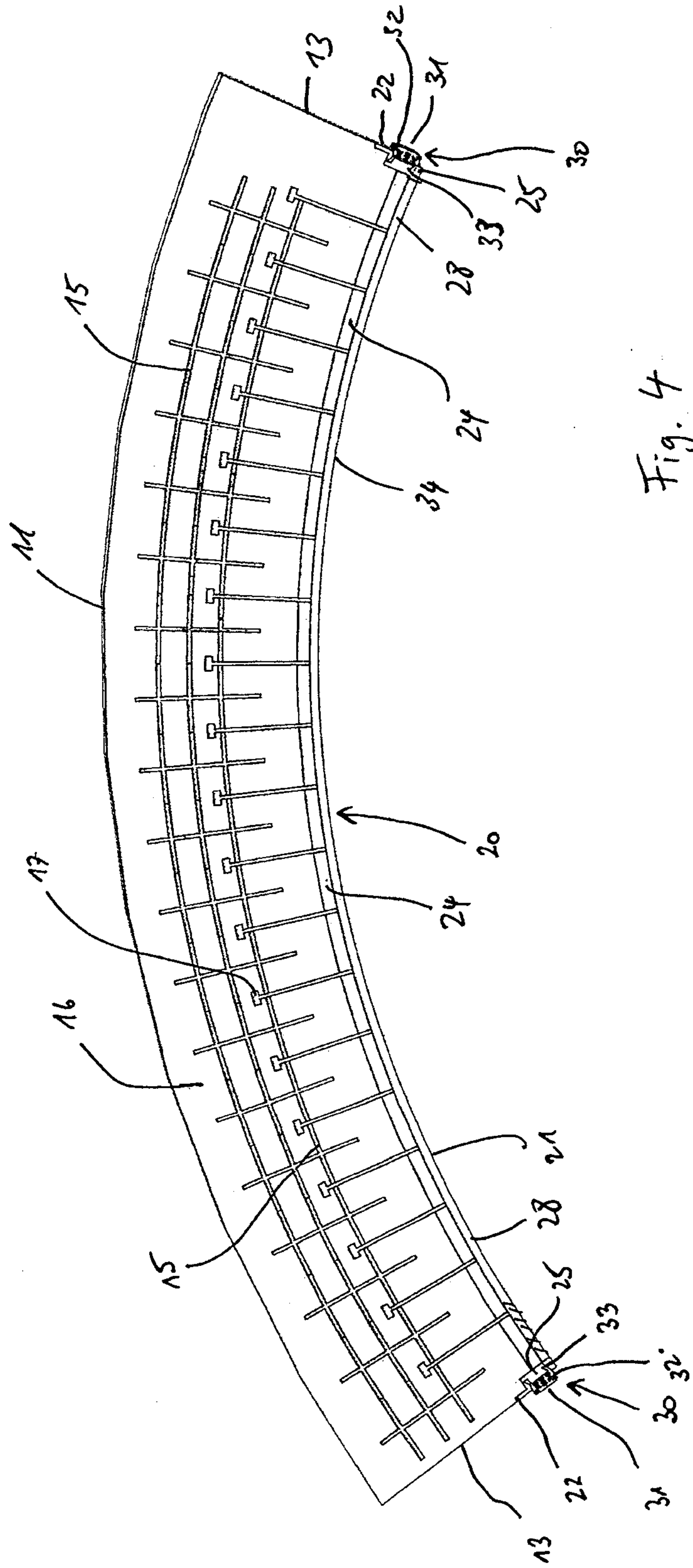

Fig. 4

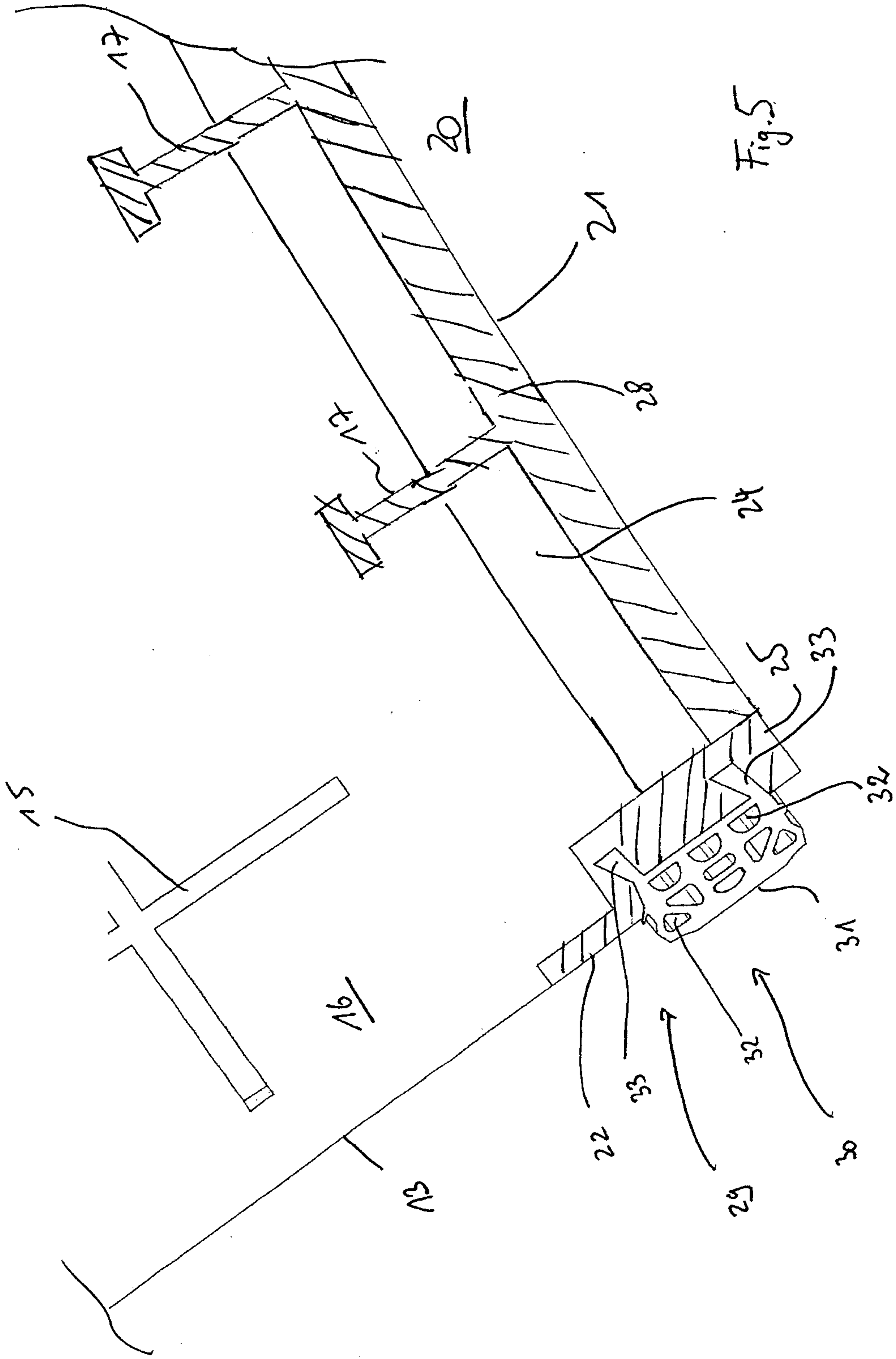

Fig. 5

