

(No Model.)

W. FENNER.
CLOTHES DRIER.

No. 266,800.

Patented Oct. 31, 1882.

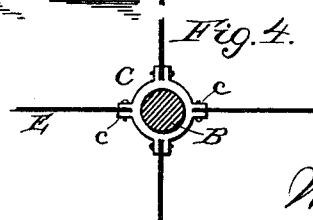
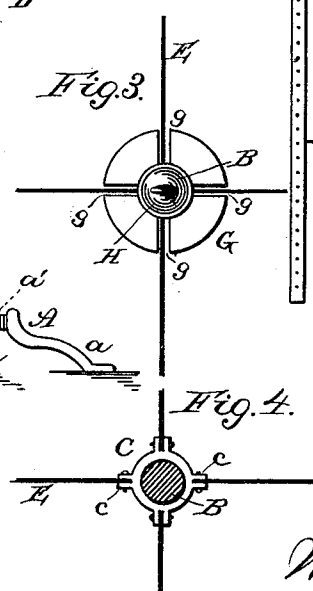
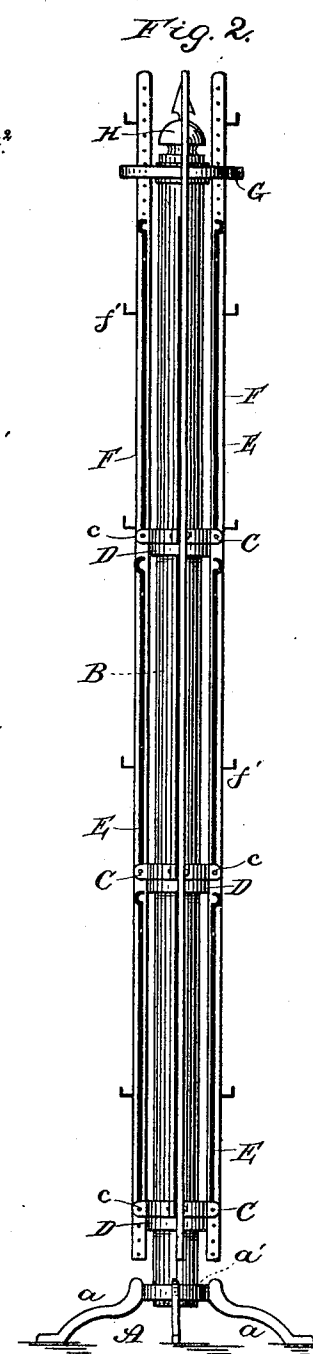
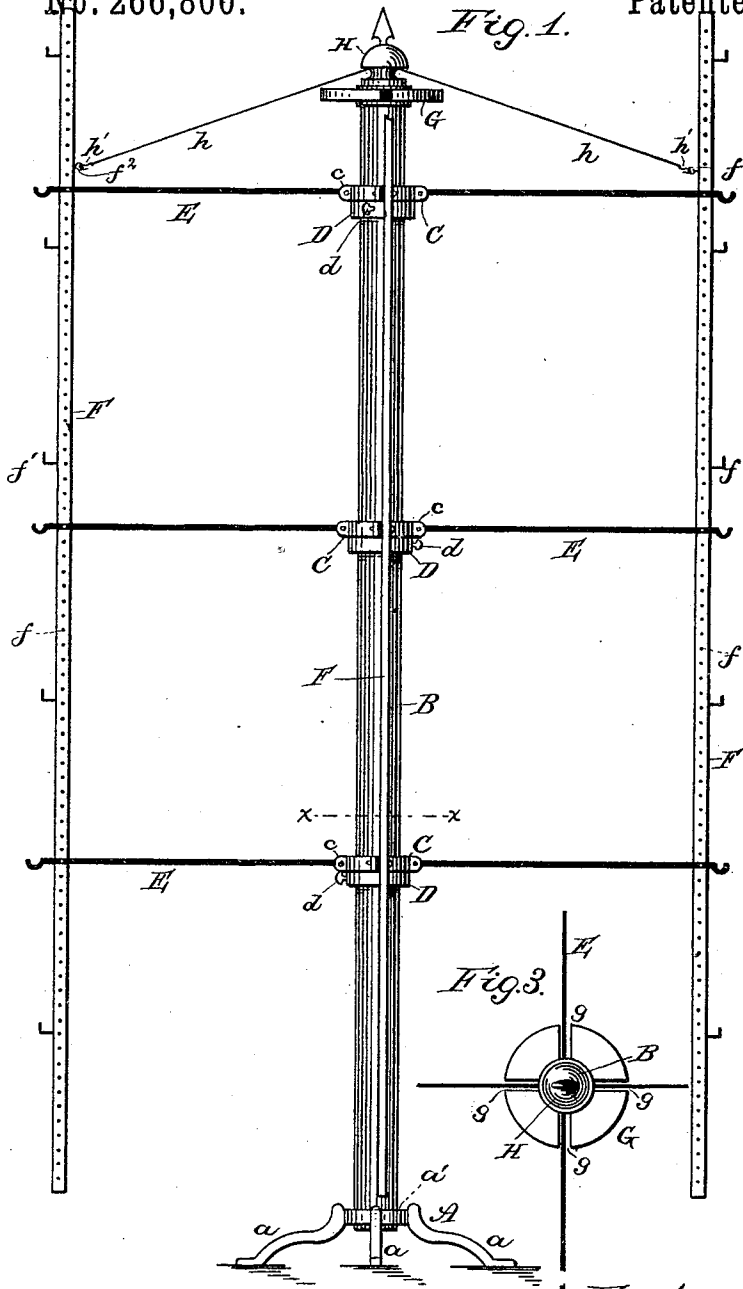

Witnesses:
Lucian Garner
W. S. D. Haines

Inventor:
William Fenner,
 per *J. W. Garner,*
 Attorney

UNITED STATES PATENT OFFICE.

WILLIAM FENNER, OF BATTLE CREEK, MICHIGAN.

CLOTHES-DRIER.

SPECIFICATION forming part of Letters Patent No. 266,800, dated October 31, 1882.

Application filed July 20, 1882. (No model.)

To all whom it may concern:

Be it known that I, WILLIAM FENNER, of Battle Creek, county of Calhoun and State of Michigan, have invented a new and useful
5 Improvement in Clothes-Driers; and I do hereby declare that the following is a full, clear, and exact description of the invention, which will enable others skilled in the art to which it appertains to make and use it, reference being had to the accompanying drawings, forming a part thereof.

My invention relates to an improvement in clothes-driers; and it consists in the peculiar construction and arrangement of parts, where-
15 by an exceedingly compact, cheap, simple, and serviceable machine is produced, as will be more fully set forth hereinafter.

In the accompanying drawings, which fully illustrate my invention, Figure 1 is a side elevation when open. Fig. 2 is a side elevation showing the reel folded. Fig. 3 is a top plan view. Fig. 4 is a cross-section on the line xx of Fig. 1.

A represents the base, of cast metal or other suitable construction, having the legs a , and provided with a socket, a' , from which rises the standard B. Encircling the standard is a series of hubs, C, which are adapted to revolve upon the standard, and are supported at suitable distances apart by means of the rings or flanges D, which are provided with set-screws d , so as to bind them firmly to the standard at any desired point, the hubs C thus resting and revolving upon the adjustable flanges, as
35 shown. The hubs C are provided on their peripheries with the lugs or ears e , in which are pivoted the inner ends of the radial arms E, their outer ends being pivoted to the vertical rods F. These rods F are provided with a series of perforations, f , by means of which the outer ends of the arms E may be pivoted to them at points to correspond to the adjustment of the center hubs, C, and are further provided on their outer edges with a series of
45 hooks, f' , upon which the clothes may be hung as well as upon the arms E. Secured near the top of the standard B is the circular flange G, which is provided with radial open slots g , corresponding in number to the vertical rods F, and adapted to receive them when the arms

E are folded up, as shown in Fig. 2. Surmounting the standard B is the ornamental cap H, swiveled thereto, to which are secured the cords h , which are provided with hooks h' , adapted to be secured to the screw-eyes f'' , secured near the upper ends of the rods F, the function of the cords h being to support the arms E in a horizontal position when the reel is opened.

The operation of my device will be readily understood from the foregoing description and by reference to the drawings.

A clothes-reel thus constructed will be found peculiarly efficient and convenient, admitting, as it does, of ready adjustment of the arms to suitable heights to accommodate different lengths of garments to be dried thereon, and, being adapted to be folded up when not in use, can be disposed of in any suitable out of the way place.

Having thus described my invention, I claim—

1. The combination of the base A, standard B, hubs C, secured thereto, flanges D, radial arms E, pivoted in rings, vertical rods F, connecting the outer ends of the radial arms E, flange G, having the open slots g for the reception of the rods F when folded up, and cap H, having cords h for supporting the radial arms E in a horizontal position, substantially
80 as shown and described.

2. The combination of the base A, standard B, hubs C, supported on the adjustable flange D, and having radial arms E pivoted thereto, flanges D, vertical rods F, provided with the perforations f , and adapted to connect the outer ends of the radial arms E, flange G, having the open radial slots g for the reception of the vertical rods F when folded up, and cap H, having cords h for supporting the radial arms
85 in a horizontal position, all combined and arranged to operate substantially in the manner and for the purpose set forth.

In testimony that I claim the foregoing I append my signature.

WILLIAM FENNER.

Witnesses:

THOMAS BARNES,
D. C. BABCOCK.