

- [54] CONTAINER
- [76] Inventor: **Stephen H. Longo, Jr.**, 17 Campbell Dr., Parlin, N.J. 08859
- [22] Filed: **Sept. 13, 1973**
- [21] Appl. No.: **396,897**
- [52] U.S. Cl. .... **229/27; 206/45.11; 229/22**
- [51] Int. Cl. .... **B65d 5/00; B65d 5/48**
- [58] Field of Search ..... **229/29 R, 29 C, 38, 39, 229/22, 27; 206/45.11**

[56] **References Cited**

UNITED STATES PATENTS

|           |         |                    |           |
|-----------|---------|--------------------|-----------|
| 3,397,771 | 8/1968  | Fogle .....        | 206/45.11 |
| 3,482,760 | 12/1969 | Pascus et al. .... | 229/22    |
| 3,550,834 | 12/1970 | McCall .....       | 229/22    |

Primary Examiner—Leonard D. Christian  
 Attorney, Agent, or Firm—Bain, Gilfillan & Rhodes

[57] **ABSTRACT**  
 A container formed of a unitary blank and providing at least one compartment of triangular cross-sectional configuration for receiving a product, including at least three panels of generally rectangular configura-

tion formed integrally from the unitary blank, the body panels being folded into a triangular configuration thereby providing the walls of the compartment; at least three end flaps formed from the unitary blank, each of the flaps being generally V-shaped and of a composite triangular configuration including a base triangular portion and an outwardly extending triangular portion formed integrally along one of the legs of the triangular base portion, the end flaps being folded at generally 90° with respect to said body panels and being interleaved such that the outwardly extending triangular portion of each flap resides behind the base triangular portion of another flap and being interleaved such that the end flaps form a triangle having a mid-point defined by the intersection of lines drawn from each vertex of the triangle to the opposite side of the triangle the interleaved end flaps providing one end of the compartment; and a plurality of additional end flaps formed from the unitary blank with each end flap being of a predetermined configuration, the additional end flaps being folded at generally 90° with respect to the body panels and being interleaved in a predetermined manner and providing the other end of the compartment.

13 Claims, 19 Drawing Figures

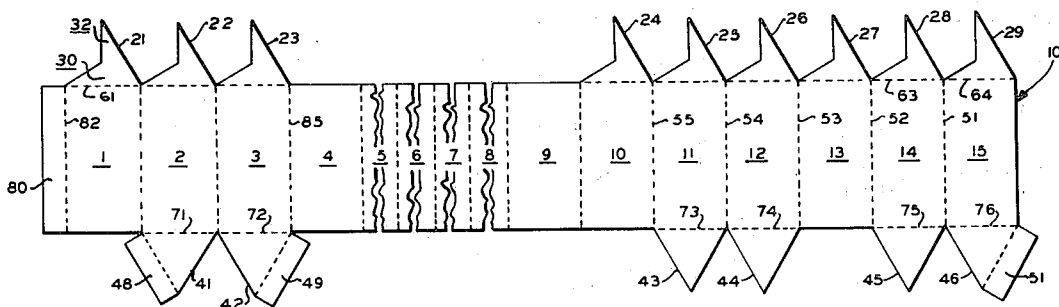

FIG. 1(a)

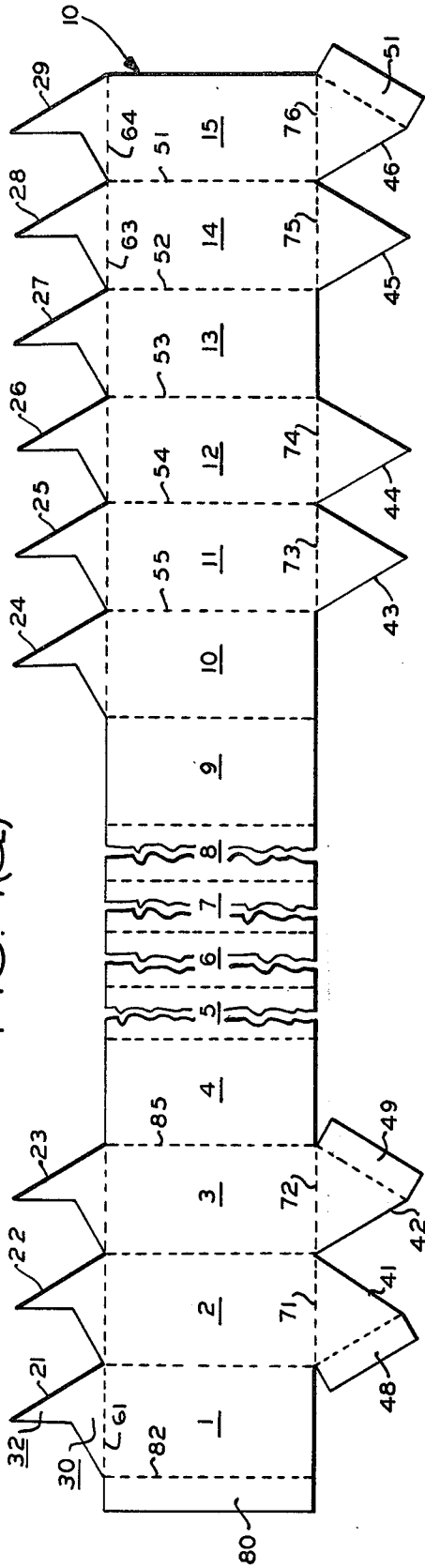

FIG. 1(d)

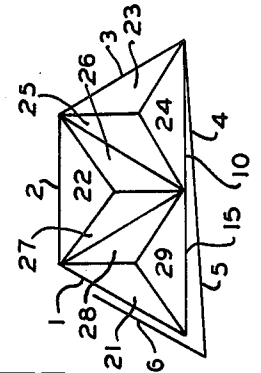

FIG. 1(b)

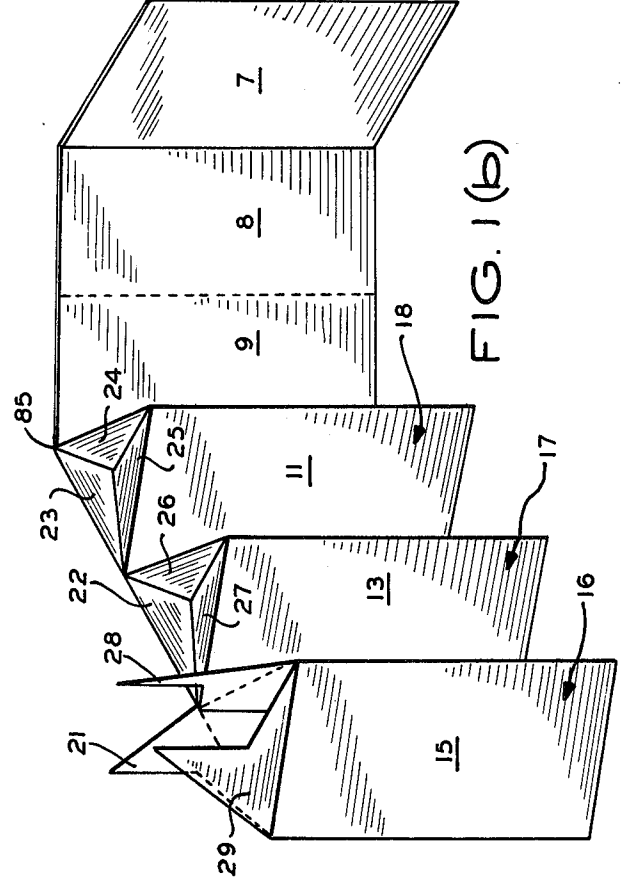
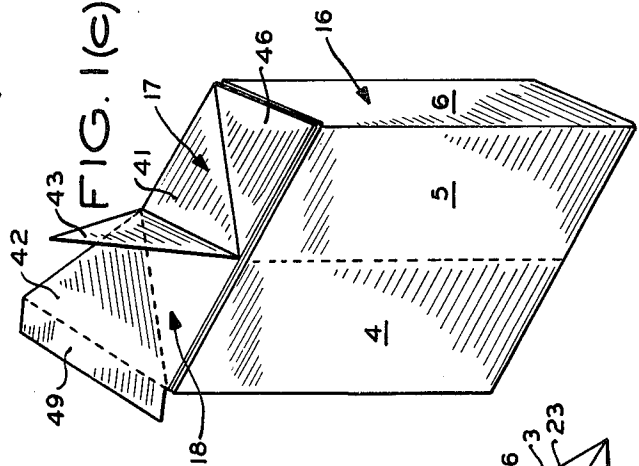

FIG. 1(c)



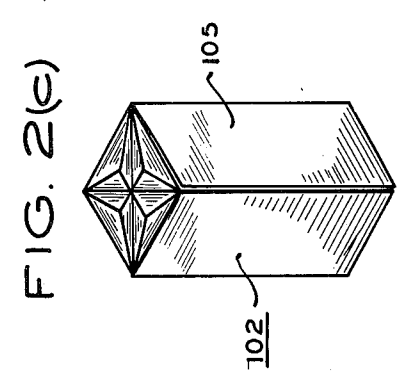
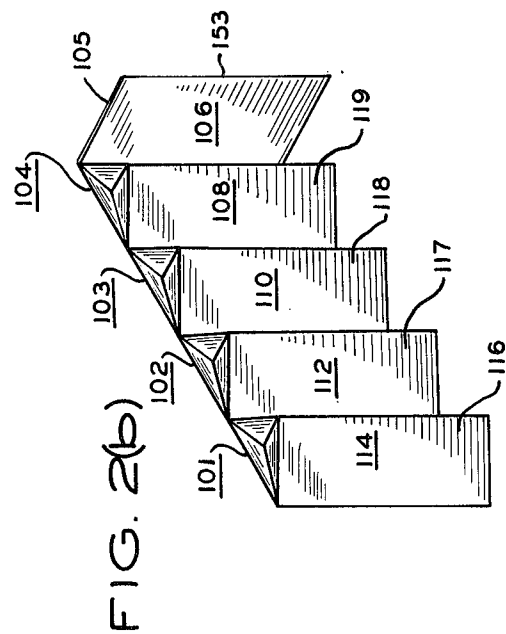
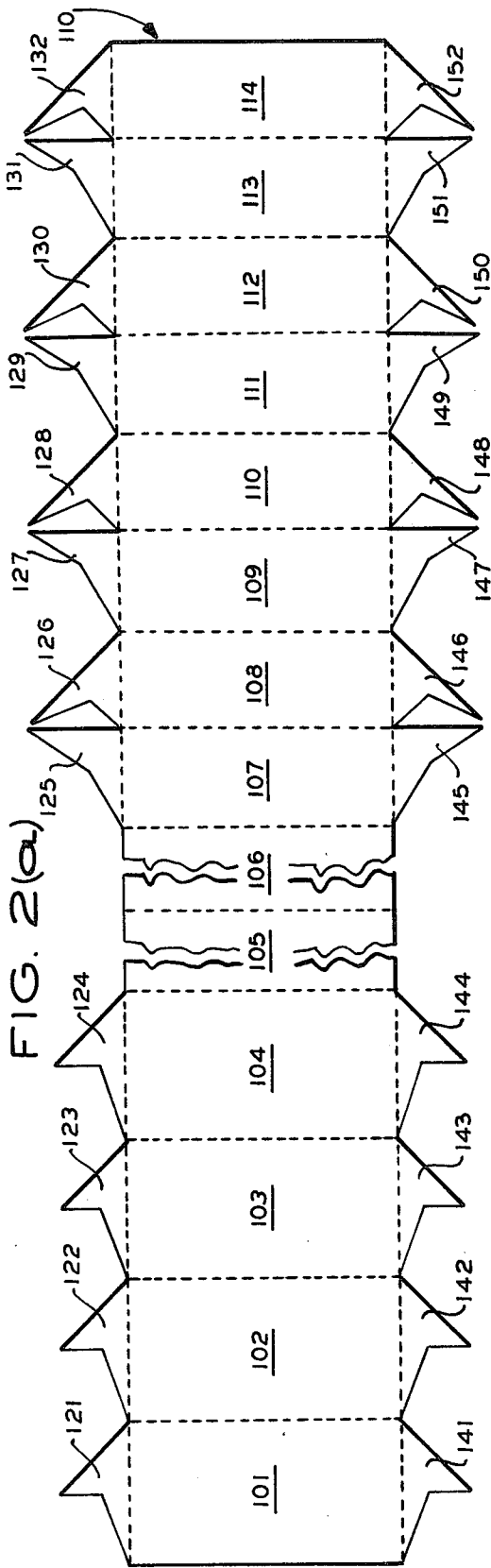

FIG. 3(a)

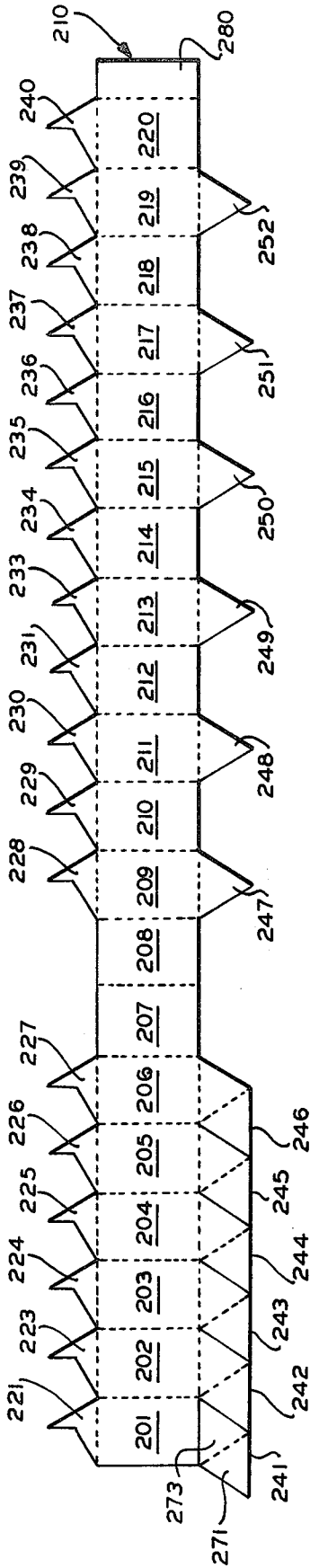

FIG. 3(c)

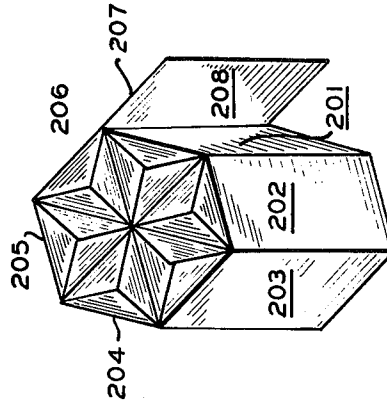

FIG. 3(d)

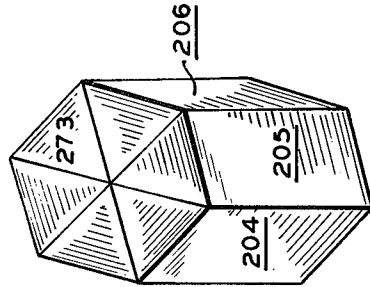

FIG. 3(b)

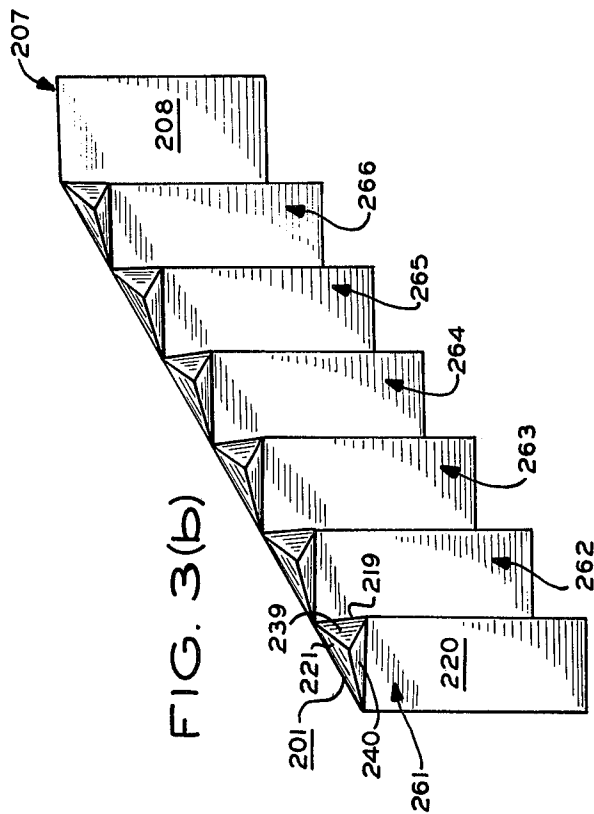

FIG. 4(a)

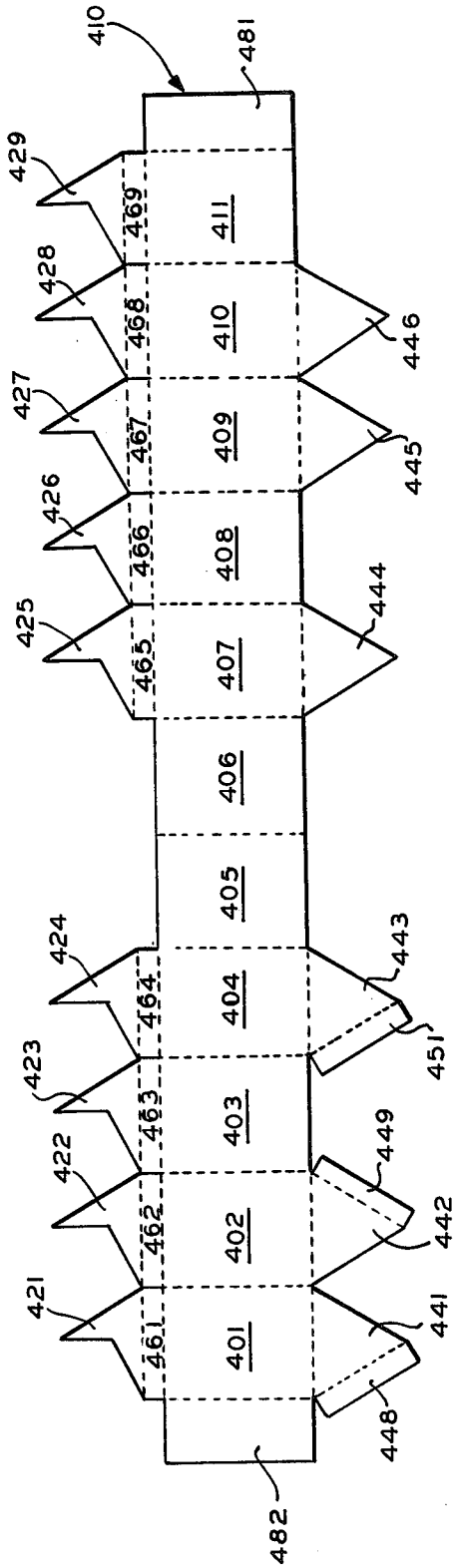

FIG. 4(d)

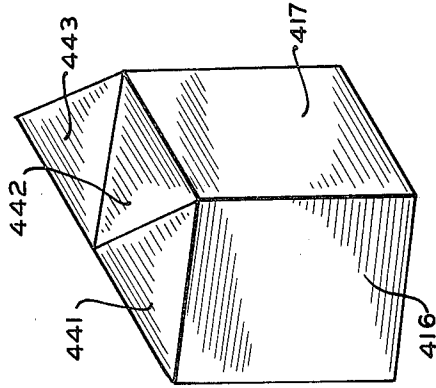

FIG. 4(c)

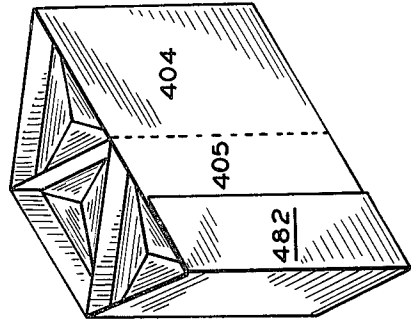

FIG. 4(b)

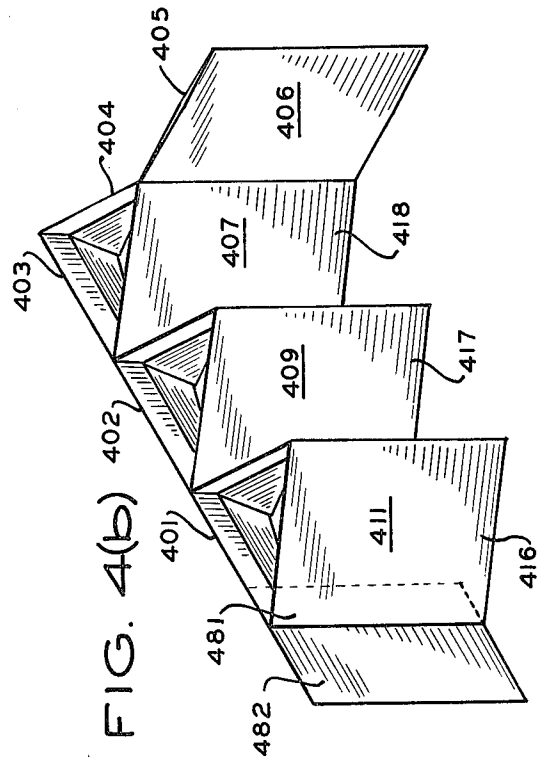

FIG. 5(a)

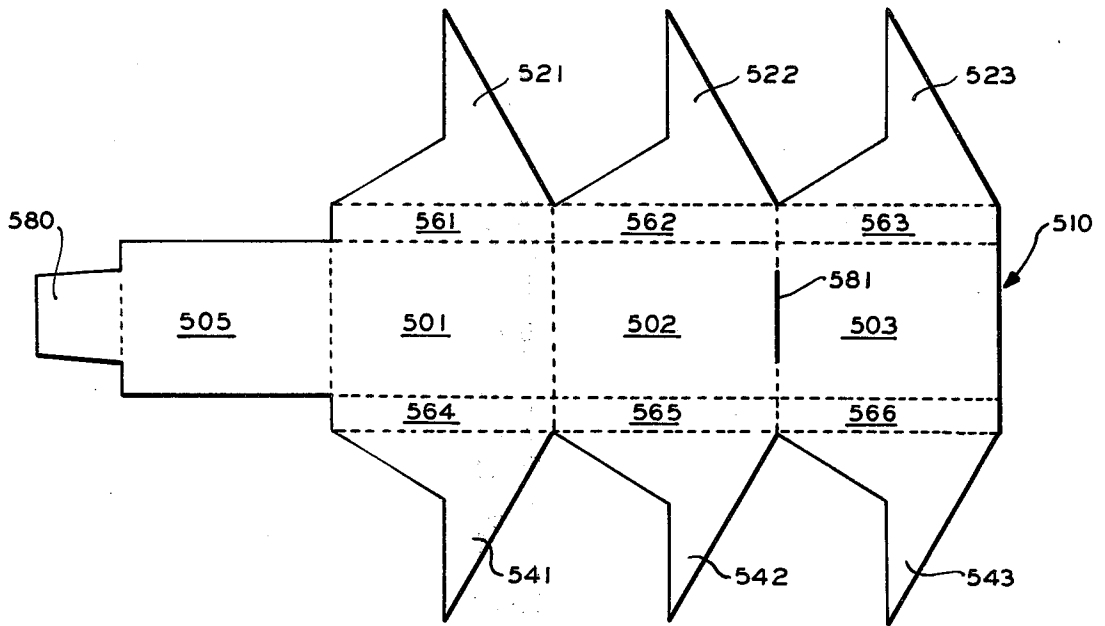

FIG. 5(b)

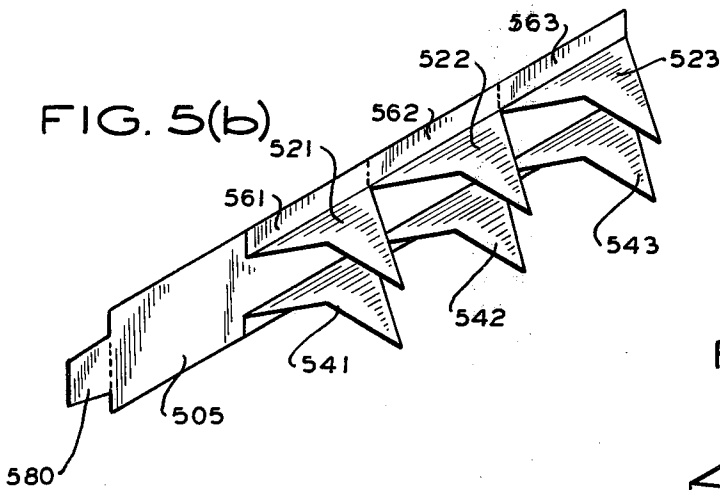

FIG. 5(c)

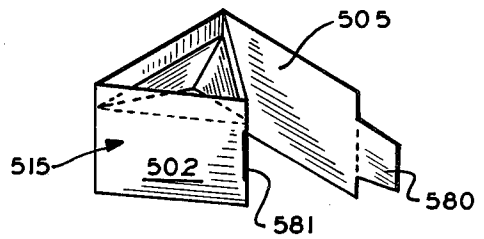
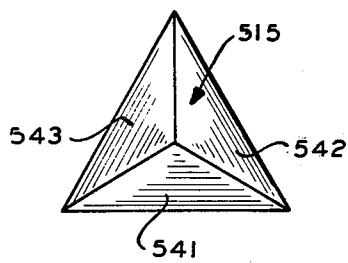

FIG. 5(d)



# 1

## CONTAINER

### BACKGROUND OF THE INVENTION

This invention relates in general to containers and in particular to a container formed from a unitary blank and for providing at least one compartment of generally triangular cross-sectional configuration for receiving product.

As known to those skilled in the art, the prior art is replete with many containers of various configurations for receiving product. Such containers are typically formed from a plurality of blanks and the manner in which such prior art containers are formed is cumbersome, tiresome and difficult to accomplish for the operator forming the container.

Accordingly, there exists a need in the art for containers which may be formed from a unitary blank and which may be formed by an operator in a manner that is simple and easy to perform.

### SUMMARY

In accordance with the present invention, a container providing at least one compartment of triangular cross-sectional configuration for receiving a product is formed from a unitary blank and such compartment may be comprised of at least three body panels of generally rectangular configuration formed from the blank wherein the body panels are folded into a triangular configuration thereby providing the walls of the compartment. In addition, the compartment may be comprised of at least three end flaps formed from the unitary blank wherein the end flaps are generally V-shaped and of a composite triangular configuration including a base triangular portion and an outwardly extending triangular portion formed integrally along one of the legs of the triangular base portion. The end flaps are interleaved so as to close and thereby provide one end of the compartment. Still further, a plurality of additional end flaps also formed from the unitary blank may be provided and suitably interleaved to close and provide the other end of the compartment.

### DESCRIPTION OF THE DRAWINGS

FIGS. 1a, b, c and d illustrate one embodiment of the present invention providing three triangular compartments;

FIGS. 2a, b and c illustrate another embodiment of the present invention providing four triangular compartments;

FIGS. 3a, b, c and d, illustrate a further embodiment of the present invention providing six triangular compartments;

FIGS. 4a, b, c and d illustrate a further embodiment of the present invention providing three triangular compartments wherein at least one end of each triangular compartment is recessed; and

FIGS. 5a, b, c and d illustrate a further embodiment of the present invention providing one triangular compartment wherein each end of the triangular compartment is recessed.

### DETAILED DESCRIPTION OF THE INVENTION

Referring now to FIG. 1, there is shown a container according to the present invention formed of a unitary blank indicated by general numerical designation 10 and which blank, when folded in accordance with the description set forth below, provides at least three com-

2

partments 16, 17 and 18, as shown in FIG. 1b, for receiving product. Each of the compartments is of a triangular cross-sectional configuration.

Referring now in particular to FIG. 1a, it will be noted that the unitary blank 10 is formed into a plurality of body panels numbered 1 through 15, which body panels are of generally rectangular configuration, and wherein the unitary blank 10 is further formed into a plurality of end flaps 21 through 29, and as taught with specific regard to end flap 21, includes a base triangular portion 30 and an outwardly extending triangular portion 32 formed integrally along one of the legs of the triangular base portion 30. In addition, the unitary blank 10 is formed into a plurality of additional end flaps 41 through 46. In the embodiment of the invention shown in FIG. 1a, it will be noted that the additional end flaps 41 through 46 are of generally triangular configuration, and that end flaps 41, 42 and 46 are provided with integrally formed tuck tabs 48, 49 and 51, respectively.

Generally, it will be understood by those skilled in the art, that the walls of compartment 16 are comprised of body panels 1, 14 and 15, the walls of compartment 17 are comprised of body panels 2, 12 and 13, and that the walls of compartment 18 are comprised of body panels 3, 10 and 11. Further, as may be best seen in FIG. 1b, one end of compartment 16 is comprised of interleaved generally V-shaped, composite triangular end flaps 21, 28 and 29; one end of compartment 17 is comprised of interleaved generally V-shaped, composite triangular end flaps 22, 26 and 27; and one end of compartment 18 is comprised of interleaved generally V-shaped, composite triangular end flaps 23, 24 and 25. The other end of compartment 18, as may be best seen in FIG. 1c, is comprised of interleaved additional end flaps 42 and 43; the other end of compartment 17 is comprised of interleaved additional end flaps 41 and 44; and the other end of compartment 16 is comprised of interleaved additional end flaps 45 and 46.

More specifically, and referring again to FIG. 1a, to form the unitary blank shown in FIG. 1a into the final container shown in FIGS. 1c and 1d, the rightward end of unitary blank 10, with reference to FIG. 1a, is folded generally toward the leftward end of the unitary blank such that body panels 7, 8 and 9 are folded over and in opposed overlying relationship with body panels 6, 5 and 4, respectively. Body panels 14 and 15 generally overlie body panel 1, body panels 12 and 13 generally overlie body panel 2, and body panels 10 and 11 generally overlie body panel 3. Body panel 15 is folded toward body panel 14 along the dashed line 51 in the counterclockwise direction such that the body panels 14 and 15 make an angle of 60° with respect to each other; body panel 14 is folded in the clockwise direction toward body panel 13 along the dashed line 52 in the clockwise direction such that body panels 13 and 14 form an angle of 60° with respect to each other; body panel 13 is folded in the counterclockwise direction toward body panel 12, along the dashed line 53 such that body panels 12 and 13 form an angle of 60° with respect to each other; body panel 12 is folded in the clockwise direction toward body panel 11 along the dashed line 54 in the clockwise direction such that body panels 11 and 12 form an angle of 60° with respect to each other; body panel 11 is folded in the counterclockwise direction toward body panel 10 in the counterclockwise direction such that body panels

10 and 11 form an angle of 60° with respect to each other. Generally V-shaped, composite triangular end flaps 21 is folded toward body panel 1 along the dashed line 61 such that the end flap and body panel are folded at an angle of 90° with respect to each other; and end flaps 28 and 29 are folded toward body panels 14 and 15 along the lines 63 and 64, respectively, such that the end flaps are folded with respect to the body panels at an angle of 90°. Similarly, the remaining end flaps are folded toward their respective body panels at angles of 90°. As may be best seen in FIGS. 1b and 1d, end flaps 21, 28 and 29 are interleaved with respect to each other such that the outwardly extending triangular portions of each end flap resides behind the base triangular portion of another end flap and are interleaved such that the end flaps form a triangle having a mid-point defined by the intersection of lines drawn from each vertex of the triangle to the opposite side of the triangle. Similarly, additional end flaps 41 through 46 are folded toward their respective body panels along dashed lines 71 through 76 such that the additional end flaps are at 90° with respect to their associated body panels. End flap 42 overlies end flap 43 and the tuck tab 49 is inserted between end flap 43 and body panel 10; end flap 41 overlies end flap 44 and the tuck tab 48 is inserted between end flap 44 and body panel 13; and end flap 46 overlies end flap 45 and tuck tab 51 is inserted between end flap 45 and body panel 1.

Fold tab 80 is folded toward body panel 1 along the dashed line 82 such that fold tab 80 forms an angle of 60° with respect to body panel 1 and fold tab 80 is inserted between body panel 15 and body panel 1. It will be understood by those skilled in the art that fold tab 80 may be of the size shown in FIG. 1a, or if it is desired to more securely insert fold tab 80 between body panels 15 and 1, fold tab 80 may be made larger and up to a size approximately equal to but desirably slightly smaller than the size of the body panels. Further, it will be understood by those skilled in the art that fold tab 80 may be secured to body panel 15 by other means, such as for example by being glued thereto by a suitable adhesive.

Referring again primarily to FIGS. 1b and 1d, the triangular compartments 16, 17 and 18 may be folded toward each other such that the combined end view thereof, as shown particularly in FIG. 1d, is generally trapezoidal. Further, it will be understood that body panels 7, 8 and 9, overlying body panels 6, 5 and 4, respectively, and as best shown in FIG. 1b, may be folded toward the compartments 16, 17 and 18 along the dashed line 85 (FIG. 1a) such that body panels 9 and 8 overlie body panels 10 and 15 respectively, and such that body panel 7 overlies body panel 1. It will be further understood by those skilled in the art that body panels 7, 8, and 9, overlying respectively, body panels 6, 5 and 4, and when folded in overlying relationship with body panels 10, 15 and 1, as described above, may be secured partially around the compartments 16 and 18 and secured therearound by a suitable adhesive.

Referring now to FIGS. 2a, 2b and 2c, there is shown another container according to the present invention formed of a unitary blank indicated by general numerical designation 110 and which blank, when folded substantially the same as with regard to the embodiment of FIG. 1, provides four compartments 116, 117, 118, and 119, as shown in FIG. 2b, for receiving product. Each of the compartments, as with regard to the embodiment

of FIG. 1, is of a triangular cross-sectional configuration.

As may be best seen in FIG. 2a, the embodiment of FIG. 2 is substantially the same as that of FIG. 1 except that the end flaps 121-132 and end flaps 141-152, formed respectively on either end of the body panels 101-114, are generally V-shaped and of a composite triangular configuration including a base triangular portion and an outwardly extending triangular portion formed integrally along one of the legs of the triangular base portion.

The container of FIG. 2 is formed by folding the unitary blank 110 substantially the same as taught above with regard to the embodiment of FIG. 1 and the end flaps are interleaved in the same manner as set forth above with regard to end flaps 21-29 of the embodiment of FIG. 1.

Further, the embodiment of FIG. 2 is provided with a plurality of additional body panels 105 and 106 formed from the unitary blank 110 and provide in combination a closure flap 153 for being folded around at least one of the compartments and for being secured to the compartment, such as for example by an adhesive to firmly retain the compartments in the complementary arrangement shown in FIG. 2c such that the end view thereof is generally rectangular.

With further specific regard to one of the compartments of the container of FIG. 2, and with specific regard to compartment 116, it will be noted that the compartment is comprised of three body panels 101, 113 and 114; three interleaved end flaps 121, 131 and 132; and three interleaved end flaps 141, 151 and 152.

Referring now to FIG. 3, there is shown a container according to the present invention formed from a unitary blank 210 and providing six compartments 261, 262, 263, 264, 265 and 266 as may be best seen in FIG. 3b. The six triangular compartments may be arranged complementarily, as shown in FIGS. 3c and 3d, such that the combined end view thereof is generally hexagonal.

Referring in particular to FIG. 3a, the unitary blank 10 may be formed into a plurality of body panels 201-220; a plurality of end flaps 221-240 of generally V-shaped and of composite triangular configuration; and a plurality of end flaps 241-252.

The container of FIG. 3 is formed substantially the same as set forth in detail above with regard to the embodiment of FIG. 1 and the generally V-shaped end flaps 221-240 are interleaved as set forth above with regard to the end flaps 21-29 of the embodiment of FIG. 1.

With regard to the end flaps 241-252, such end flaps are also interleaved to form one end of the compartments 261-266, with the end flaps 247-252 being folded at an angle of 90° with respect to their associated body panels, and the end flaps 241-246, each being of trapezoidal configuration including two triangular portions 271 and 273, as shown with regard to end flap 241, are folded at an angle of 90° with respect to their associated body panels and the triangular portion 271, with specific regard to end flap 241, is folded at an angle of 90° toward and with respect to triangular portion 273. End flaps 241 and 252 are interleaved to provide one end of the triangular compartment 261 and are interleaved such that end flap 252 resides behind triangular portion 273 of end flap 241 and the triangular portion 271 of end flap 241 is inserted between

body panel 219 and 220 which body panels form in combination with body panel 201, the three walls of triangular compartment 261. Similarly, the other end flaps 242-246 and end flaps 247 and 251 are interleaved to provide one end of triangular compartments 262-266.

With particular regard to triangular compartment 261, it will be understood that the three walls of triangular compartment 261 are provided by body panels 201, 219 and 220 and that one end of compartment 261 is provided by interleaved generally V-shaped end flaps 221, 239 and 240, and that the other end of triangular compartment 261 is provided by interleaved end flaps 241 and 252.

Referring now to FIG. 3*b*, triangular compartments 261 and 262 are formed as taught above and triangular compartments 263-266 are formed as taught above and, as so formed, are separated by body panels 207 and 208 which, upon being folded either inwardly or outwardly with regard to FIG. 3*b*, the triangular compartments 261-266 may be arranged complementarily as shown in FIGS. 3*c* and 3*d* such that the combined end view thereof is generally hexagonal.

Referring now to FIG. 4, there is shown an additional container according to the present invention which is substantially the same as with regard to the embodiment of FIG. 1, but wherein one end of the triangular compartments are recessed as shown in FIGS. 4*b* and 4*c*.

With particular regard to the container of FIG. 4, the unitary blank 410 is formed into a plurality of body panels 401-411, a plurality of end flaps 421-429 of generally V-shaped and composite triangular configuration; and a plurality of end flaps 441-446. In addition, the unitary blank 410 is provided with a plurality of generally rectangular fold panels 461-469, with each of the generally rectangular fold panels being formed between one end of the body panels and the base of the triangular portion of one of the generally V-shaped end flaps. The generally rectangular fold panels 461-469 are folded generally 180° inwardly with respect to and over their respectively associated body panels and parallel therewith and thereby positioning the generally V-shaped end flaps 421 and 429, when folded and interleaved as taught above with regard to the generally V-shaped end flaps 21-29 of FIG. 1, thereby recessing the respective compartment ends provided by the interleaved generally V-shaped end flaps 421-429 as noted above and as shown in specific detail in FIGS. 4*b* and 4*c*.

As with regard to the embodiment of FIG. 1, the fold tabs 482 and 481 may be folded over and suitably secured to such as by an adhesive to the body panel 406 and 401 respectively as shown in FIG. 4*b* thereby securing the triangular compartments 416, 417 and 418 complementarily such that their end view is trapezoidal as shown in FIGS. 4*c* and 4*d*.

With specific regard to compartment 416, the walls of the compartment are provided by body panels 401, 410 and 411, and one end of compartment 416 is provided by interleaved V-shaped end flaps 421, 428 and 429, and the other end of triangular compartment 416 is provided by interleaved end panels 441 and 446.

Referring now to FIG. 4*b*, upon the triangular compartments 416, 417 and 418 being formed upon the unitary blank 410 being folded as taught above, the triangular compartments are folded complementarily as

referred to above and the body panels 405 and 406, being folded against each other as shown in the FIGS., are folded over and reside against body panel 411 of triangular compartment 416.

Referring now to FIG. 5, there is shown a further container according to the present invention including one triangular compartment 515 formed from a unitary blank 510. The unitary blank 510 is formed into body panels 501, 502 and 503, end flaps 521-523 and end flaps 541-543 of generally V-shaped and composite triangular configuration, and a closure flap 505 and a tuck tab 580. In addition, the unitary blank 510 has a slot 581 formed therein between body panels 502 and 503 for receiving the tuck tab 580.

As shown in FIG. 5*b*, the fold panels 561-563 and 564-566 are folded generally 180° inwardly with respect to and over their associated body panels and parallel therewith. Then the body panels 501 and 502 are folded toward body panel 503 such that the body panels are formed into a triangle and then the end flaps 521 and 523 are interleaved as taught above with regard to the end flaps 21-29 of FIG. 1, and the end flaps 541-543 are similarly interleaved. Subsequently, the closure flap 505 is folded around or inside body panel 503 and the tuck tab 580 is folded toward the closure flap 505 and inserted into the slot 581, or is inserted along the underside of body panel 503 with the tuck tab extending through the slot 581, thereby firmly forming the unitary blank 510 into the triangular compartment 515 having recessed ends.

Referring now generally to the containers of the present invention described in detail above, it will be understood that with regard to each of the embodiments of the containers shown in the respective FIGS. that either or both ends of the respective compartments could be recessed, that the end flaps could either be of the generally V-shaped and composite triangular configuration or of the configuration of the end flaps 241-252 of FIG. 3*a* or the end flaps 41-46 of FIG. 1*a*. In addition, the respective containers could either be closed by fold tabs secured to body panels by an adhesive or could be closed by a tuck tab suitably received in a slot formed in the unitary blank. It will be further understood that the choice of end flap construction will be determined by desired ease of accessibility to the interior of the various compartments.

It will be further understood by those skilled in the art that the unitary blank of the present invention may be of a suitable paper, clear acetate or other suitable foldable material.

In addition, the structure of the present invention may also be utilized as a shock absorber wherein each compartment would provide an air pocket.

It will be further understood by those skilled in the art that many modifications may be made in the present invention without departing from the spirit and scope thereof.

What is claimed is:

1. A container formed of a unitary blank and providing at least one compartment of triangular cross-sectional configuration for receiving a product, comprising:

at least three body panels of generally rectangular configuration formed from said unitary blank, said body panels being folded into a triangular configuration thereby providing the walls of said compartment;

at least three end flaps formed from said unitary blank, each of said flaps provided with at least a portion which is generally V-shaped and of a composite triangular configuration including a base triangular portion and an outwardly extending triangular portion formed integrally along one of the legs of said triangular base portion, said end flaps being folded in a predetermined manner with respect to said body panels and being interleaved such that said outwardly extending triangular portion of each flap resides behind the base triangular portion of another flap and being interleaved such that said end flaps form a triangle having a mid-point defined by the intersection of lines drawn from each vertex of the triangle to the opposite side of the triangle, said interleaved end flaps providing one end of said compartment; and

a plurality of additional end flaps formed from said unitary blank with each end flap being of predetermined configuration, said additional end flaps being folded in a predetermined manner with respect to said body panels and being interleaved in a predetermined manner providing the other end of said compartment.

2. A container according to claim 1 wherein said compartment end provided by said three generally V-shaped end flaps is recessed, further comprising:

at least three generally rectangular fold panels formed from said unitary blank with each of said fold panels formed between one end of one of said body panels and the base of said triangular portion of one of said generally V-shaped end flaps, said fold panels being folded generally 180° inwardly with respect to and over said body panels and parallel therewith and thereby positioning said folded and interleaved generally V-shaped end flaps inwardly of the ends of said body panels thereby recessing said compartment end provided by said interleaved generally V-shaped end flaps.

3. A container according to claim 1 wherein said plurality of additional end flaps are of the same number and configuration as said three generally V-shaped end flaps and are folded and interleaved in the same manner.

4. A container according to claim 3 wherein said compartment end provided by said plurality of additional end flaps is also recessed, further comprising:

at least three additional generally rectangular fold panels formed from said unitary blank with each of said additional fold panels being formed between the other end of one of said body panels and the base of said triangular portion of one of said generally V-shaped end flaps, said additional fold panels being folded generally 180° inwardly with respect to and over said body panels and parallel therewith thereby positioning said folded and interleaved generally V-shaped end flaps inwardly of the ends of said body panels thereby recessing said other compartment end provided by said plurality of additional interleaved end flaps.

5. A container according to claim 4 further comprising:

a closure flap of predetermined configuration formed from said blank and formed integrally with and provided at the outer side of one of said body panels, said closure flap having an outer side;

a tuck tab of generally trapezoidal configuration formed from said blank and formed integrally with and provided at said outer side of said closure flap; a slot formed in said blank between two of said body panels, said slot for receiving said tuck tab;

upon said closure flap being folded around at least one of said body panels and upon said tuck tab being received within said slot, said compartment being firmly closed; and

upon said tuck tab being removed from said slot, upon said closure flap being unfolded from around said at least one body panel, upon said body panels being at least partially unfolded away from each other, and upon said interleaved end flaps being at least partially removed from said interleaved relationship, said compartment being made accessible for the receipt and removal of said product.

6. A container formed of a unitary blank and providing at least three compartments for receiving product, each of said compartments being of triangular cross-sectional configuration, wherein:

a. each one of said three compartments is comprised of:

i. at least three body panels of generally rectangular configuration formed from said unitary blank, said body panels being folded with respect to each other into a triangular configuration thereby providing the walls of said compartment;

ii. at least three end flaps formed from said unitary blank, each of said flaps being generally V-shaped and of a composite triangular configuration including a base triangular portion and an outwardly extending triangular portion formed integrally along one of the legs of said triangular base portion, said end flaps being folded at generally 90° with respect to said body panels and being interleaved such that said outwardly extending triangular portion of each flap resides behind the triangular portion of another flap and being interleaved such that said end flaps form a triangle having a midpoint defined by the intersection of lines drawn from each vertex of the triangle to the opposite side of the triangle, said interleaved end flaps providing one end of said compartment; and

iii. a plurality of additional end flaps formed from said unitary blank with each end flap being of a predetermined configuration, said additional end flaps being folded at generally 90° with respect to said body panels and being interleaved in a predetermined manner and providing the other end of said compartment; and

b. said three triangular compartments being arranged complementarily such that the combined end view thereof is generally trapezoidal.

7. A container according to claim 6 further comprising:

an additional plurality of body panels formed from said unitary blank and providing in combination a closure flap for being folded around at least two of said triangular compartments and for being secured thereto as by an adhesive to firmly retain said compartments complementarily with said generally trapezoidal end view; and

upon said additional end flaps of each compartment being removed from said interleaved relationship,

said each compartment being made accessible for the receipt and removal of said product.

8. A container according to claim 7 wherein said end of each of said triangular compartments provided by said generally V-shaped end flaps is recessed, further comprising:

at least nine generally rectangular fold panels formed from said unitary blank with each of said fold panels formed between one end of one of said body panels and the base of said triangular portion of one of said generally V-shaped end flaps, said fold panels being folded generally 180° inwardly with respect to and over said body panels and parallel therewith and thereby positioning said folded and interleaved generally V-shaped end flaps inwardly of the ends of said body panels thereby recessing said compartment end provided by said interleaved generally V-shaped end flaps.

9. A container according to claim 8 wherein said plurality of additional end flaps are of the same number and configuration as said three generally V-shaped end flaps and are folded and interleaved in the same manner.

10. A container formed from a unitary blank and providing at least four compartments for receiving product, each of said compartments being of triangular cross-sectional configuration, wherein:

- a. each of said four compartments is comprised of:
  - i. at least three body panels of generally rectangular configuration formed from said unitary blank, said body panels being folded with respect to each other into a triangular configuration thereby providing the walls of said compartment;
  - ii. at least three end flaps formed from said unitary blank, each of said flaps being generally V-shaped and of a composite triangular configuration including a base triangular portion and an outwardly extending triangular portion formed integrally along one of the legs of said triangular base portion, said end flaps being folded at generally 90° with respect to said body panels and being interleaved such that said outwardly extending triangular portion of each flap resides behind the base triangular portion of another flap and being interleaved such that said end flaps form a triangle having a mid-point defined by the intersection of lines drawn from each vertex of the triangle to the opposite side of the triangle, said interleaved end flaps providing one end of said compartment; and
  - iii. a plurality of additional end flaps formed from said unitary blank with each end flap being of a predetermined configuration, said additional end flaps being folded at generally 90° with respect to said body panels and being interleaved in a predetermined manner and providing the other end

- of said compartment; and
- b. said four triangular compartments being arranged complementarily such that the combined end view thereof is generally rectangular.

11. A container according to claim 10 further comprising:

an additional plurality of body panels formed from said unitary blank and providing in combination a closure flap for being folded around at least one of said compartments and for being secured thereto by an adhesive to firmly retain said compartments complementarily with said generally rectangular end view.

12. A container according to claim 10 wherein said plurality of additional end flaps are of the same number and configuration as said three generally V-shaped end flaps and are folded and interleaved in the same manner.

13. A container formed from a unitary blank and providing at least six compartments for receiving product, each of said compartments being of triangular cross-sectional configuration, wherein:

- a. each of said four compartments is comprised of:
  - i. at least three body panels of generally rectangular configuration formed from said unitary blank, said body panels being folded with respect to each other into a triangular configuration thereby providing the walls of said compartment;
  - ii. at least three end flaps formed from said unitary blank, each of said flaps being generally V-shaped and of a composite triangular configuration including a base triangular portion and an outwardly extending triangular portion formed integrally along one of the legs of said triangular base portion, said end flaps being folded at generally 90° with respect to said body panels and being interleaved such that said outwardly extending triangular portion of each flap resides behind the base triangular portion of another flap and being interleaved such that said end flaps form a triangle having a mid-point defined by the intersection of lines drawn from each vertex of the triangle to the opposite side of the triangle, said interleaved end flaps providing one end of said compartment; and
  - iii. a plurality of additional end flaps formed from said unitary blank with each end flap being of a predetermined configuration, said additional end flaps being folded at generally 90° with respect to said body panels and being interleaved in a predetermined manner and providing the other end of said compartment; and
- b. said six triangular compartments being arranged complementarily such that the combined end view thereof is generally hexagonal.

\* \* \* \* \*