



- (51) **International Patent Classification:**
G09G 5/00 (2006.01) *H04N 7/00* (2011.01)
- (21) **International Application Number:**
PCT/US2011/036967
- (22) **International Filing Date:**
18 May 2011 (18.05.2011)
- (25) **Filing Language:** English
- (26) **Publication Language:** English
- (71) **Applicant (for all designated States except US):** MAGNA ELECTRONICS INC. [US/US]; 10410 North Holly Road, Holly, Michigan 48442 (US).
- (72) **Inventors; and**
- (75) **Inventors/Applicants (for US only):** GIBSON, Joel S. [US/US]; 16438 Locke Drive, Linden, Michigan 48451 (US). BYRNE, Steven V. [US/US]; 9408 Fair Oaks Drive, Goodrich, Michigan 48438 (US). SHRINER, Richard D. [US/US]; 6239 Cold Spring Trail, Grand Blanc, Michigan 48439 (US).
- (74) **Agents:** FLORY, Timothy, A. et al.; VAN DYKE, GARDNER, LINN & BURKHART, LLP, 2851 Charlevoix Dr., S.E., Suite 207, Grand Rapids, Michigan 49546 (US).
- (81) **Designated States (unless otherwise indicated, for every kind of national protection available):** AE, AG, AL, AM,

AO, AT, AU, AZ, BA, BB, BG, BH, BR, BW, BY, BZ, CA, CH, CL, CN, CO, CR, CU, CZ, DE, DK, DM, DO, DZ, EC, EE, EG, ES, FI, GB, GD, GE, GH, GM, GT, HN, HR, HU, ID, IL, IN, IS, JP, KE, KG, KM, KN, KP, KR, KZ, LA, LC, LK, LR, LS, LT, LU, LY, MA, MD, ME, MG, MK, MN, MW, MX, MY, MZ, NA, NG, NI, NO, NZ, OM, PE, PG, PH, PL, PT, RO, RS, RU, SC, SD, SE, SG, SK, SL, SM, ST, SV, SY, TH, TJ, TM, TN, TR, TT, TZ, UA, UG, US, UZ, VC, VN, ZA, ZM, ZW.

- (84) **Designated States (unless otherwise indicated, for every kind of regional protection available):** ARIPO (BW, GH, GM, KE, LR, LS, MW, MZ, NA, SD, SL, SZ, TZ, UG, ZM, ZW), Eurasian (AM, AZ, BY, KG, KZ, MD, RU, TJ, TM), European (AL, AT, BE, BG, CH, CY, CZ, DE, DK, EE, ES, FI, FR, GB, GR, HR, HU, IE, IS, IT, LT, LU, LV, MC, MK, MT, NL, NO, PL, PT, RO, RS, SE, SI, SK, SM, TR), OAPI (BF, BJ, CF, CG, CI, CM, GA, GN, GQ, GW, ML, MR, NE, SN, TD, TG).

Declarations under Rule 4.17:

- as to applicant's entitlement to apply for and be granted a patent (Rule 4.17(ii))
- of inventorship (Rule 4.17(iv))

Published:

- with international search report (Art. 21(3))

(54) **Title:** SELF-CALIBRATING VEHICULAR CAMERA

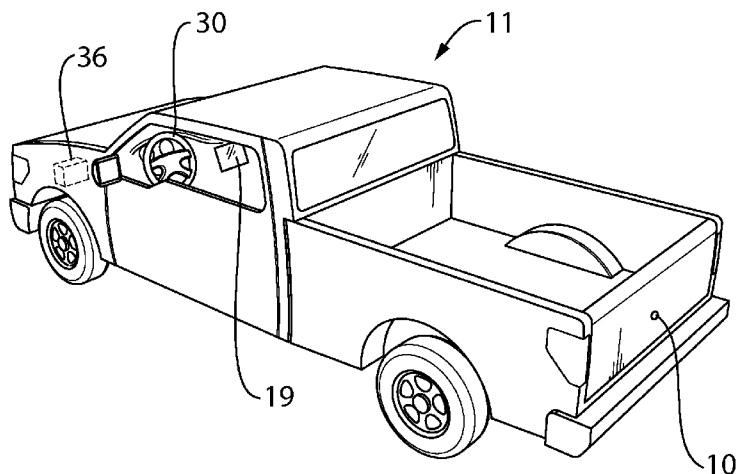

FIG. 1

(57) **Abstract:** A vehicular camera includes a housing, a lens, an image sensor positioned for receiving images from the lens, a processor, and a memory. The memory contains a plurality of overlays. The processor is programmed to (a) receive first input data from a vehicle in which the camera is to be mounted, wherein the first input data correspond to the configuration of the vehicle, and (b) select a particular overlay to display based at least in part on the input received.

WO 2012/158167 A1

SELF-CALIBRATING VEHICULAR CAMERA**FIELD OF THE INVENTION**

[0001] The present invention relates to vehicular cameras and more particularly to rearview vehicular cameras that display overlays onto the camera image.

BACKGROUND OF THE INVENTION

[0002] Vehicular cameras are used for a variety of purposes, such as to assist a driver in avoiding obstacles behind a vehicle when backing up. Some cameras add overlays onto the camera image to assist the driver in determining distances to obstacles behind the vehicle, vehicle trajectory and other useful information. The overlays may be static or may be dynamic. A dynamic overlay is an overlay that is changed by the camera based on certain inputs. For example, some cameras display a predicted vehicle trajectory based on certain factors such as steering wheel angle. The overlays, whether static or dynamic, will change depending on the angle of mounting of the camera, the height of the camera off the ground, distance from the camera horizontally to the rear axle of the vehicle, the steering gear ratio for the vehicle, and possibly other factors. As a result, cameras for different vehicles up until now have had different programming and thus have different part numbers associated with them. This results in a potentially large number of part numbers and inventory. A particular vehicle family, such as a particular truck, may have numerous vehicle configurations that will impact the overlays that are displayed by the rearview camera. Such configurations would include, for example, regular cab with short bed, regular cab with long bed, extended cab with short bed and extended cab with long bed.

[0003] It would be desirable to reduce the number of separate part numbers that are associated with variations on programming for essentially the same camera.

SUMMARY OF THE INVENTION

[0004] In one aspect, the invention is directed to a vehicular camera including a housing, a lens, an image sensor positioned for receiving images from the lens, a processor, and a memory. The memory contains a plurality of overlays. The processor is programmed to:

receive first input data from a vehicle in which the camera is to be mounted, wherein the first input data correspond to the configuration of the vehicle, and
select a particular overlay to display based at least in part on the input received.

BRIEF DESCRIPTION OF THE DRAWINGS

[0005] The present invention will now be described by way of example only with reference to the attached drawings in which:

[0006] Figure 1 is a perspective view of a vehicle with a vehicular camera in accordance with an embodiment of the present invention; and

[0007] Figure 2 is a cutaway side view of the vehicular camera shown in Figure 1;

[0008] Figure 3 is a schematic illustration of selected components from the camera shown in Figure 1;

[0009] Figure 4 is an illustration of selected overlays that are stored in a memory that is part of the camera shown in Figure 1;

[0010] Figure 5 is a lookup table that is used by the camera to determine which overlay to use on an image; and

[0011] Figure 6 is another lookup table that is used by an enhanced version of the camera to determine which overlay to use on an image.

DETAILED DESCRIPTION OF THE INVENTION

[0012] Reference is made to Figure 1, which shows an exploded view of a vehicular camera 10 for a vehicle 11, in accordance with an embodiment of the present invention. In the embodiment shown, the camera 10 is a rearview camera that is configured to assist a vehicle driver when backing the vehicle up. Referring to Figure 2, the vehicular camera 10 includes an image sensor 12 (eg. a CCD or a CMOS sensor), a housing 14, a lens 16, and an image processing board 18. The lens 16 transmits and focuses images from behind the vehicle 11 onto the image sensor 12. Referring to Figure 3, the image processing board 18 communicates with and receives images from the image sensor 12 and transmits the images to other vehicular devices, such as an in-cabin display 19. The images are shown at 20.

Referring to Figure 3, the image processing board 18 includes a memory 21 in which is stored a set of overlays 22 (Figure 4) and a processor 24 (Figure 3) which selects an overlay 22 (Figure 4) to add to the images 20 (Figure 3) prior to sending the images to the in-cabin display 19.

[0013] The overlays 22 (Figure 4) are dynamic overlays in the sense that the processor 24 selects different ones to apply to the image 20 depending on certain criteria. For example, in the example shown, the overlays 22 represent predicted vehicle trajectories based on certain data concerning the vehicle 11.

[0014] As shown in Figure 3, the camera 10 receives input data from the vehicle 11 via a bus 28 (eg. a LIN bus). The input data may include first input data which corresponds to the particular configuration of vehicle 11 the camera 10 is mounted to. For example, a particular vehicle family may include a range of vehicle configurations, covering vehicles with 4 different wheelbases. In this simplified example, other aspects of the vehicle configurations, such as the distance from the camera to the rear axle, are the same for each vehicle. The first input data would indicate to the camera 10 which of the 4 different vehicles the camera 10 is mounted to.

[0015] The input data may further include second input data which corresponds to the angle of the steering wheel in the vehicle 11. The steering wheel is shown at 30 in Figure 1.

[0016] The processor 24 uses the first and second input data to identify which overlay 22 to use on the images 20. The processor 24 may achieve this in any suitable way. One such way is by using the first and second input data as input parameters for a lookup table shown at 32 that is stored in the memory 21.

[0017] The lookup table 32 is shown in more detail in Figure 5. As can be seen, and by way of example only, the aforementioned 4 different vehicle configurations are represented at 11a, 11b, 11c and 11d. A set of steering wheel angles are shown at 34 for each of the vehicle configurations 11a-11d. As can be seen, for vehicle configuration 11a (which has a wheelbase of 100"), if the second input data indicated a steering wheel angle of 240 degrees, the processor 24 would add the overlay shown at 22-4 in Figure 4, to the image 20 (Figure 3) prior to transmitting the image 20 with the overlay 22-4 to the in-cabin display 19. As another

example, for vehicle configuration 11c (which has a wheelbase of 120"), if the second input data indicated a steering wheel angle of 460 degrees, the processor 24 would add the overlay shown at 22-7 in Figure 4, to the image 20 (Figure 3) prior to transmitting the image 20 with the overlay 22-7 to the in-cabin display 19.

[0018] It can be seen that the lookup table 32 does not require a substantial amount of the memory 21. Furthermore it can be seen that the total number of overlays 22 that needs to be stored in the memory 21 is no more than would need to be stored for the vehicle configuration 11a. It will be noted that for the 4 vehicle configurations shown in the lookup table 32, 13 of the overlays 22 (ie. overlays 22-1 to 22-13) are common to all of the vehicle configurations, a further one overlay (22-14) is common to 3 of them, a further 2 overlays (22-15 and 22-16) are common to 2 of them, and only 2 overlays (22-17 and 22-18) are unique to one of them. Accordingly, the amount of memory consumed by providing the capability of handling 4 different vehicle configurations is not substantially more than the amount of memory already provided on such image processing boards when handling a single vehicle configuration. Additionally, the use of a lookup table is not computationally stressful for the processor 24.

[0019] However, it is alternatively possible that instead of a lookup table to determine which overlay 22 to use, the processor 24 could use the steering wheel angle data and the vehicle configuration data to calculate the projected vehicle trajectory and to then select an overlay 22 that is suitable. As another alternative, it is possible for the overlays to be mathematically generated by the processor 24 based on the steering wheel angle data and the vehicle configuration data. In other words, the processor 24 could, using the steering wheel angle data and the vehicle configuration data, calculate the curve on which to draw an overlay 22 instead of grabbing a premade overlay 22 from memory. In such an embodiment, the processor 24 could calculate an entirely new overlay each time it samples the steering wheel angle input, or it could calculate an adjustment to make to the previously drawn overlay each time it samples the steering wheel angle input. In either case, the processor 24 would be capable of drawing a continuous range of overlays 22 as compared to embodiments wherein a premade overlay 22 is pulled from memory and used over a range of steering wheel angles. In such an embodiment, the vehicle configuration data can be used to modify the formulas used

by the processor 24 to determine the appropriate curve of the overlay 22. These modifications to the formulas (eg. values for certain constants in the formulas) may be stored in an array or a lookup table stored in memory 21, and which is accessed by the processor 24 based on the vehicle configuration data. The aforementioned lookup table described above is the preferred approach, however.

[0020] It will be noted that, in part, many of the overlays 22 are common to the different vehicle configurations because the vehicle configurations are part of the same vehicle family. As such, many of the parameters that would impact the appearance of the overlays would be the same for all members of the vehicle family. Such parameters would include for example, the lateral distance of the camera from the edge of the vehicle, the height of the camera from the ground and the angle of the camera relative to horizontal.

[0021] Reference is made to Figure 6, which shows a variant of the lookup table 32 that will be used to describe an enhancement to the embodiment shown in Figures 1-5. In some vehicle families it may be that the vehicle may be fitted with one of two different steering gear mechanisms each with its own gear ratio. The steering gear mechanism is shown in dashed outline at 36 in (Figure 1). The two alternative steering gear mechanisms that could be used in the vehicle are shown at 36a and 36b in Figure 6. As can be seen, the vehicle family shown in Figure 6 includes 5 different vehicle configurations (shown at 11a-11e in Figure 6), each with its own wheelbase. The first steering gear mechanism 36a can be used on 4 of the configurations. The second steering gear mechanism 36b can be used on 3 of the configurations.

[0022] In some cases the particular steering gear mechanism 36 used on the vehicle 11 may not be reflected in the vehicle configuration data (ie. the first input data) that is transmitted to the camera 10. It will be understood of course that without knowing which steering gear mechanism (more particularly, which gear ratio) is used, the camera 10 does not have enough information based solely on the vehicle configuration and the steering wheel angle to determine the projected vehicle trajectory. In the particular exemplary case shown in Figure 6, if the vehicle configuration data indicates that the vehicle is of type 11a or 11b, the processor 24 would have sufficient data because those configurations only use steering gear mechanism 36a. Similarly, if the vehicle configuration data indicates that the vehicle

is of type 11e, the processor 24 would have sufficient data because those configurations only use steering gear mechanism 36b. However, if the vehicle configuration data indicates that the vehicle is of type 11c or 11d, the processor 24 would not have sufficient data because either steering gear mechanism 36a or 36b could be used with those configurations.

[0023] In order to determine which of the two steering gear mechanisms 36a or 36b is used on the vehicle 11, the camera 10 is activated and notified when the steering wheel 30 (Figure 1) is turned to full lock. The second input data (ie. the steering wheel angle data) is transmitted to the camera 10, and the processor 24 compares it to the maximum steering wheel angle shown in the lookup table 32 (Figure 6) for that particular vehicle configuration. For example, for vehicle configuration 11c, if the steering wheel angle data (ie. the second input data) sent to the camera 10 indicates 680 degrees of rotation, then the processor 24 can determine that the first steering gear mechanism 36a is being used on the vehicle 11. Alternatively, if the steering wheel angle data (ie. the second input data) sent to the camera 10 indicates 590 degrees of rotation, then the processor 24 can determine that the first steering gear mechanism 36b is being used on the vehicle 11.

[0024] While the example overlays shown and described herein relate to the predicted vehicle trajectory, it will be understood that other overlays relating to other vehicle properties could be displayed. Additionally it will be understood that the overlays 22 shown and described may not be the only overlays shown on the images 20. Additionally dynamic and/or static overlays could also be shown on the images by the camera.

[0025] The processor 24 and memory 21 have been shown in Figure 3 to be on an image processing board 18. The image sensor 12 may be attached directly to the board 18. It is alternatively possible for the processor 24 to reside on a separate board (not shown), which is distinct from the board to which the image sensor 12 is attached. In another alternative it is possible for the processor 24 to comprise a processor that is integral with the image sensor 12 and one that is separate from the image sensor 12. In such an alternative, both processors are collectively referred to as processor 24. In yet another alternative, it is possible for the processor 24 to comprise an external processor that is outside the housing 14 of the camera 10 that

cooperates with one or more processors that are contained within the housing 14. In such an embodiment, such an external processor may be positioned anywhere within the vehicle.

[0026] Similarly, the memory 21 may alternatively reside on a board to which the image sensor 12 is integrally attached, or on a board that is separate from the board to which the image sensor 12 is attached. Alternatively the memory 21 may reside in part on the board to which the image sensor 12 is attached and in part on a board that is separate from the board to which the image sensor 12 is attached, in which case the two portions of the memory would collectively be referred to as the memory 21. In yet another alternative, it is possible for the memory 21 to comprise an external processor that is outside the housing 14 of the camera 10 that cooperates with one or more memories that are contained within the housing 14. In such an embodiment, such an external memory may be positioned anywhere within the vehicle.

[0027] While the above description constitutes a plurality of embodiments of the present invention, it will be appreciated that the present invention is susceptible to further modification and change without departing from the fair meaning of the accompanying claims.

CLAIMS:

1. A vehicular camera, comprising:
 - a housing;
 - a lens;
 - an image sensor positioned for receiving images from the lens;
 - a processor; and
 - a memory,wherein the memory contains a plurality of overlays, wherein the processor is programmed to:
 - receive first input data from a vehicle in which the camera is to be mounted, wherein the first input data correspond to the configuration of the vehicle, and
 - select a particular overlay to display based at least in part on the first input data received.

2. A vehicular camera as claimed in claim 1, wherein the processor is further programmed to receive second input data corresponding to the steering wheel angle, and wherein the overlays contained in the memory include overlays relating to predicted vehicle trajectory.

3. A vehicular camera as claimed in claim 2, wherein, in use, if the vehicle has a first steering gear ratio a first value is transmitted in the second input data to the camera from the vehicle when the steering wheel at full lock, and if the vehicle has a second steering gear ratio a second value is transmitted in the second input data to the camera from the vehicle when the steering wheel at full lock,
 - and wherein the processor is further programmed to determine information regarding the steering gear ratio on the vehicle based on the second input data.

4. A vehicular camera as claimed in claim 1, wherein the overlays contained in the memory include at least one first overlay corresponding to a first vehicle configuration and at least one second overlay corresponding to a second vehicle configuration.

5. A vehicular camera as claimed in claim 1, wherein the overlays contained in the memory include at least one first overlay corresponding to a first vehicle configuration and at least one common overlay corresponding to both the first vehicle configuration and a second vehicle configuration.

6. A vehicular camera as claimed in claim 1, wherein the processor determines which overlay to display by accessing a look up table using at least the first input data.

7. A vehicular camera, comprising:

a housing;

a lens;

an image sensor positioned for receiving images from the lens;

a processor; and

a memory,

wherein the memory contains a plurality of overlays, wherein the processor is programmed to select a particular overlay to display based at least in part on the configuration of the vehicle,

wherein the overlays contained in the memory include at least one first overlay corresponding to a first vehicle configuration and at least one common overlay corresponding to both the first vehicle configuration and to a second vehicle configuration.

8. A vehicular camera, comprising:

a housing;

a lens;

an image sensor positioned for receiving images from the lens;

a processor; and

a memory,

wherein the memory contains a plurality of overlays, wherein the processor is programmed to select a particular overlay to display based in part on the configuration of the vehicle,

wherein the processor is further programmed to receive input data corresponding to the steering wheel angle, and wherein the overlays contained in the memory include overlays relating to predicted vehicle trajectory,

wherein, in use, if the vehicle has a first steering gear ratio a first value is transmitted in the input data to the camera from the vehicle when the steering wheel at full lock, and if the vehicle has a second steering gear ratio a second value is transmitted in the input data to the camera from the vehicle when the steering wheel at full lock,

and wherein the processor is further programmed to determine information regarding the steering gear ratio on the vehicle based on the input data, and to select a particular overlay to display based in part on the determined information regarding the steering gear ratio.

9. A vehicular camera, comprising:

a housing;

a lens;

an image sensor positioned for receiving images from the lens;

a processor; and

a memory,

wherein the memory contains a plurality of overlays including at least one first overlay corresponding to a first vehicle configuration and at least one second overlay corresponding to a second vehicle configuration, wherein the processor is programmed to select a particular overlay to display based at least in part on the configuration of the vehicle.

1/6

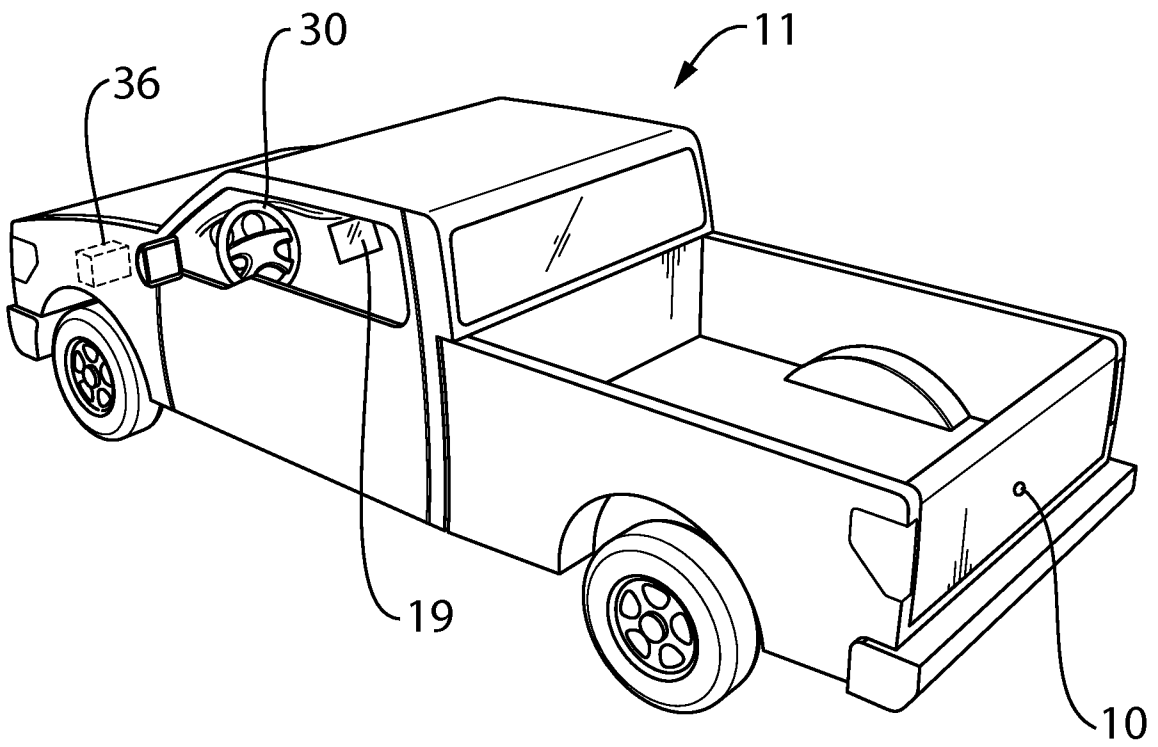

FIG. 1

2/6

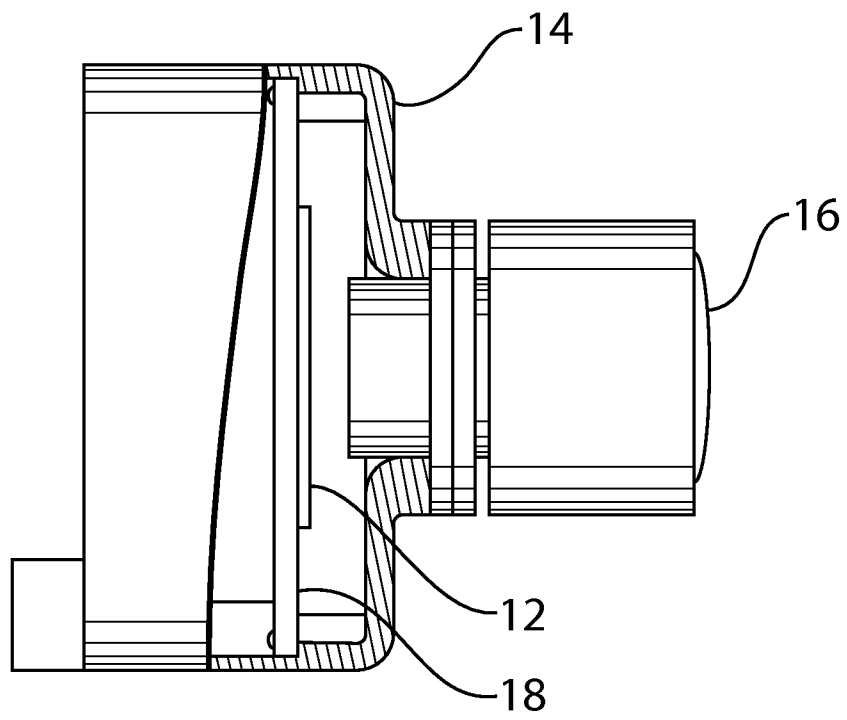

FIG. 2

3/6

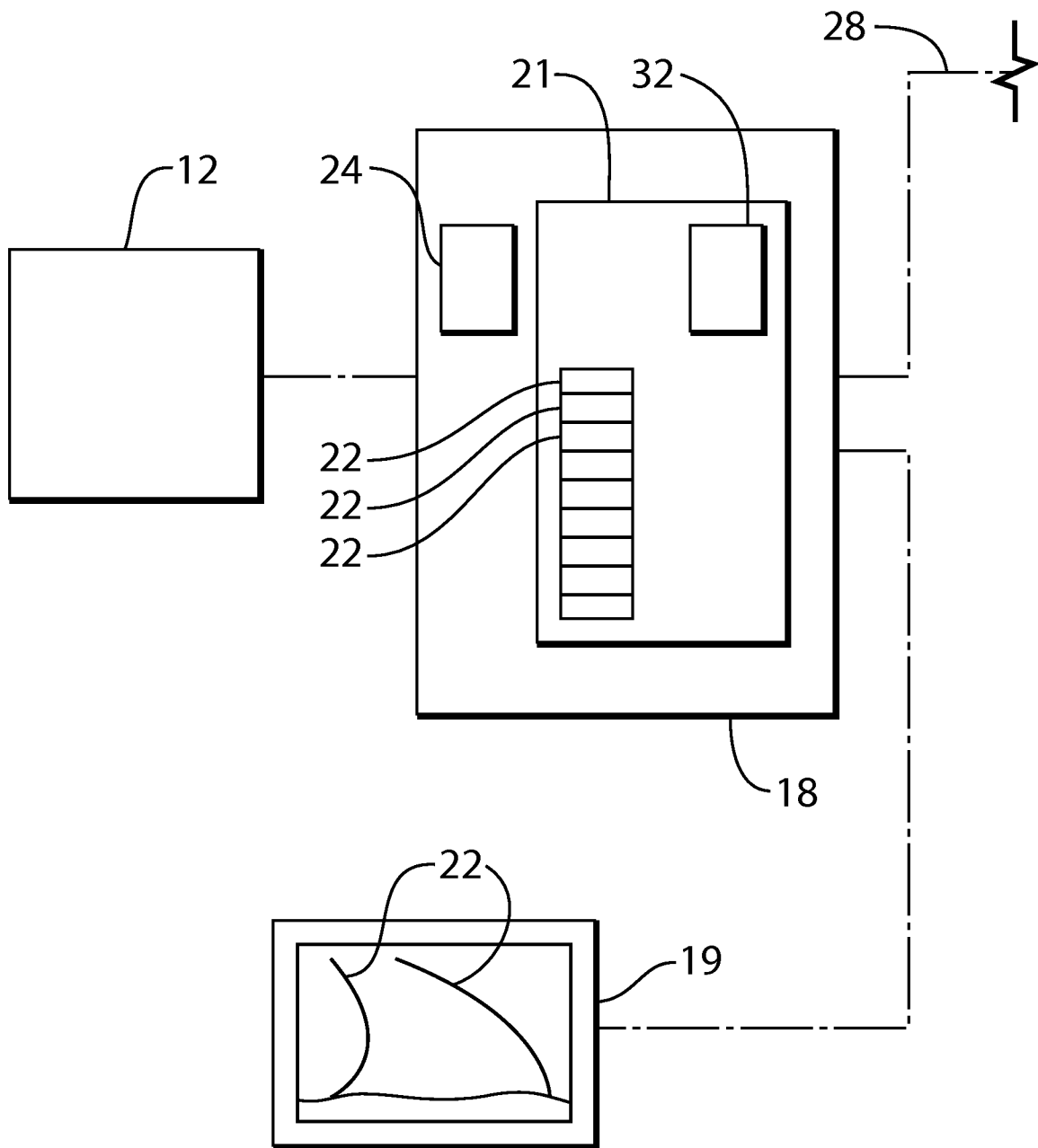

FIG. 3

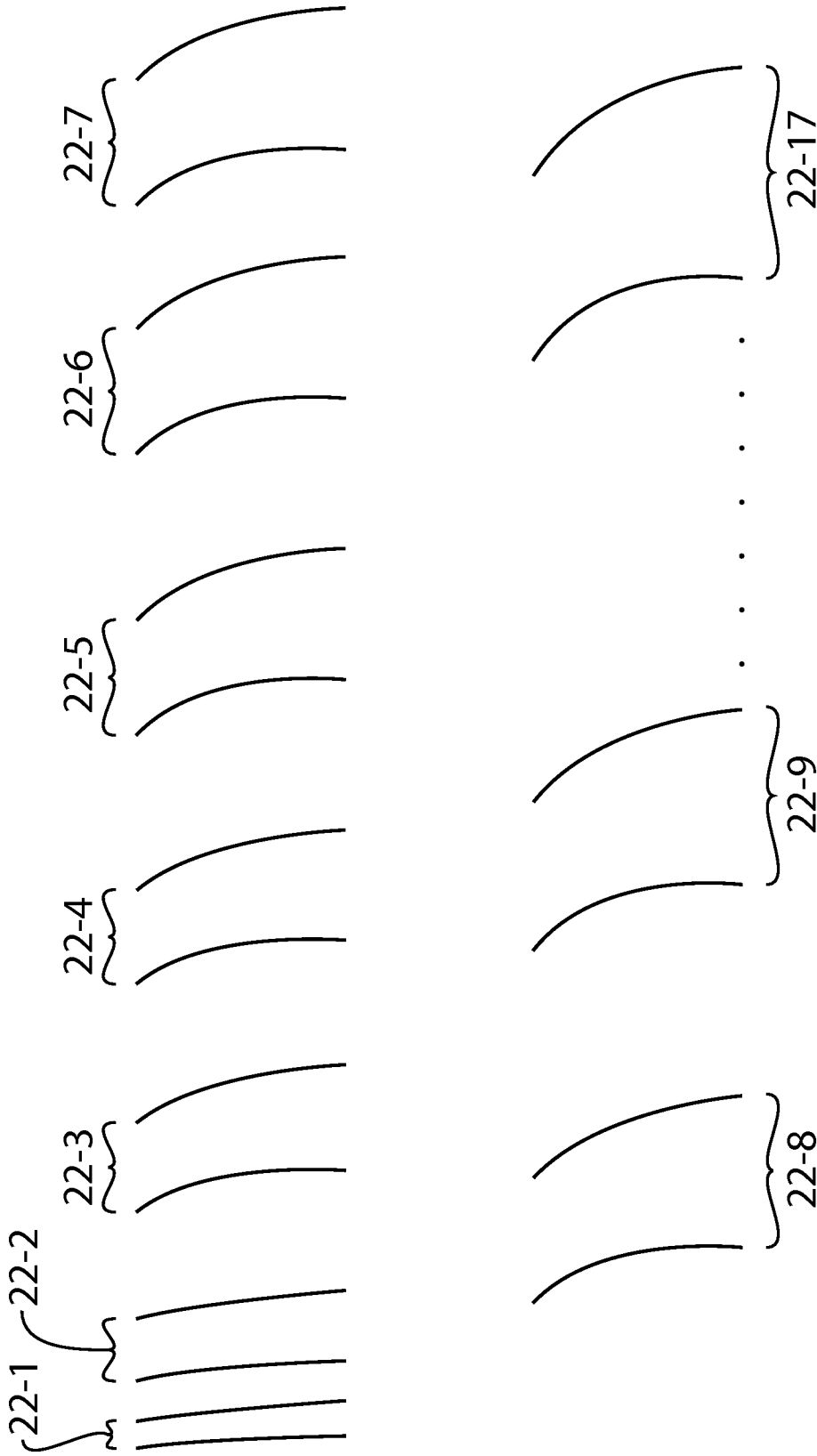

FIG. 4

OVERLAY MAP COUNT	WHEEL BASE (inch)			
	100"	110"	120"	130"
	OVERLAY RADIUS (mm)	SWA SWITCH (deg)	SWA SWITCH (deg)	SWA SWITCH (deg)
22-1	42500	30	40	40
22-2	22500	110	120	140
22-3	15800	180	190	220
22-4	12400	240	250	300
22-5	10400	300	320	370
22-6	9000	360	380	430
22-7	8100	410	430	490
22-8	7400	450	470	540
22-9	6800	490	510	590
22-10	6400	530	550	640
22-11	6000	570	600	670
22-12	5700	600	630	690
22-13	5400	630	650	
22-14	5200	650	670	
22-15	5100	670	690	
22-16	4900	690		
22-17	4800	700		

FIG. 5

32 ↙

OVERLAY MAP COUNT	WHEEL BASE		11a	11b	11c	11d	11c	11d	11e
	(inch)		100"	110"	120"	130"	120"	130"	140"
STEERING GEAR			<u>36a</u> 1	<u>36a</u> 1	<u>36a</u> 1	<u>36a</u> 1	<u>36b</u> 2	<u>36b</u> 2	<u>36b</u> 2
OVERLAY RADIUS (mm)			SWA SWITCH (deg)	SWA SWITCH (deg)	SWA SWITCH (deg)	SWA SWITCH (deg)	SWA SWITCH (deg)	SWA SWITCH (deg)	SWA SWITCH (deg)
22-1	42500		30	40	40	40	30	40	40
22-2	22500		110	120	130	140	110	120	120
22-3	15800		180	190	210	220	180	190	200
22-4	12400		240	250	270	300	240	260	270
22-5	10400		300	320	340	370	300	320	340
22-6	9000		360	380	410	430	350	380	390
22-7	8100		410	430	460	490	400	420	440
22-8	7400		450	470	500	540	440	470	490
22-9	6800		490	510	550	590	480	520	530
22-10	6400		530	550	600	640	520	550	570
22-11	6000		570	600	630	670	550	580	590
22-12	5700		600	630	660	690	570	600	
22-13	5400		630	650	680		590		
22-14	5200		650	670					
22-15	5100		670	690					
22-16	4900		690						
22-17	4800		700						

FIG. 6

INTERNATIONAL SEARCH REPORT

International application No.
PCT/US 11/36967

A. CLASSIFICATION OF SUBJECT MATTER
IPC(8) - G09G 5/00, H04N 7/00 (2011.01)
USPC - 345/636, 348/119
According to International Patent Classification (IPC) or to both national classification and IPC

B. FIELDS SEARCHED

Minimum documentation searched (classification system followed by classification symbols)
USPC: 345/636, 348/119

Documentation searched other than minimum documentation to the extent that such documents are included in the fields searched
other: USPC: 345/619, 629, 634, 636; 348/113, 118, 119; 701/1, 200 (see terms below)

Electronic data base consulted during the international search (name of data base and, where practicable, search terms used)
PubWEST(PGPB,USPT,USOC,EPAB,JPAB), GOOGLE SCHOLAR
terms: car, truck, automobile, vehicular, cam, camera, image, video, capture, sense, overlay, steering, gear, lookup, lock, ratio, angle, full lock, turn, tilt.

C. DOCUMENTS CONSIDERED TO BE RELEVANT

Category*	Citation of document, with indication, where appropriate, of the relevant passages	Relevant to claim No.
X --- Y	US 2009/0179916 A1 (Williams et al.) 16 July 2009 (16.07.2009), fig. 1-2, 10.	1-2, 4-7, 9 ----- 3, 8
Y	US 2007/0194899 A1 (Lipman) 23 August 2007 (23.08.2007), fig. 1, para [0006], [0049]-[0054].	3, 8
A	US 2010/0302368 A1 (Jeon et al.) 02 December 2010 (02.12.2010), entire document.	1-9

Further documents are listed in the continuation of Box C.

* Special categories of cited documents:

"A" document defining the general state of the art which is not considered to be of particular relevance	"T" later document published after the international filing date or priority date and not in conflict with the application but cited to understand the principle or theory underlying the invention
"E" earlier application or patent but published on or after the international filing date	"X" document of particular relevance; the claimed invention cannot be considered novel or cannot be considered to involve an inventive step when the document is taken alone
"L" document which may throw doubts on priority claim(s) or which is cited to establish the publication date of another citation or other special reason (as specified)	"Y" document of particular relevance; the claimed invention cannot be considered to involve an inventive step when the document is combined with one or more other such documents, such combination being obvious to a person skilled in the art
"O" document referring to an oral disclosure, use, exhibition or other means	"&" document member of the same patent family
"P" document published prior to the international filing date but later than the priority date claimed	

Date of the actual completion of the international search 03 September 2011 (03.09.2011)	Date of mailing of the international search report 09 SEP 2011
---------------------------------------------------------------------------------------------	--------------------------------------------------------------------------

Name and mailing address of the ISA/US Mail Stop PCT, Attn: ISA/US, Commissioner for Patents P.O. Box 1450, Alexandria, Virginia 22313-1450 Facsimile No. 571-273-3201	Authorized officer: Lee W. Young PCT Helpdesk: 571-272-4300 PCT OSP: 571-272-7774
---------------------------------------------------------------------------------------------------------------------------------------------------------------------------------	-------------------------------------------------------------------------------------------------------