



(51) International Patent Classification:

H04W 76/27 (2018.01) H04W 48/08 (2009.01)
H04W 88/06 (2009.01) H04W 48/16 (2009.01)
H04W 36/28 (2009.01)

(21) International Application Number:

PCT/CN2020/092005

(22) International Filing Date:

25 May 2020 (25.05.2020)

(25) Filing Language:

English

(26) Publication Language:

English

(71) Applicant: QUALCOMM INCORPORATED [US/US];
5775 Morehouse Drive, San Diego, California 92121-1714 (US).

(72) Inventors; and

(71) Applicants (for US only): LIN, Tianya [CN/CN]; 5775 Morehouse Drive, San Diego, California 92121-1714 (US).
ZHANG, Hao [CN/CN]; 5775 Morehouse Drive, San Diego, California 92121-1714 (US).

(74) Agent: SHANGHAI PATENT & TRADEMARK LAW OFFICE, LLC; 435 Guiping Road, Shanghai 200233 (CN).

(81) Designated States (unless otherwise indicated, for every kind of national protection available): AE, AG, AL, AM,

AO, AT, AU, AZ, BA, BB, BG, BH, BN, BR, BW, BY, BZ, CA, CH, CL, CN, CO, CR, CU, CZ, DE, DJ, DK, DM, DO, DZ, EC, EE, EG, ES, FI, GB, GD, GE, GH, GM, GT, HN, HR, HU, ID, IL, IN, IR, IS, JO, JP, KE, KG, KH, KN, KP, KR, KW, KZ, LA, LC, LK, LR, LS, LU, LY, MA, MD, ME, MG, MK, MN, MW, MX, MY, MZ, NA, NG, NI, NO, NZ, OM, PA, PE, PG, PH, PL, PT, QA, RO, RS, RU, RW, SA, SC, SD, SE, SG, SK, SL, ST, SV, SY, TH, TJ, TM, TN, TR, TT, TZ, UA, UG, US, UZ, VC, VN, WS, ZA, ZM, ZW.

(84) Designated States (unless otherwise indicated, for every kind of regional protection available): ARIPO (BW, GH, GM, KE, LR, LS, MW, MZ, NA, RW, SD, SL, ST, SZ, TZ, UG, ZM, ZW), Eurasian (AM, AZ, BY, KG, KZ, RU, TJ, TM), European (AL, AT, BE, BG, CH, CY, CZ, DE, DK, EE, ES, FI, FR, GB, GR, HR, HU, IE, IS, IT, LT, LU, LV, MC, MK, MT, NL, NO, PL, PT, RO, RS, SE, SI, SK, SM, TR), OAPI (BF, BJ, CF, CG, CI, CM, GA, GN, GQ, GW, KM, ML, MR, NE, SN, TD, TG).

Declarations under Rule 4.17:

— of inventorship (Rule 4.17(iv))

Published:

— with international search report (Art. 21(3))

(54) Title: TRIGGERING AN ATTACH PROCEDURE AFTER DISABLEMENT OF DUAL CONNECTIVITY WITH NEW RADIO MODE

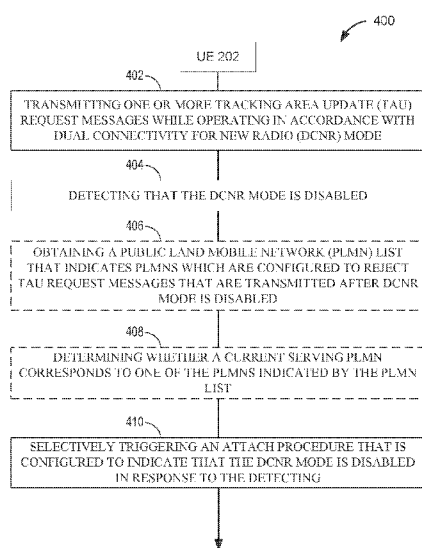

FIG. 4

(57) Abstract: In an aspect, a UE may transmit one or more tracking area update (TAU) request messages while operating in accordance with Dual Connectivity for New Radio (DCNR) mode. The UE may detect that the DCNR mode is disabled. The UE may selectively trigger an Attach procedure that is configured to indicate that the DCNR mode is disabled in response to the detection.



TRIGGERING AN ATTACH PROCEDURE AFTER DISABLEMENT OF DUAL CONNECTIVITY WITH NEW RADIO MODE

TECHNICAL FIELD

[0001] Various aspects described herein generally relate to wireless communication systems, and more particularly, to triggering an Attach procedure after disablement of Dual Connectivity with New Radio (DCNR) mode.

BACKGROUND

[0002] Wireless communication systems have developed through various generations, including a first-generation analog wireless phone service (1G), a second-generation (2G) digital wireless phone service (including interim 2.5G and 2.75G networks), a third-generation (3G) high speed data, Internet-capable wireless service and a fourth-generation (4G) service (e.g., Long Term Evolution (LTE) or WiMax). There are presently many different types of wireless communication systems in use, including Cellular and Personal Communications Service (PCS) systems. Examples of known cellular systems include the cellular Analog Advanced Mobile Phone System (AMPS), and digital cellular systems based on Code Division Multiple Access (CDMA), Frequency Division Multiple Access (FDMA), Time Division Multiple Access (TDMA), the Global System for Mobile access (GSM) variation of TDMA, etc.

[0003] A fifth generation (5G) mobile standard calls for higher data transfer speeds, greater numbers of connections, and better coverage, among other improvements. The 5G standard, according to the Next Generation Mobile Networks Alliance, is designed to provide data rates of several tens of megabits per second to each of tens of thousands of users, with 1 gigabit per second to tens of workers on an office floor. Several hundreds of thousands of simultaneous connections should be supported in order to support large sensor deployments. Consequently, the spectral efficiency of 5G mobile communications should be significantly enhanced compared to the current 4G standard. Furthermore, signaling efficiencies should be enhanced and latency should be substantially reduced compared to current standards.

[0004] 5G New Radio (NR) connectivity, or simply NR connectivity, has gained significant commercial traction in recent time. Thus, to attract more users to their network,

network operators would like to show NR connectivity to users most of the time on the user interface (UI) of the mobile device such as the user equipment (UE).

SUMMARY

- [0005] This summary identifies features of some example aspects, and is not an exclusive or exhaustive description of the disclosed subject matter. Whether features or aspects are included in, or omitted from this summary is not intended as indicative of relative importance of such features. Additional features and aspects are described, and will become apparent to persons skilled in the art upon reading the following detailed description and viewing the drawings that form a part thereof.
- [0006] An aspect is directed to a method of operating a user equipment (UE), comprising transmitting one or more tracking area update (TAU) request messages while operating in accordance with Dual Connectivity for New Radio (DCNR) mode, detecting that the DCNR mode is disabled, and selectively triggering an Attach procedure that is configured to indicate that the DCNR mode is disabled in response to the detecting.
- [0007] Another aspect is directed to a user equipment (UE), comprising means for transmitting one or more tracking area update (TAU) request messages while operating in accordance with Dual Connectivity for New Radio (DCNR) mode, means for detecting that the DCNR mode is disabled, and means for selectively triggering an Attach procedure that is configured to indicate that the DCNR mode is disabled in response to the detection.
- [0008] Another aspect is directed to a user equipment (UE), comprising a memory, at least one communications interface, and at least one processor communicatively coupled to the memory, the at least one communications interface, the at least one processor configured to transmit one or more tracking area update (TAU) request messages while operating in accordance with Dual Connectivity for New Radio (DCNR) mode, detect that the DCNR mode is disabled, and selectively trigger an Attach procedure that is configured to indicate that the DCNR mode is disabled in response to the detection.
- [0009] Another aspect is directed to a non-transitory computer-readable medium containing instructions stored thereon, which, when executed by a user equipment (UE), cause the UE to perform operations, the instructions comprising at least one instruction to cause the UE to at least one instruction to cause the UE to transmit one or more tracking area update (TAU) request messages while operating in accordance with Dual Connectivity

for New Radio (DCNR) mode, at least one instruction to cause the UE to detect that the DCNR mode is disabled, and at least one instruction to cause the UE to selectively trigger an Attach procedure that is configured to indicate that the DCNR mode is disabled in response to the detection.

[0010] Other objects and advantages associated with the aspects disclosed herein will be apparent to those skilled in the art based on the accompanying drawings and detailed description.

BRIEF DESCRIPTION OF THE DRAWINGS

[0011] The accompanying drawings are presented to aid in the description of examples of one or more aspects of the disclosed subject matter and are provided solely for illustration of the examples and not limitation thereof:

[0012] FIG. 1 illustrates an exemplary wireless communications system in accordance with one or more aspects of the disclosure;

[0013] FIG. 2 is a simplified block diagram of several sample aspects of components that may be employed in wireless communication nodes and configured to support communication in accordance with one or more aspects of the disclosure;

[0014] FIG. 3 illustrates a conventional TAU procedure.

[0015] FIG. 4 illustrates an exemplary process of wireless communication, according to aspects of the disclosure.

[0016] FIG. 5 illustrates an example implementation of the process of FIG. 4 in accordance with an embodiment of the disclosure.

[0017] FIG. 6 illustrates another example implementation of the process of FIG. 4 in accordance with an embodiment of the disclosure.

[0018] FIG. 7 illustrates another example implementation of the process of FIG. 4 in accordance with an embodiment of the disclosure.

[0019] FIG. 8 illustrates an example user equipment apparatus represented as a series of interrelated functional modules connected by a common bus in accordance with an embodiment of the disclosure.

DETAILED DESCRIPTION

[0020] Aspects of the subject matter are provided in the following description and related drawings directed to specific examples of the disclosed subject matter. Alternates may

be devised without departing from the scope of the disclosed subject matter. Additionally, well-known elements will not be described in detail or will be omitted so as not to obscure the relevant details.

- [0021] The word “exemplary” is used herein to mean “serving as an example, instance, or illustration.” Any aspect described herein as “exemplary” is not necessarily to be construed as preferred or advantageous over other aspects. Likewise, the term “aspects” does not require that all aspects include the discussed feature, advantage, or mode of operation.
- [0022] The terminology used herein describes particular aspects only and should not be construed to limit any aspects disclosed herein. As used herein, the singular forms “a,” “an,” and “the” are intended to include the plural forms as well, unless the context clearly indicates otherwise. Those skilled in the art will further understand that the terms “comprises,” “comprising,” “includes,” and/or “including,” as used herein, specify the presence of stated features, integers, steps, operations, elements, and/or components, but do not preclude the presence or addition of one or more other features, integers, steps, operations, elements, components, and/or groups thereof.
- [0023] Further, various aspects may be described in terms of sequences of actions to be performed by, for example, elements of a computing device. Those skilled in the art will recognize that various actions described herein can be performed by specific circuits (e.g., an application specific integrated circuit (ASIC)), by program instructions being executed by one or more processors, or by a combination of both. Additionally, these sequences of actions described herein can be considered to be embodied entirely within any form of non-transitory computer-readable medium having stored thereon a corresponding set of computer instructions that upon execution would cause an associated processor to perform the functionality described herein. Thus, the various aspects described herein may be embodied in a number of different forms, all of which have been contemplated to be within the scope of the claimed subject matter. In addition, for each of the aspects described herein, the corresponding form of any such aspects may be described herein as, for example, “logic configured to” and/or other structural components configured to perform the described action.
- [0024] As used herein, the terms “user equipment” (UE) and “base station” are not intended to be specific or otherwise limited to any particular Radio Access Technology (RAT), unless otherwise noted. In general, such UEs may be any wireless communication

device (e.g., a mobile phone, router, tablet computer, laptop computer, tracking device, Internet of Things (IoT) device, etc.) used by a user to communicate over a wireless communications network. A UE may be mobile or may (e.g., at certain times) be stationary, and may communicate with a Radio Access Network (RAN). As used herein, the term “UE” may be referred to interchangeably as an “access terminal” or “AT,” a “client device,” a “wireless device,” a “subscriber device,” a “subscriber terminal,” a “subscriber station,” a “user terminal” or UT, a “mobile terminal,” a “mobile station,” or variations thereof. Generally, UEs can communicate with a core network via a RAN, and through the core network the UEs can be connected with external networks such as the Internet and with other UEs. Of course, other mechanisms of connecting to the core network and/or the Internet are also possible for the UEs, such as over wired access networks, WiFi networks (e.g., based on Institute of Electrical and Electronics Engineers (IEEE) 802.11, etc.) and so on.

[0025] A base station may operate according to one of several RATs in communication with UEs depending on the network in which it is deployed, and may be alternatively referred to as an Access Point (AP), a Network Node, a NodeB, an evolved NodeB (eNB), a general Node B (gNodeB, gNB), etc. In addition, in some systems a base station may provide edge node signaling functions while in other systems it may provide additional control and/or network management functions.

[0026] UEs can be embodied by any of a number of types of devices including but not limited to printed circuit (PC) cards, compact flash devices, external or internal modems, wireless or wireline phones, smartphones, tablets, tracking devices, asset tags, and so on. A communication link through which UEs can send signals to a RAN is called an uplink channel (e.g., a reverse traffic channel, a reverse control channel, an access channel, etc.). A communication link through which the RAN can send signals to UEs is called a downlink or forward link channel (e.g., a paging channel, a control channel, a broadcast channel, a forward traffic channel, etc.). As used herein the term traffic channel (TCH) can refer to either an uplink / reverse or downlink / forward traffic channel.

[0027] FIG. 1 illustrates an exemplary wireless communications system 100 according to one or more aspects. The wireless communications system 100, which may also be referred to as a wireless wide area network (WWAN), may include various base stations 102 and various UEs 104. The base stations 102 may include macro cells (high power cellular

base stations) and/or small cells (low power cellular base stations). The macro cells may include Evolved NodeBs (eNBs) where the wireless communications system 100 corresponds to an LTE network, gNodeBs (gNBs) where the wireless communications system 100 corresponds to a 5G network, and/or a combination thereof, and the small cells may include femtocells, picocells, microcells, etc.

- [0028] The base stations 102 may collectively form a Radio Access Network (RAN) and interface with an Evolved Packet Core (EPC) or Next Generation Core (NGC) through backhaul links. In addition to other functions, the base stations 102 may perform functions that relate to one or more of transferring user data, radio channel ciphering and deciphering, integrity protection, header compression, mobility control functions (e.g., handover, dual connectivity), inter-cell interference coordination, connection setup and release, load balancing, distribution for non-access stratum (NAS) messages, NAS node selection, synchronization, RAN sharing, multimedia broadcast multicast service (MBMS), subscriber and equipment trace, RAN information management (RIM), paging, positioning, and delivery of warning messages. The base stations 102 may communicate with each other directly or indirectly (e.g., through the EPC / NGC) over backhaul links 134, which may be wired or wireless.
- [0029] The base stations 102 may wirelessly communicate with the UEs 104. Each of the base stations 102 may provide communication coverage for a respective geographic coverage area 110. In an aspect, although not shown in FIG. 1, coverage areas 110 may be subdivided into a plurality of cells (e.g., three), or sectors, each cell corresponding to a single antenna or array of antennas of a base station 102. As used herein, the term “cell” or “sector” may correspond to one of a plurality of cells of a base station 102, or to the base station 102 itself, depending on the context.
- [0030] While neighbor macro cell geographic coverage areas 110 may partially overlap (e.g., in a handover region), some of the geographic coverage areas 110 may be substantially overlapped by a larger geographic coverage area 110. For example, a small cell base station 102' may have a coverage area 110' that substantially overlaps with the coverage area 110 of one or more macro cell base stations 102. A network that includes both small cell and macro cells may be known as a heterogeneous network. A heterogeneous network may also include Home eNBs (HeNBs) and/or Home gNodeBs, which may provide service to a restricted group known as a closed subscriber group (CSG). The communication links 120 between the base stations 102 and the UEs 104 may include

uplink (UL) (also referred to as reverse link) transmissions from a UE 104 to a base station 102 and/or downlink (DL) (also referred to as forward link) transmissions from a base station 102 to a UE 104. The communication links 120 may use multiple input multiple output (MIMO) antenna technology, including spatial multiplexing, beamforming, and/or transmit diversity. The communication links may be through one or more carriers. Allocation of carriers may be asymmetric with respect to DL and UL (e.g., more or less carriers may be allocated for DL than for UL).

- [0031] The wireless communications system 100 may further include a wireless local area network (WLAN) access point (AP) 150 in communication with WLAN stations (STAs) 152 via communication links 154 in an unlicensed frequency spectrum (e.g., 5 GHz). When communicating in an unlicensed frequency spectrum, the WLAN STAs 152 and/or the WLAN AP 150 may perform a clear channel assessment (CCA) prior to communicating in order to determine whether the channel is available.
- [0032] The small cell base station 102' may operate in a licensed and/or an unlicensed frequency spectrum. When operating in an unlicensed frequency spectrum, the small cell base station 102' may employ LTE or 5G technology and use the same 5 GHz unlicensed frequency spectrum as used by the WLAN AP 150. The small cell base station 102', employing LTE / 5G in an unlicensed frequency spectrum, may boost coverage to and/or increase capacity of the access network. LTE in an unlicensed spectrum may be referred to as LTE-unlicensed (LTE-U), licensed assisted access (LAA), or MulteFire.
- [0033] The wireless communications system 100 may further include a mmW base station 180 that may operate in mmW frequencies and/or near mmW frequencies in communication with a UE 182. Extremely high frequency (EHF) is part of the radio frequency (RF) range in the electromagnetic spectrum. EHF has a range of 30 GHz to 300 GHz and a wavelength between 1 millimeter and 10 millimeters. Radio waves in this band may be referred to as a millimeter wave. Near mmW may extend down to a frequency of 3 GHz with a wavelength of 100 millimeters. The super high frequency (SHF) band extends between 3 GHz and 30 GHz, also referred to as centimeter wave. Communications using the mmW/near mmW radio frequency band have high path loss and a relatively short range. The mmW base station 180 may utilize beamforming 184 with the UE 182 to compensate for the extremely high path loss and short range. Further, it will be appreciated that in alternative configurations, one or more base

stations 102 may also transmit using mmW or near mmW and beamforming. Accordingly, it will be appreciated that the foregoing illustrations are merely examples and should not be construed to limit the various aspects disclosed herein.

[0034] The wireless communications system 100 may further include one or more UEs, such as UE 190, that connects indirectly to one or more communication networks via one or more device-to-device (D2D) peer-to-peer (P2P) links. In the embodiment of FIG. 1, UE 190 has a D2D P2P link 192 with one of the UEs 104 connected to one of the base stations 102 (e.g., through which UE 190 may indirectly obtain cellular connectivity) and a D2D P2P link 194 with WLAN STA 152 connected to the WLAN AP 150 (through which UE 190 may indirectly obtain WLAN-based Internet connectivity). In an example, the D2D P2P links 192-194 may be supported with any well-known D2D radio access technology (RAT), such as LTE Direct (LTE-D), WiFi Direct (WiFi-D), Bluetooth, and so on. Any of the base stations 102, 102', 180 may send measurement requests (e.g., measurement control order (MCO)) to the UEs 104, 182, 190, and the UE's 104, 182, 190 may respond with measurement reports accordingly.

[0035] FIG. 2 illustrates several sample components (represented by corresponding blocks) that may be incorporated into an apparatus 202 and an apparatus 204 (corresponding to, for example, a UE and a base station (e.g., eNB, gNB), respectively, to support the operations as disclosed herein. As an example, the apparatus 202 may correspond to a UE, and the apparatus 204 may correspond to a network node such as a gNB and/or an eNB. It will be appreciated that the components may be implemented in different types of apparatuses in different implementations (e.g., in an ASIC, in a System-on-Chip (SoC), etc.). The illustrated components may also be incorporated into other apparatuses in a communication system. For example, other apparatuses in a system may include components similar to those described to provide similar functionality. Also, a given apparatus may contain one or more of the components. For example, an apparatus may include multiple transceiver components that enable the apparatus to operate on multiple carriers and/or communicate via different technologies.

[0036] The apparatus 202 and the apparatus 204 each may include at least one wireless communication device (represented by the communication devices 208 and 214) for communicating with other nodes via at least one designated RAT (e.g., LTE, NR). Each communication device 208 may include at least one transmitter (represented by the transmitter 210) for transmitting and encoding signals (e.g., messages, indications,

information, and so on) and at least one receiver (represented by the receiver 212) for receiving and decoding signals (e.g., messages, indications, information, pilots, and so on). Each communication device 214 may include at least one transmitter (represented by the transmitter 216) for transmitting signals (e.g., messages, indications, information, pilots, and so on) and at least one receiver (represented by the receiver 218) for receiving signals (e.g., messages, indications, information, and so on).

[0037] A transmitter and a receiver may comprise an integrated device (e.g., embodied as a transmitter circuit and a receiver circuit of a single communication device) in some implementations, may comprise a separate transmitter device and a separate receiver device in some implementations, or may be embodied in other ways in other implementations. In an aspect, a transmitter may include a plurality of antennas, such as an antenna array, that permits the respective apparatus to perform transmit “beamforming,” as described further herein. Similarly, a receiver may include a plurality of antennas, such as an antenna array, that permits the respective apparatus to perform receive beamforming, as described further herein. In an aspect, the transmitter and receiver may share the same plurality of antennas, such that the respective apparatus can only receive or transmit at a given time, not both at the same time. A wireless communication device (e.g., one of multiple wireless communication devices) of the apparatus 204 may also comprise a Network Listen Module (NLM) or the like for performing various measurements.

[0038] The apparatus 204 may include at least one communication device (represented by the communication device 220) for communicating with other nodes. For example, the communication device 220 may comprise a network interface (e.g., one or more network access ports) configured to communicate with one or more network entities via a wire-based or wireless backhaul connection. In some aspects, the communication device 220 may be implemented as a transceiver configured to support wire-based or wireless signal communication. This communication may involve, for example, sending and receiving messages, parameters, or other types of information. Accordingly, in the example of FIG. 2, the communication device 220 is shown as comprising a transmitter 222 and a receiver 224 (e.g., network access ports for transmitting and receiving).

[0039] The apparatuses 202 and 204 may also include other components used in conjunction with the operations as disclosed herein. The apparatus 202 may include a processing

system 232 for providing functionality relating to, for example, communication with the network. The apparatus 204 may include a processing system 234 for providing functionality relating to, for example, communication with the UEs. In an aspect, the processing systems 232 and 234 may include, for example, one or more general purpose processors, multi-core processors, ASICs, digital signal processors (DSPs), field programmable gate arrays (FPGA), or other programmable logic devices or processing circuitry.

[0040] The apparatuses 202 and 204 may include measurement components 252 and 254 that may be used to obtain channel related measurements. The measurement component 252 may measure one or more downlink (DL) signals such as channel state information reference signal (CSI-RS), phase tracking reference signal (PTRS), primary synchronization signal (PSS), secondary synchronization signal (SSS), demodulation reference signal (DMRS), etc. The measurement component 254 may measure one or more uplink (UL) signals such as DMRS, sounding reference signal (SRS), etc.

[0041] The apparatuses 202 and 204 may include memory components 238 and 240 (e.g., each including a memory device), respectively, for maintaining information (e.g., information indicative of reserved resources, thresholds, parameters, and so on). In various implementations, memory 238 can comprise a computer-readable medium storing one or more computer-executable instructions for a user equipment (UE) where the one or more instructions instruct apparatus 202 (e.g., processing system 232 in combination with communications device 208 and/or other aspects of apparatus 202) to perform any of the functions of FIGS. 3, 4, and 5. In addition, the apparatuses 202 and 204 may include user interface devices 244 and 246, respectively, for providing indications (e.g., audible and/or visual indications) to a user and/or for receiving user input (e.g., upon user actuation of a sensing device such a keypad, a touch screen, a microphone, and so on).

[0042] For convenience, the apparatuses 202 and 204 are shown in FIG. 2 as including various components that may be configured according to the various examples described herein. It will be appreciated, however, that the illustrated blocks may have different functionality in different designs.

[0043] The components of FIG. 2 may be implemented in various ways. In some implementations, the components of FIG. 2 may be implemented in one or more circuits such as, for example, one or more processors and/or one or more ASICs (which may

include one or more processors). Here, each circuit may use and/or incorporate at least one memory component for storing information or executable code used by the circuit to provide this functionality. For example, some or all of the functionality represented by blocks 208, 232, 238, and 244 may be implemented by processor and memory component(s) of the apparatus 202 (e.g., by execution of appropriate code and/or by appropriate configuration of processor components). Similarly, some or all of the functionality represented by blocks 214, 220, 234, 240, and 246 may be implemented by processor and memory component(s) of the apparatus 204 (e.g., by execution of appropriate code and/or by appropriate configuration of processor components).

- [0044] In an aspect, the apparatus 204 may correspond to a “small cell” or a Home gNodeB. The apparatus 202 may transmit and receive messages via a wireless link 260 with the apparatus 204, the messages including information related to various types of communication (e.g., voice, data, multimedia services, associated control signaling, etc.). The wireless link 260 may operate over a communication medium of interest, shown by way of example in FIG. 2 as the medium 262, which may be shared with other communications as well as other RATs. A medium of this type may be composed of one or more frequency, time, and/or space communication resources (e.g., encompassing one or more channels across one or more carriers) associated with communication between one or more transmitter / receiver pairs, such as the apparatus 204 and the apparatus 202 for the medium 262.
- [0045] In general, the apparatus 202 and the apparatus 204 may operate via the wireless link 260 according to one or more radio access types, such as LTE, LTE-U, or NR, depending on the network in which they are deployed. These networks may include, for example, different variants of CDMA networks (e.g., LTE networks, NR networks, etc.), TDMA networks, FDMA networks, Orthogonal FDMA (OFDMA) networks, Single-Carrier FDMA (SC-FDMA) networks, and so on.
- [0046] A UE may be capable of operating in multiple radio access technologies (RATs). For example, a UE may be capable of operating in a first RAT (e.g., NR) and in a second RAT (e.g., LTE). These are merely examples, and first and second RATs may be any of the RATs currently known (e.g., WiMax, CDMA, WCDMA, UTRA, Evolved Universal Terrestrial Radio Access (E-UTRA), GSM, FDMA, GSM, TDMA, etc.).
- [0047] Also, a UE may be may be capable of operating in multiple RATs at the same time. For example, a UE that can operate in both LTE and NR simultaneously is an E-UTRA-

New Radio Dual Connectivity (ENDC) capable UE. Note that ENDC is an example of Multi-RAT DC (MRDC) capability. In general, when an MRDC capable UE is operating in two RATs, it may be communicating with a base station (e.g., eNB) of a first RAT (e.g., LTE) and with a base station (e.g., gNB) of a second RAT (e.g., NR). In some designs, MRDC capability (or lack thereof) may be indicated by the UE to the network via a Dual Connectivity with New Radio (DCNR) bit in an Attach message (e.g., DCNR bit = 1 to indicate DCNR mode enabled, and DCNR bit = 0 to indicate DCNR mode disabled).

- [0048] Note that even if a UE is able to operate in first and second RATs, it may be limited in the bands that it can operate. For example, LTE defines bands 1–88 and NR defines bands n1–n95 in frequency range (FR) 1 and n257–n268 in FR2. A UE may be limited in the LTE bands and/or limited in the NR bands it supports. Also, even if the UE is capable of supporting a given LTE band (referred to herein, for ease of reference, as band X) and a given NR band (referred to herein, for ease of reference, as band Y), it may not be capable of simultaneously supporting band X and band Y, that is, the UE may not be MRDC capable in band X and band Y as only certain band combinations may be supported in MRDC for a given UE.
- [0049] For ease of reference, when a UE is capable of operating in a first band of a first RAT (e.g., LTE) and in a second band of a second RAT (e.g., NR) simultaneously, the UE may be referred to as being MRDC capable in first and second RATs. Note that the first and second bands may or may not overlap. When the UE operates in the first RAT, it may communicate with a network node (e.g., base station, eNB, etc.) of the first RAT. Similarly, when the UE operates in the second RAT, it may communicate with a network node (e.g., base station, gNB, etc.) of the second RAT.
- [0050] The UE may be capable of operating in a standalone (SA) or in a non-standalone (NSA) mode within a given RAT. When operating in the SA mode, the UE is able to exchange both control and data plane information with the network node and/or the core network of the given RAT (e.g., NR). When operating in the NSA mode, the UE is communicating with network nodes of the first and second RATs. In the NSA mode, the UE can exchange data plane information with the network nodes of both the first RAT (e.g., LTE) and the second RAT (e.g., NR). However, the control plane information is exchanged only with the network node of the first RAT (e.g., LTE).

[0051] Various LTE network operators across many cities have recently experienced an issue whereby UE data icons appear and disappear frequently. After some investigation by the inventors of the subject application, the root cause for at least some part of this problem was determined to be due to a tracking area update (TAU) reject message with a cause_value = 0 (0x9) (e.g., cause_value = 9 indicates that the UE identity cannot be derived by the network) that is triggered after the UE disables DCNR mode (or more specifically, disables NR5G operation). This phenomenon was further detected to be present with respect to some but not all public land mobile networks (PLMNs). The related logs associated with the above-noted TAU reject message are as follows:

- LTE NAS EMM Plain OTA Incoming Message -- **Tracking area update reject** Msg
- cause_value = 9 (0x9) (UE identity cannot be derived by the network)

[0052] FIG. 3 illustrates a conventional TAU procedure 300 whereby the above-noted TAU reject message is received at the UE. In FIG. 3, a UE 202 is NR capable and is operating in NSA mode, and LTE cell 204 supports NSA mode. While operation of the LTE cell 204 is described below, it will be appreciated that for some messaging the LTE cell 204 may operate as a relay to an LTE core network component which processes certain message such as Attach messages, etc.

[0053] Referring to FIG. 3, at 302, UE 202 is operating in accordance with DCNR mode and transmits an Attach request to LTE cell 204 with DCNR=1, and at 304, the LTE cell 204 responds with an Attach accept message. At 306, UE 202 transmits a TAU request message with DCNR=1, and at 308, the LTE cell 204 responds with a TAU accept message. At 310, UE 202 detects that NR 5G operation is disabled, which in turn disables the DCNR mode. At 312, UE 202 transmits a TAU request message subsequent to the DCNR disablement at 310 with DCNR=0. However, the LTE network in this case cannot identify UE 202 based on the TAU request from 312, and as such the LTE cell responds with a TAU reject message (#9) at 314. As noted above, these TAU reject messages (#9) appear to be causing UE data icons to appear and disappear frequently, which degrades system performance as well as user experience.

[0054] Embodiments of the disclosure are directed to triggering of an Attach procedure in response to detection of DCNR mode disablement at the UE. This triggering may be either automatic or selective. In some designs, triggering of an Attach procedure may

reduce or avoid the anomalous operation whereby some PLMNs cannot recognize a TAU request with DCNR=0 following DCNR disablement, and as such provides the technical advantages of improving system performance as well as user experience (e.g., in particular, avoiding the UE data icon flickering that is currently a problem in some LTE networks).

[0055] FIG. 4 illustrates an exemplary process 400 of wireless communication, according to aspects of the disclosure. The process 400 may be performed by a UE (e.g., any of the UEs described herein). In an example, the UE performing the process 400 of FIG. 4 is NR capable and is operating in NSA mode.

[0056] At 402, the UE (e.g., transmitter 210, etc.) transmits one or more TAU request messages while operating in accordance with DCNR mode (e.g., DCNR bit set to 1, or DCNR=1). While not shown expressly in FIG. 4, the TAU request message(s) will generally result in TAU accept messages being received from a current serving cell.

[0057] At 404, the UE (e.g., processing system 232) detects that the DCNR mode is disabled.

[0058] At 406, the UE (e.g., processing system 232, transmitter 210, receiver 212, etc.) optionally obtains a PLMN list that indicates PLMNs which are configured to reject TAU request messages that are transmitted after the DCNR mode is disabled. In some designs, the PLMN list is implemented as a white list that identifies PLMNs that send TAU accept messages to such TAU request messages, whereas in other designs the PLMN list is implemented as a black list that identifies PLMNs that send TAU reject messages to such TAU request messages. In some designs, at least part of the PLMN list may be locally populated at the UE, whereas in other designs at least part of the PLMN list may be received from an external source (e.g., downloaded from a server, crowd-sourced from other UEs, etc.).

[0059] At 408, the UE (e.g., processing system 232, etc.) optionally determines whether a current serving PLMN corresponds to one of the PLMNs indicated by the PLMN list.

[0060] At 410, the UE (e.g., processing system 232, transmitter 210, receiver 212, etc.) selectively triggers an Attach procedure that is configured to indicate that the DCNR mode is disabled in response to the detecting. In some designs, the Attach procedure is triggered automatically in response to the detection from 404. In other designs, the Attach procedure is triggered based on a combination of the detection from 404 and one or more secondary criteria. For example, in a scenario where optional 406-408 are performed, the selectively triggering may trigger the Attach procedure at 410 if the

current serving PLMN is determined to correspond to one of the PLMNs indicated by the PLMN list, and the selectively triggering may not trigger the Attach procedure at 410 if the current serving PLMN is not determined to correspond to one of the PLMNs indicated by the PLMN list.

[0061] FIG. 5 illustrates an example implementation 500 of the process 400 of FIG. 4 in accordance with an embodiment of the disclosure. In FIG. 5, a UE 202 is NR capable and is operating in NSA mode, and LTE cell 204 supports NSA mode. While operation of the LTE cell 204 is described below, it will be appreciated that for some messaging the LTE cell 204 may operate as a relay to an LTE core network component which processes certain message such as Attach messages, etc.

[0062] Referring to FIG. 5, at 502, UE 202 is operating in accordance with DCNR mode and transmits an Attach request to LTE cell 204 with DCNR=1, and at 504, the LTE cell 204 responds with an Attach accept message. At 506 (e.g., as in 402 of FIG. 4), UE 202 transmits a TAU request message with DCNR=1, and at 508, the LTE cell 204 responds with a TAU accept message. At 510 (e.g., as in 404 of FIG. 4), UE 202 detects that NR 5G operation is disabled, which in turn disables the DCNR mode. At 512 (e.g., as in 410 of FIG. 4), UE 202 transmits an Attach request to LTE cell 204 with DCNR=0, and at 514, the LTE cell 204 responds with an Attach accept message. The Attach procedure at 514-516 results in the LTE network associated with the LTE cell 204 being capable of identifying subsequent TAU request messages set to DCNR=0, such that the TAU reject (#9) phenomenon depicted at 314 of FIG. 3 can be avoided. Accordingly, at 516, UE 202 transmits a TAU request message with DCNR=0, and at 518, the LTE cell 204 responds with a TAU accept message.

[0063] FIG. 6 illustrates an example implementation 600 of the process 400 of FIG. 4 in accordance with another embodiment of the disclosure. In FIG. 6, a UE 202 is NR capable and is operating in NSA mode, and LTE cell 204 supports NSA mode. While operation of the LTE cell 204 is described below, it will be appreciated that for some messaging the LTE cell 204 may operate as a relay to an LTE core network component which processes certain message such as Attach messages, etc. While FIG. 5 depicts an example where the DCNR disablement at 510 automatically triggers the Attach procedure at 512-514, the process 600 of FIG. 6 relates to an example whereby a PLMN list is used as a secondary criterion to determine whether to perform the Attach procedure at 512-514. For example, performing the Attach procedure at 512-514 in a

more selective manner is somewhat more complicated to implement, but may reduce system overhead in the sense that Attach procedures can be skipped with respect to PLMNs that do not experience the TAU reject (#9) phenomenon noted above.

[0064] Referring to FIG. 6, at 602, UE 202 is operating in accordance with DCNR mode and transmits an Attach request to LTE cell 204 with DCNR=1, and at 604, the LTE cell 204 responds with an Attach accept message. At 606 (e.g., as in 402 of FIG. 4), UE 202 transmits a TAU request message with DCNR=1, and at 608, the LTE cell 204 responds with a TAU accept message. At 610 (e.g., as in 404 of FIG. 4), UE 202 detects that NR 5G operation is disabled, which in turn disables the DCNR mode. At 612 (e.g., as in optional 406-408 of FIG. 4), UE 202 determines whether a current serving PLMN associated with the LTE cell 204 is on a PLMN list (e.g., in this case, the PLMN list is a black list locally populated at the UE that lists PLMNs that suffer from the TAU reject (#9) phenomenon noted above). If the current serving PLMN is determined to be on the PLMN list at 612, the process advances to 512 where the Attach procedure is performed. Otherwise, if the current serving PLMN is not determined to be on the PLMN list at 612, at 614, UE 202 transmits a TAU request message with DCNR=0. In this example, the LTE network cannot identify UE 202 based on the TAU request from 614, and as such the LTE cell responds with a TAU reject message (#9) at 616. At 618, UE 202 adds the current serving PLMN to the PLMN list. Accordingly, the next time DCNR mode is disabled for the UE while being served by this particular PLMN, the Attach procedure is triggered instead of the TAU procedure such that the TAU reject (#9) phenomenon can be avoided.

[0065] FIG. 7 illustrates an example implementation 700 of the process 400 of FIG. 4 in accordance with another embodiment of the disclosure. The process 700 of FIG. 7 is similar to the process 600 of FIG. 6, such that 702-714 of FIG. 7 correspond to 602-614 of FIG. 6, respectively. As will be appreciated, the PLMN list will become more accurate over time as the UE interacts with more PLMNs. Accordingly, at 716, the TAU request message with DCNR=0 at 714 results in a TAU accept message rather than a TAU reject message (#9) as in 616 of FIG. 6.

[0066] Referring to FIGS. 4-7, in some designs, the optional PLMN list may be reset in response to a triggering event, such as the UE powering off or a Subscriber Identity Module (SIM) card of the UE being removed. In an example, this PLMN list reset

operation may align management of the PLMN list with other types of forbidden PLMN lists that are defined in one or more relevant 3GPP standards.

- [0067] While various communications are described with respect to FIGS. 4-7 as occurring between a UE and a respective LTE cell, it will be appreciated that in some cases the respective cell may be an intermediate entity in association with the respective end-to-end communications. For example, in an uplink direction, the UE may in some cases wirelessly transmit a message to the cell which in turn forwards the message to another entity (e.g., a core network entity, such as a PGW). In another example, in a downlink direction, an external entity (e.g., a core network entity, such as a PGW) may transmit a message to the cell which in turn wirelessly transmits the message to the UE.
- [0068] FIG. 8 illustrates an example user equipment apparatus 800 represented as a series of interrelated functional modules connected by a common bus in accordance with an embodiment of the disclosure. Each of the modules may be implemented in hardware or as a combination of hardware and software. For example, the modules may be implemented as any combination of the modules of the apparatus 202 of FIG. 2. A module for transmitting 802 may correspond at least in some aspects to transmitter 210. A module for detecting 804 may correspond at least in some aspects to processing system 232. An optional module for obtaining 806 may correspond at least in some aspects to processing system 232, memory 238, transmitter 210 and/or receiver 212. An optional module for determining 808 may correspond at least in some aspects to processing system 232. A module for selectively triggering may correspond at least in some aspects to processing system 232.
- [0069] The functionality of the modules of FIG. 8 may be implemented in various ways consistent with the teachings herein. In some designs, the functionality of these modules may be implemented as one or more electrical components. In some designs, the functionality of these blocks may be implemented as a processing system including one or more processor components. In some designs, the functionality of these modules may be implemented using, for example, at least a portion of one or more integrated circuits (e.g., an ASIC). As discussed herein, an integrated circuit may include a processor, software, other related components, or some combination thereof. Thus, the functionality of different modules may be implemented, for example, as different subsets of an integrated circuit, as different subsets of a set of software modules, or a combination thereof. Also, it will be appreciated that a given subset (e.g., of an

integrated circuit and/or of a set of software modules) may provide at least a portion of the functionality for more than one module.

- [0070] In addition, the components and functions represented by FIG. 8, as well as other components and functions described herein, may be implemented using any suitable means. Such means also may be implemented, at least in part, using corresponding structure as taught herein. For example, the components described above in conjunction with the “module for” components of FIG. 8 also may correspond to similarly designated “means for” functionality. Thus, in some aspects one or more of such means may be implemented using one or more of processor components, integrated circuits, or other suitable structure as taught herein.
- [0071] Those of skill in the art will appreciate that information and signals may be represented using any of a variety of different technologies and techniques. For example, data, instructions, commands, information, signals, bits, symbols, and chips that may be referenced throughout the above description may be represented by voltages, currents, electromagnetic waves, magnetic fields or particles, optical fields or particles, or any combination thereof.
- [0072] Further, those of skill in the art will appreciate that the various illustrative logical blocks, modules, circuits, and algorithm steps described in connection with the aspects disclosed herein may be implemented as electronic hardware, computer software, or combinations of both. To clearly illustrate this interchangeability of hardware and software, various illustrative components, blocks, modules, circuits, and steps have been described above generally in terms of their functionality. Whether such functionality is implemented as hardware or software depends upon the particular application and design constraints imposed on the overall system. Skilled artisans may implement the described functionality in varying ways for each particular application, but such implementation decisions should not be interpreted as causing a departure from the scope of the present disclosure.
- [0073] The various illustrative logical blocks, modules, and circuits described in connection with the aspects disclosed herein may be implemented or performed with a general purpose processor, a DSP, an ASIC, an FPGA, or other programmable logic device, discrete gate or transistor logic, discrete hardware components, or any combination thereof designed to perform the functions described herein. A general purpose processor may be a microprocessor, but in the alternative, the processor may be any

conventional processor, controller, microcontroller, or state machine. A processor may also be implemented as a combination of computing devices, e.g., a combination of a DSP and a microprocessor, a plurality of microprocessors, one or more microprocessors in conjunction with a DSP core, or any other such configuration.

[0074] The methods, sequences and/or algorithms described in connection with the aspects disclosed herein may be embodied directly in hardware, in a software module executed by a processor, or in a combination of the two. A software module may reside in random access memory (RAM), flash memory, read-only memory (ROM), erasable programmable ROM (EPROM), electrically erasable programmable ROM (EEPROM), registers, hard disk, a removable disk, a CD-ROM, or any other form of storage medium known in the art. An exemplary storage medium is coupled to the processor such that the processor can read information from, and write information to, the storage medium. In the alternative, the storage medium may be integral to the processor. The processor and the storage medium may reside in an ASIC. The ASIC may reside in a user terminal (e.g., UE). In the alternative, the processor and the storage medium may reside as discrete components in a user terminal.

[0075] In one or more exemplary aspects, the functions described may be implemented in hardware, software, firmware, or any combination thereof. If implemented in software, the functions may be stored on or transmitted over as one or more instructions or code on a computer-readable medium. Computer-readable media includes both computer storage media and communication media including any medium that facilitates transfer of a computer program from one place to another. A storage media may be any available media that can be accessed by a computer. By way of example, and not limitation, such computer-readable media can comprise RAM, ROM, EEPROM, CD-ROM or other optical disk storage, magnetic disk storage or other magnetic storage devices, or any other medium that can be used to carry or store desired program code in the form of instructions or data structures and that can be accessed by a computer. Also, any connection is properly termed a computer-readable medium. For example, if the software is transmitted from a website, server, or other remote source using a coaxial cable, fiber optic cable, twisted pair, digital subscriber line (DSL), or wireless technologies such as infrared, radio, and microwave, then the coaxial cable, fiber optic cable, twisted pair, DSL, or wireless technologies such as infrared, radio, and microwave are included in the definition of medium. Disk and disc, as used herein,

includes compact disc (CD), laser disc, optical disc, digital versatile disc (DVD), floppy disk and Blu-ray disc where disks usually reproduce data magnetically, while discs reproduce data optically with lasers. Combinations of the above should also be included within the scope of computer-readable media.

[0076] While the foregoing disclosure shows illustrative aspects of the disclosure, it should be noted that various changes and modifications could be made herein without departing from the scope of the disclosure as defined by the appended claims. The functions, steps and/or actions of the method claims in accordance with the aspects of the disclosure described herein need not be performed in any particular order. Furthermore, although elements of the disclosure may be described or claimed in the singular, the plural is contemplated unless limitation to the singular is explicitly stated.

CLAIMS**WHAT IS CLAIMED IS:**

1. A method of operating a user equipment (UE), comprising:
transmitting one or more tracking area update (TAU) request messages while operating in accordance with Dual Connectivity for New Radio (DCNR) mode;
detecting that the DCNR mode is disabled; and
selectively triggering an Attach procedure that is configured to indicate that the DCNR mode is disabled in response to the detecting.
2. The method of claim 1, wherein, subsequent to the detecting, the Attach procedure is performed before any TAU request message is transmitted by the UE.
3. The method of claim 1, wherein the selectively triggering triggers the Attach procedure automatically based on the detecting.
4. The method of claim 1, further comprising:
obtaining a public land mobile network (PLMN) list that indicates PLMNs which are configured to reject TAU request messages that are transmitted after the DCNR mode is disabled; and
determining whether a current serving PLMN corresponds to one of the PLMNs indicated by the PLMN list,
wherein the selectively triggering triggers the Attach procedure if the current serving PLMN is determined to correspond to one of the PLMNs indicated by the PLMN list, and
wherein the selectively triggering does not trigger the Attach procedure if the current serving PLMN is not determined to correspond to one of the PLMNs indicated by the PLMN list.
5. The method of claim 4, wherein at least part of the PLMN list is obtained from an external source.

6. The method of claim 4, wherein the selectively triggering does not trigger the Attach procedure, further comprising:
 - transmitting a TAU request message after the detecting;
 - receiving a TAU reject message in response to the TAU request message transmitted after the detecting; and
 - adding a current serving PLMN to the PLMN list in response to the received TAU reject message.
7. The method of claim 4, further comprising:
 - resetting the PLMN list in response to a triggering event.
8. The method of claim 7, wherein the triggering event includes the UE powering off or a Subscriber Identity Module (SIM) card of the UE being removed.
9. A user equipment (UE), comprising:
 - means for transmitting one or more tracking area update (TAU) request messages while operating in accordance with Dual Connectivity for New Radio (DCNR) mode;
 - means for detecting that the DCNR mode is disabled; and
 - means for selectively triggering an Attach procedure that is configured to indicate that the DCNR mode is disabled in response to the detection.
10. The UE of claim 9, wherein, subsequent to the detection, the Attach procedure is performed before any TAU request message is transmitted by the UE.
11. The UE of claim 9, wherein the means for selectively triggering triggers the Attach procedure automatically based on the detection.
12. The UE of claim 9, further comprising:
 - means for obtaining a public land mobile network (PLMN) list that indicates PLMNs which are configured to reject TAU request messages that are transmitted after the DCNR mode is disabled; and

means for determining whether a current serving PLMN corresponds to one of the PLMNs indicated by the PLMN list,

wherein the means for selectively triggering triggers the Attach procedure if the current serving PLMN is determined to correspond to one of the PLMNs indicated by the PLMN list, and

wherein the means for selectively triggering does not trigger the Attach procedure if the current serving PLMN is not determined to correspond to one of the PLMNs indicated by the PLMN list.

13. The UE of claim 12, wherein at least part of the PLMN list is obtained from an external source.

14. The UE of claim 12, wherein the selectively triggering does not trigger the Attach procedure, further comprising:

means for transmitting a TAU request message after the detection;

means for receiving a TAU reject message in response to the TAU request message transmitted after the detection; and

means for adding a current serving PLMN to the PLMN list in response to the received TAU reject message.

15. The UE of claim 12, further comprising:

means for resetting the PLMN list in response to a triggering event.

16. The UE of claim 15, wherein the triggering event includes the UE powering off or a Subscriber Identity Module (SIM) card of the UE being removed.

17. A user equipment (UE), comprising:

a memory;

at least one communications interface; and

at least one processor communicatively coupled to the memory, the at least one communications interface, the at least one processor configured to:

transmit one or more tracking area update (TAU) request messages while operating in accordance with Dual Connectivity for New Radio (DCNR) mode;

detect that the DCNR mode is disabled; and
selectively trigger an Attach procedure that is configured to indicate that the DCNR mode is disabled in response to the detection.

18. The UE of claim 17, wherein, subsequent to the detection, the Attach procedure is performed before any TAU request message is transmitted by the UE.

19. The UE of claim 17, wherein the at least one processor is further configured to trigger the Attach procedure automatically based on the detection.

20. The UE of claim 17, wherein the at least one processor is further configured to:
obtain a public land mobile network (PLMN) list that indicates PLMNs which are configured to reject TAU request messages that are transmitted after the DCNR mode is disabled;

determine whether a current serving PLMN corresponds to one of the PLMNs indicated by the PLMN list;

trigger the Attach procedure if the current serving PLMN is determined to correspond to one of the PLMNs indicated by the PLMN list, and

not trigger the Attach procedure if the current serving PLMN is not determined to correspond to one of the PLMNs indicated by the PLMN list.

21. The UE of claim 20, wherein at least part of the PLMN list is obtained from an external source.

22. The UE of claim 20, wherein the at least one processor is further configured to:
not trigger the Attach procedure;

transmit a TAU request message after the detection;

receive a TAU reject message in response to the TAU request message transmitted after the detection; and

add a current serving PLMN to the PLMN list in response to the received TAU reject message.

23. The UE of claim 20, wherein the at least one processor is further configured to:

reset the PLMN list in response to a triggering event.

24. The UE of claim 23, wherein the triggering event includes the UE powering off or a Subscriber Identity Module (SIM) card of the UE being removed.

25. A non-transitory computer-readable medium containing instructions stored thereon, which, when executed by a user equipment (UE), cause the UE to perform operations, the instructions comprising:

at least one instruction to cause the UE to transmit one or more tracking area update (TAU) request messages while operating in accordance with Dual Connectivity for New Radio (DCNR) mode;

at least one instruction to cause the UE to detect that the DCNR mode is disabled; and

at least one instruction to cause the UE to selectively trigger an Attach procedure that is configured to indicate that the DCNR mode is disabled in response to the detection.

26. The non-transitory computer-readable medium of claim 25, wherein, subsequent to the detection, the Attach procedure is performed before any TAU request message is transmitted by the UE.

27. The non-transitory computer-readable medium of claim 25, wherein the at least one instruction to cause the UE to selectively trigger causes the UE to trigger the Attach procedure automatically based on the detection.

28. The non-transitory computer-readable medium of claim 25, further comprising:

at least one instruction to cause the UE to obtain a public land mobile network (PLMN) list that indicates PLMNs which are configured to reject TAU request messages that are transmitted after the DCNR mode is disabled;

at least one instruction to cause the UE to determine whether a current serving PLMN corresponds to one of the PLMNs indicated by the PLMN list;

wherein the at least one instruction to cause the UE to selectively trigger causes the UE to trigger the Attach procedure if the current serving PLMN is determined to correspond to one of the PLMNs indicated by the PLMN list, and

wherein the at least one instruction to cause the UE to selectively trigger causes the UE to not trigger the Attach procedure if the current serving PLMN is not determined to correspond to one of the PLMNs indicated by the PLMN list.

29. The non-transitory computer-readable medium of claim 28, wherein at least part of the PLMN list is obtained from an external source.

30. The non-transitory computer-readable medium of claim 28, wherein the at least one instruction to cause the UE to selectively trigger causes the UE to not trigger the Attach procedure, further comprising:

at least one instruction to cause the UE to transmit a TAU request message after the detection;

at least one instruction to cause the UE to receive a TAU reject message in response to the TAU request message transmitted after the detection; and

at least one instruction to cause the UE to add a current serving PLMN to the PLMN list in response to the received TAU reject message.

31. The non-transitory computer-readable medium of claim 28, further comprising:

at least one instruction to cause the UE to reset the PLMN list in response to a triggering event.

32. The non-transitory computer-readable medium of claim 31, wherein the triggering event includes the UE powering off or a Subscriber Identity Module (SIM) card of the UE being removed.

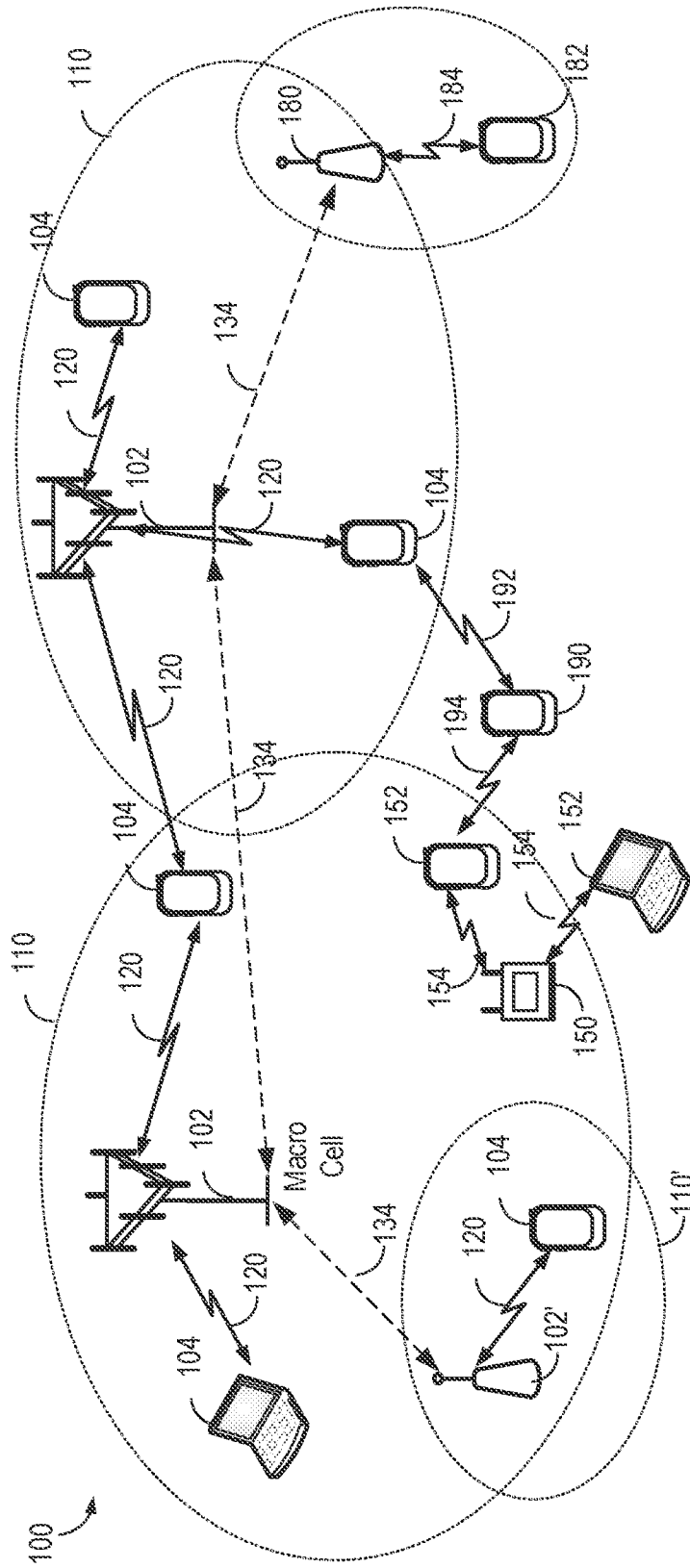

FIG. 1

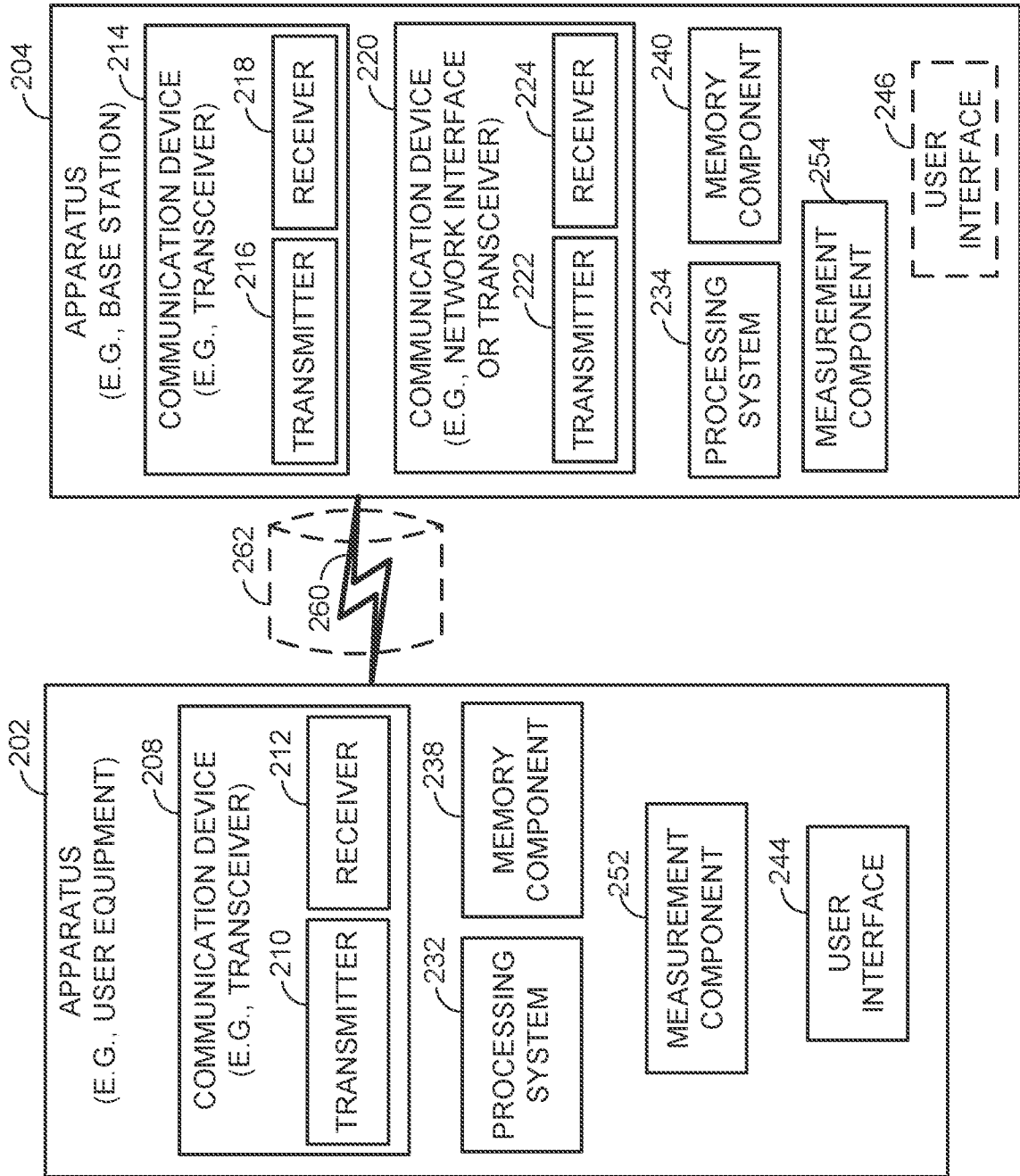

FIG. 2

300 ↘

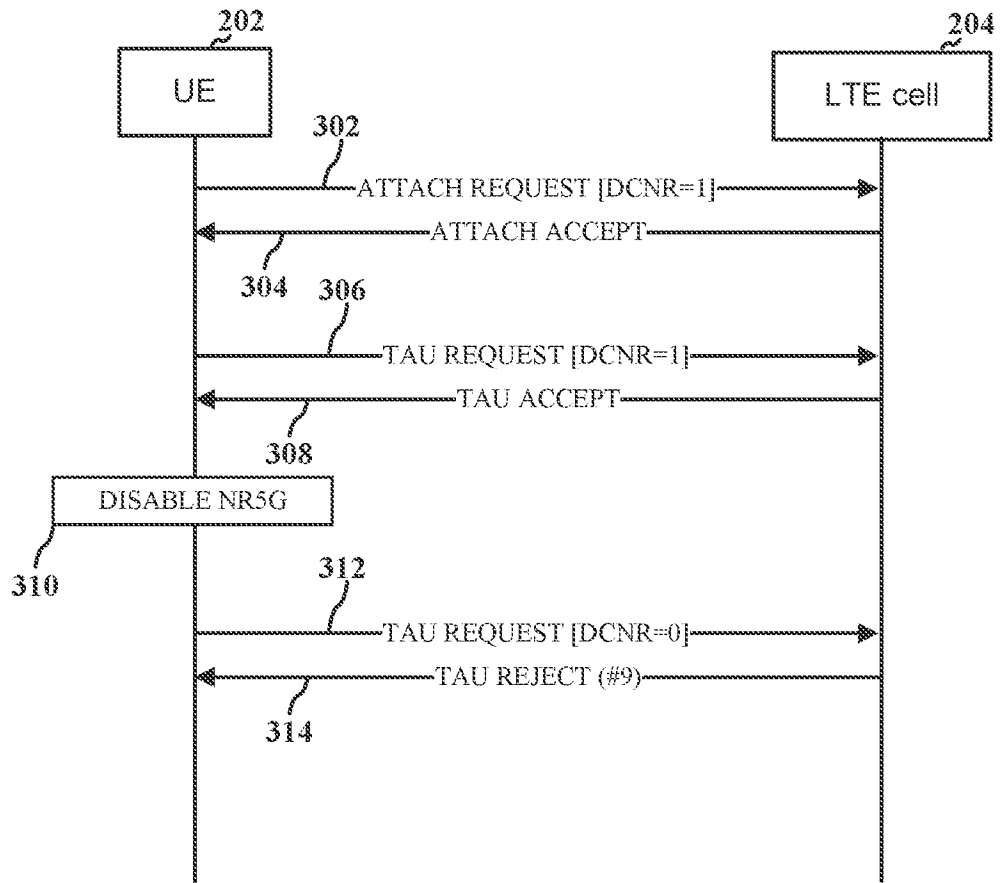

FIG. 3

4/8

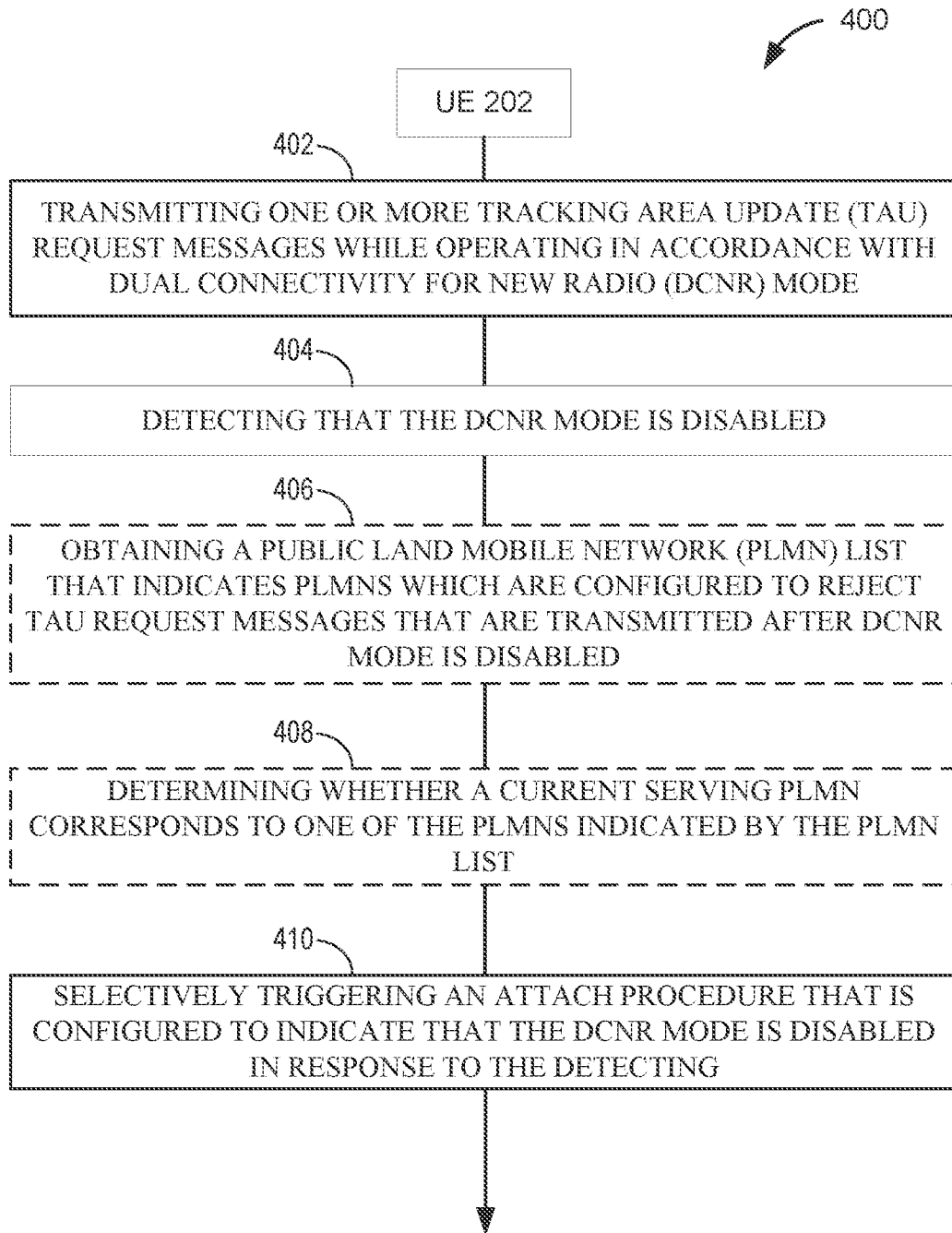

FIG. 4

500 ↘

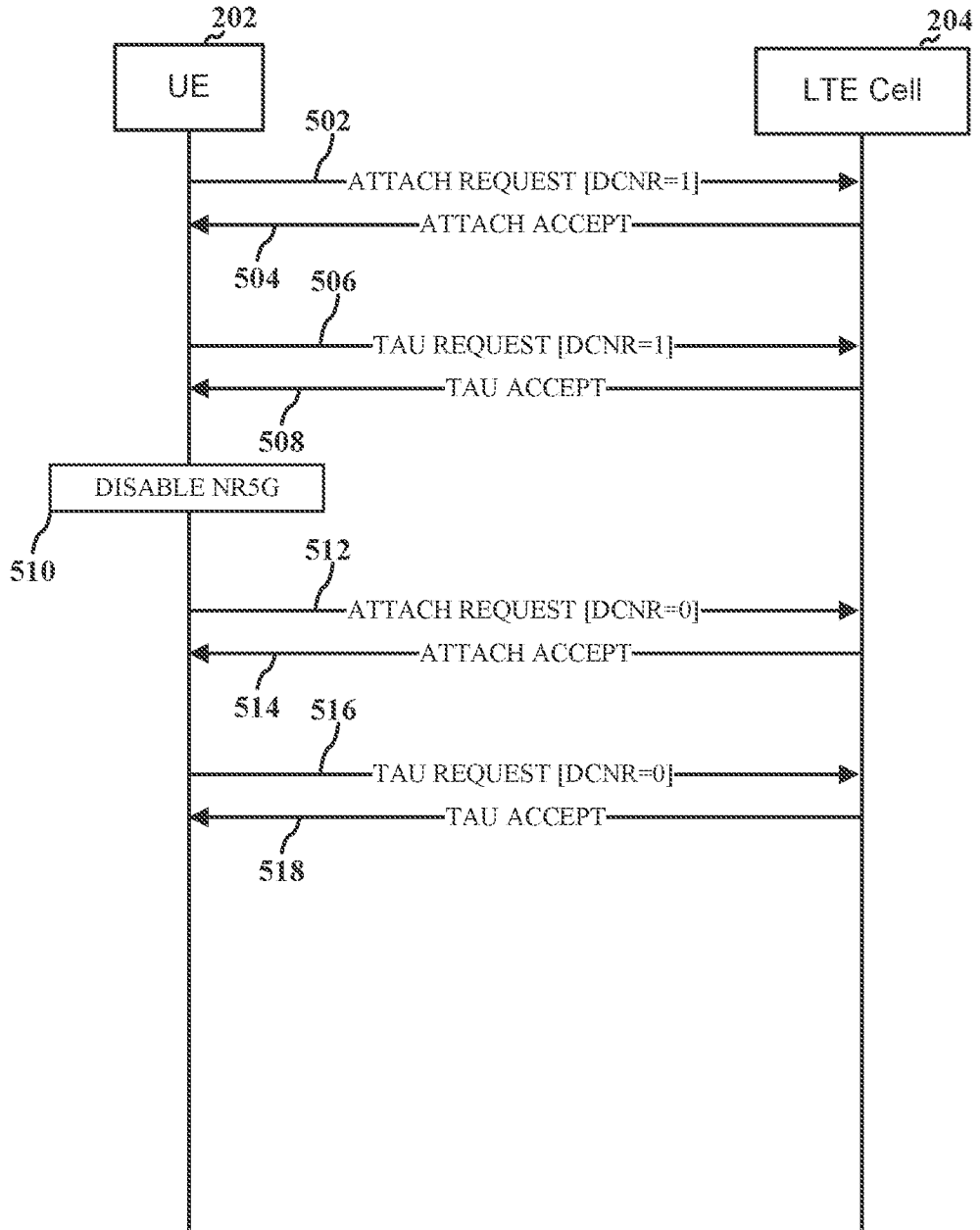

FIG. 5

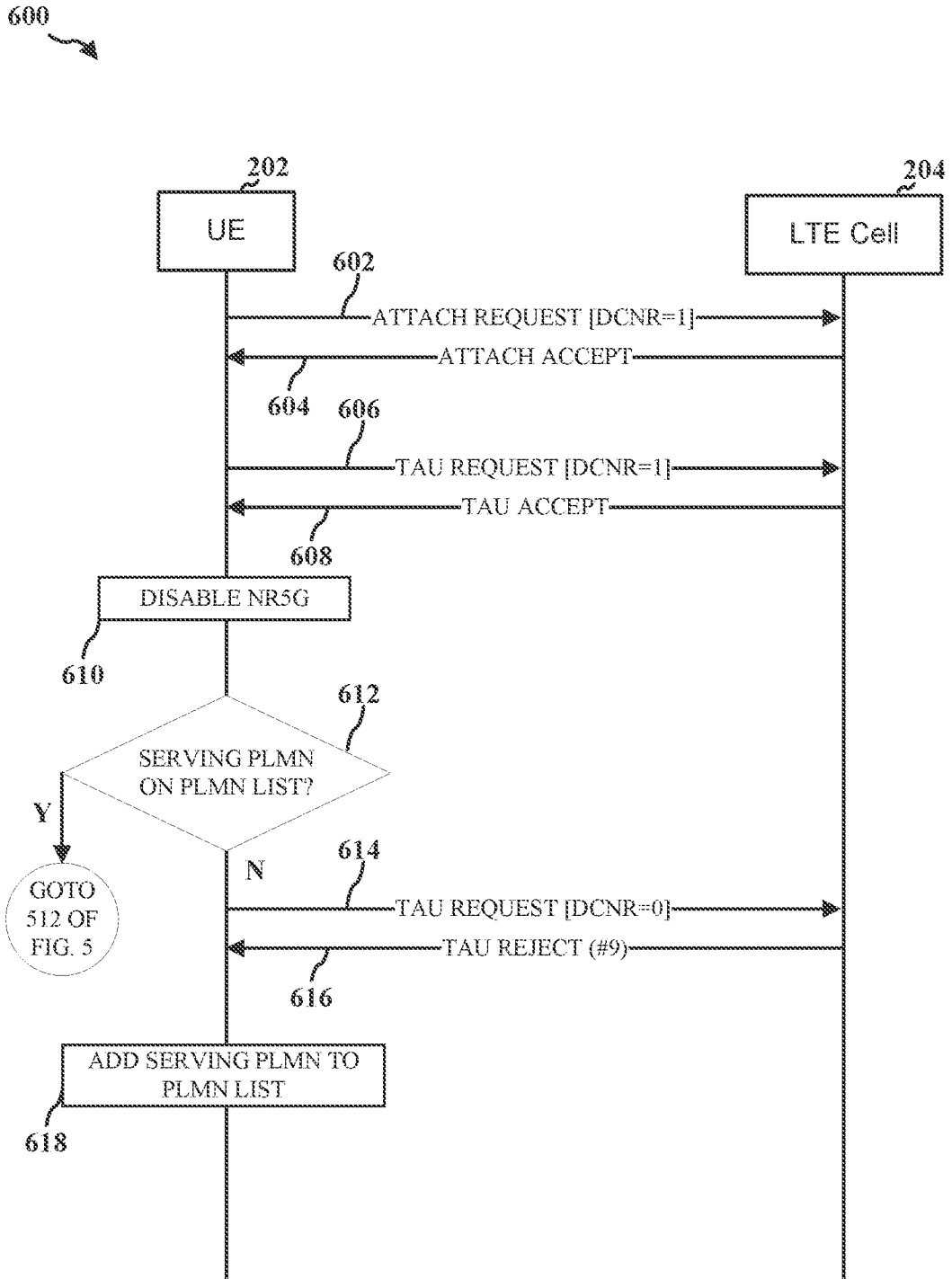

FIG. 6

7/8

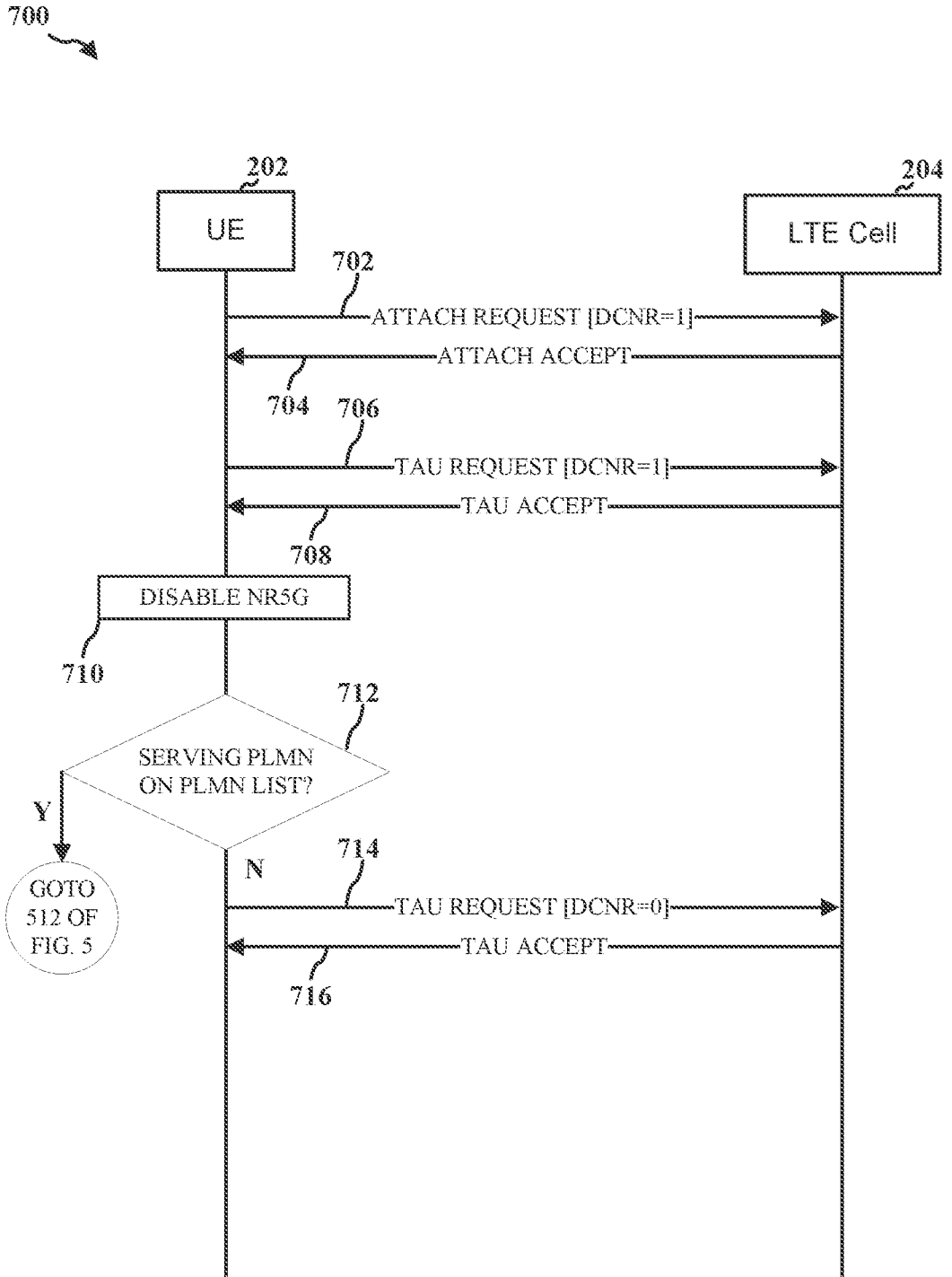

FIG. 7

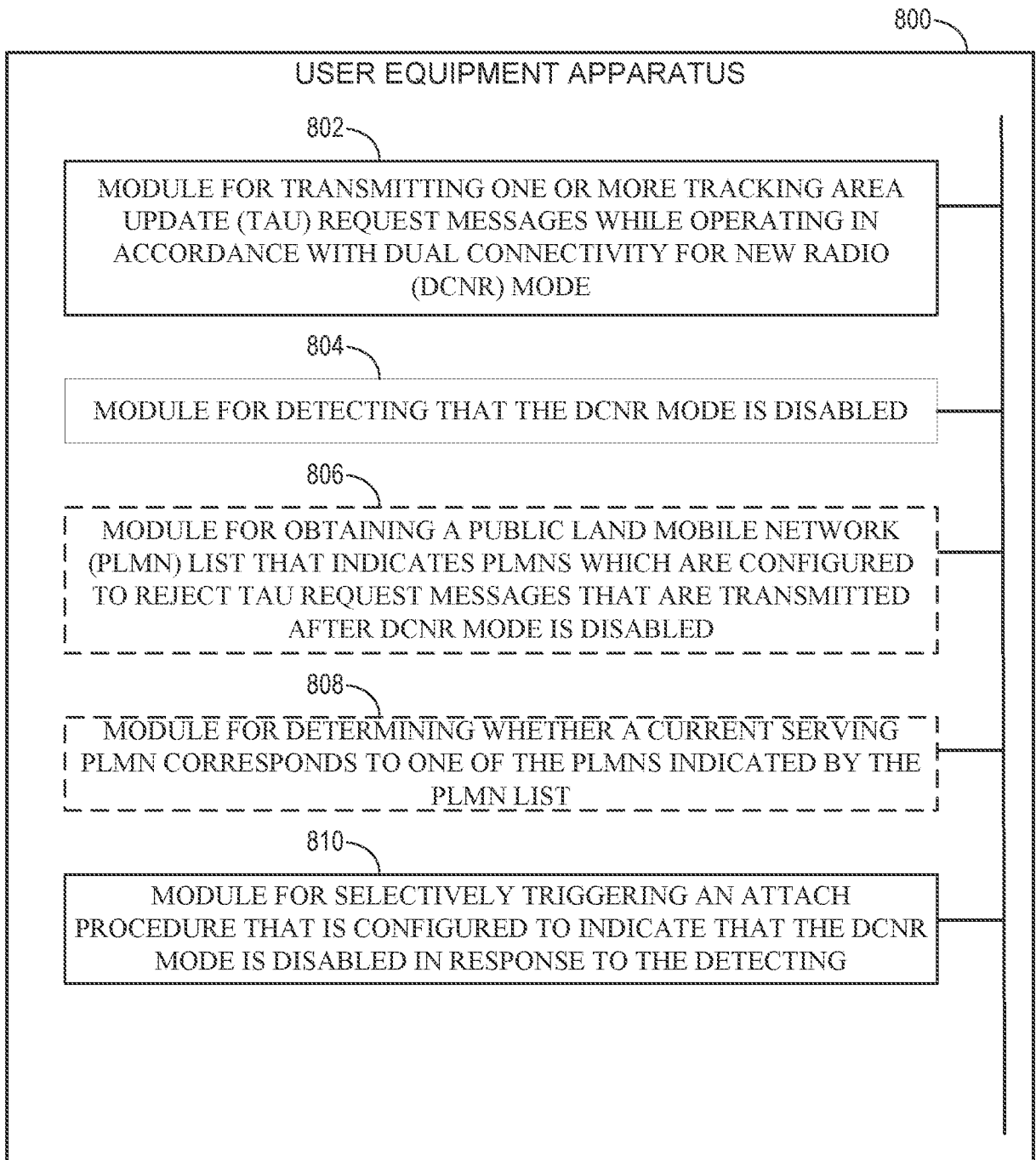

FIG. 8

INTERNATIONAL SEARCH REPORT

International application No.

PCT/CN2020/092005

A. CLASSIFICATION OF SUBJECT MATTER		
H04W 76/27(2018.01)i; H04W 88/06(2009.01)i; H04W 36/28(2009.01)i; H04W 48/08(2009.01)i; H04W 48/16(2009.01)i		
According to International Patent Classification (IPC) or to both national classification and IPC		
B. FIELDS SEARCHED		
Minimum documentation searched (classification system followed by classification symbols) H04W H04L H04B		
Documentation searched other than minimum documentation to the extent that such documents are included in the fields searched		
Electronic data base consulted during the international search (name of data base and, where practicable, search terms used) DWPI;SIPOABS;CNABS;CNTXT;CNKI;USTXT;EPTXT;WOTXT;3GPP:tracking area update, dual connectivity, attach+, disabl+,TAU, DCNR		
C. DOCUMENTS CONSIDERED TO BE RELEVANT		
Category*	Citation of document, with indication, where appropriate, of the relevant passages	Relevant to claim No.
Y	US 2020037387 A1 (SAMSUNG ELECTRONICS CO., LTD.) 30 January 2020 (2020-01-30) description, paragraphs [0292]-[0408] and figures 1-33	1-32
Y	CN 110022587 A (VIVO MOBILE COMMUNICATION CO., LTD.) 16 July 2019 (2019-07-16) description, paragraphs [0047]-[0072] and figures 1-17	1-32
A	CN 108282827 A (BEIJING SAMSUNG COMMUNICATION TECHNOLOGY et al.) 13 July 2018 (2018-07-13) the whole document	1-32
<input type="checkbox"/> Further documents are listed in the continuation of Box C. <input checked="" type="checkbox"/> See patent family annex.		
* Special categories of cited documents: "A" document defining the general state of the art which is not considered to be of particular relevance "E" earlier application or patent but published on or after the international filing date "L" document which may throw doubts on priority claim(s) or which is cited to establish the publication date of another citation or other special reason (as specified) "O" document referring to an oral disclosure, use, exhibition or other means "P" document published prior to the international filing date but later than the priority date claimed "T" later document published after the international filing date or priority date and not in conflict with the application but cited to understand the principle or theory underlying the invention "X" document of particular relevance; the claimed invention cannot be considered novel or cannot be considered to involve an inventive step when the document is taken alone "Y" document of particular relevance; the claimed invention cannot be considered to involve an inventive step when the document is combined with one or more other such documents, such combination being obvious to a person skilled in the art "&" document member of the same patent family		
Date of the actual completion of the international search 07 February 2021		Date of mailing of the international search report 19 February 2021
Name and mailing address of the ISA/CN National Intellectual Property Administration, PRC 6, Xitucheng Rd., Jimen Bridge, Haidian District, Beijing 100088 China Facsimile No. (86-10)62019451		Authorized officer LIU,Xin Telephone No. 86-010-62412157

INTERNATIONAL SEARCH REPORT
Information on patent family members

International application No. PCT/CN2020/092005

Patent document cited in search report			Publication date (day/month/year)	Patent family member(s)			Publication date (day/month/year)
US	2020037387	A1	30 January 2020	US	2020351976	A1	05 November 2020
				CN	110784897	A	11 February 2020
				EP	3599787	A1	29 January 2020
				WO	2020022762	A1	30 January 2020

CN	110022587	A	16 July 2019	WO	2019137367	A1	18 July 2019

CN	108282827	A	13 July 2018	None			
