



(12) EUROPEAN PATENT APPLICATION

(43) Date of publication:
29.11.2006 Bulletin 2006/48

(51) Int Cl.:
D06F 39/12 (2006.01)

(21) Application number: 06116865.4

(22) Date of filing: 26.03.2004

(84) Designated Contracting States:
AT BE BG CH CY CZ DE DK EE ES FI FR GB GR
HU IE IT LI LU MC NL PL PT RO SE SI SK TR

(72) Inventor: **Bongini, Dino**
24125 Bergamo (IT)

(30) Priority: 28.03.2003 IT TO20030236

(74) Representative: **Gallarotti, Franco**
Buzzi, Notaro & Antonielli d'Oulx Srl,
Via Maria Vittoria, 18
10123 Torino (IT)

(62) Document number(s) of the earlier application(s) in
accordance with Art. 76 EPC:
04007302.5 / 1 462 562

Remarks:

This application was filed on 07 - 07 - 2006 as a
divisional application to the application mentioned
under INID code 62.

(71) Applicant: **Indesit Company S.p.A.**
60044 Fabriano (AN) (IT)

(54) **A laundry washing and/or drying machine, in particular of the front loading type, with lower housing**

(57) A laundry washing and/or drying machine (1) has a cabinet (2) inferiorly delimited by a respective bottom (F) in which a recess (17) is formed. The recess (17) is open towards the exterior of the cabinet (2) in two directions, substantially orthogonal to each other (X, Y). To the bottom can be fastened a lower base (20) defining a respective cavity (21), in such a way that the recess (17) of the bottom of the cabinet (2) and the cavity (21) of the base (20) directly communicate with each other, to form a seat for housing a container.

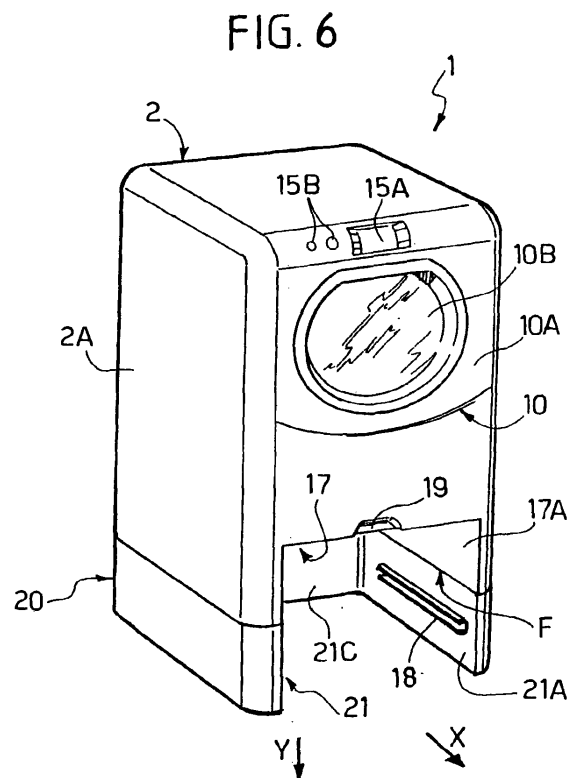

Description

[0001] The present invention relates to a laundry washing and/or drying machine, in particular of the front loading type, having a cabinet which is delimited inferiorly by a respective bottom, in the cabinet being defined a space within which a tub is located, in the latter being housed a drum capable of rotating around a respective axis.

[0002] It is well known that laundry washers presuppose the use of washing agents, for instance in the form of powdered or liquid detergents, bleaches, softeners, etcetera. In some case, the aforesaid washing agents must be preventively dosed prior to their placement in the machine, by means of appropriate dosing cups; in other cases, the quantity of detergent needed to complete a wash cycle is placed in a hollow spherical container, which is then positioned directly inside the drum of the machine, among the laundry to be washed. The containers of the various washing agents, be they in the form of bottles, boxes, pouches, etcetera, and/or the aforesaid dosing devices or spherical containers should opportunely be stored near the machine, for obvious reasons of convenience of use.

[0003] Bases or pedestals have been proposed, with the aim of raising the cabinet of a laundry washing machine relative to the ground and thereby facilitate, from the viewpoint of ergonomics, the operations of loading/unloading the laundry relative to the machine; in some case, within the base a housing is defined for a container or a drawer, in which objects of various nature can be stowed; examples of bases of this kind are found, for instance, in DE-A-19 83 8630 and EP-A-1 205 129.

[0004] Additionally, the document US-A-2,786,730 discloses a laundry washing machine with a cabinet in whose front wall a door is present, in addition to the one normally provided to allow loading and unloading the laundry; the additional door is mounted in an opening of the front wall, which allows to access an inner compartment of the cabinet, in which various kinds of products and objects can be stowed.

[0005] In view of the aforementioned state of the art, an aim of the present invention is to provide a laundry washing and/or drying machine of simple and economical construction and ease of use, whose structure allows to define a compartment within which various kinds of objects can be stowed. A further aim of the invention is to provide an additional base whose use is particularly advantageous in combination with the aforesaid laundry washing machine.

[0006] These and other aims are achieved, according to the present invention, by a laundry washing and/or drying machine having the characteristics of the appended claims, which are an integral part of the present description.

[0007] Additional aims, characteristics and advantages of the present invention shall become readily apparent from the detailed description that follows and from the accompanying drawings, provided purely by way of ex-

planatory and non limiting example, in which:

- Figure 1 is a schematic perspective view of a front loading laundry washing machine according to the invention, in a first configuration of use;
- Figure 2 is a schematic perspective view of the machine of Figure 1, with a respective container removed;
- Figure 3 is a partially sectioned schematic lateral view of the machine of Figure 2;
- Figure 4 is a schematic section view according to the line IV-IV of Figure 3;
- Figure 5 is a schematic perspective view of a front loading laundry washing machine according to the invention, in a second configuration of use;
- Figure 6 is a schematic perspective view of the machine of Figure 5, with a respective container removed;
- Figure 7 is a partially sectioned schematic lateral view of the machine of Figure 6;
- Figure 8 is a schematic section view according to the line VIII-VIII of Figure 7.

[0008] In the figures, the reference number 1 globally designates a front loading laundry washing machine according to the invention. The machine 1 comprises a cabinet 2, for instance made of metal plate, which delimits a substantially closed space S, for housing functional members of the machine. Within the space S a so called oscillating assembly is mounted, comprising a washing tub 3, in which a drum for the laundry is housed, designated by the number 4 in Figure 3, able to rotate around a respective axis. In the exemplified case, the tub 3 is mounted in such a way the axis of rotation of the drum 4, designated as A, is slightly inclined; the machine 1 could in any case be of the traditional type, i.e. with the drum rotating according to a horizontal axis. As shown in Figure 3, the aforesaid oscillating assembly further comprises an electrical motor 5, fastened inferiorly to the tub 3, in the rear area thereof; as in the prior art, the actuation produced by the shaft of the motor 5 is transmitted to the drum 4 through a belt and a pulley, not shown.

[0009] The oscillating assembly further comprises a first and a second counterweight, designated respectively as 6 and 7 in Figure 3, which develop lengthwise substantially in a circumference arc; the counterweight 6 is fastened superiorly to the tub 3, in the rear area thereof, whilst the counterweight 7 is fastened inferiorly to the tub, in the front area thereof. The oscillating assembly is supported from below by means of four load-bearing feet 8, i.e. elements that integrate within them both a spring and a braking element; each foot 8 has a lower end, anchored to a respective support 8A integral with the lower bottom of the cabinet 2, and an upper end anchored to the tub 3. Alternatively, the load-bearing feet 8 could be replaced with classic damping elements, in the form of friction dampers, with the tub assembly hung superiorly to two

springs anchored at one end to the tub 3 and at the other end to respective attachments of the cabinet 2; Figure 1 shows a possible position of such possible springs, designated by the number 9. The dampers 8, and the springs if any, are inclined relative to the vertical, to converge from the respective attachment point to the cabinet 2 or to the support 8A towards the tub 3.

[0010] The cabinet 2 has a front opening, whereat a door is positioned, designated by the number 10 in Figures 1 and 2, comprising a respective frame 10A and a transparent central part 10B, for instance made of glass. The door 10 is provided with means for hinging to the cabinet 2 and with a locking/releasing mechanism, which elements are not shown. The opening of the cabinet 2 in which the door 10 is operative faces a homologous opening present in the front wall of the tub 3; the latter in turn faces a corresponding opening defined in the front part of the drum 4; between the front wall of the cabinet 2 and the opening of the tub 3 suitable sealing means are provided, constituted for instance by a bellows gasket 11 having substantially annular and/or tapered shape, with ends in correspondence with the opening of the drum 4.

[0011] Within the space S delimited by the walls of the cabinet 2 a dispenser of washing agents 12 is also provided, which can be fed with water. The dispenser 12 is positioned in proximity to the lower edge of the opening present in the front wall of the cabinet 2 and is fastened thereto; the dispenser 12 is thus positioned within the annular space delimited by the gasket 11; in this way the water - washing agent mixture released by the dispenser 12 can arrive directly and quickly in contact with the laundry to be washed, guided by the gasket 11 which extends between the opening of the cabinet 2 and the mouth of the drum 4.

[0012] On the lower bottom of the cabinet 2 a discharge pump 13 and a sensor 14 of an anti-flooding safety device are present, known in themselves and shown schematically herein. Other usual functional components of the machine 1 internal to the space S, such a filter, a programmer, hydraulic conduits, electrical cables, etcetera are not shown in the figures. The references 15A and 15B designate an information display and some control push-buttons of the machine 1, which can be mounted on the frame 10A of the door 10 or on the cabinet 2. To the bottom of the cabinet 2, lastly, height-adjustable support feet P are associated, for instance of the type with threaded stem screwed in a respective nut screw present in the bottom itself.

[0013] The reference number 16 globally designates a container which, in the exemplified case, is in the form of a drawer, having a respective front wall 16A, suitable to house various kinds of objects, such as packages of washing agents, dosing cups, rags, etcetera. As shown in Figure 2, where the drawer 16 is removed, the bottom of the cabinet 2 is so shaped as to have a niche or recess 17 open towards the exterior of the cabinet in two directions, substantially orthogonal to each other, designated by the references X and Y in Figures 2 and 3; within the

recess 17 at least part of the drawer 16 can be housed. The recess 17 is delimited by outer surfaces of walls which are part of the bottom of the cabinet 2 as a whole, so that, in fact, the drawer 16 is positioned outside the space S. In the exemplified case, the recess 17 is delimited by two opposite vertical walls 17A, an upper wall 17B and a rear wall 17C of the bottom. The recess 17 is thus completely open on two substantially orthogonal faces of the cabinet 2, an in particular the front and lower faces.

[0014] In the preferred embodiment of the invention, the lower bottom of the cabinet 2 is formed by a single component made of plastic material, such as polypropylene with the addition of structural inert charge, designated by the reference F in Figures 2, 3 and 4, whereto are fastened in known manners (for example by means of screws) distinct panels which form the vertical walls of the cabinet 2. Said plastic bottom can advantageously integrate the supports 8A and other anchoring/support elements for inner components of the machine 2, such as the pump 13 and the sensor 14. In a possible, though less advantageous, variation, one or more walls 17A, 17B and 17C could be obtained by suitably bending a respective panel which forms a vertical wall of the cabinet 2, with the contiguous edges of the walls belonging to different panels being welded or saddle joined to each other, in known manners. On the outer surface of each of the walls 17A a respective guide 18 can be provided for the extraction of the drawer 16; note that the presence of the guides 18 is merely optional, since the container 16 could bear directly on the floor and be in the form of a trolley, movable on lower wheels.

[0015] When the drawer 16 is housed in the recess 17, as in Figure 1, the front wall 16A of the drawer 16 is substantially flush with the front wall of the cabinet 2; in said front wall is conveniently formed a depression 19 in correspondence with the upper edge of the recess 17, to allow an easy grip on the front wall 16A of the drawer 16.

[0016] As shown in Figures 3 and 4, between the wall 17C which posteriorly delimits the recess 17 and the rear wall of the cabinet or of the bottom F, designated by the reference F1, a portion of the space S extends, in which the pump 13 and the sensor 14 are positioned; between the walls 17A which laterally delimit the recess 17 and the respective lateral walls 2A of the cabinet 2 or of the bottom F, designated by the reference F2, two parallel portions of the space S are defined, in which the front dampers 8 and the respective supports extend. Figure 3 also shows that the wall 17B which superiorly delimits the recess 17 is slightly inclined towards the rear part of the cabinet 2. This arrangement allows to convey any water leaks towards the sensor 14, so the latter can detect them rapidly and consequently can inhibit any further inflow of water into the machine and/or the power supply to the machine, in manners that are known in themselves.

[0017] To improve the ergonomics of the machine 1 according to the invention, a respective pedestal or base can be associated to the machine, designated in Figures

5 through 8 by the reference 20, for instance made of metallic material. As shown in Figures 6 and 8, the base-ment 20 has a box structure with substantially C shaped section, so that a respective cavity 21 is formed within it, open to the front, open upwards, towards the overlying machine 1 and open downwards, i.e. towards the floor. The aforesaid cavity 21 is delimited by two opposite lateral walls 21A and a rear wall 21C of the base.

[0018] The machine is fastened on the base 20 with known means, for instance by means of screws, after removing from the cabinet 2 the respective lower feet P; the latter can advantageously be transferred to the base 20, whose bottom wall shall be provided with respective nut screws; alternatively, the base 20 can be provided with its own feet with adjustable height.

[0019] As shown in Figure 6, as a result of the superposition of the cabinet 2 onto the base 20, the recess 17 overlies the cavity 21, in such a way as to form a suitable seat to house a movable container, designated by the number 22 in Figure 5, having greater dimensions than the container previously designated by the reference 16, and in particular having a containment volume that is substantially equal to that of the drum 4 of the machine 1. In view of the above, the container 22 can advantageously be used to store the laundry to be washed in the machine 1.

[0020] The container 22 can also be in the form of a drawer with respective front wall 22A suitable to remain substantially flush with the front surface of the cabinet 2; the base 20 also preferably has such external dimensions as to remain substantially flushed relative to the walls of the cabinet 2, when the cabinet is superposed to the base.

[0021] As shown in Figure 6, on the opposite walls 21A of the base 20 the guides 18 can be present for the drawer or container 22; advantageously, for this application, the guides 18 are removable from the machine 1 to be transferred on the base 20, in known fashion. In this case, too, the guides 18 are to be considered optional, since the container 22 could be in the form of a movable trolley on wheels that bear directly on the floor.

[0022] As shown in Figure 8, the width of the cavity 21, i.e. the distance between the respective walls 22A, is substantially equal to the width of the recess 17, whilst the lengthwise development of the cavity 21 is greater than that of the recess 17, as shown in Figure 6; for this reason, the container 22 can comprise an upper section 22', able to occupy the recess 17 of the cabinet 2, and a longer lower section 22", able to occupy the cavity 21 of the base 20.

[0023] Clearly, numerous variations are possible to the laundry washing machine and to the basement described herein by way of example, without thereby departing from the innovative scope inherent in the inventive idea, and it is clear that in the practical embodiment of the invention, shapes, dimensions, materials and components used may be different from those indicated previously by way of example, and replaced with technically equivalent el-

ements.

[0024] The complex formed by the machine 1 and by the base 20 could comprise two distinct containers; in this case, one container, particularly of the type in the form of a drawer able to slide on guides, would be housed in the recess 17, whilst the second container, in the form of a drawer or trolley, would be housed in the cavity 21.

[0025] To the front wall of the cabinet 2 a specific door could be associated, to close the recess 17 frontally; in the same way, to the base 20 its own door could be hinged, able to close frontally both the cavity 21 and the recess 17.

[0026] The basement could incorporate a trolley device of a known kind, as per a previous patent application by the Applicant, provided to facilitate the displacement of the assembly constituted by the basement and by the machine 1; such a device associated to the basement could comprise wheels or rollers and a respective mechanism for moving said wheels or rollers from an inoperative position, in which they are retracted, to an operative position, in which the wheels are lowered to raise the basement from the floor and thereby enable it to be moved easily.

Claims

1. Laundry washing and/or drying machine (1), in particular of the front loading type, comprising a cabinet (2) having a respective lower bottom (F), in the cabinet (2) a space (S) being defined within which a tub (3) is located housing a drum (4) capable of rotating around a respective axis (A), **characterised in that** in the bottom (F) a recess (17) is formed, open towards the exterior of the cabinet (2) in two directions substantially orthogonal to each other (X, Y) and able to house at least part of a container (16, 22) and **in that** the cabinet (2) is able to be fastened above a base (20) defining a respective cavity (21) open towards the exterior of the base (20) in at least two direction, substantially orthogonal to each other (X, Y), in such a way that the recess (17) of the bottom (F) and the cavity (21) of the base (20) directly communicate with each other.
2. A machine as claimed in claim 1, **characterised in that** the recess (17) extends between the bottom (F) and a front face of the cabinet.
3. A machine as claimed in claim 1, **characterised in that** the recess (17) is delimited by surfaces of the bottom (F) that face towards the exterior of the cabinet (2), where in particular the recess (17):
 - is laterally delimited by two respective opposite surfaces (17A) both belonging to the bottom (F), and/or
 - is delimited by a respective upper surface (17B)

and a respective rear surface (17C) belonging to the bottom (F).

4. A machine as claimed in claim 3, characterised in that

- the bottom comprises a component made of plastic material (F), in particular polypropylene, where to one or more of said surfaces (17A, 17B, 17C) belong, and/or
- at least one of said surfaces (17A, 17B, 17C) belongs to a wall element which also forms a lateral face of the cabinet (2).

5. A machine as claimed in claim 1, characterised in that at least the portion of the bottom (F) in which the recess (17) is defined is part of a component made of plastic material (F), in particular polypropylene.

6. A machine as claimed in claim 1, characterised in that an upper counterweight (6), a lower counterweight (7) and a motor (5) are associated to the tub (3), where in particular

- the upper counterweight (6) is positioned in the rear area of the tub (3),
- the lower counterweight (7) is positioned in the front area of the tub (3),
- the motor (5) is positioned inferiorly to the tub (3) in the rear area thereof,
- the tub (3) is supported by means of damper elements (8, 8A) connected to the bottom (F), the recess (17) extending between at least a pair of said damper elements (8, 8A).

7. A machine as claimed in claim 1, characterised in that the container (22) comprises a first portion (22') provided to be housed in the recess (17) of the bottom (F) and a second portion (22'') provided to be housed in the cavity (21) of the base (20).

8. A machine as claimed in claim 1, characterised in that on opposite surfaces (17A, 22A) of at least one between the recess (17) of the bottom (F) and the cavity (21) of the base (22) guiding means (18) are associated for the sliding of the container (16, 22), said container being substantially drawer shaped.

9. A machine as claimed in claim 1, characterised in that the container (16, 22) is movable on lower wheels.

10. A machine as claimed in claim 1, characterised in that the base (20) comprises a trolley system to facilitate the displacement of the assembly constituted by the base itself and by the machine (1), the system comprising wheels or the like, capable of assuming

an inoperative position, in which the wheels are retracted, and an operative position, in which the wheels are lowered to raise the base (20) from the ground.

11. A base for a laundry washing and/or drying machine, having a body (20) defining a cavity (21) open towards the exterior of the base (20) in at least two directions substantially orthogonal to each other (X, Y), for use in combination with a laundry washing and/or drying machine (1), as claimed in one or more of the previous claims.

12. An operative assembly formed by a lower base (20) whereon a laundry washing and/or drying machine (1) is fastened, in particular of the front loading type, the machine (1) having a cabinet (2) with a lower bottom (F) where to the base (20) is fastened, in the cabinet (2) a space (S) being defined within which a tub (3) is located, housing a drum (4) capable of rotating around a respective axis (A), **characterised in that** the cabinet (2) and the base (20) define respective portions (17, 22) of a seat for housing a same container (22), the latter comprising a first portion (22'), provided to be housed in the portion of seat (17) defined in the cabinet (2), and a second portion (22'') provided to be housed in the portion of seat (2) of the base (20).

FIG. 2

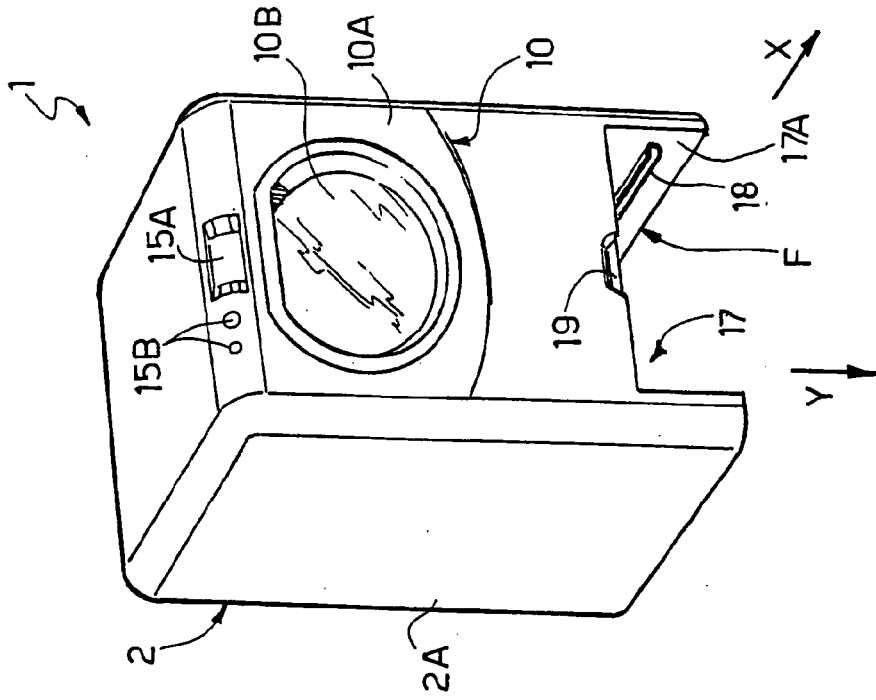

FIG. 1

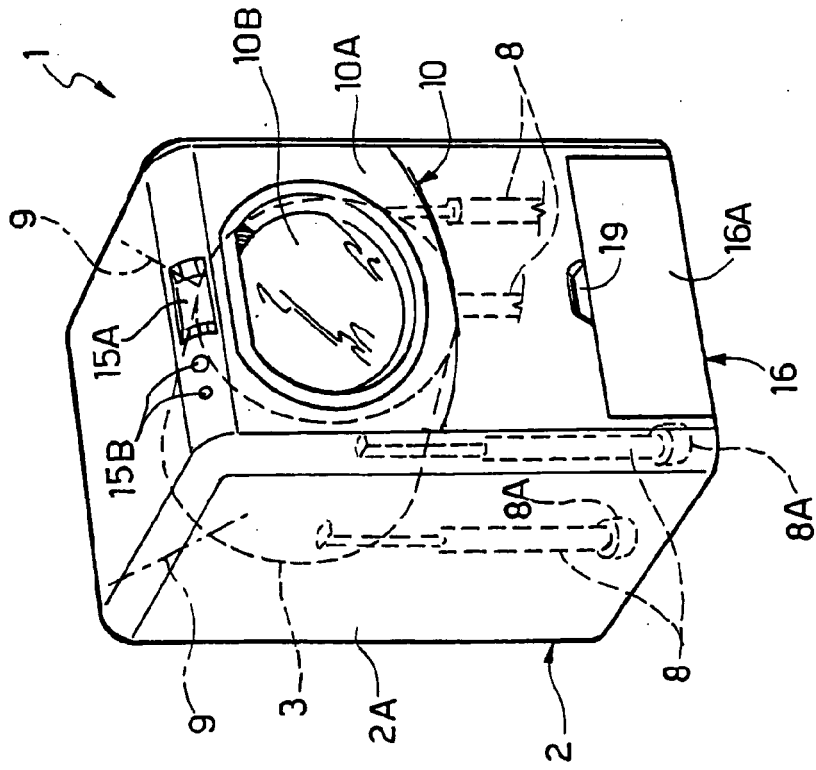

FIG. 3

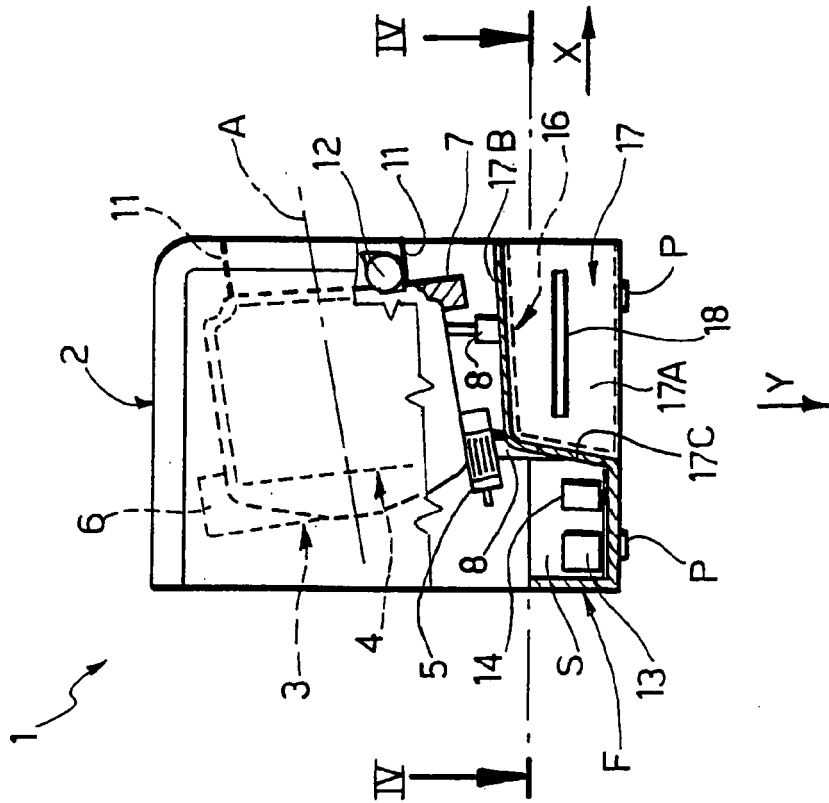

FIG. 4

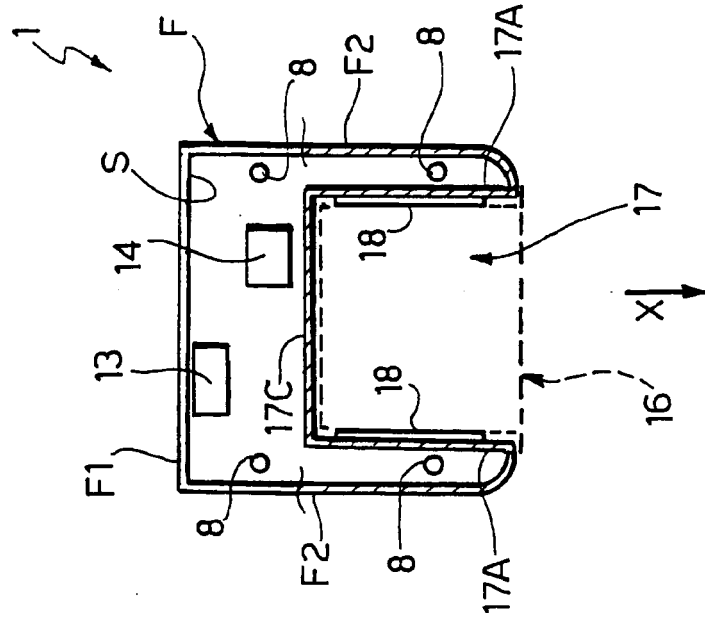

FIG. 6

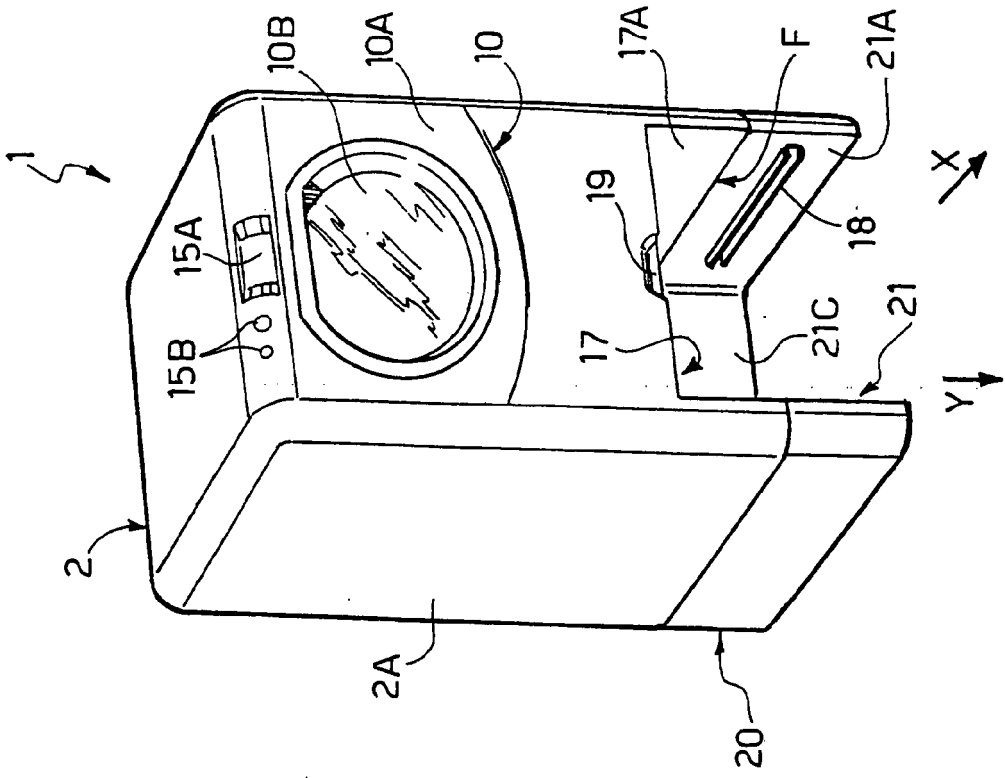
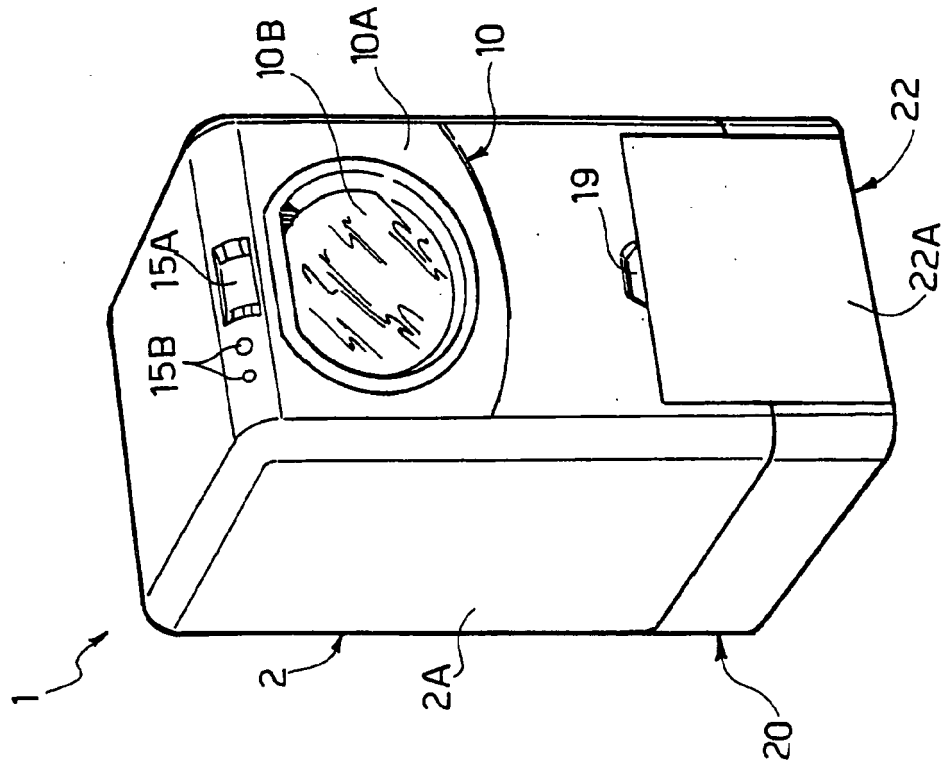

FIG. 5





DOCUMENTS CONSIDERED TO BE RELEVANT			
Category	Citation of document with indication, where appropriate, of relevant passages	Relevant to claim	CLASSIFICATION OF THE APPLICATION (IPC)
A	DE 32 12 527 A (LEPPER WILHELM DR ING) 13 October 1983 (1983-10-13) * the whole document, figure B *	1-3,7,8, 11,12	INV. D06F39/12
A	DE 94 19 048 U (FRAGARIA EZIO) 16 March 1995 (1995-03-16) * page 1, line 1 - page 4, line 12 * * figures 1,2,5 *	1-3,7-12	
A	EP 1 233 100 A (CANDY SPA) 21 August 2002 (2002-08-21) * paragraphs [0007] - [0013] * * figures 1-4 *	1-3,6, 11,12	
P,A	DE 203 02 572 U (HANSEN NIKOLAUS) 24 April 2003 (2003-04-24) * page 3, lines 16-27 * * page 4, line 11 - page 5, line 32 * * figures 1-5 *	1-5,7,8, 11,12	
The present search report has been drawn up for all claims			TECHNICAL FIELDS SEARCHED (IPC) D06F
Place of search Munich		Date of completion of the search 7 September 2006	Examiner Weinberg, Ekkehard
CATEGORY OF CITED DOCUMENTS X : particularly relevant if taken alone Y : particularly relevant if combined with another document of the same category A : technological background O : non-written disclosure P : intermediate document T : theory or principle underlying the invention E : earlier patent document, but published on, or after the filing date D : document cited in the application L : document cited for other reasons & : member of the same patent family, corresponding document			

2
EPO FORM 1503 03/82 (P04C01)

**ANNEX TO THE EUROPEAN SEARCH REPORT
ON EUROPEAN PATENT APPLICATION NO.**

EP 06 11 6865

This annex lists the patent family members relating to the patent documents cited in the above-mentioned European search report. The members are as contained in the European Patent Office EDP file on The European Patent Office is in no way liable for these particulars which are merely given for the purpose of information.

07-09-2006

Patent document cited in search report		Publication date	Patent family member(s)	Publication date
DE 3212527	A	13-10-1983	NONE	
DE 9419048	U	16-03-1995	IT RM940039 A1	28-07-1995
EP 1233100	A	21-08-2002	NONE	
DE 20302572	U	24-04-2003	NONE	

EPO FORM P0469

For more details about this annex : see Official Journal of the European Patent Office, No. 12/82

REFERENCES CITED IN THE DESCRIPTION

This list of references cited by the applicant is for the reader's convenience only. It does not form part of the European patent document. Even though great care has been taken in compiling the references, errors or omissions cannot be excluded and the EPO disclaims all liability in this regard.

Patent documents cited in the description

- DE 19838630 A [0003]
- EP 1205129 A [0003]
- US 2786730 A [0004]