

G. A. JOHNSON.  
 COMBINED RAIL CHAIR AND BRACE.  
 APPLICATION FILED FEB. 17, 1909.

963,294.

Patented July 5, 1910.

2 SHEETS—SHEET 1.

*Fig. 1.*

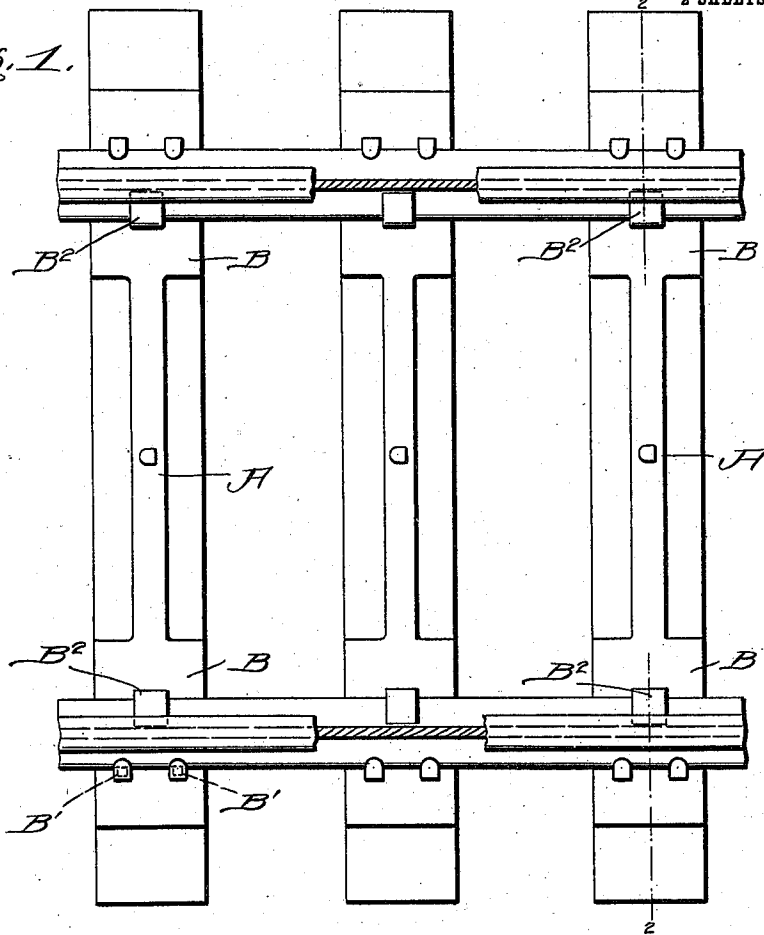

*Fig. 2.*

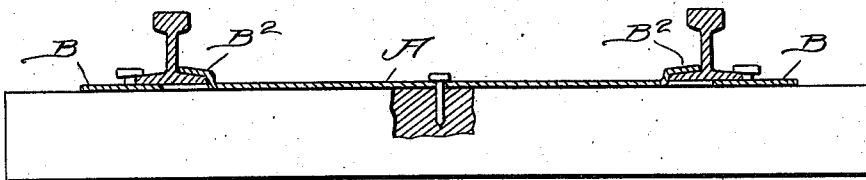

Inventor

*G. A. Johnson*

Witnesses

*Oliver H. Holmes*  
*L. M. Brooke*

*O'Meara & Brock*  
 Attorneys

G. A. JOHNSON.  
 COMBINED RAIL CHAIR AND BRACE.  
 APPLICATION FILED FEB. 17, 1909.

963,294.

Patented July 5, 1910.

2 SHEETS-SHEET 2.

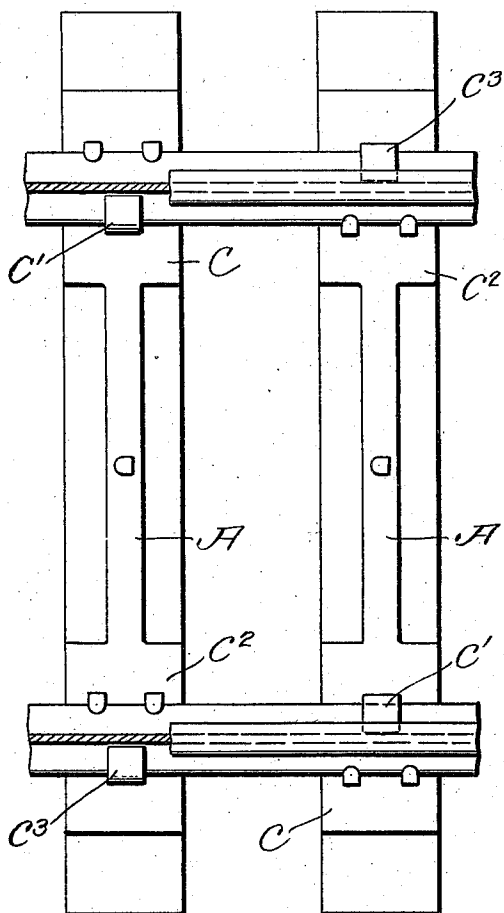

Fig. 3.

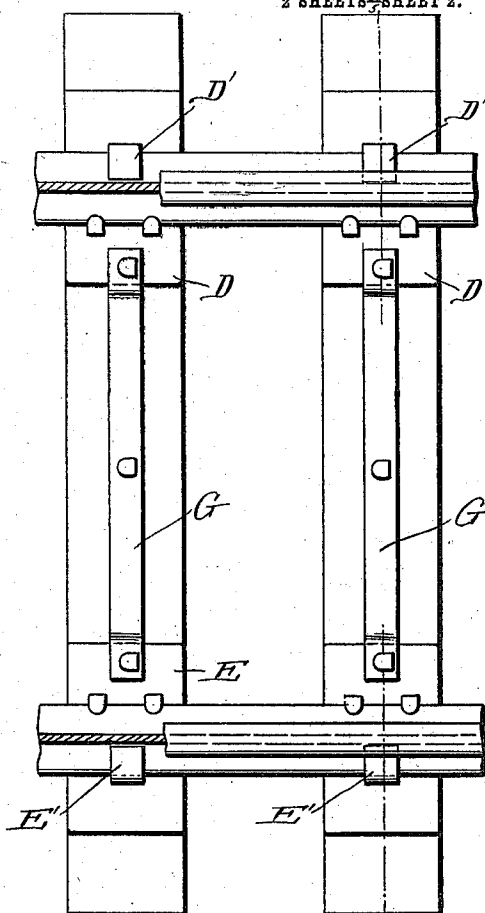

Fig. 4.

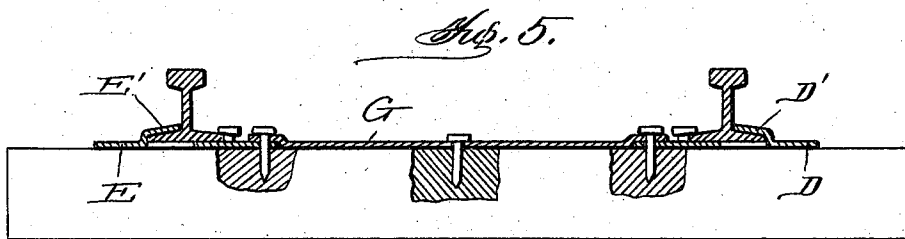

Fig. 5.

Witnesses

*Oliver M. Holmes*  
*L. M. Brooke*

Inventor

*G. A. Johnson*

*By O'Meara & Brock*  
 Attorneys

# UNITED STATES PATENT OFFICE.

GEORGE A. JOHNSON, OF SAGINAW, MICHIGAN, ASSIGNOR OF ONE-HALF TO THOMAS WHITE, OF SAGINAW, MICHIGAN.

COMBINED RAIL CHAIR AND BRACE.

963,294.

Specification of Letters Patent.

Patented July 5, 1910.

Application filed February 17, 1909. Serial No. 478,477.

*To all whom it may concern:*

Be it known that I, GEORGE A. JOHNSON, a citizen of the United States, residing at Saginaw, in the county of Saginaw and State of Michigan, have invented a new and useful Improvement in a Combined Rail Chair and Brace, of which the following is a specification.

This invention relates to a combination rail chair and brace, the object being to provide a device which is adapted to be placed on ties in such a manner that the life of the tie will be increased and at the same time the rails will be securely held.

Another object of my invention is to provide a device which will prevent the rails from spreading, said device comprising a pair of chair plates provided with means for securing the rail thereon, said plates being connected together by a bar, so that it will be impossible for the rails to spread.

A further object of the invention is to provide a chair and brace which is exceedingly simple and cheap in construction and one which is composed of a few parts which are so arranged and connected together that when in position on a tie, it is not likely to get broken.

With these objects in view, my invention consists in the novel features of construction hereinafter described, pointed out in the claim, and shown in the accompanying drawings, in which:

Figure 1 is a top plan view of my improved chair and brace showing the application of the same. Fig. 2 is a section taken on the line 2—2 of Fig. 1. Fig. 3 is a plan view of a modified form. Fig. 4 is a plan view of another modification, and Fig. 5 is a section through Fig. 4.

In carrying out my improved invention, I employ a plate which is reduced to form a bar A and a pair of chair plates B which are provided with spaced spike receiving openings B' adjacent their outer ends and with tongues B<sup>2</sup> adjacent their inner ends which are formed by slitting the plates and bending the same upwardly, said tongues being adapted to be bent over the base of the rail when placed thereon. These tongues are of such a length that they will fit over the base of the rail against the web and securely hold the rail, and after the rails

have been placed in this position, spikes are forced through the spike receiving openings into the ties which will hold the rails and the chair plates in position on the ties so that all danger of the chair moving in any manner is prevented. The central bar A is provided with an opening through which is adapted to pass a spike for securing the same to the tie, but it is of course understood that this is not necessary as after the plates have been secured in position on the ties by the spikes, the bar will be held by the same which prevents the chairs from moving with respect to each other whereby it will be impossible for the rails to spread without something giving away. This connecting bar forms a brace which not only prevents the chair plates from spreading, but serves the purpose of protecting the ties and it will be seen that when a device of this character has been placed on a tie and the rails are placed in position thereon the ties are protected to such an extent that the life of the same will be greatly increased.

Openings may be formed in the chair plates to each side of the tongues if desired through which spikes can be driven for securing the rails in addition to the tongues, but I have found by experimenting that the tongues will hold the same without any danger of the rails moving in any manner.

In Fig. 3, I show a combination chair and rail brace which is constructed in a similar manner to that of Figs. 1 and 2, but instead of having the tongues formed on the chair plates so as to be bent over the base of the rail from the inside only, I form one of the chair plates C with a tongue C' adapted to be bent over the base of the rail from the inside, and the other chair plate C<sup>2</sup> with a tongue C<sup>2</sup> adapted to be bent over the base of the rail from the outside.

In the modification shown in Figs. 4 and 5, D and E indicate a pair of chair plates adapted to be arranged on the tie in the ordinary manner, said plates being provided with tongues D', E' which are bent over the bases of the rails from the outside so as to securely fasten the same and the plates are provided with spike receiving openings through which spikes are adapted to pass which extend over the bases of the

rails from the inside and securely fasten the chair plates, rails and ties together whereby all danger of the chairs and rails moving is prevented. These plates are provided with openings adjacent their inner ends over which are arranged the apertured ends of a connecting bar G through which spikes are adapted to be driven for securing the bar to the plates and for holding the plates on the ties and this bar G is preferably formed with a central opening so that a spike can be driven through the same whereby it will be secured to the tie. While I have shown and described this particular manner of fastening the connecting bar to the chair plates, it is of course understood that other means can be employed such as a bolt and nut without departing from the spirit of my invention.

From the foregoing description, it will be seen that I have provided a combined chair, and rail brace which is adapted to be placed on the ties and is of such a size that when the rails are placed thereon and secured, the proper gage will be obtained whereby all danger of the rails moving or spreading in any manner is prevented.

Having thus fully described my inven-

tion, what I claim as new and desire to secure by Letters Patent, is:

A combined rail chair and brace comprising rectangular shaped plates adapted to be arranged on the ties provided with spaced openings in transverse alinement and additional openings adjacent their inner edges, said plates being provided with tongues spaced from said openings and adapted to fit over the outer flanges of the rail, said tongues being formed by cutting U-shaped slots in said plates and bending the intermediate portions upwardly, spikes extending through said alining openings of said plates engaging the inner flanges of said rails, a bar having off-set apertured ends adapted to fit over and register with the openings formed in said plates adjacent their inner edges, spikes extending through said registering openings of the bar and plates, together with a central spike for securing said bar to the tie intermediate its ends.

GEORGE A. JOHNSON.

Witnesses:

E. A. PERKINS,  
O. L. FRASER.