



(11) **EP 2 286 010 B1**

(12) **EUROPEAN PATENT SPECIFICATION**

(45) Date of publication and mention of the grant of the patent:  
**30.01.2013 Bulletin 2013/05**

(51) Int Cl.:  
**D03C 7/00** <sup>(2006.01)</sup> **D03C 7/02** <sup>(2006.01)</sup>  
**B65H 51/20** <sup>(2006.01)</sup> **B65H 59/12** <sup>(2006.01)</sup>

(21) Application number: **09733942.8**

(86) International application number:  
**PCT/EP2009/002722**

(22) Date of filing: **14.04.2009**

(87) International publication number:  
**WO 2009/129950 (29.10.2009 Gazette 2009/44)**

(54) **DEVICE FOR THE TENSIONING OF A LENO THREAD FOR A DOUP HEDDLE DEVICE FOR A WEAVING MACHINE**

VORRICHTUNG ZUM ANSPANNEN EINES DREHERFADENS EINER DREHERVORRICHTUNG FÜR EINE WEBMASCHINE

DISPOSITIF POUR LA TENSION D'UN FIL DE GAZE POUR UN DISPOSITIF DE DEMI-LISSE POUR UN MÉTIER À TISSER

(84) Designated Contracting States:  
**AT BE BG CH CY CZ DE DK EE ES FI FR GB GR HR HU IE IS IT LI LT LU LV MC MK MT NL NO PL PT RO SE SI SK TR**

(30) Priority: **21.04.2008 BE 200800237**

(43) Date of publication of application:  
**23.02.2011 Bulletin 2011/08**

(73) Proprietor: **Picanol**  
**8900 Ieper (BE)**

(72) Inventor: **MEYNS, Ignace**  
**B-8647 Reninge (BE)**

(74) Representative: **Patentanwälte**  
**Ruff, Wilhelm, Beier, Dauster & Partner**  
**Kronenstrasse 30**  
**70174 Stuttgart (DE)**

(56) References cited:  
**DE-A1- 2 420 390 US-A- 2 647 541**  
**US-A- 3 493 013**

**EP 2 286 010 B1**

Note: Within nine months of the publication of the mention of the grant of the European patent in the European Patent Bulletin, any person may give notice to the European Patent Office of opposition to that patent, in accordance with the Implementing Regulations. Notice of opposition shall not be deemed to have been filed until the opposition fee has been paid. (Art. 99(1) European Patent Convention).

## Description

**[0001]** The invention relates to a device for the tensioning of a leno thread for a doup heddle device for a weaving machine according to the preamble of claim 1 and to a weaving machine with a device according to the preamble of claim 7.

**[0002]** In weaving machines, it is known to apply a doup heddle device, also known as a leno heddle device, in order to form a leno weave structure using what are known as fixed and alternating leno threads together with weft threads. In this case, two leno threads are brought each from a thread supply, via a thread compensator, a fixedly positioned thread guide, a thread stop motion and a thread holding-down member to a doup heddle device consisting of two lifting heddles which interact with a doup heddle. Despite the presence of a thread compensator positioned in proximity to the thread supply, a doup heddle device of this type is unable to accommodate the difference in length in the leno threads resulting from the upward and downward movement. This is also accompanied by undesirably high variations in the tension in the leno threads. This also has the consequence that no good weaving shed can be formed with the leno threads and that this can result in weaving faults. This occurs particularly at high weaving speeds.

**[0003]** It is known from "Watson's Advanced Textile Design, Compound Woven Structures; Z.J. Grosicki (1913); ISBN 0 408 00250 6; page 231", as represented in figure 1, to position a thread holding-down member in proximity to the doup heddle device with a bending point which is resiliently mounted.

**[0004]** Doup heddle devices of this type are furthermore also known from US 2647541, which is considered to be the closest prior art, US 2389258, EP 1036228A1 and BE 1012453. This allows to compensate for tension variations in the leno threads. However, a problem arises when a compensation of this type is provided for the alternating leno thread which forms the bottom shed. The bottom shed is then no longer absolutely defined; that is to say, the alternating leno thread has no fixed vertical position, as a result of which there is the risk that the alternating leno thread which forms the bottom shed will come into contact with the weft thread or with an insertion element such as a gripper, a gripper band or the like during insertion. As a result, the weft thread or the alternating leno thread can become disturbed or damaged, and this can cause a fault in the woven material or the interrupting of the weaving process. In order to avoid the foregoing, the bending point for the alternating leno thread can be chosen to be sufficiently low in order not to disrupt the weft thread or an insertion element. However, this increases the requirements for the compensation, since greater length has to be compensated for, leading to greater movements of the compensation element and greater tension variations. A too low bottom shed in the lowest position can then again cause less efficient binding of the weft thread in proximity to the edge

of the woven material. It is furthermore also known for the alternating leno thread which forms the bottom shed to attach a lifting heddle instead of compensation by means of a resiliently mounted bending point. However, this leads to a complex construction and the high tension variations in this alternating leno thread are again insufficiently compensated for, as a result of which weaving faults can also occur.

**[0005]** An object of the invention is a device of the aforementioned type which is intended to be applied together with a doup heddle device for a weaving machine which allows a well-defined bottom shed to be set and which continues to sufficiently compensate for differences in tension in the leno threads.

**[0006]** In the case of an aforementioned device for the tensioning of a leno thread, which device can be positioned in proximity to a doup heddle device and comprises for at least one leno thread a resiliently mounted thread guide which forms a bending point for the leno thread, this object is achieved in that the device also comprises a fixedly mountable thread guide as defined in claim 1.

**[0007]** In this way, with a simple construction, a desired weaving shed is ensured at all times and the difference in length occurring in the leno threads is sufficiently compensated for. This prevents the leno threads from being subjected to a too high tension and a leno thread from becoming damaged, during the insertion of a weft thread, by for example a weft thread or an insertion element such as a gripper and the like. In this way the risk of a fault in the woven material as a consequence thereof is greatly reduced.

**[0008]** According to the invention, the bending point of the fixedly mountable thread guide forms in use the last bending point of the leno thread before the doup heddle device. As a result of the fact that in this case the leno threads are no longer bent from the fixedly mounted thread guide up to the doup heddle device, a positioning in the direction of movement of the leno threads just before the doup heddle device allows an optimal compensation for the differences in tension in the leno threads.

**[0009]** The device according to the invention comprises a resiliently mounted thread guide which is supported by a resilient element. According to one embodiment, the resilient element consists of a resilient material, such as spring steel or synthetic material. Also, the resilient element can be embodied as a leaf spring, a spring wire, a spiral spring or the like. This allows a simple construction of the device according to the invention.

**[0010]** According to a further embodiment, the holder for the fixedly mountable thread guide and the resiliently mounted thread guide can be fastened for example to a warp stop motion. This allows the device according to the invention to be fastened in a simple manner to an existing weaving machine.

**[0011]** The invention further includes a weaving machine with a device for the tensioning of a leno thread according to the invention which can be positioned in proximity to a doup heddle device. The thread guide,

which is fixedly positioned in proximity to the doup heddle device, of the aforementioned device allows a desired weaving shed to be formed, while the resiliently mounted thread guide allows compensation to be provided for the difference in length or for the tension in the leno threads.

**[0012]** Further features and advantages of the invention will emerge from the sub-claims and the embodiment represented hereinafter in the description.

**[0013]** In the drawings:

figure 1 shows a known device with a doup heddle device;

figure 2 shows a weaving machine with a device according to the invention;

figure 3 shows a side view of a device according to the invention;

figure 4 shows a top view of the device according to figure 3 which is suited for four leno threads;

figure 5 shows a perspective view of a device according to the invention;

figure 6 shows a side view of a variant embodiment of a device which is not according to the invention; and

figure 7 shows a top view of the device according to figure 6.

**[0014]** In the weaving machine represented in figure 2, two leno threads 2 and 3 are each brought from a thread supply, such as a bobbin 4 or 5, via a thread compensator 6 or 7, a fixedly positioned thread guide 8, a warp stop motion 9, and a device 10 according to the invention, to a doup heddle device 11. The doup heddle device 11 can consist, as is known from DE 3818680 C1, of two lifting heddles 12 and 13 which can interact with a doup heddle 14, whereby each lifting heddle 12, 13 can lift the doup heddle 14. Also represented schematically are a warp beam 15 with warp threads 16, shed formation devices 17, a reed 18, and a cloth beam 19. The leno thread 2, which is guided through the doup heddle 14, is also referred to as the fixed leno thread, while the leno thread 3, which is guided around the doup heddle 14 and between an associated lifting heddle 12, 13, is also referred to as the alternating leno thread or alternating thread.

**[0015]** The weaving machine as represented in figure 2 shows a doup heddle device 11 and a device 10 according to the invention which is positioned in proximity to the doup heddle device 11. The device 10 comprises, as represented in greater detail in figures 2 to 4, for each leno thread 2, 3 a resiliently mounted thread guide 20 which forms a bending point 21 for a leno thread 2, 3. The thread guide 20 comprises a thread guide element which forms a bending point 21 for a leno thread 2, 3 and is resiliently mounted by means of a resilient element 22 to which the bending point 21 is attached. The resiliently mounted thread guide 20 is supported by the resilient element 22. The represented resilient element 22 is embodied as a leaf spring. The resilient element 22 can be

made of spring steel, a synthetic material or another elastic material. The synthetic material used can be a polymer, a fiber-reinforced polymer, a glass fiber composite or any other known synthetic material having resilient properties. The use of synthetic material can be advantageous, as synthetic material usually also displays damping properties. According to a variant (not shown), the resilient element 22 can also be embodied as a spring wire made of elastic material.

**[0016]** The resilient element 22 is attached to a holder 23 using fastening elements 24, for example a screw connection. According to a variant (not shown), the resilient element 22 can be attached to a holder by means of a glue connection or snap connection, or be made in one piece with a holder. Furthermore, a thread eye 25 is also arranged to guide a leno thread 2, 3 in proximity to the warp stop motion. This thread guide 25 can for example be embodied in a similar manner to the first bending point 21.

**[0017]** As represented in figure 2, the holder 23 is arranged in proximity to the warp stop motion 9. The holder 23 can for example be fastened to a transverse support 35 of the warp stop motion 9, while the warp stop motion 9 can be fastened to the frame of the weaving machine. It is clear that the holder 23 can also be fastened to the frame of the weaving machine directly or in a different manner. The device 10 according to the invention is located in this case in the warp direction between the warp stop motion 9 and the doup heddle device 11.

**[0018]** According to a variant (not shown), the thread eyes 25 can be omitted and the leno threads 2, 3 can be guided for example on a transverse support 35 of the warp stop motion 9 to which the holder 23 is for example attached.

**[0019]** The embodiment of the device 10 according to the invention as represented in figures 2 to 4 comprises a fixedly mountable thread guide 30 which forms a bending point 31 for a leno thread 2, 3. The bending point 31 is fixedly mounted. As represented in figures 3 and 4, the thread guide 30 is attached to an arm 32 which is fastened to a holder 23 by means of fastening elements 33, such as a screw connection or a glue connection. The bending point 31 is in the represented embodiment embodied as a thread separator which was fastened to the arm 32 by means of fastening elements 34. The thread separator as represented in figures 3 and 4 can for example be made of ceramic, or be provided with a wear-resistant layer and consist of four thread guides positioned next to one another.

**[0020]** In the embodiment of figures 3 and 4, the device 10 comprises four separately, resiliently mounted thread guides 20 and four fixedly mounted thread guides 30 for associated leno threads. Figure 4 shows that a leno thread 2 is guided through a set of thread guides 20, 30 and a leno thread 3 through another set of thread guides 20, 30. In a similar manner two other leno threads can also be guided in order to keep them tensioned. If weaving is carried out using two doup heddle devices 11, a

device 10 can, as represented in figure 4, guide four leno threads and keep them tensioned. It is clear that the represented device 10 can interact with one, two, three or four leno threads.

**[0021]** According to a variant (not shown), the bending point 31 can also be embodied as a simple shaft or with the aid of single thread eyes which, if appropriate on a fastening plate, are fastened to an arm. According to still another variant embodiment, the holder and/or the arm and/or the bending point 31 can be made in one piece.

**[0022]** The thread guide 30, which forms a bending point 31 which is mounted fixedly and which in use is positioned in proximity to the doup heddle device 11, allows a clearly defined weaving shed 36 to be formed with the leno threads 2, 3, irrespective of the compensating action of the resiliently mounted bending point 21. The weaving shed 36 formed is defined by the position of the lowest leno threads 3 which define what is known as a bottom shed 37 and by the position of the uppermost leno threads 2 which define what is known as a top shed 38. The position of the bending point 31 defines in this case the position of the bottom shed, while the position of the thread eye of the doup heddle 14 defines the position of the top shed.

**[0023]** Since in this embodiment the bending point 31 of the thread guide 30 forms in use the last bending point of the leno threads 2, 3 before the doup heddle device 11, the position of this bending point 31 defines in most doup heddle devices 11 the location of the bottom shed of the leno threads 2 and 3. In this case, the term "before" refers to a place in the direction of movement of the leno threads just before the doup heddle device 11. This means that no bending point remains present for a leno thread 2 or 3 between the bending point 31 of the thread guide 30 and the doup heddle device 11. Since the bending point 21, which is mounted resiliently, is positioned in proximity to the fixedly mounted bending point 31, the differences in tension in the leno threads 2, 3 are sufficiently compensated for. The positioning of the bending points 31 allows slight bending around each bending point 31, as a result of which the friction between a bending point 31 and a leno thread 2, 3 is low.

**[0024]** A leno thread 2, 3, which is guided from a thread supply to a bending point 21 and subsequently via the bending point 31 to a doup heddle device 11, can be kept tensioned by the resiliently mounted bending point 21, as the resiliently mounted bending point 21 can cause a length compensation of the leno thread 2, 3 between the thread supply and the doup heddle device 11. This length compensation at the level of the device 10 according to the invention is advantageous, as the device 10 according to the invention is positioned in proximity to the doup heddle device 11.

**[0025]** The bending point 21 represented in figure 5 for a leno thread is formed by a thread guide element in the form of a thread eye which is attached to a resilient element 22. This attaching can for example be carried out by folding back the resilient element 22, which is embod-

ied as a leaf spring, and providing therein an opening wherein, if appropriate, it is possible to attach an insert 39 which is made of ceramic material and forms the thread guide element. According to an alternative embodiment, a thread eye is for example made of ceramic material and is attached to the resilient element 22, for example by means of a screw or glue connection.

**[0026]** Figures 6 and 7 represent a variant embodiment of the device 10 which is not according to the invention. Similar components to those in the embodiment represented in figures 2 to 5 are denoted by the same reference numerals. In this embodiment, the device 10 also comprises a bending point 21 which is resiliently mounted and a bending point 31 which is fixedly mounted. The bending point 31 is represented likewise as in the embodiment of figures 2 to 5 and is formed by a thread separator which is fastened to an arm 32 by means of fastening elements 34. This arm 32 is in turn fastened to the holder 23 by means of fastening elements 33. The bending point 21, which is resiliently mounted, is embodied as a thread eye which is attached, for example by means of a glue connection, to a resilient element 22 which in this embodiment is embodied as a spiral spring. This resilient element is in turn fastened to an L-shaped holder 26, on which an arm 27 is fastened to a slot 29 of the arm 32 for the fixedly mounted thread guide 30 by means of fastening elements 28, for example a screwed connection. This allows the relative distance between the resiliently mounted bending point 21 and the fixedly mounted bending point 31, and thus the bending of the leno threads 2, 3 at the level of these bending points 21, 31, to be set in a simple manner.

**[0027]** Obviously, the bending points 21, 31 do not necessarily have to consist of a thread eye or thread separator, but can take any shape allowing the bending of a leno thread 2, 3. Obviously, the resilient element 22 does not necessarily have to have in the tensionless state a substantially straight shape as represented in figure 3, but can for example have a somewhat curved shape or if appropriate be embodied in a substantially L-shaped manner.

**[0028]** In the embodiment as represented in figure 2, the device 10 is applied as a thread holding-down member; this means that the leno threads 2 and 3 are held down around the bending points 31. According to another possibility, the device according to the invention can also be positioned mirror-symmetrically with respect to the warp thread plane 16 in order to hold up in this way the leno threads and to act as a thread holding-up member. In this last case, the doup heddle device should also be positioned mirror-symmetrically with respect to the warp thread plane 16. However, the operation of a device 10 according to the invention remains the same, irrespective of whether the device is applied as a thread holding-down member or as a thread holding-up member. Obviously, as far as the aforementioned description is concerned, the bottom shed and top shed should then be applied in an appropriate manner.

**[0029]** It is clear that variant embodiments of the device 10 according to the invention are possible for at least one leno thread. It is however preferable to keep under tension or to tension both leno threads using a device 10 according to the invention. Depending on the number of doup heddle devices 11, a device 10 according to the invention can then interact with respectively two, four, six, eight or more leno threads. In this case, for example two, four, six, eight or more thread guides 20, 30 can be attached to the same or to separate holders. For example, at least two devices 10 according to the invention, which are for example each attached to a side of the weaving shed formed by the warp threads, are attached to a weaving machine according to the invention.

**[0030]** Obviously, a device and a weaving machine according to the invention represented in the claims are not limited to the illustrated and described exemplary embodiments, but rather can also comprise variants and combinations of these exemplary embodiments which fall under the claims.

### Claims

1. A device for the tensioning of a leno thread (2, 3) for a doup heddle device (11) for a weaving machine which can be positioned in proximity to the doup heddle device (11), wherein the device (10) comprises a thread guide (20) for at least one leno thread (2, 3) which forms a bending point (21) for the leno thread (2, 3), wherein the thread guide (20) is resiliently mounted by means of a resilient element (22), the resilient element (22) being attached to a holder (23), and wherein the device (10) also comprises a fixedly mountable thread guide (30) which forms a bending point (31) for the leno thread (2, 3), **characterized in that** the fixedly mountable thread guide (30) is attached to an arm (32) which is fastened on the holder for positioning the fixedly mountable thread guide (30) in use in proximity to the doup heddle device (11), so that the thread guide (30) forms in use the last bending point for the leno threads (2, 3) before the doup heddle device (11).
2. The device according to claim 1, **characterized in that** the resilient element (22) consists of a resilient material, such as spring steel or synthetic material.
3. The device according to claim 2, **characterized in that** the resilient element (22) is embodied as a leaf spring.
4. The device according to claim 2, **characterized in that** the resilient element (22) is embodied as a wire spring.
5. The device according to claim 2, **characterized in that** the resilient element (22) is embodied as a spiral

spring.

6. The device according to claim 1, **characterized in that** the holder (23) can be fastened to a warp stop motion (9).
7. A weaving machine with a device for the tensioning of a leno thread (2, 3) for a doup heddle device (11), **characterized in that** the weaving machine comprises a device (10) according to any one of claims 1 to 6, which is positioned in proximity to a doup heddle device (11).

### 15 Patentansprüche

1. Vorrichtung zum Spannen eines Dreherfadens (2, 3) für eine Drehevorrichtung (11) für eine Webmaschine, die in der Nähe der Drehevorrichtung (11) positioniert werden kann, wobei die Vorrichtung (10) einen Fadenführer (20) für mindestens einen Dreherfaden (2, 3) umfasst, der eine Biegestelle (21) für den Dreherfaden (2, 3) bildet, wobei der Fadenführer (20) mittels eines elastischen Elements (22) elastisch montiert ist, das elastische Element (22) auf einer Halterung (23) angebracht ist, und wobei die Vorrichtung (10) auch eine fest montierte Fadenführung (30) umfasst, die eine Biegestelle (31) für den Dreherfaden (2, 3) bildet, **dadurch gekennzeichnet dass** die fest montierte Fadenführung (30) auf einem Arm (32) angebracht ist, der auf der Halterung befestigt ist zum Positionieren der fest montierten Fadenführung (30) im Gebrauch in der Nähe der Drehevorrichtung (11), so dass der Fadenführer (30) im Gebrauch die letzte Biegestelle für die Dreherfäden (2, 3) vor der Drehevorrichtung (11) bildet.
2. Vorrichtung nach Anspruch 1, **dadurch gekennzeichnet, dass** das elastische Element (22) aus einem elastischen Material, wie Federstahl oder aus einem synthetischen Material besteht.
3. Vorrichtung nach Anspruch 2, **dadurch gekennzeichnet, dass** das elastische Element (22) als Blattfeder ausgebildet ist.
4. Vorrichtung nach Anspruch 2, **dadurch gekennzeichnet, dass** das elastische Element (22) als Drahtfeder ausgebildet ist.
5. Vorrichtung nach Anspruch 2, **dadurch gekennzeichnet, dass** das elastische Element (22) als Spiralfeder ausgebildet ist.
6. Vorrichtung nach Anspruch 1, **dadurch gekennzeichnet, dass** die Halterung (23) auf einem Kettfadenwächter (9) befestigt werden kann.

7. Webmaschine mit einer Vorrichtung zum Spannen eines Dreherfadens (2, 3) für eine Drehvorrichtung (11), **dadurch gekennzeichnet, dass** die Webmaschine eine Vorrichtung (10) nach einem der Ansprüche 1 bis 6 enthält, die in der Nähe eines Drehvorrichtung (11) positioniert ist. 5

## Revendications

- 10
1. Dispositif pour la tension d'un fil de gaze (2, 3) pour un dispositif de lisse de gaze (11) pour une machine à tisser, qui peut être positionné à proximité du dispositif de lisse de gaze (11), dans lequel le dispositif (10) comprend un guide-fil (20) pour au moins un fil de gaze (2, 3), qui forme un point de flexion (21) pour le fil de gaze (2, 3), dans lequel le guide-fil (20) est monté de manière résilient au moyen d'un élément résilient (22), l'élément résilient (22) étant attaché à un support (23), et dans lequel le dispositif (10) comprend également un guide-fil (30) monté fixement qui forme un point de flexion (31) pour le fil de gaze (2, 3), **caractérisé en ce que** le guide-fil (30) monté fixement est attaché à un bras (32) qui est fixé au support pour positionner le guide-fil (30) monté fixement en cours d'utilisation à proximité du dispositif de lisse de gaze (11) de telle sorte que le guide-fil (30) forme en cours d'utilisation le dernier point de flexion pour les fils de gaze (2, 3) devant le dispositif de lisse de gaze (11). 15 20 25 30
2. Dispositif selon la revendication 1, **caractérisé en ce que** l'élément résilient (22) consiste en une matière résiliente, comme ressort en acier ou en une matière synthétique. 35
3. Dispositif selon la revendication 2, **caractérisé en ce que** l'élément résilient (22) est conçu comme un ressort à lames. 40
4. Dispositif selon la revendication 2, **caractérisé en ce que** l'élément résilient (22) est conçu comme un ressort métallique. 45
5. Dispositif selon la revendication 2, **caractérisé en ce que** l'élément résilient (22) est conçu comme un ressort spiral. 50
6. Dispositif selon la revendication 1, **caractérisé en ce que** le support (23) peut être fixé sur un casse-chaîne (9). 55
7. Machine à tisser avec un dispositif pour la tension d'un fil de gaze (2, 3) pour un dispositif de lisse de gaze (11), **caractérisée en ce que** la machine à tisser comprend un dispositif (10) selon l'une quelconque des revendications 1 à 6, qui est positionnée à proximité d'un dispositif de lisse de gaze (11).

Fig. 1

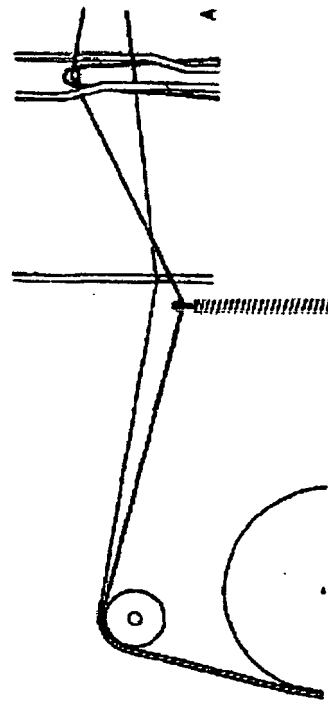
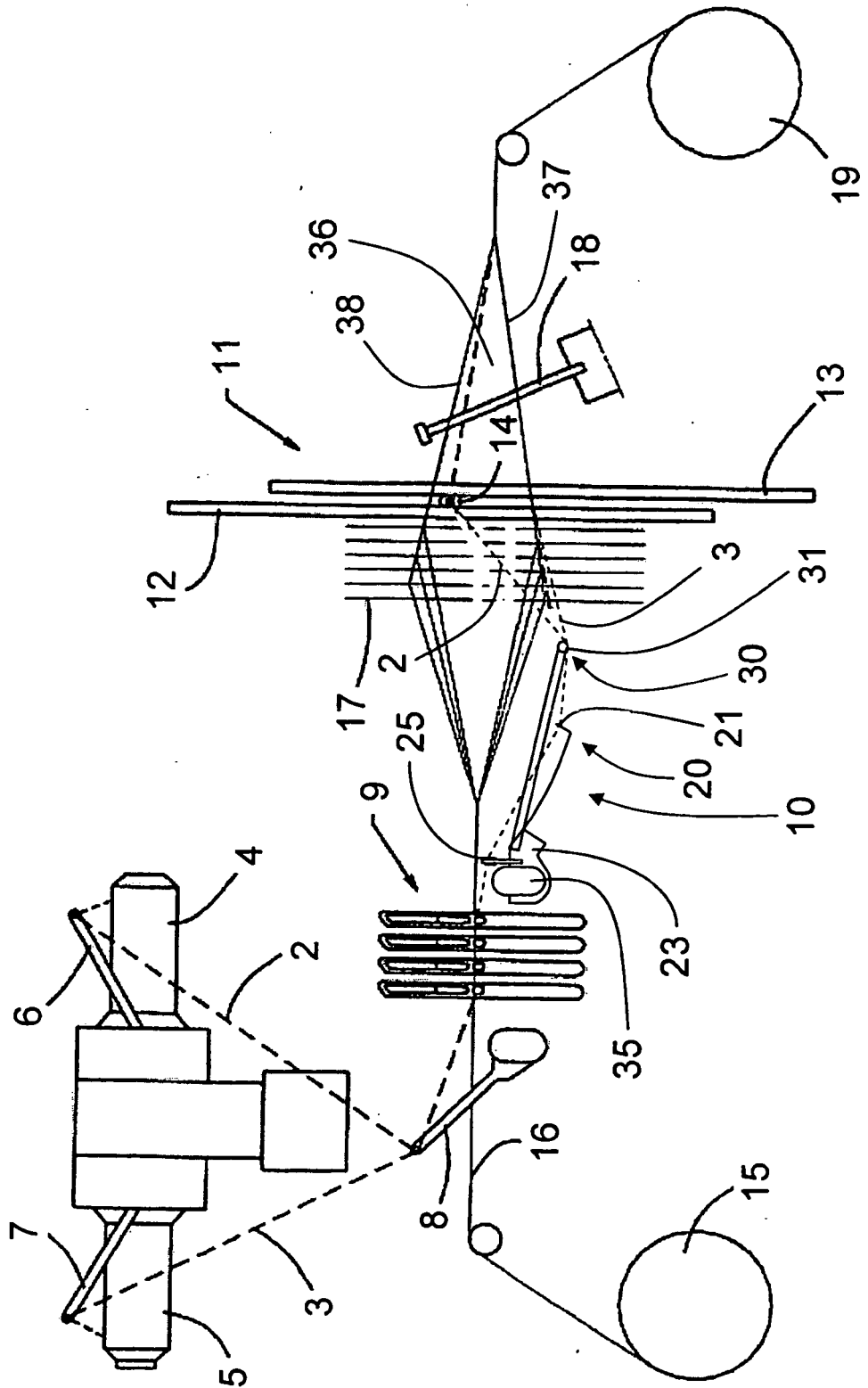

Fig. 2



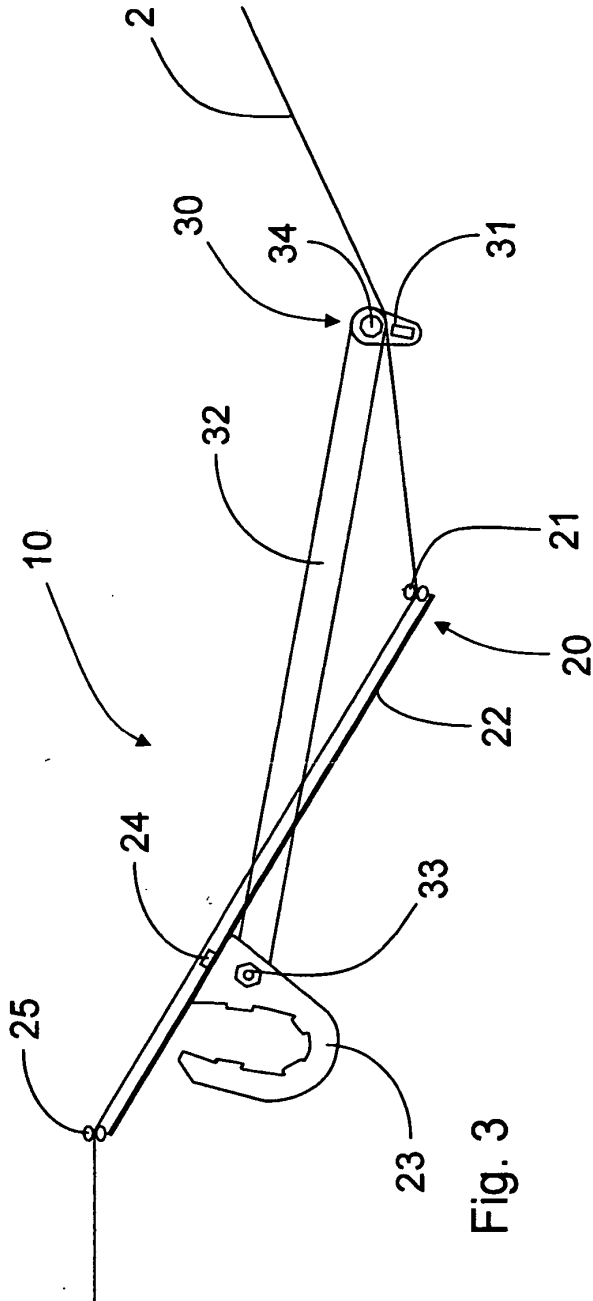

Fig. 3

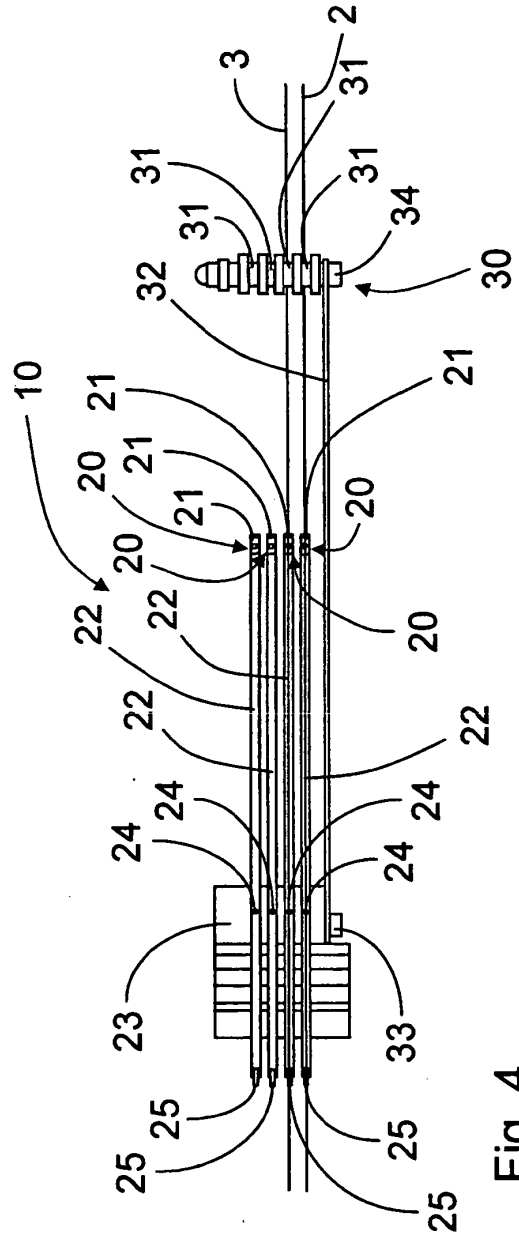
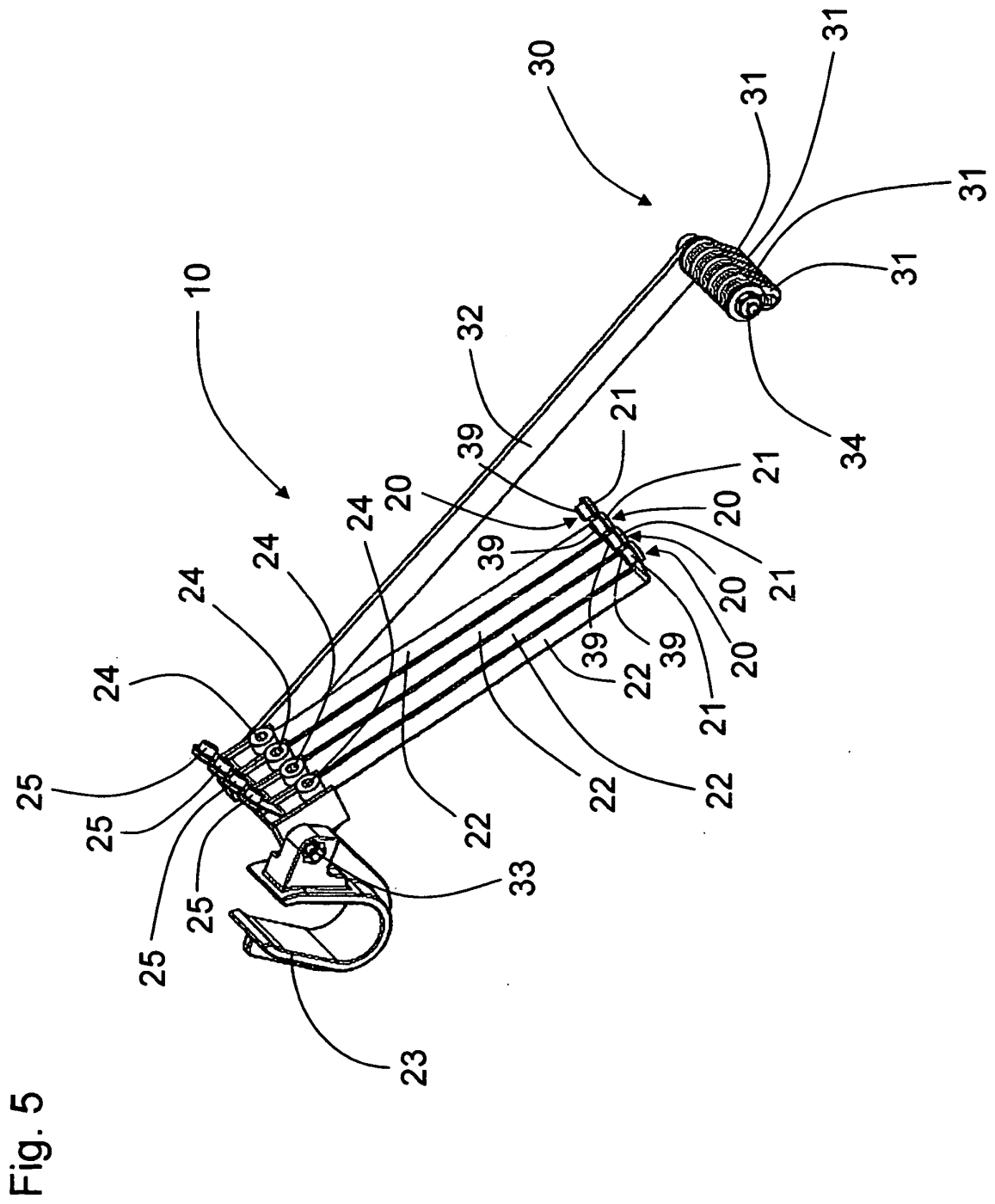

Fig. 4



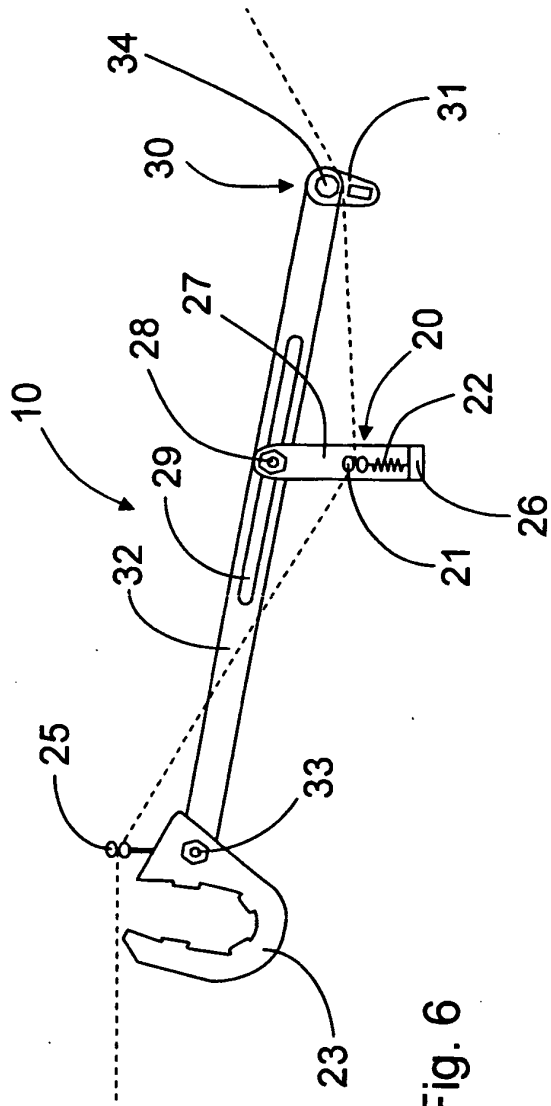

Fig. 6

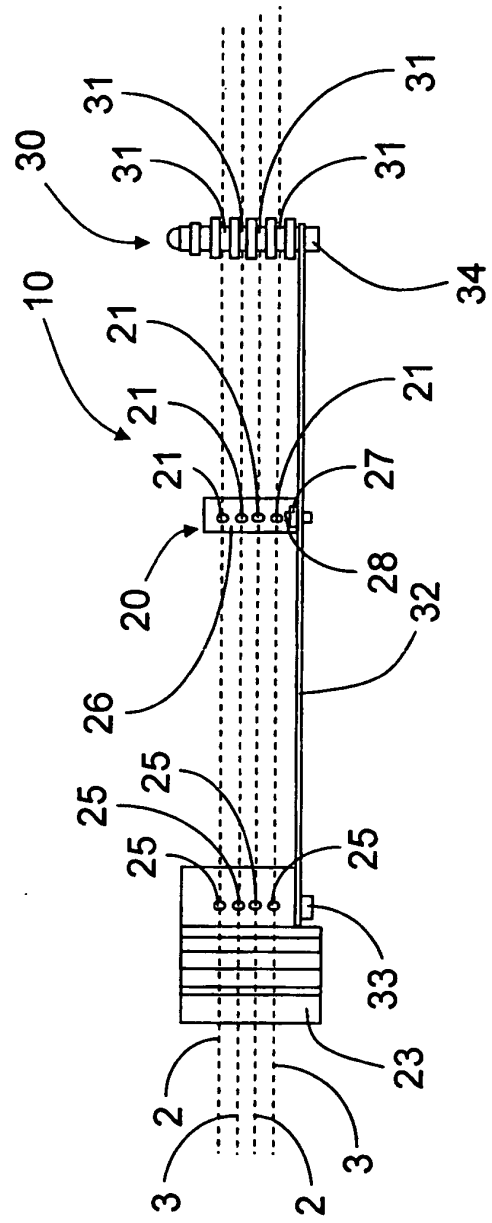

Fig. 7

**REFERENCES CITED IN THE DESCRIPTION**

*This list of references cited by the applicant is for the reader's convenience only. It does not form part of the European patent document. Even though great care has been taken in compiling the references, errors or omissions cannot be excluded and the EPO disclaims all liability in this regard.*

**Patent documents cited in the description**

- US 2647541 A [0004]
- US 2389258 A [0004]
- EP 1036228 A1 [0004]
- BE 1012453 [0004]
- DE 3818680 C1 [0014]

**Non-patent literature cited in the description**

- **Z.J. GROSICKI.** Watson's Advanced Textile Design. *Compound Woven Structures*, 1913, ISBN 0 408 00250 6, 231 [0003]