

(19) World Intellectual Property
Organization
International Bureau



(43) International Publication Date
5 August 2004 (05.08.2004)

PCT

(10) International Publication Number
WO 2004/064698 A2

- (51) International Patent Classification⁷: **A61G**
- (21) International Application Number:
PCT/US2004/001070
- (22) International Filing Date: 14 January 2004 (14.01.2004)
- (25) Filing Language: English
- (26) Publication Language: English
- (30) Priority Data:
60/440,209 15 January 2003 (15.01.2003) US
- (71) Applicant (for all designated States except US):
STRYKER CORPORATION A CORPORATION OF THE STATE OF MICHIGAN [US/US]; 2725 Fairfield Road, P.o. Box 4085, Kalamazoo, Michigan 49003-4085 (US).
- (72) Inventors; and
- (75) Inventors/Applicants (for US only): **LAMBARTH, Clifford, E.** [US/US]; 6933 Oakland Drive, Portage, Michigan 49024 (US). **WAY, Christopher, B.** [US/US]; 10770 East Cd Avenue, Richland, Michigan 49083 (US).
- (74) Agents: **BOUTELL, David, G.** et al.; 2026 Rambling Road, Kalamazoo, MI 49008-1631 (US).
- (81) Designated States (unless otherwise indicated, for every kind of national protection available): AE, AG, AL, AM, AT, AU, AZ, BA, BB, BG, BR, BW, BY, BZ, CA, CH, CN, CO, CR, CU, CZ, DE, DK, DM, DZ, EC, EE, EG, ES, FI, GB, GD, GE, GH, GM, HR, HU, ID, IL, IN, IS, JP, KE, KG, KP, KR, KZ, LC, LK, LR, LS, LT, LU, LV, MA, MD, MG, MK, MN, MW, MX, MZ, NA, NI, NO, NZ, OM, PG, PH, PL, PT, RO, RU, SC, SD, SE, SG, SK, SL, SY, TJ, TM, TN, TR, TT, TZ, UA, UG, US, UZ, VC, VN, YU, ZA, ZM, ZW.
- (84) Designated States (unless otherwise indicated, for every kind of regional protection available): ARIPO (BW, GH, GM, KE, LS, MW, MZ, SD, SL, SZ, TZ, UG, ZM, ZW), Eurasian (AM, AZ, BY, KG, KZ, MD, RU, TJ, TM), European (AT, BE, BG, CH, CY, CZ, DE, DK, EE, ES, FI, FR, GB, GR, HU, IE, IT, LU, MC, NL, PT, RO, SE, SI, SK, TR), OAPI (BF, BJ, CF, CG, CI, CM, GA, GN, GQ, GW, ML, MR, NE, SN, TD, TG).
- Published:**
— without international search report and to be republished upon receipt of that report
- For two-letter codes and other abbreviations, refer to the "Guidance Notes on Codes and Abbreviations" appearing at the beginning of each regular issue of the PCT Gazette.

(54) Title: AMBULANCE COT LOADING AND UNLOADING DEVICE

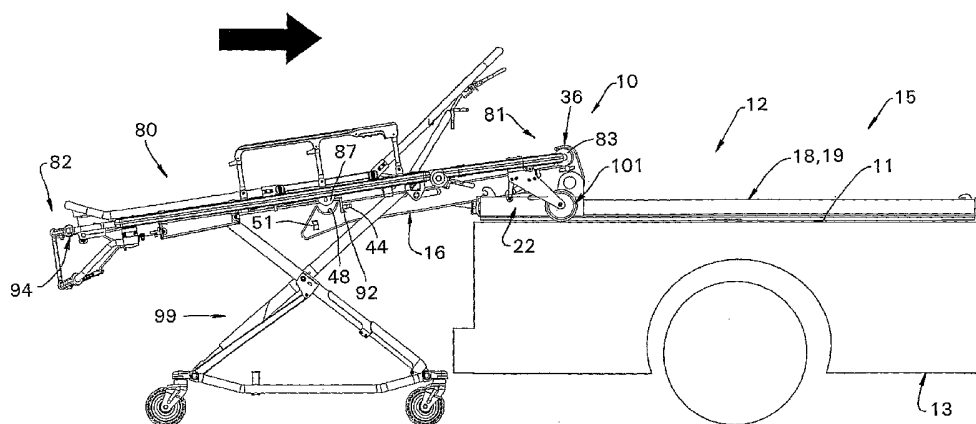

(57) Abstract: An ambulance cot loading and unloading device which utilizes an elongate guide track configured for mounting to a floor surface of a cargo area on the ambulance. A trolley is supported for movement relative to the guide track and has an elongate boom. The ambulance cot has a powered collapsible and extendable base and a patient support deck mounted on the base. A connection mechanism is provided on the trolley and the ambulance cot which is configured to interconnect and securely hold the ambulance cot on the trolley.

WO 2004/064698 A2

AMBULANCE COT LOADING AND UNLOADING DEVICE

FIELD OF THE INVENTION

[0001] This invention relates to an ambulance cot loading and unloading device and methodology, as well as an ambulance cot support arrangement, especially suitable for ambulances.

BACKGROUND OF THE INVENTION

[0002] Emergency medical service (EMS) personnel are required to handle the combined weight of a patient and the ambulance cot during various stages of insertion of the ambulance cot into the cargo area of an ambulance. In some instances, the head end of the ambulance cot needs to be lifted by a first EMS attendant for insertion into the cargo area so that the head end wheels become supported on the floor surface of the cargo area as the base construction for the ambulance cot is collapsed thereby necessitating a second EMS attendant to lift the combined weight of the ambulance cot and patient at the foot end of the ambulance cot during the completion of an insertion of the ambulance cot into the cargo area. The same requirement exists when the ambulance cot with a patient thereon is removed from the cargo area. In some instances, there exists a risk of back injury to the EMS personnel as a result of this lifting and insertion as well as removal methodology. In addition, there is a risk of injury to the patient on the ambulance cot when an EMS attendant is injured and is no longer able to support the ambulance cot and the patient thereon when the ambulance cot is spaced above the ground during insertion or removal thereof from the cargo area. Accordingly, it is advantageous to provide an ambulance cot loading and unloading device as well as methodology for accomplishing same as well as providing an ambulance cot support arrangement in the ambulance which will

minimize the likelihood of injury to the patient during transport.

SUMMARY OF THE INVENTION

[0003] The objects and purposes of the invention are met by providing an ambulance cot loading and unloading device which utilizes an elongate guide track configured for mounting to a floor surface of a cargo area on the ambulance. A trolley is supported on the elongate guide track for movement relative to the guide track. The trolley is configured to extend to a location outside of the cargo area when the trolley is in a first position and additionally configured to be housed entirely inside the cargo area when the trolley is not in the first position. The ambulance cot has a collapsible and extendable base and a patient support deck mounted on the base. A connection mechanism is provided on the trolley and the ambulance cot which is configured to interconnect and securely hold the ambulance cot on the trolley.

BRIEF DESCRIPTION OF THE DRAWINGS

[0004] Other objects and purposes of this invention will be apparent to persons acquainted with apparatus of this general type upon reading the following specification and inspecting the accompanying drawings in which:

[0005] Figure 1 is an isometric view of the interior of a cargo area of an ambulance with an ambulance cot loading and unloading device embodying the invention being incorporated therein;

[0006] Figure 2 is a view similar to Figure 1, but with the ambulance cot loading and unloading device shifted from a stowed position in the interior of the cargo area as shown in Figure 1 to a deployed position;

[0007] Figure 3 is a view similar to Figure 1, but with the ambulance cot loading and unloading device removed;

[0008] Figure 4 is a schematic side illustration of the ambulance cot loading and unloading device in a deployed position thereof;

[0009] Figure 5 is a schematic side view of the ambulance cot loading and unloading device in a stowed and locked position inside the cargo area of the ambulance;

[0010] Figure 6 is a schematic side illustration similar to Figure 5, but in an unlocked condition;

[0011] Figure 7 is a schematic sectional view of the encircled area identified in broken lines in Figure 4;

[0012] Figure 8 is a side view of Figure 7 and illustrating a locking pin in a locked position;

[0013] Figure 9 is a view like Figure 8, but with the locking pin shifted to the unlocked position;

[0014] Figure 10 is an isometric view of the ambulance cot loading and unloading device in the stowed position;

[0015] Figure 11 is an isometric view of a fragment of the ambulance cot loading and unloading device with the trolley and elongate boom thereon located in the deployed position;

[0016] Figure 12 is a fragment of the interior-most end of the ambulance cot loading and unloading device;

[0017] Figure 13 is a schematic side illustration of the ambulance cot loading and unloading device;

[0018] Figure 14 is an illustration of the encircled area of Figure 13;

[0019] Figure 15 is like Figure 14, but with a locking device shifted to the locked position;

[0020] Figure 16 is a view like Figure 15, but with the locking device shifted to the unlocked position;

[0021] Figure 17 is a schematic side illustration of the trolley and elongate boom;

[0022] Figure 18 is a side illustration of an ambulance cot embodying the invention;

[0023] Figure 19 is a top illustration of a head end of the ambulance cot;

[0024] Figure 20 is a enlarged detail of an operative link between the ambulance cot and the trolley;

[0025] Figure 21 is a schematic illustration of the start of an ambulance cot loading sequence;

[0026] Figure 22 is a view similar to Figure 21, but with the trolley and elongate boom thereon moved to the deployed position ready to accept the ambulance cot thereon;

[0027] Figure 23 is a view similar to Figure 22, but with the ambulance cot engaged with the trolley;

[0028] Figure 24 is a view similar to Figure 23, but with the ambulance cot supported entirely on the trolley and associated elongate boom;

[0029] Figure 25 is a view similar to Figure 24, but with the ambulance cot base shifted to a position ready for insertion into the cargo area of the ambulance;

[0030] Figure 26 is a view similar to Figure 25, but with the ambulance cot and trolley moved partially into the cargo area of the ambulance;

[0031] Figure 27 is a view similar to Figure 26, but with the trolley and the ambulance cot inserted fully into the interior of the cargo area of the ambulance;

[0032] Figure 28 is an enlarged isometric of one end of the elongate guide track and the associated structure at the foot end of the ambulance cot;

[0033] Figure 29 is an enlarged side view of the operatively engaged elongate track and foot end of the ambulance cot;

[0034] Figure 30 is a side view illustrating the starting of an unloading sequence;

[0035] Figure 31 is a view similar to Figure 30, but with the ambulance cot having partially exited the cargo area;

[0036] Figure 32 is a view similar to Figure 31, but with the base portion of the ambulance cot oriented above the ground surface;

[0037] Figure 33 is a view similar to Figure 32, but with the base of the ambulance cot partially extended;

[0038] Figure 34 is a view similar to Figure 33, but with the base of the ambulance cot fully extended so that the wheels thereof are supported on the ground surface; and

[0039] Figure 35 is a view similar to Figure 34, but with the ambulance cot separated from the ambulance cot loading and unloading mechanism.

DETAILED DESCRIPTION

[0040] Figures 1 and 2 are both an isometric view of an ambulance cot loading and unloading device 10 embodying the invention and oriented on the floor surface 11 of a cargo area 12 of an ambulance 13. Figure 2 illustrates the ambulance cot loading and unloading device in a deployed position wherein a distal end 14 of an elongate boom 16 extends to a location outside of the cargo area 12. Inside a conventional cargo area 12 there is provided a plurality of floor mounted plates 17 (Figure 3). These plates are provided almost in a standard array in every cargo area of an ambulance so that the inventive ambulance cot loading and unloading device 10 can interface therewith.

[0041] More specifically, the ambulance cot loading and unloading device 10 includes an elongate guide track 15 consisting of a pair of elongate and parallel guide tubes 18 and 19 having a plurality of mounting plates interconnecting the guide tubes at multiple locations along the lengths thereof. The mounting plates 21 are spaced apart at an interval equal to the spacing between the floor plates 17 illustrated in Figure 3 so that the

mounting plates 21 can be utilized to secure the guide tubes 18 and 19 to the floor 11.

[0042] The ambulance cot loading and unloading device 10 includes a trolley 22 that is movable along the length of the guide tubes 18 and 19. The trolley includes a pair of tubular sleeves 23 and 24 respectively telescoped over the guide tubes 18 and 19 and a plate 26 (Figure 12) interconnecting the sleeves 23 and 24 together. A locking bar 27 is also connected to and extends between the sleeves 23 and 24 as is also illustrated in Figure 12. The trolley 22 also has a pair of upstanding bearing blocks 28 and 29 provided on the sleeves 23 and 24, respectively.

[0043] The rightmost mounting plate 21 in Figure 1 includes a plate 31 having an electrical connector 32 centrally mounted thereon, the electrical connector 32 being connected to an electrical system onboard the ambulance at a location beneath the floor plate 17. An electrical connector 33 is centrally provided on the locking bar 27 and is configured to mate with the electrical connector 32 when the trolley 22 reaches a location at the rightmost end of the guide tubes 18 and 19.

[0044] The elongate boom 16 is pivotally secured at one end to the bearing blocks 28 and 29 by any convenient structure providing an axle therefor. The axle has been generally indicated by the reference numeral 34. The elongate boom includes at the end thereof adjacent the axle 34 an upstanding hook-like configuration 36 wherein the opening into the hook-like configuration opens in a direction toward the distal end 14 of the elongate boom 16. Within the interior 37 of the hook-like configuration 36 there is provided two sets of toggle locking members 38 and 39, also shown in Figure 17. Each of the set of toggle levers 38 and 39 are pivotally

mounted on the elongate boom 16 and are configured to move in a manner suggested by Figures 14, 15 and 16. Each of the toggle levers 38 and 39 includes a torsion spring (not shown) urging the toggle levers 38 and 39 to the position illustrated in Figures 1 and 17. When an object is moved into the interior 37 of the hook-like configuration 36, as will be explained in more detail below, each of the toggle levers 38 and 39 will rotate counterclockwise so that the long legs 41 thereof will move to an upstanding position against the urging of the torsion spring. A latch 42 will move into a notch 43 provided on each toggle lever 38 and 39 to hold the long leg 41 in an upstanding position to block the exit of the object. A first manually engageable handle 44 is connected to the latch 42 by means of an elongate linkage 46 to facilitate a movement of the latch so that it is removable from the notch 43 to enable the torsion spring to return each of the toggle levers 38 and 39 to the position illustrated in Figure 17. A second manually engageable handle 45 is linked by a linkage member 50 (Figure 17) to the elongate linkage 46 to provide a second location from which to facilitate a movement of the latch 42 so that it is removed from the notch 43 to enable the torsion spring to return each of the toggle levers 38 and 39 to the position illustrated in Figure 17.

[0045] Adjacent the distal end 14 of the elongate boom 16 there is provided a depression 47 in which there is provided a set of electrical contacts 48. The electrical contacts 48 are electrically connected to the electrical contact 33 described above. The functionality of the set of electrical contacts 48 will be described in more detail below.

[0046] The elongate boom 16 is pivotal about the axle 34. An electrical jack mechanism 49 is connected to and

extends between the plate 26 and the underside of the elongate boom 16. The electrical jack mechanism 49 is extendable and contractible to effect a pivotal movement of the elongate boom in a manner that will be readily understood by those skilled in the art. A toggle switch 51 is mounted adjacent the distal end 14 and, upon manipulation, effects an extension or contraction of the jack mechanism 49 through the electrical connection provided between the switch 51 and a drive motor for the jack mechanism 49. If desired, an optional height sensor 52 (Figure 11) can be provided on the elongate boom 16 adjacent the distal end 14 so as to provide an indication of the distance between the underside of the elongate boom 16 and the ground surface.

[0047] A lug 53 is provided on the underside of the elongate boom 16 and is configured to be received into a receptacle 54 provided on the elongate guide track 15 defined by the guide tubes 18 and 19. It is desirable to orient the receptacle 54 on a mounting plate 21 so that upon reception of a lug 53 therein when the elongate boom 16 is lowered to the Figure 4 position, the trolley 22 will be incapable of movement relative to the elongate guide tubes 18 and 19. Upon a raising of the elongate boom 16 to the position illustrated in Figure 17, the lug 53 will be removed from the receptacle 54 to facilitate manual displacement of the trolley 22 along the length of the guide tubes 23 and 24.

[0048] In this particular embodiment, there is no drive mechanism for powering the trolley 22 along the length of the guide tubes 18 and 19. However, it is conceivable that such a drive mechanism could be provided and such is to be included within the scope of this invention.

[0049] As illustrated in Figure 10, there is provided a centrally disposed electrical connector 56 on a

mounting plate 57 oriented at an end of the guide track 15 remote from the electrical connector 32. The electrical connector 56 is connected to the onboard electrical system of the ambulance. When the trolley 22 is in the position illustrated in Figure 10, there is no electrical power being supplied to it. As a result, operation of the toggle switch 51 will not effect an operation of the jack mechanism 49. On the other hand, when the trolley 22 is moved leftwardly, there is provided an electrical connector 60 (Figure 12) on the trolley 22 which engages the electrical connector 56 so that electrical energy is supplied to the toggle switch 51 to effect a reverse in polarity of the drive motor for the jack mechanism 49 and to effect a corresponding raising and lowering of the elongate boom 16 only when the elongate boom is in the deployed position illustrated in Figures 2 and 11.

[0050] When the trolley 22 is in the Figure 10 position, it is normally locked to the elongate guide track 15 defined by the guide tubes 18 and 19. A locking mechanism 58 therefor is depicted in detail in Figures 5, 6, 7, 8 and 9. The locking mechanism 58 includes a pin 59 (Figure 8) which is supported for vertical movement. The pin includes a roller 61 rotatably secured to the bottom end of the pin 59. A plate 62 having a notch 63 therein is secured to the elongate guide track, such as to one of the mounting plates 21 so that the pin 59 can be moved vertically into and out of the notch 63. When the pin 59 is received in the notch 63 as depicted in Figure 8, the trolley 22 will be incapable of movement due to the interconnection of the pin 59 on the trolley to the guide track.

[0051] An object detector 66 is oriented in the interior 37 of the hook-like configuration 36 on the elongate boom 16. When an object is present in the

interior 37, the object detector 36 will be articulated downwardly as depicted in Figure 6. A linkage mechanism 67 is provided to effect a lifting of the pin 61 out of the notch 63 when the object detector 66 is moved to the Figure 6 position. On the other hand, when the trolley 22 is oriented intermediate the ends of the elongate guide track defined by the guide tubes 18 and 19, namely, is in the position illustrated in Figure 10, and no object is present in the interior 37 of the hook-like configuration 36, the pin will effect a locking of the trolley 22 in position so that the vehicle can be in motion without there being any corresponding inadvertent movement of the trolley relative to the elongate guide track 15.

[0052] When it is desired to move the trolley 22 leftwardly from the Figure 1 position to the Figure 2 position, the operator will grasp a handle configuration 68 to enable the elongate boom 16 to be easily grasped and pulled in a direction leftwardly in Figure 2 to draw the trolley 22 to the Figure 2 position. However, and before the trolley can be so moved, a removal of the locking pin 59 from the notch 63 is required. This is accomplished by manipulating a handle 69 oriented at the left end of the guide tube 16 as illustrated in Figure 10. The handle 69 is connected to an elongate rod 71 that extends through the interior of the guide tube 19 as depicted in Figures 5, 6 and 7. The elongate rod 71 is spring centered and is connected to a cam having an inclined cam surface 73 thereon facing the roller 61. Thus, as the handle 69 is pulled leftwardly, the elongate rod 71 will be pulled leftwardly against a spring urging to bring the cam surface 73 into engagement with the roller 61 to cause the roller 61 to roll up the ramp-like inclination 73 to draw the pin 59 from the notch 63.

[0053] An ambulance cot 80 (Figure 18) is configured to operatively load and unload from the ambulance cot loading and unloading device 10 described above. The particular construction of the ambulance cot 80 is disclosed in detail in U.S. Patent No. 5 537 700 and the subject matter thereof is incorporated herein by reference. The ambulance cot 80 described in the aforesaid patent has been modified at both the head end 81 and the foot end 82 and as described below. More specifically, the head end 81 has been modified to include a roller 83 rotatably mounted on an axis of rotation that extends perpendicular to a longitudinal axis of the ambulance cot 80. At the foot end 82, the auxiliary handle described in the aforementioned patent has been reconfigured as a foot end lift bar 84 (Figures 28 and 29) and additional hand grips 86 have been operatively connected to the foot end 82 of the ambulance cot 80 to facilitate attendant handling of the ambulance cot.

[0054] The ambulance cot 80 has been further modified to include a midsection connection piece 87 having a set of electrical contacts 88 thereon configured to interconnect with the set of electrical contacts 48 on the elongate boom 16. The connection 87 is also configured to snugly nest into the depression 87 in which the electrical contacts 48 is provided.

[0055] The ambulance cot 80 has been further modified to include a handle 91 interconnected by a linkage (not shown) to an abutment 92 oriented adjacent the connection 87. The abutment 92 is configured to engage the handle 44 on the elongate boom in response to manual manipulation of the handle 91. In this particular embodiment, the handle 91 is reciprocally supported in an elongate slot 93 provided at the foot end 82 of the ambulance cot 80 so that upon reciprocation of the handle

91 in the slot 93, the abutment 92 will also reciprocate to effect movement of the handle 44.

[0056] Adjacent the handle 86 at the foot end 82 of the cot 80 there is provided a three position toggle switch 94. Just forward of the foot end 82 there is provided a housing 96 in which is housed an electric motor 97 (Figure 18) and a rechargeable battery pack 98 for supplying power to the motor in a manner controlled by the aforementioned toggle switch 94. The battery pack 98 is configured to be easily exchanged without the necessity of tools and could be one or more batteries. The motor 97 could be a conventional DC drive motor for rotatably driving an input shaft of a hydraulic pump configured to be connected in fluid circuit with a hydraulic cylinder, the extendible and retractable rod of which is connected to the movable cross member on the cot 80 to facilitate a powered raising and lowering of the cot base 99. The battery 98 is capable of being charged when electrical power is supplied to the electrical contacts 88. In addition, the three position toggle switch 94 is capable of controlling the battery energy to the jack mechanism 49 to effect the raising and lowering movements of the elongate boom 16 only when the electrical contacts 48 and 88 are engaged as will be described in more detail below. The collapsible and extendable base 99 structure is virtually the same as the base described in the aforementioned patent and, therefore, further detailed discussion thereof is believed unnecessary.

[0057] Turning now to Figure 21, when it is desired to load the ambulance cot 80 into the cargo area 12 of an ambulance 13, it is necessary for the ambulance cot loading and unloading device 10 to be deployed so that the distal end 14 of the elongate boom 16 extends rearwardly from the cargo area and is lowered as depicted

in Figure 22. The aforesaid operation is accomplished by an attendant pulling the handle 69 in a rearward direction to cause the handle to impart a rearward movement of the elongate rod 71 as well as the cam 72 (Figures 8 and 9) to cause the inclined surface 73 on the cam 72 to engage the roller 61 to impart an upward lifting movement of the pin 59 from the notch 63. This operation unlocks the trolley 22 from the elongate guide track. Thereafter, the attendant can grasp the handle 68 at the distal end 14 of the elongate boom 16 to impart a rearward movement to the trolley 22 so that it shifts its location from the position illustrated in Figure 21 to the position illustrated in Figure 22. In the position illustrated in Figure 22, the electrical contact 60 on the trolley 22 (Figure 12) will interconnect with the electrical connector 56 so that electrical power from the ambulance 13 will be supplied to the toggle switch 51 to enable operative control to be provided to the electric motor for the jack mechanism 49 so as to facilitate an extension or retraction of the jack mechanism 49 to thereby effect a raising or a lowering of the elongate boom 16 relative to the trolley 22. Since, as depicted in Figure 22, it is desired to load the ambulance cot 80 into the cargo area 12 of the ambulance 13, the toggle switch 51 will effect a lowering of the elongate boom 16 to a location wherein the lug 53 enters the receptacle 54 on the elongate guide track to effectively lock and hold the trolley 22 in place while the ambulance cot 80 is being loaded.

[0058] Next, the ambulance cot 80 is moved by the attendant and on its wheel supported base 99 until the roller at the head end of the ambulance cot engages the inclined upper surface of the elongate boom 16 and rolls into the interior 37 of the hook-like configuration 36. At this point in time, the lead support wheel 101 moves

into engagement and rests on the floor surface 11 of the cargo area 12 of the ambulance 13 as depicted in Figure 23. As the roller 83 enters the interior 37 of the hook-like configuration 36, the sets of toggle levers 38 and 39 will be moved clockwise from the position illustrated in Figure 17 to a position wherein the long legs 41 (Figure 17) become upright to effect a holding of the roller 83 into the interior space 37 of the hook-like configuration 36. The latch 42 will be received in a notch 43 to hold the toggle levers 39 in the locked position whereat the long leg 41 extends in a vertically upright manner. At this point in time, the ambulance cot 80 is now locked at the head end 81 thereof to the ambulance cot loading and unloading device 10. In addition, the roller 83 has depressed the object detector 66 inside the interior 37 of the hook-like configuration to effect a raising through the linkage 67 of the locking pin 61. The toggle lever switch 94 is next operated to change its state from a "neutral" state (Figure 18) to a "retract base" state to effect a battery powered operation of the motor 97 to effect a contracting of the base 99 as depicted in Figure 24. Since the spacing between the hook-like configuration 36 and the depression 47 on the elongate boom 16 is equal to the spacing between the roller 83 and the connection piece 87 on the cot 80 as the base 99 retracts, the ambulance cot 80 will initially be lowered about a pivot axis defined by the roller 83 received in the hook-like configuration 36 until the connection piece 87 is received in the depression 47 in the elongate boom 16 so that the sets of contacts 88 and 48 come into contact with each other. At this moment, the "retract base" state of the toggle switch 94 usurps the toggle switch 51 so that the toggle switch 94 in the "retract base" position effects an extension of the jack mechanism 49 and thence a raising

of the elongate boom 16 from the Figure 24 position to the Figure 25 position. The toggle switch 94 remains in the "retract base" condition until the base 99 is fully collapsed and all six wheels on the ambulance cot 80 are aligned with the floor 11 in the cargo area 12 of the ambulance 13. Thereafter, the attendant can simply push on the foot end 82 of the ambulance cot 80 to facilitate movement of the ambulance cot 80 and the interconnected trolley 22 through the position illustrated in Figures 26 to the position illustrated in Figure 27. During this transitional movement, the electrical contacts 56 and 60 become disconnected and when the trolley 22 reaches the position illustrated in Figure 27, the electrical contacts 32 and 33 will interconnect so that the battery 98 onboard the ambulance cot 80 will be recharged by the electrical system onboard the ambulance 13 and through the electrical connection provided by the interconnected set of contacts 48 and 88. As the trolley 22 moves toward its final location illustrated in Figure 27, the locking bar 27 (Figure 12) will be operatively received in a trolley locking mechanism 102. The trolley locking mechanism 102 consists of a pair of laterally spaced hook-like configurations 103 which each include an interior space 104 facilitating reception of the locking bar 27 on the trolley 22. A toggle lever 106 is associated with each hook-like configuration 103 and rotate against the urging of a not illustrated torsion spring so that the horizontal leg illustrated in Figure 12 will be shifted to a vertically upright position to hold the locking bar 27 in place. The change in state of the toggle levers 106 is illustrated in Figures 14, 15 and 16.

[0059] A foot end ambulance cot locking system 107 is connected to the elongate guide track 18, 19 (Figure 10) and is identical in form to the trolley locking mechanism

102. That is, each of the foot end ambulance cot locking mechanism 107 includes a pair of laterally spaced hook-like configurations 103 and a rotatable toggle lever 106 urged by a torsion spring to the position illustrated in Figure 10. Thus, as the cot lifting bar 84 (Figure 28) is moved rightwardly, the lifting bar 84 will effect a pivotal movement of the set of toggle levers 106 in the manner illustrated in Figures 14, 15 and 16. A latch mechanism 108 operatively engaging the toggle levers 106 at all four locations will effect a locking of the toggle levers 106 in the elevated position illustrated in Figure 15 in manner similar to the operative arrangement between the latch 42 and the set of toggle levers 38 and 39 described above. The ambulance cot 80 is now secured inside the cargo area 12 of the ambulance 13 at four spaced locations defined by the spaced hook-like configurations 103 illustrated in Figure 10. In addition, the head end 81 of the ambulance cot 80 is secured to the trolley 22 by the hook-like configuration 36 and associated sets of toggle levers 38 and 39.

[0060] Referring now to Figure 30, when it is desired to remove the ambulance cot 80 from the cargo area 12 of the ambulance 13, the handle 69 is pushed forwardly against the force of the not illustrated centering spring as depicted in Figures 14, 15 and 16 to cause the elongate rod 71 to unlatch the latches 108 to cause the torsion springs to move the toggle levers 106 from the Figure 15 position to the Figures 14 and 16 positions to thereby release the lift bar 84 and the locking bar 27 therefrom. Thereafter, the attendant can pull on the lift bar 84 or the handles 86 at the foot end 82 of the ambulance cot 80 to effect a movement of not only the ambulance cot 80 but also the trolley 22 from the position illustrated in Figure 30 through the position illustrated in Figure 31 to the position illustrated in

Figure 32. In this position, the set of contacts 56 and 60 reengage so that battery power from the battery 98 onboard the ambulance cot is interconnected to the toggle switch 94 onboard the ambulance cot to thereby enable the attendant to manipulate the switch to the "extend base" position to operatively simultaneously cause the jack mechanism 49 to be operated to retract and lower the elongate boom 16 from the position illustrated in Figure 32 to the position illustrated in Figure 33 and an extension of the base 99 from its fully retracted position illustrated in Figure 32 and as depicted in Figure 33. Even though the elongate boom 16 has reached its lowermost position as depicted in Figure 33, the attendant's continued operation of the toggle switch 94 by holding it in its "extend base" state, the base 99 will continue to extend until all four wheels are in engagement with the ground as illustrated in Figure 34 and the connection piece 87 is raised out of the depression 47 in the elongate boom 16 to decouple the electrical contacts 48 and 88. At this point in the ambulance cot 80 removal sequence, the wheels 101 at the head end 81 of the ambulance cot 80 are still in engagement with the floor 11 of the cargo area 12 of the ambulance 13 and as depicted in Figure 34. Thereafter, the handle 91 at the foot end 82 of the ambulance cot 80 is slid forwardly in the elongate slot 93 so that the abutment 92 interconnected therewith will abut the handle 44 on the elongate boom 44 to effect an unlatching of the set of toggle levers 38, 39 to release the roller 83 from the hook-like configuration 36 on the trolley 22. In the alternative, the handle 45 can be manually manipulated to free the ambulance cot 80 from the trolley 22.

[0061] The ambulance cot 80 is now freed from the ambulance cot loading and unloading device 10 and is

capable of moving freely away from the ambulance on the wheel supported base 99 as depicted in Figure 35.

[0062] Although a particular preferred embodiment of the invention has been disclosed in detail for illustrative purposes, it will be recognized that variations or modifications of the disclosed apparatus, including the rearrangement of parts, lie within the scope of the present invention. For example, all or selected ones of the electrical contacts could be replaced with electrical devices, such as proximity type switches or radio frequency activated devices where actual contact between components is not required in order to effect the desired electrical communication. Additionally, during loading, the boom and cot can be lifted before the base is collapsed. Similarly, during unloading, the base can be fully deployed before the boom is lowered.

What is claimed is:

1. A combination of an ambulance cot having a wheel supported base and an ambulance cot loading and unloading device, especially for ambulances, comprising:

an elongate guide track configured for mounting to a fixed surface of a cargo area on said ambulance;

a trolley supported for movement relative to said elongate guide track between first and second positions, said trolley being configured to move to a location adjacent an access opening to an interior of the cargo area when said trolley is in said first position and is additionally configured to move to a location spaced from said access opening when said trolley is not in said first position;

a connection mechanism on said trolley configured to interconnect and securely hold said ambulance cot on said trolley;

an energy consumer on said trolley for effecting, while said ambulance cot is coupled by said connection mechanism to said trolley, at least one of a vertical movement of said ambulance cot to operatively align the wheels of said wheel supported base thereof with a floor surface of said cargo area prior to a loading of said ambulance cot into said cargo area and a vertical movement of said ambulance cot after an unloading of said ambulance cot from said cargo area to facilitate engagement of the wheels of said wheel supported base with a ground surface; and

a first device on said ambulance cot configured to activate said energy consumer when said connection mechanism is interconnected to and securely holds said ambulance cot on said trolley.

2. The combination according to Claim 1, wherein said trolley includes an elongate boom secured to said trolley and configured to extend to a location outside of the cargo area, said elongate boom being configured for vertical movement relative to said trolley in order to accommodate varying ambulance cot loading and unloading conditions; and

wherein said energy consumer includes a motor for effecting, when said motor is operated, said vertical movement of said elongate boom.

3. The combination according to Claim 2, wherein a manually manipulatable first switch is provided on said elongate boom and is interconnected between an energy source onboard said ambulance and said energy consumer for facilitating an attendant controlled reversal in the energy of said energy source supplied to said motor to effect movement of said elongate boom in attendant selected vertical directions.

4. The combination according to Claim 3, wherein said manually manipulatable first switch is provided on said elongate boom adjacent a distal end thereof.

5. The combination according to Claim 4, wherein said manually manipulatable first switch provided on said elongate boom is configured to be usurped by the functionality of said first device on said ambulance cot.

6. The combination according to Claim 5, wherein said first device is provided on said ambulance cot adjacent a foot end thereof, a head end of said ambulance cot being configured to operatively couple to said connection mechanism.

7. The combination according to Claim 3, wherein said ambulance cot includes a collapsible and an extendable base and a patient support deck mounted on said base and an electrically operable motor and interconnected battery onboard said ambulance cot for effecting, when said motor is electrically operated, a collapsing or an extending of said base.

8. The combination according to Claim 7, wherein said trolley includes a second device connected in circuit with said first switch; and

wherein said ambulance cot includes a third device configured to communicate with said second device when said ambulance cot is securely held on said trolley and only when said base is collapsed from an extended position thereof.

9. The combination according to Claim 8, wherein said first device on said ambulance cot includes a manually manipulatable second switch interconnected between said battery and said electrical motor for facilitating an attendant controlled reversal in polarity of the electrical energy supplied to said electrical motor to effect a collapsing or an extending of said base of said ambulance cot and independent of the electrical communication between said second and third devices.

10. The combination according to Claim 7, wherein said trolley includes an elongate boom configured for vertical movement relative to said trolley in response to activation of said energy consumer, said ambulance cot includes a second device and said trolley includes a third device, said second and third devices being configured to communicate when said ambulance cot is

securely held on said trolley and only when said base is collapsed from an extended position thereof; and

wherein said first device on said ambulance cot is a manually manipulatable second switch configured to usurp the functionality of said manually manipulatable first switch when said third device communicates with said second device so that the attendant will be able to control the reversal in the energy supplied to said energy consumer to effect movement of said elongate boom in attendant selected vertical directions by manual manipulation of said manually manipulatable second electrical switch.

11. The combination according to Claim 10, wherein said manually manipulatable second switch is provided on said ambulance cot adjacent a foot end thereof, a head end of said ambulance cot being configured to operatively couple to said elongate boom and said first ambulance cot fastening assembly.

12. The combination according to Claim 10, wherein said elongate guide track includes a fourth device adjacent an end of said elongate guide track corresponding to said first position of said trolley thereon, said fourth device being connected to an energy source onboard said ambulance, said trolley including a fifth device configured to communicate with said fourth device only when said trolley is oriented at said end of said elongate guide track so that said elongate boom can be moved vertically only when said trolley is oriented at said end.

13. The combination according to Claim 1, wherein said trolley includes an elongate boom secured to said trolley and configured to extend to a location outside of the cargo area when said trolley is in said first position, said elongate boom being configured for vertical movement relative to said trolley in order to accommodate varying ambulance cot loading and unloading conditions; and

wherein said trolley is freely movable lengthwise of said elongate guide track when said elongate boom is elevated, said trolley being fixedly locked to said elongate guide track in response to said elongate boom being placed into a lowered position.

14. The combination according to Claim 1, wherein said trolley is configured for free movement lengthwise of said elongate guide track.

15. The combination according to Claim 1, wherein said elongate guide track includes a second device connected in circuit to an energy source onboard said ambulance, said second device being configured to communicate with a third device separate from said elongate guide track.

16. The combination according to Claim 15, wherein said third device is provided on said trolley.

17. The combination according to Claim 16, wherein said second device is oriented adjacent an end of said elongate guide track corresponding to said second position of said trolley thereon so that said second device will communicate with said third device when said trolley is in said second position thereon.

18. The combination according to Claim 17, wherein said ambulance cot includes a fourth device connected in circuit with said battery; and

wherein said fourth device is configured to communicate with said third device when said ambulance cot is securely held on said trolley to facilitate a recharging of said battery utilizing energy supplied by said energy source onboard said ambulance.

19. An ambulance cot support arrangement, especially for ambulances, comprising:

an elongate guide track configured for mounting to a fixed surface of a cargo area on said ambulance;

a trolley supported for movement relative to said elongate guide track between first and second positions, said trolley being configured to move to a location adjacent an access opening to an interior of the cargo area when said trolley is in said first position and is additionally configured to additionally move to a location spaced from said access opening when said trolley is not in said first position; and

an ambulance cot fastening assembly mounted on said trolley and configured to releasably securely hold an ambulance cot thereon in all positions of said trolley on said elongate guide track.

20. The ambulance cot support arrangement according to Claim 19, wherein said trolley includes an elongate boom secured to said trolley and configured to extend to a location outside of the cargo area when said trolley is in said first position, said elongate boom being configured for vertical movement relative to said trolley in order to accommodate varying ambulance cot loading and unloading conditions.

21. The ambulance cot support arrangement according to Claim 20, wherein said elongate boom is secured to said trolley for movement about a pivot axis that extends perpendicular to a theoretical vertically upright plane containing a longitudinal axis of said elongate guide track.

22. The ambulance cot support arrangement according to Claim 19, wherein said elongate guide track includes a first device connected in circuit to an energy source onboard said ambulance, said first device being configured to electrically communicate with a second device separate from said elongate guide track.

23. The ambulance cot support arrangement according to Claim 22, wherein said second device is provided on said trolley.

24. The ambulance cot support arrangement according to Claim 23, wherein said first device is oriented adjacent an end of said elongate guide track corresponding to said second position of said trolley thereon so that said second device will communicate with said first device when said trolley is in said second position thereon.

25. The ambulance cot support arrangement according to Claim 19, wherein said trolley includes an elongate boom secured to said trolley and configured to extend to a location outside of the cargo area when said trolley is in said first position, said elongate boom being configured for vertical movement relative to said trolley in order to accommodate varying ambulance cot loading and unloading conditions; and

wherein said trolley includes an onboard motor for effecting, when said motor is operated, said vertical movement of said elongate boom; and

wherein a manually manipulatable first switch is interconnected between said motor and an energy source onboard said ambulance for facilitating an attendant controlled reversal in energy supplied to said motor to effect movement of said elongate boom in attendant selected vertical directions.

26. The ambulance cot support arrangement according to Claim 25, wherein said manually manipulatable first switch is provided on said elongate boom adjacent a distal end thereof.

27. The ambulance cot support arrangement according to Claim 19, wherein said elongate guide track includes a first device adjacent an end of said elongate guide track corresponding to said first position of said trolley thereon, said first device being connected to an energy source onboard said ambulance, said trolley including a second device configured to communicate with said first device only when said trolley is oriented at said end of said elongate guide track so that said elongate boom can be moved vertically only when said trolley is oriented at said end.

28. The ambulance cot support arrangement according to Claim 19, wherein said trolley includes an elongate boom secured to said trolley and configured to extend to a location outside of the cargo area when said trolley is in said first position, said elongate boom being configured for vertical movement relative to said trolley in order to accommodate varying ambulance cot loading and unloading conditions; and

wherein said trolley is freely movable lengthwise of said elongate guide track when said elongate boom is elevated, said trolley being fixedly locked to said elongate guide track in response to said elongate boom being placed into a lowered position.

29. The ambulance cot support arrangement according to Claim 19, wherein said ambulance cot fastening assembly includes a second ambulance cot fastening assembly configured with a trolley fastening assembly and said trolley is also additionally configured for a releasable coupling to said trolley fastening assembly only when said trolley is in said second position.

30. The ambulance cot support arrangement according to Claim 29, wherein said trolley includes a first horizontal bar that extends along an axis that is perpendicular to a longitudinal axis of said elongate guide track; and

wherein said trolley fastening assembly includes a first pair of laterally spaced hook members configured to latch onto said first horizontal bar at laterally spaced locations thereon.

31. The ambulance cot support arrangement according to Claim 30, wherein said second ambulance cot fastening assembly is additionally provided on said elongate guide track at a location adjacent a position corresponding to said first position of said trolley, said second ambulance cot fastening assembly including a second pair of laterally spaced hook members.

32. The ambulance cot support arrangement according to Claim 31, wherein a manually manipulatable release lever is provided on said elongate guide track adjacent a location corresponding to said trolley being in said first position for effecting a simultaneous unlatch of said first and second pairs of said hook members.

33. The ambulance cot support arrangement according to Claim 19, wherein said ambulance cot fastening assembly includes a second ambulance cot fastening assembly provided on said elongate guide track at a location adjacent a position corresponding to said first position of said trolley, said second ambulance cot fastening assembly including a first pair of laterally spaced hook members.

34. The ambulance cot support arrangement according to Claim 19, wherein said trolley includes an elongate boom and a trolley position locking device for locking said trolley to said elongate guide track at a location intermediate said first and second positions of said trolley on said elongate guide track whereat a distal end of said elongate boom is oriented adjacent an end of said elongate guide track corresponding to said first position of said trolley.

35. The ambulance cot support arrangement according to Claim 34, wherein a handle is provided on said distal end of said elongate boom.

36. The ambulance cot support arrangement according to Claim 35, wherein a manually manipulatable release lever is provided on said elongate guide track adjacent a location corresponding to said trolley being in said first position and is configured to effect an unlocking of said trolley from said elongate guide track when said trolley is in said intermediate location.

37. The ambulance cot support arrangement according to Claim 19, wherein said trolley includes an ambulance cot detector configured for detecting a presence or absence of an ambulance cot held to said trolley by said ambulance cot fastening assembly, said ambulance cot detector being additionally configured to prevent a locking of said trolley to said elongate guide track by said trolley position locking device.

38. The ambulance cot support arrangement according to Claim 19, wherein said trolley includes an elongate boom secured to said trolley for vertical movement relative to said trolley in order to accommodate varying ambulance cot loading and unloading conditions; and wherein said elongate boom includes a sensing device for monitoring the distance of said elongate boom from a ground surface on which said ambulance is supported in all vertically adjusted positions of said elongate boom.

39. The ambulance cot support arrangement according to Claim 19, wherein said trolley is freely manually movable lengthwise of said elongate guide track between said first and second positions thereof.

40. An ambulance cot support arrangement, especially for ambulances, comprising:

an elongate guide track configured for mounting to a fixed surface of a cargo area on said ambulance;

a trolley supported for movement relative to said elongate guide track between first and second positions, said trolley being configured to move to a location adjacent an access opening to an interior of the cargo area when said trolley is in said first position and is additionally configured to additionally move to a location spaced from said access opening when said trolley is not in said first position; and

an ambulance cot fastening assembly configured to securely hold said trolley and said ambulance cot relative to a fixed surface of the cargo area only when said trolley is in said second position.

41. The ambulance cot support arrangement according to Claim 40, wherein said trolley includes an elongate boom secured to said trolley for vertical movement relative to said trolley in order to accommodate varying ambulance cot loading and unloading conditions.

42. The ambulance cot support arrangement according to Claim 41, wherein said elongate boom is secured to said trolley for movement about a pivot axis that extends perpendicular to a theoretical vertically upright plane containing a longitudinal axis of said elongate guide track.

43. The ambulance cot support arrangement according to Claim 40, wherein said elongate guide track includes a first device connected in circuit to an energy source onboard said ambulance, said first device being configured to communicate with a second device separate from said elongate guide track.

44. The ambulance cot support arrangement according to Claim 43, wherein said second device is provided on said trolley.

45. The ambulance cot support arrangement according to Claim 44, wherein said first device is oriented adjacent an end of said elongate guide track corresponding to said second position of said trolley thereon so that said second device will communicate with said first device when said trolley is in said second position thereon.

46. The ambulance cot support arrangement according to Claim 40, wherein said ambulance cot fastening assembly is additionally configured with a trolley fastening assembly and said trolley is also additionally configured for a releasable coupling to said trolley fastening assembly only when said trolley is in said second position.

47. The ambulance cot support arrangement according to Claim 46, wherein said trolley includes a first horizontal bar that extends along an axis that is perpendicular a longitudinal axis of said elongate guide track; and

wherein said trolley fastening assembly includes a first pair of laterally spaced hook members configured to

latch onto said first horizontal bar at laterally spaced locations thereon.

48. The ambulance cot support arrangement according to Claim 47, wherein said ambulance cot fastening assembly is provided on said elongate guide track at a location adjacent a position corresponding to said first position of said trolley and includes a second pair of laterally spaced hook members.

49. The ambulance cot support arrangement according to Claim 48, wherein a manually manipulatable release lever is provided on said elongate guide track adjacent a location corresponding to said trolley being in said first position for effecting a simultaneous unlatch of said first and second pairs of said hook members.

50. The ambulance cot support arrangement according to Claim 40, wherein said ambulance cot fastening assembly is provided on said elongate guide track at a location adjacent a position corresponding to said first position of said trolley, said ambulance cot fastening assembly including a first pair of laterally spaced hook members.

51. The ambulance cot support arrangement according to Claim 40, wherein said trolley includes an elongate boom and a trolley position locking device for locking said trolley to said elongate guide track at a location intermediate said first and second positions of said trolley on said elongate guide track whereat a distal end of said elongate boom is oriented adjacent an end of said elongate guide track corresponding to said first position of said trolley.

52. The ambulance cot support arrangement according to Claim 51, wherein a handle is provided on said distal end of said elongate boom.

53. The ambulance cot support arrangement according to Claim 40, wherein said trolley includes an elongate boom secured to said trolley and configured to extend to a location outside of the cargo area when said trolley is in said first position, said elongate boom being configured for vertical movement relative to said trolley in order to accommodate varying ambulance cot loading and unloading conditions; and

wherein said trolley includes an onboard motor for effecting, when said motor is operated, said vertical movement of said elongate boom; and

wherein a manually manipulatable first switch is interconnected between said motor and an energy source onboard said ambulance for facilitating an attendant controlled reversal in energy supplied to said electrical motor to effect movement of said elongate boom in attendant selected vertical directions.

54. The ambulance cot support arrangement according to Claim 53, wherein said manually manipulatable first switch is provided on said elongate boom adjacent a distal end thereof.

55. The ambulance cot support arrangement according to Claim 54, wherein said elongate guide track includes a first device adjacent an end of said elongate guide track corresponding to said first position of said trolley thereon, said first device being connected to an energy source onboard said ambulance, said trolley including a second device configured to communicate with said first device only when said trolley is oriented at said end of

said elongate guide track so that said elongate boom can be moved vertically only when said trolley is oriented at said end.

56. The ambulance cot support arrangement according to Claim 40, wherein said trolley includes an elongate boom secured to said trolley and configured to extend to a location outside of the cargo area when said trolley is in said first position, said elongate boom being configured for vertical movement relative to said trolley in order to accommodate varying ambulance cot loading and unloading conditions; and

wherein said trolley is freely movable lengthwise of said elongate guide track when said elongate boom is elevated, said trolley being fixedly locked to said elongate guide track in response to said elongate boom being placed into a lowered position.

57. The ambulance cot support arrangement according to Claim 56, wherein a manually manipulatable release lever is provided on said elongate guide track adjacent a location corresponding to said trolley being in said first position and is configured to effect an unlocking of said trolley from said elongate guide track when said trolley is in said intermediate location.

58. The ambulance cot support arrangement according to Claim 40, wherein said trolley includes an elongate boom secured to said trolley and configured to extend to a location outside of the cargo area when said trolley is in said first position, said elongate boom being configured for vertical movement relative to said trolley in order to accommodate varying ambulance cot loading and unloading conditions; and

wherein said elongate boom includes a sensing device for monitoring the distance of said elongate boom from a ground surface on which said ambulance is supported in all vertically adjusted positions of said elongate boom.

59. The ambulance cot support arrangement according to Claim 40, wherein said trolley is freely manually movable lengthwise of said elongate guide track between said first and second positions thereof.

60. A method of loading a wheel supported ambulance cot having a collapsible and extendable base thereon from an ambulance, comprising the steps of:

deploying a trolley to a load position;

moving said ambulance cot toward and into coupled engagement with said trolley;

collapsing said base to effect said ambulance cot being supported entirely on said trolley; and

moving trolley and ambulance cot coupled thereto into said cargo area of said ambulance.

61. The method according to Claim 60, wherein said deploying step includes the step of deploying said trolley to a position spaced vertically above a ground surface on which said ambulance is supported and the step of tilting an elongate boom on said trolley from a position parallel to the floor surface of said cargo area downwardly toward the ground surface.

62. The method according to Claim 61, wherein said collapsing step additionally includes the step of raising the elongate boom to the position above the floor surface of said cargo area and with said ambulance cot coupled thereto.

63. The method according to Claim 62, wherein said raising step and said base collapsing step occur simultaneously after said wheels disengage from the ground surface.

64. A method of unloading a wheel supported ambulance cot having a collapsible and extendable base thereon, comprising the steps of:

moving an ambulance cot with a collapsed base coupled to a trolley out of a cargo area of said ambulance so that said ambulance cot is supported by said trolley above a ground surface on which said ambulance is supported;

extending said base so that said wheels engage said ground surface and effect a support of said ambulance cot on said wheels; and

moving said ambulance cot on said wheels in a direction until said ambulance cot is generally free of interference from said trolley.

65. The method of unloading a wheel supported ambulance cot according to Claim 64, wherein said extending step includes the step of tilting an elongate boom on said trolley from a position above the floor surface of said cargo area downwardly toward the ground surface.

66. The method of unloading a wheel supported ambulance cot according to Claim 65, wherein said extending step and said tilting step occur simultaneously during an extension of said base, said tilting step terminating when said wheels engage said ground surface.

67. An ambulance cot configured for reception into a cargo area of an ambulance, comprising:

a wheel supported base;

a patient support deck mounted on said wheel supported base;

an energy consumer mechanism for effecting a varying of the spacing between said wheel supported base and said patient support deck;

a rechargeable first energy source onboard said ambulance cot configured for supplying energy to said energy consumer mechanism to effect a change in said spacing, said rechargeable first energy source including a remotely located connection device onboard the ambulance cot configured for connecting the energy of said rechargeable first energy source to a second energy source to effect a recharging of said first energy source.

68. The ambulance cot according to Claim 67, wherein said rechargeable first energy source is a battery and said energy consumer mechanism is an electrically operable motor.

69. The ambulance cot according to Claim 67, wherein said rechargeable first energy source includes a switch interconnected between said rechargeable first energy source and said energy consumer mechanism for facilitating an attendant controlled operation of energy supplied to said energy consumer mechanism to effect a change of said spacing.

70. The ambulance cot according to Claim 69, wherein said rechargeable first energy source is a battery and said energy consumer mechanism is an electrically operable motor.

71. The ambulance cot according to Claim 67, wherein said remotely located connection device is fixedly located on at least one of said patient support deck and said wheel supported base.

72. An ambulance cot configured for reception into a cargo area of an ambulance, comprising:

a wheel supported base;

a patient support deck frame mounted on said wheel supported base; and

docking structure onboard said ambulance cot configured for connection to a cot loading and unloading device provided on an ambulance.

73. The ambulance cot according to Claim 72, wherein said docking structure includes at least two separate docking structures spaced lengthwise of the ambulance cot from each other.

74. The ambulance cot according to Claim 73, wherein one of said two docking structures is located adjacent a head end of the ambulance cot and the other docking structure is located intermediate the head end and a foot end thereof.

75. The ambulance cot according to Claim 74, wherein said two separate docking structures are oriented on said patient support deck frame.

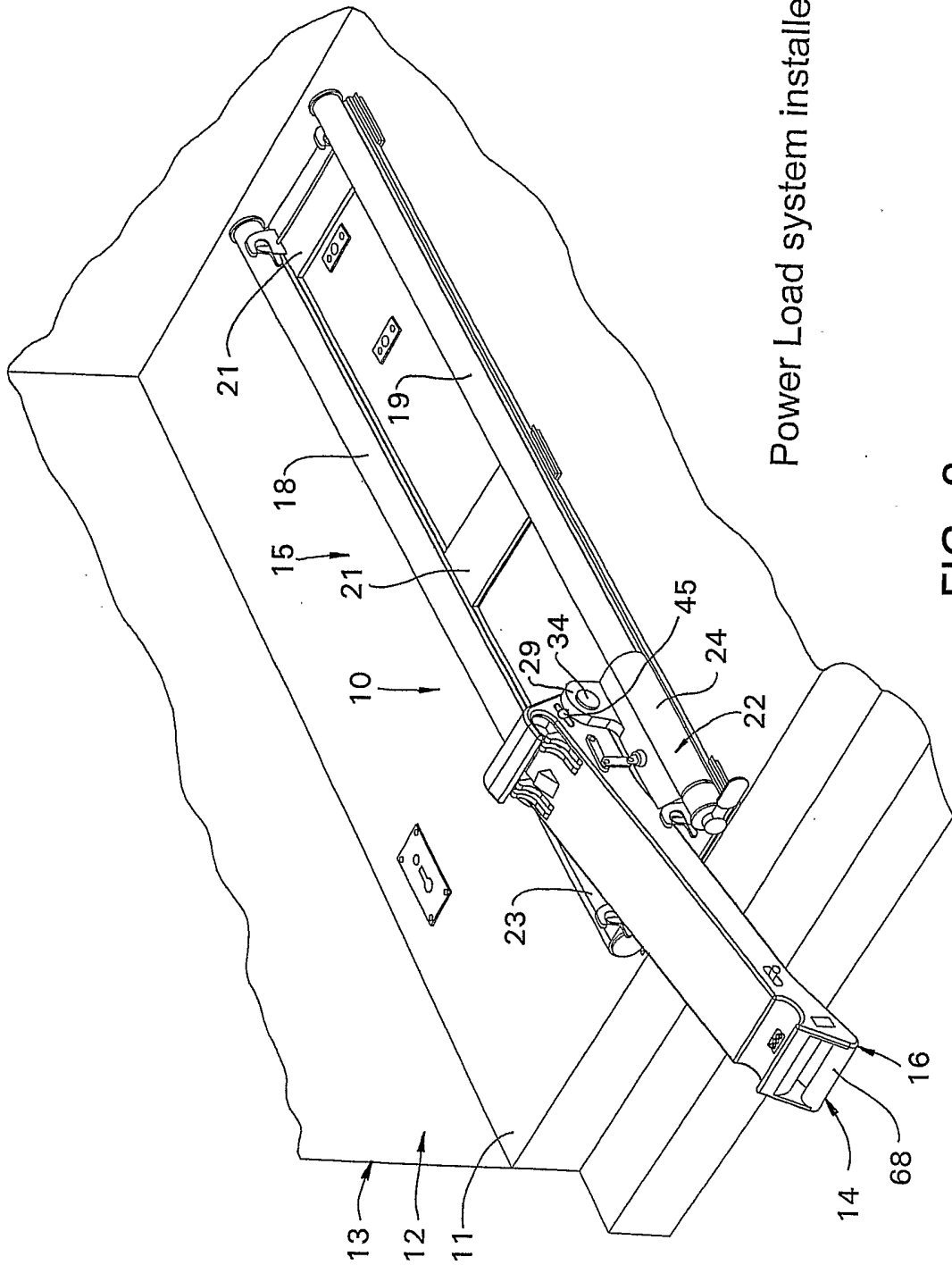

Power Load system installed and lowered

FIG. 2

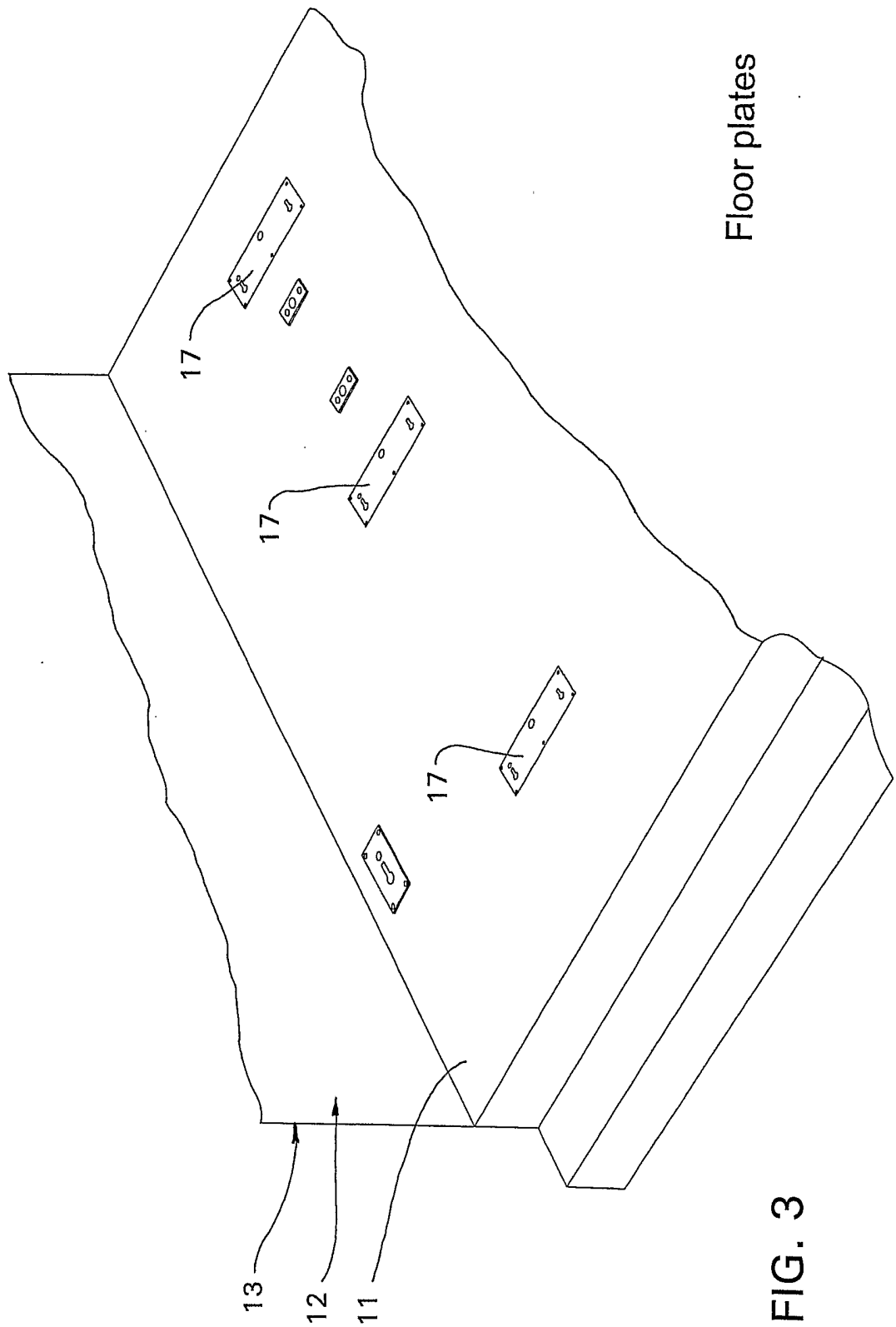

Floor plates

FIG. 3

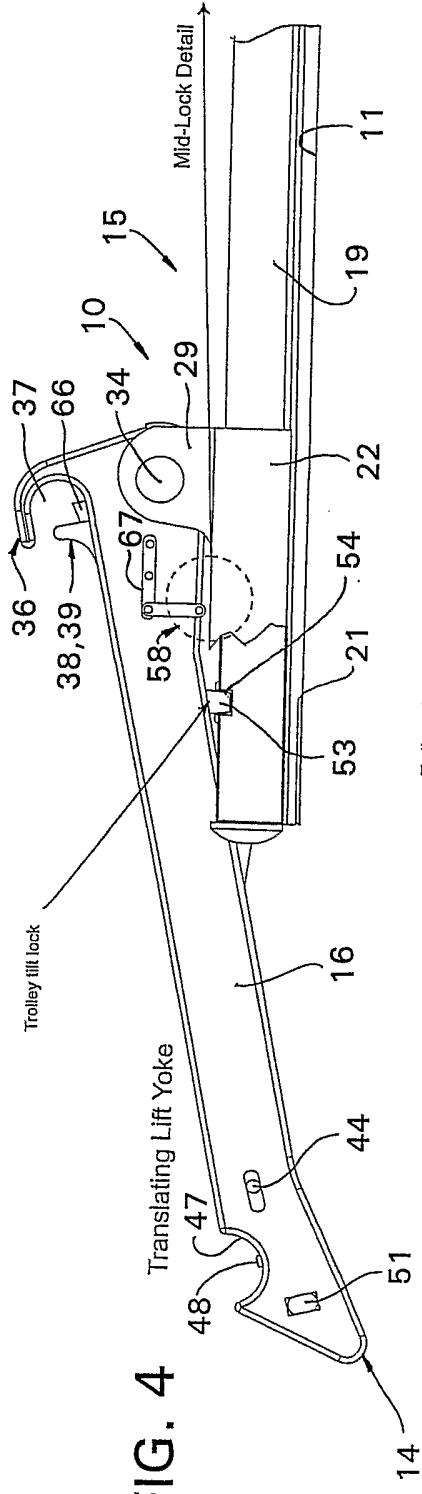

FIG. 4

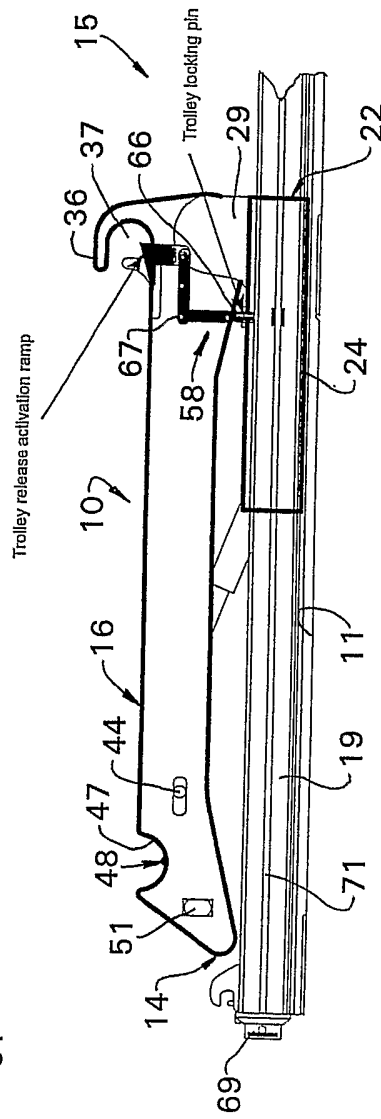

FIG. 5

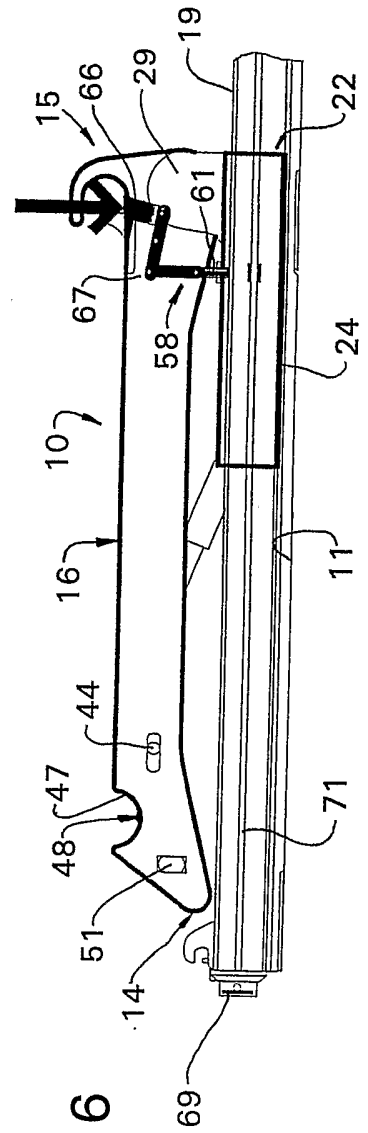

FIG. 6

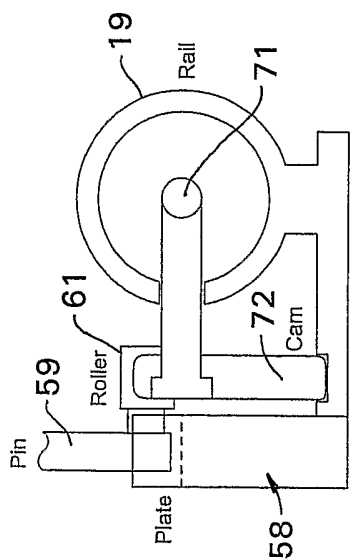

FIG. 7

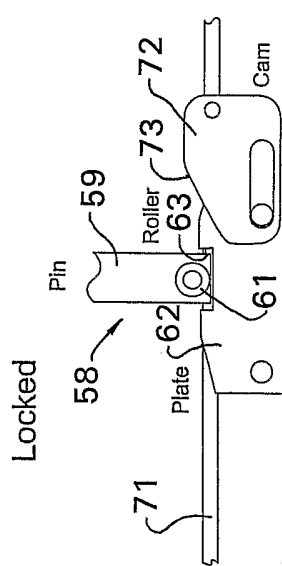

FIG. 8

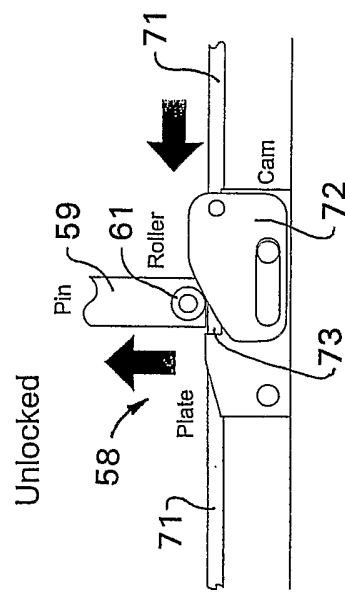

FIG. 9

6/24

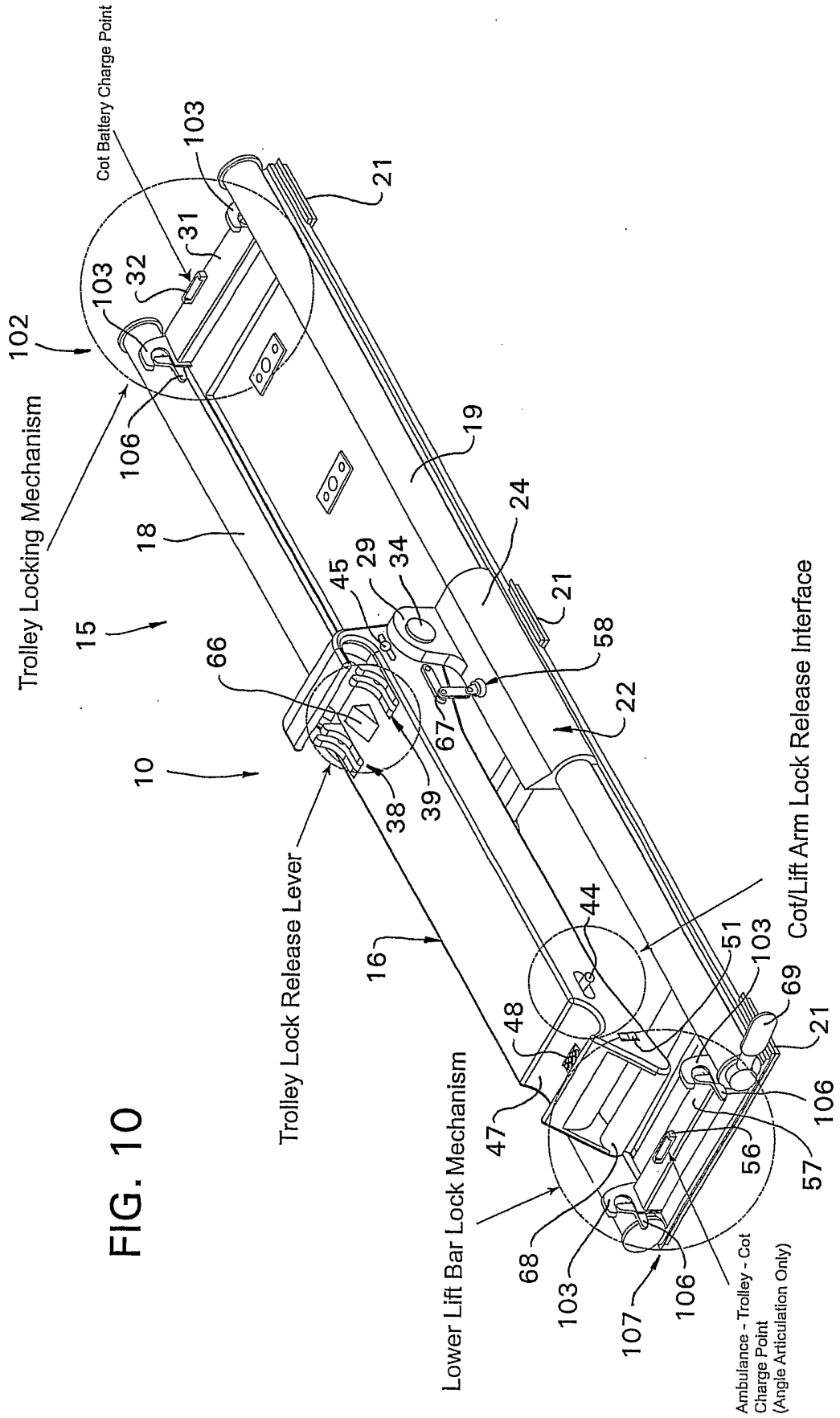

FIG. 10

7/24

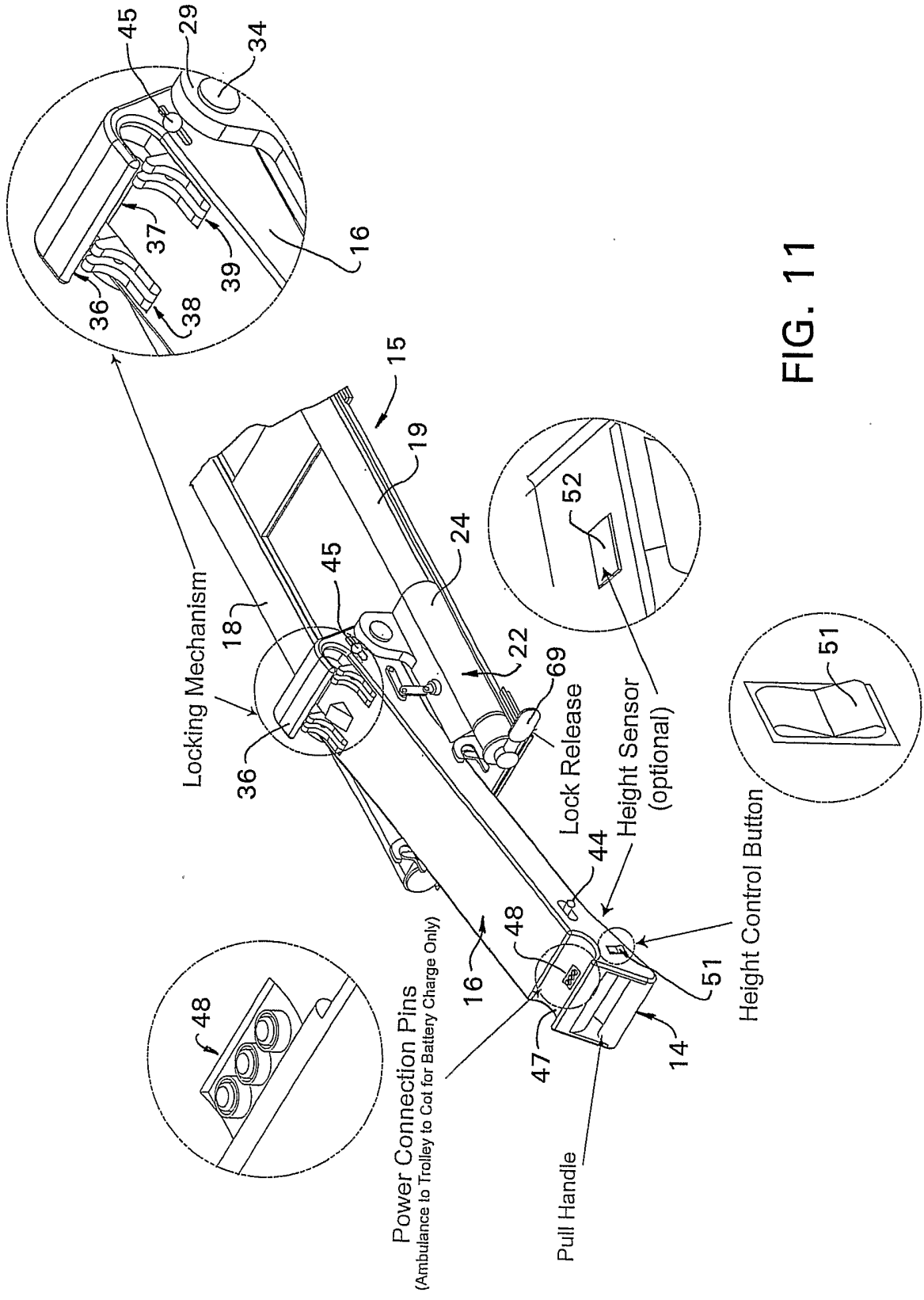
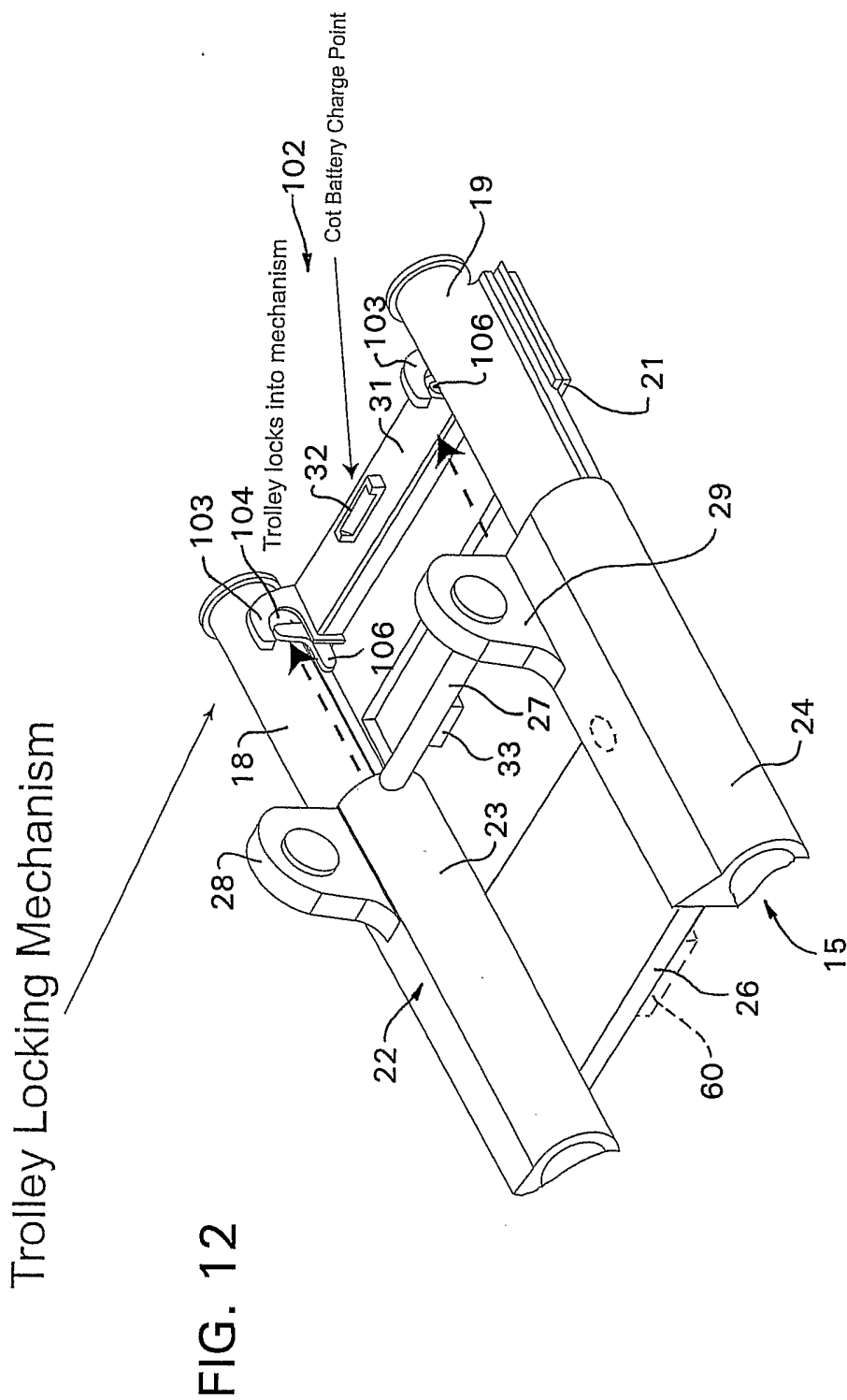

FIG. 11

8/24



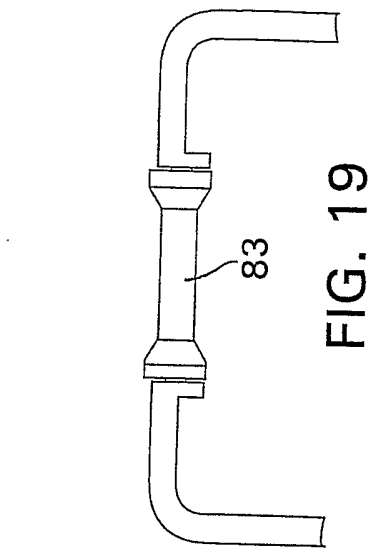

FIG. 19

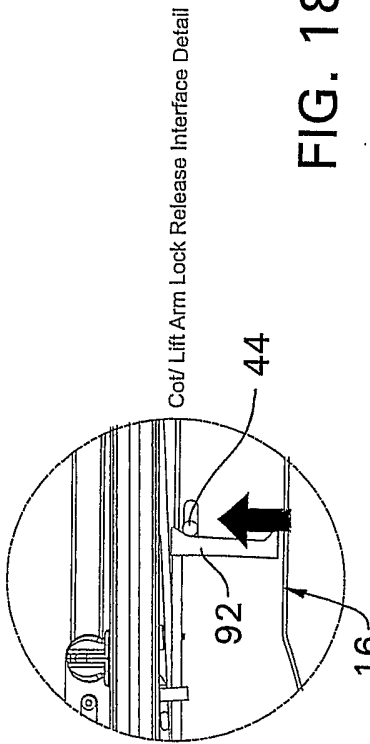

FIG. 18

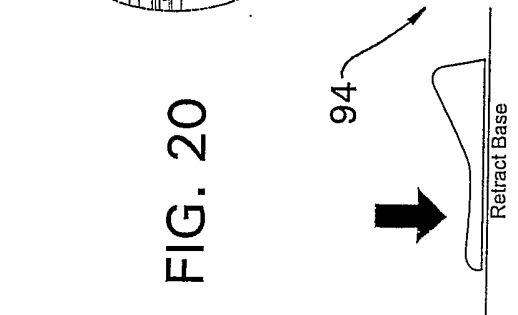

FIG. 20

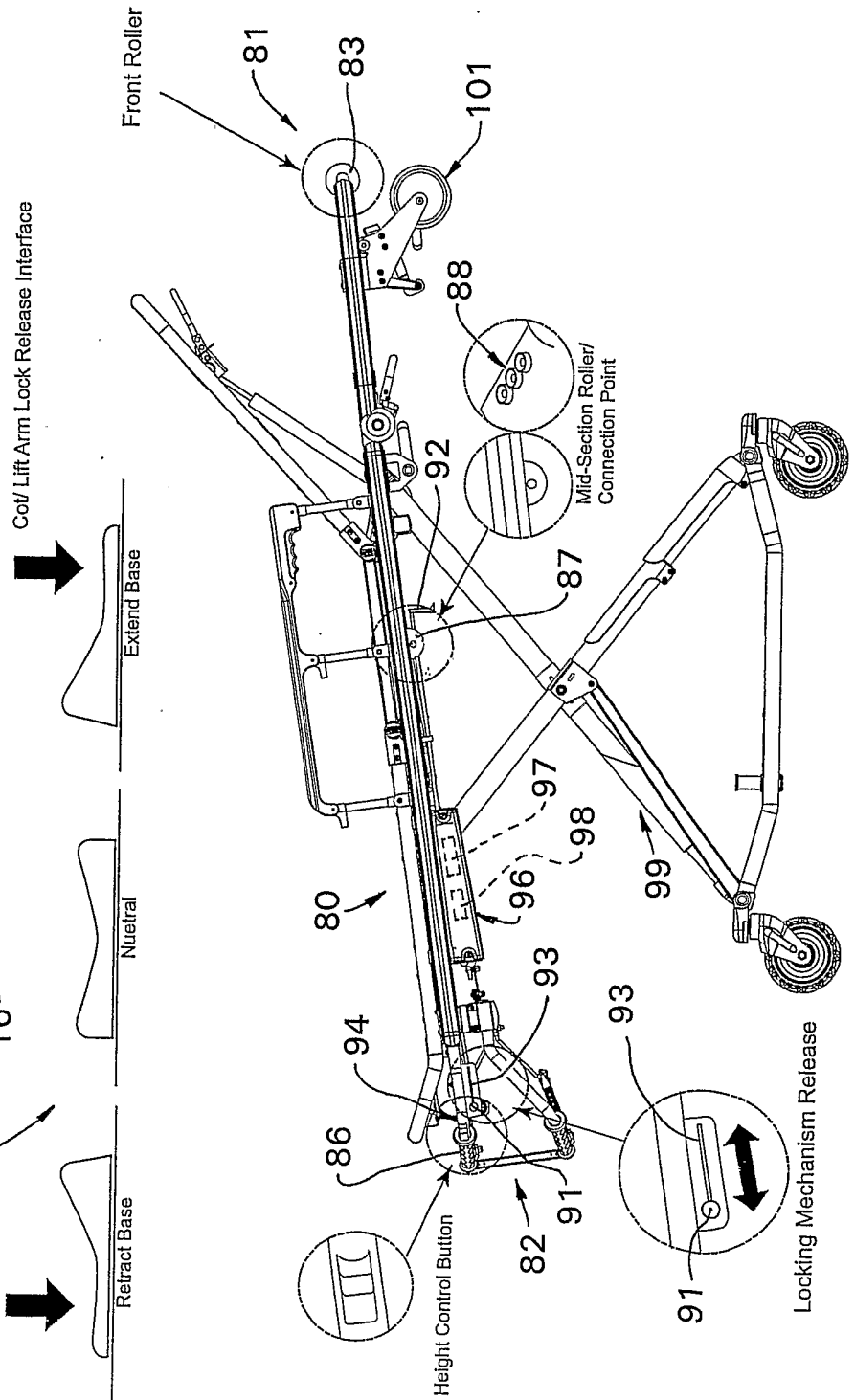

FIG. 18

11/24

Loading Sequence

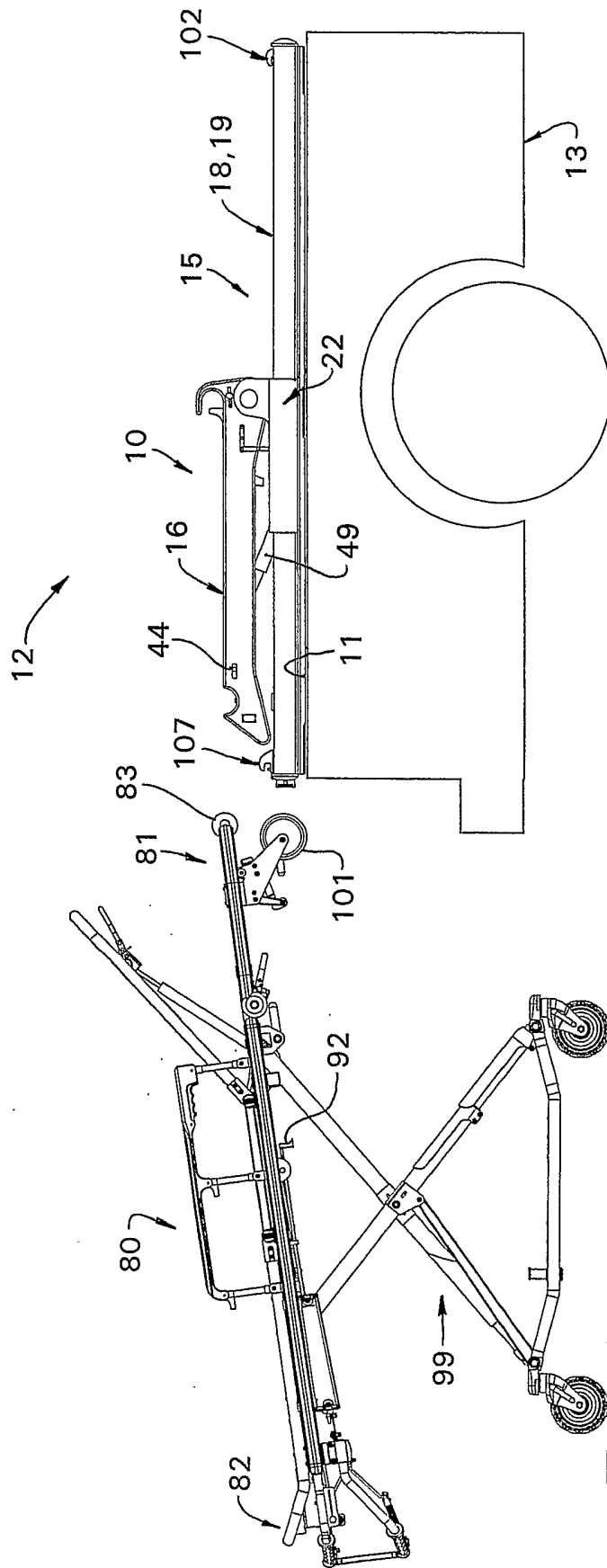

FIG. 21

12/24

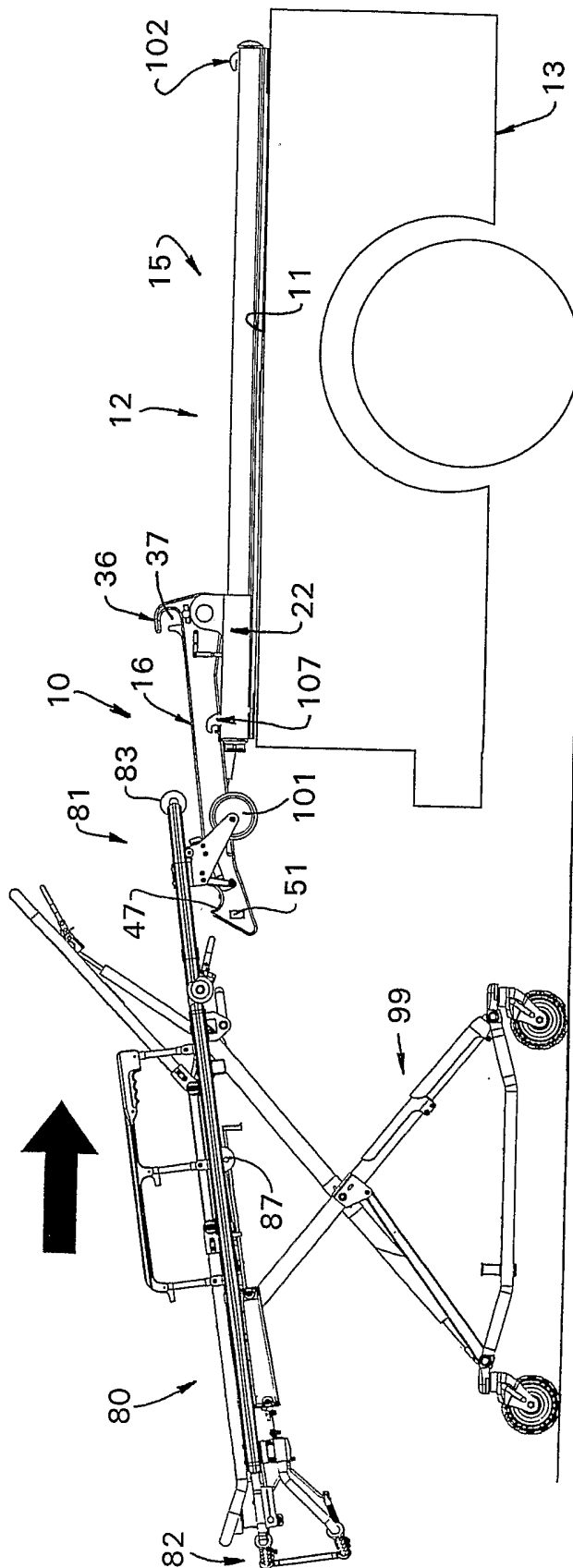

FIG. 22

13/24

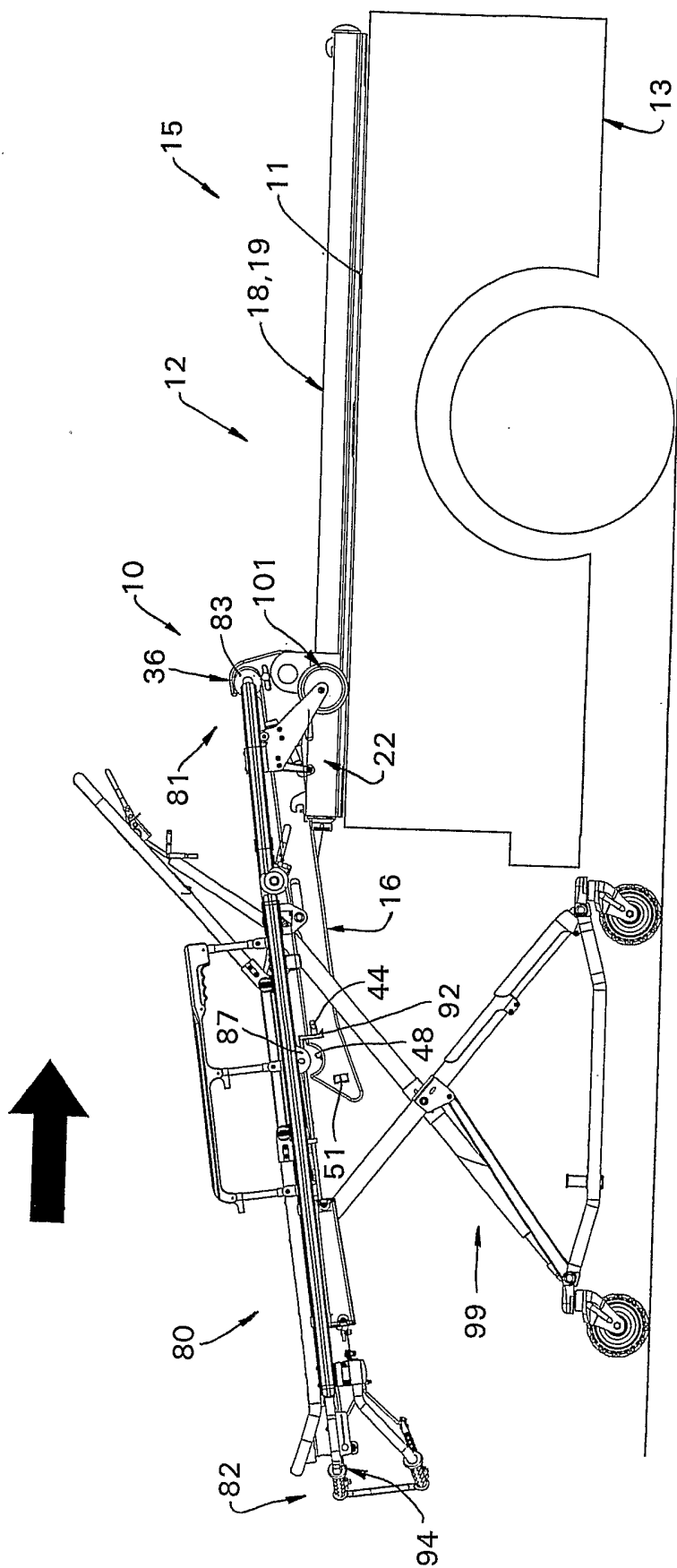

FIG. 23

14/24

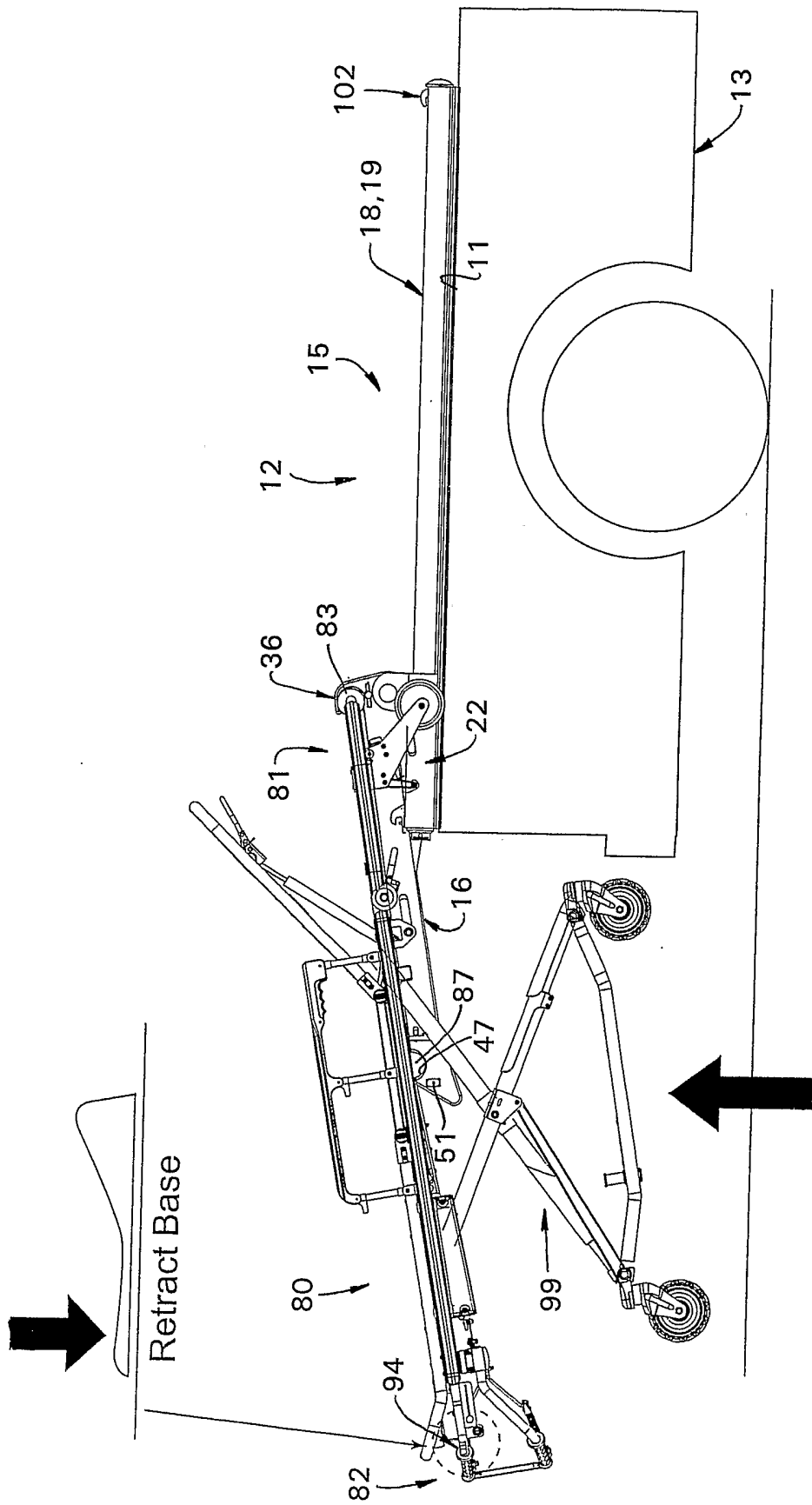
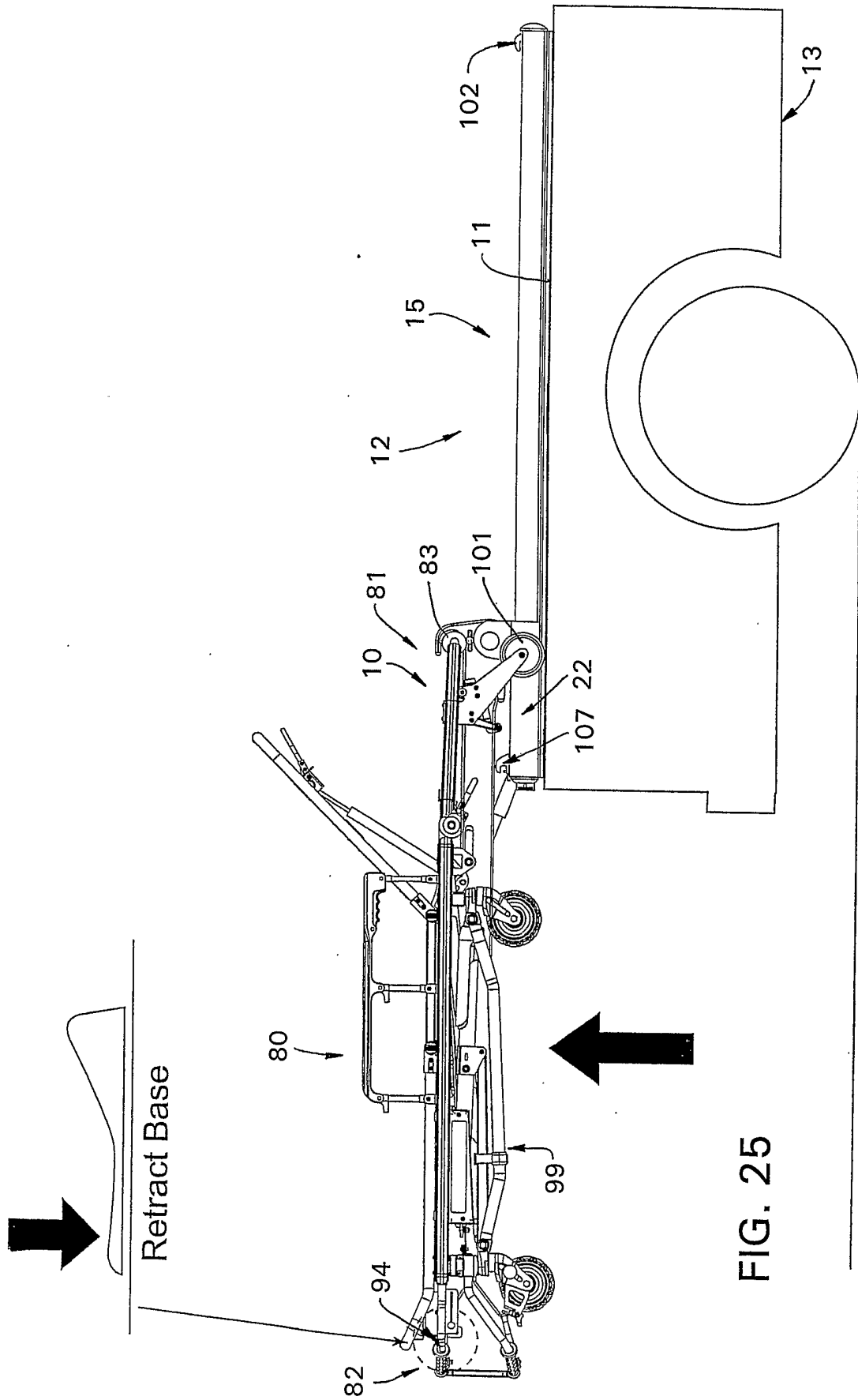

FIG. 24

15/24



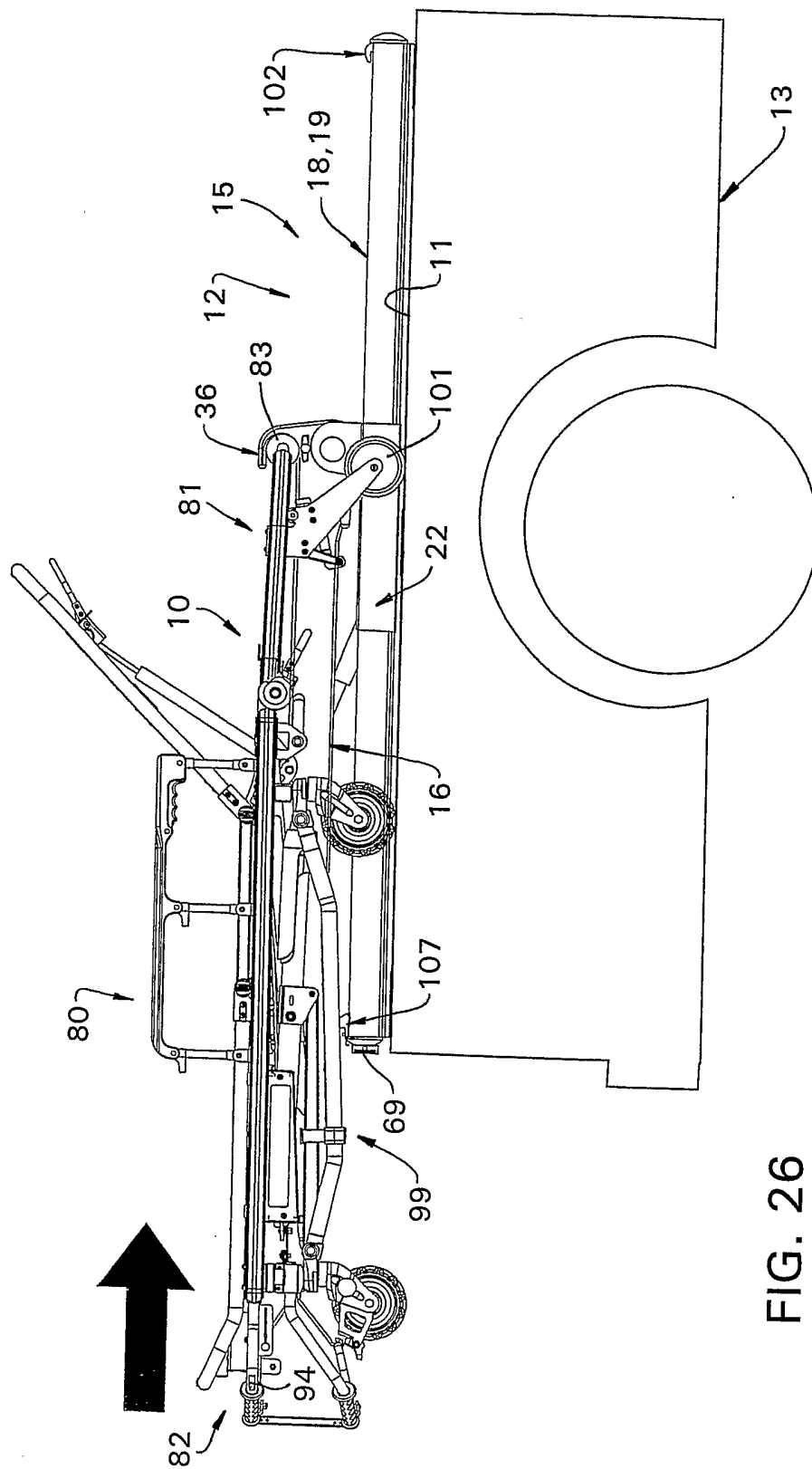

FIG. 26

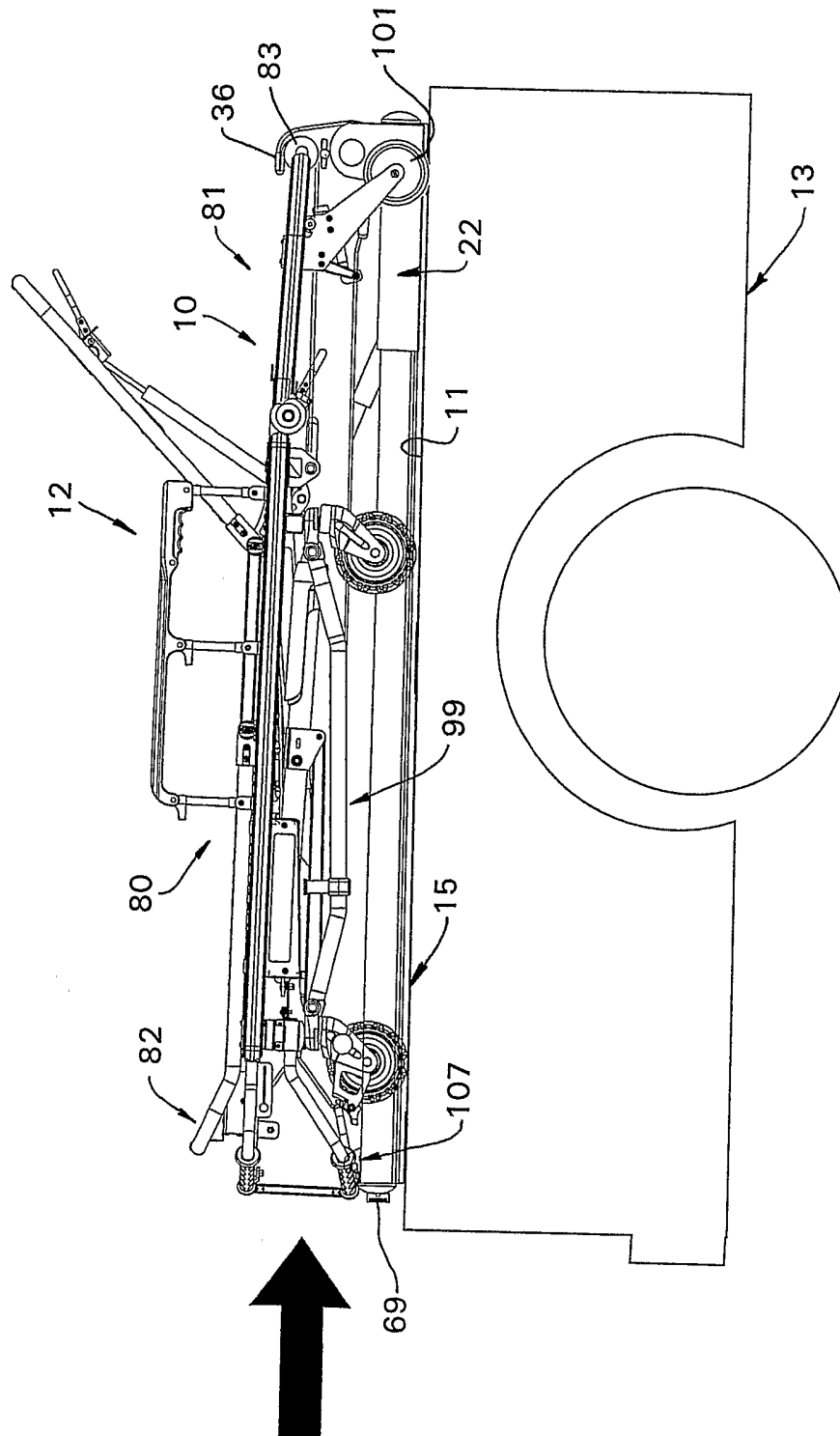

FIG. 27

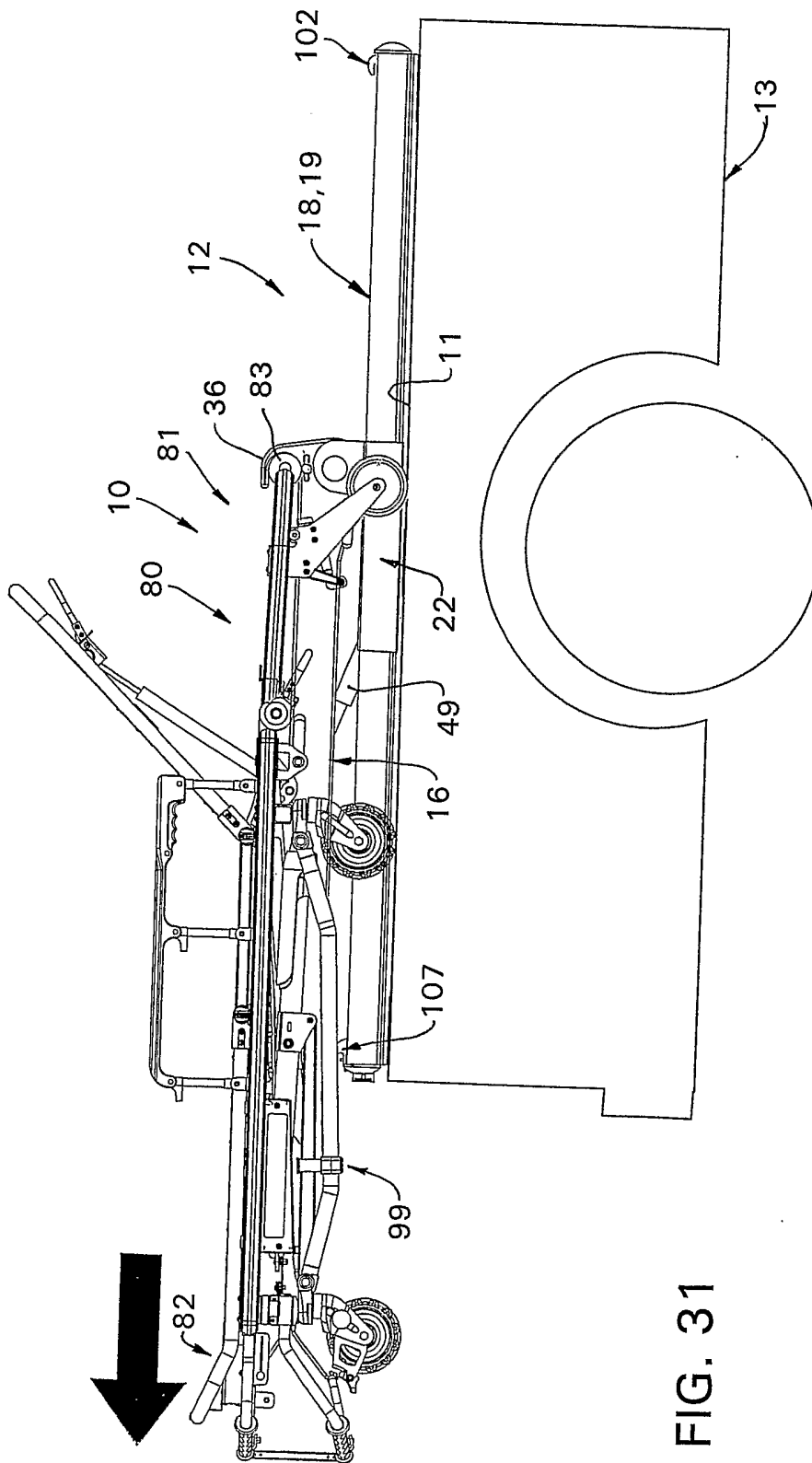

FIG. 31

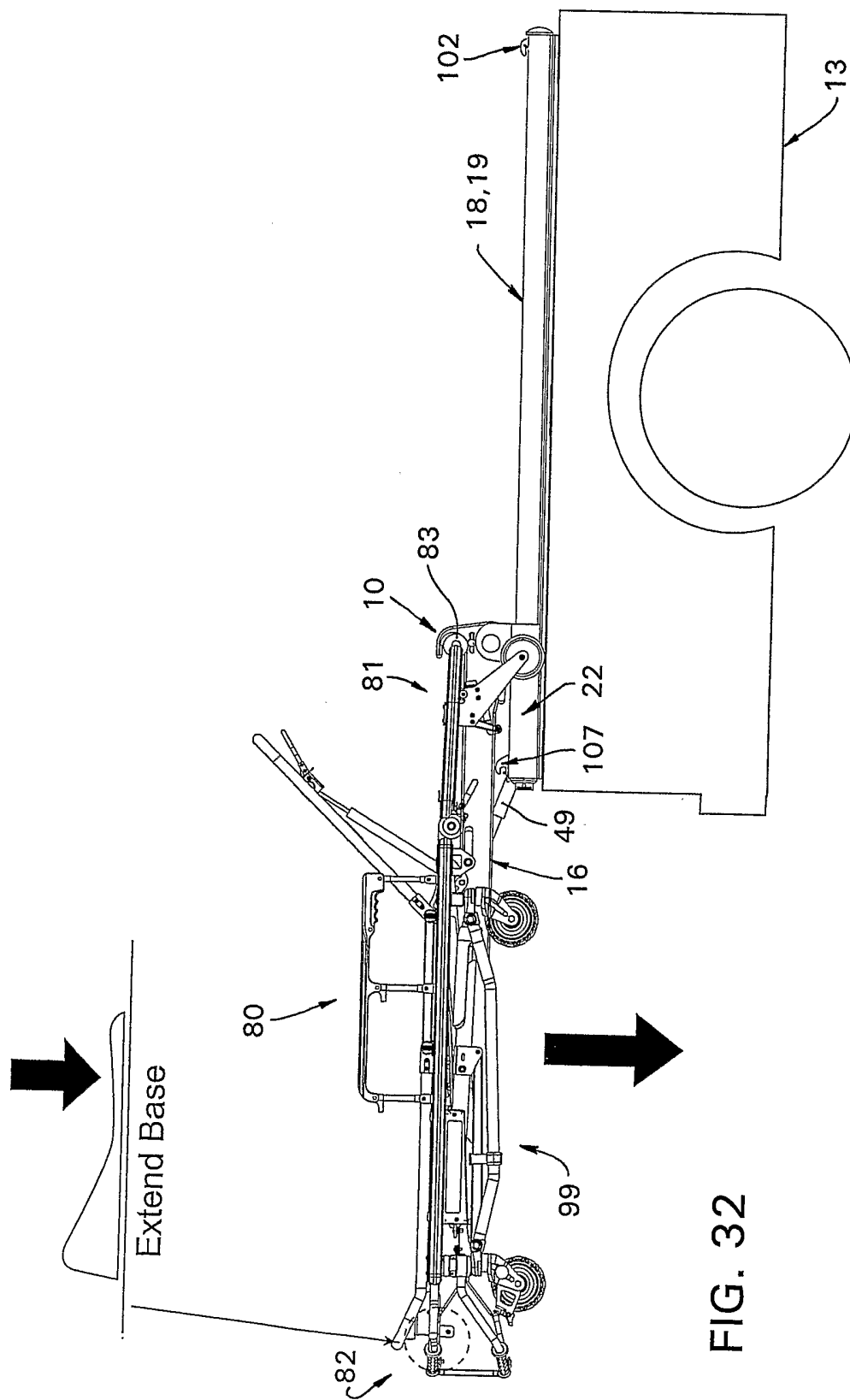

FIG. 32

22/24

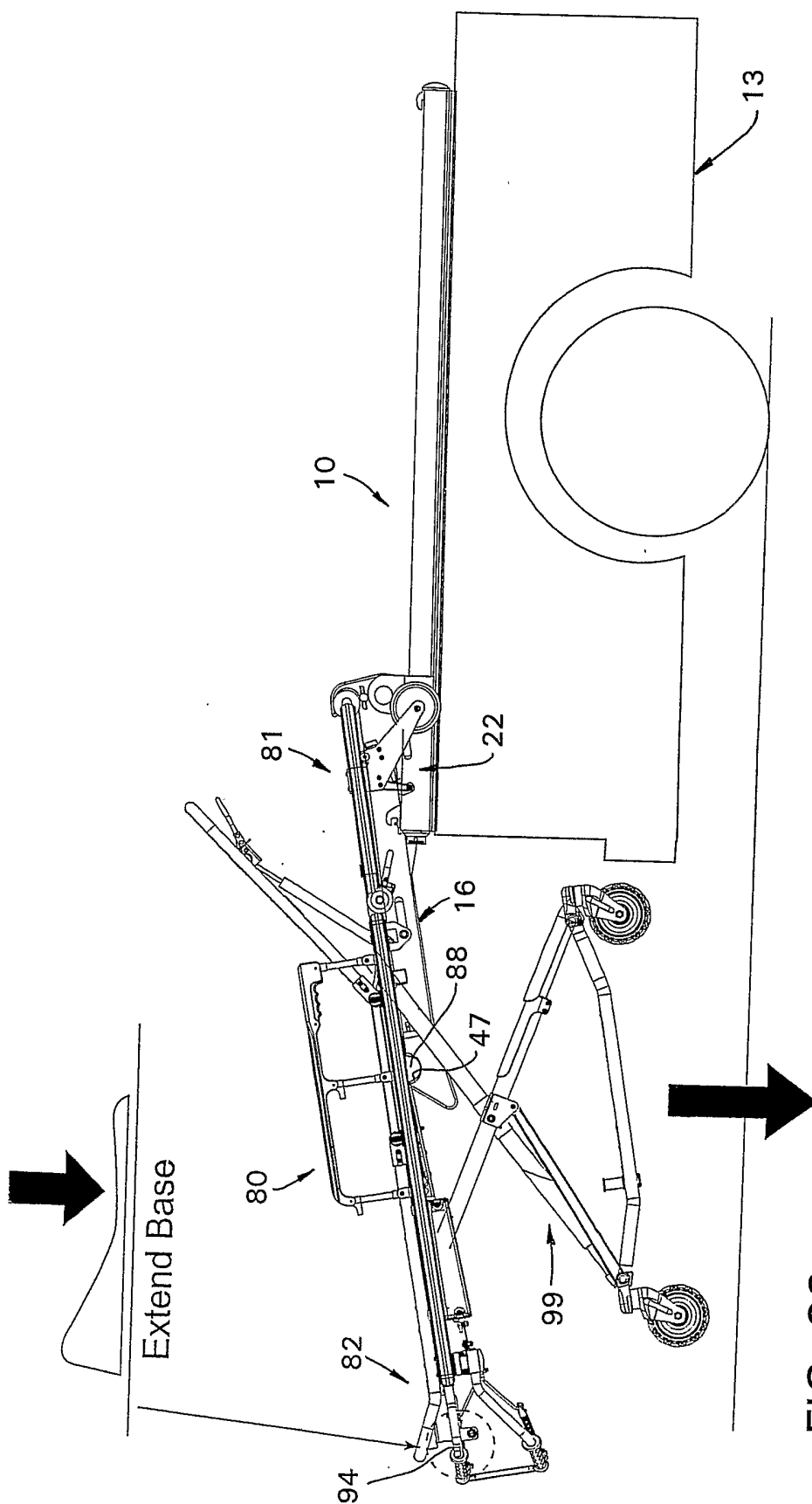

FIG. 33

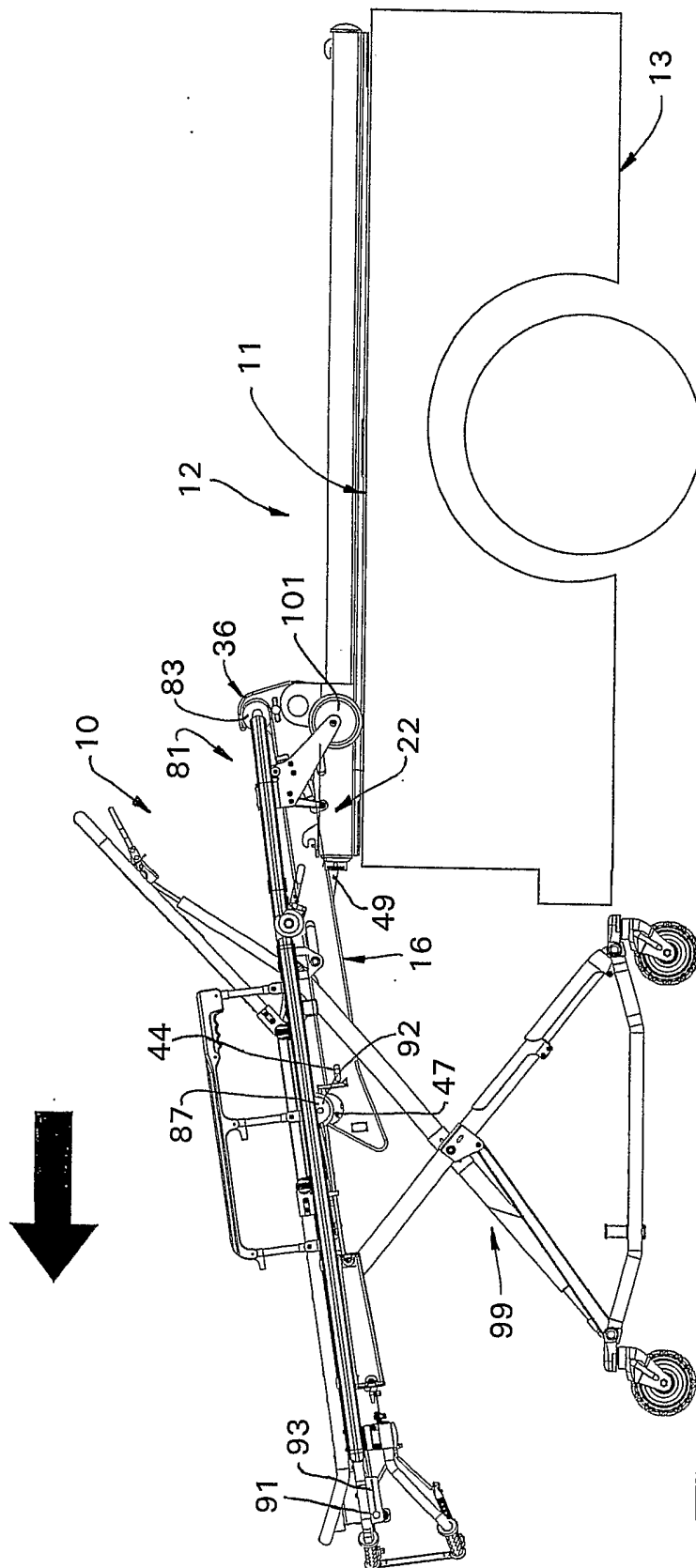

FIG. 34

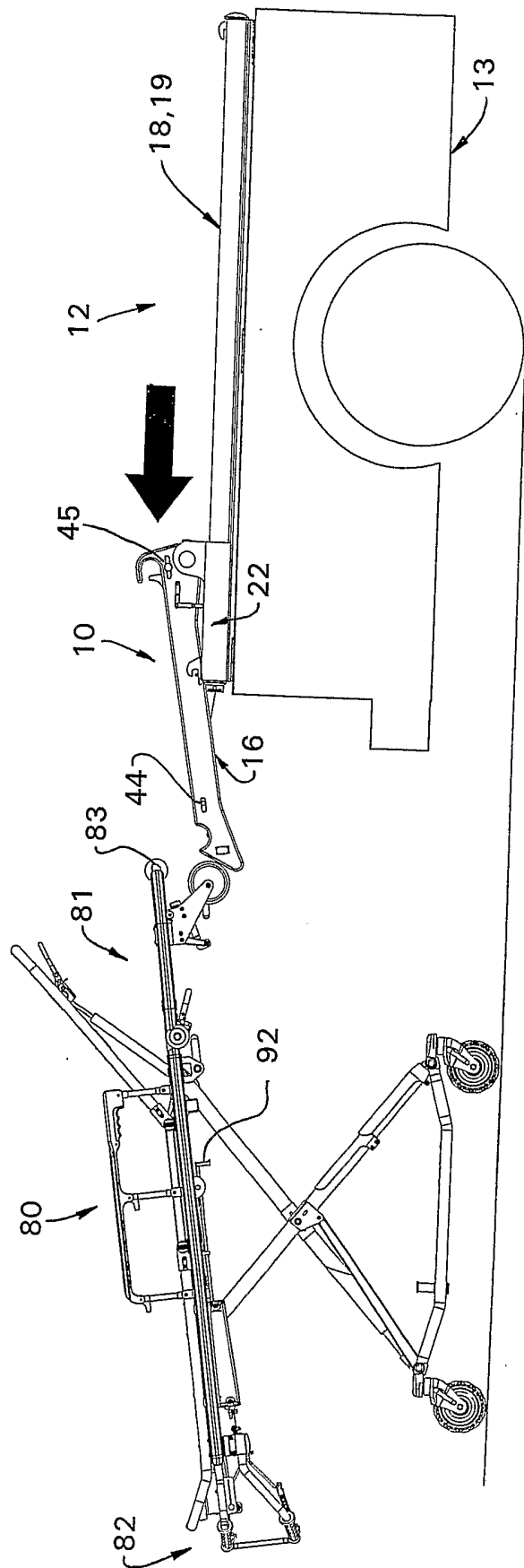

FIG. 35