

CORRECTED VERSION

(19) World Intellectual Property Organization
International Bureau



(43) International Publication Date
4 January 2007 (04.01.2007)

PCT

(10) International Publication Number
WO 2007/002693 A2

(51) International Patent Classification:
G06N 3/02 (2006.01)

(21) International Application Number:
PCT/US2006/025029

(22) International Filing Date: 26 June 2006 (26.06.2006)

(25) Filing Language: English

(26) Publication Language: English

(30) Priority Data:
11/165,892 24 June 2005 (24.06.2005) US
11/270,284 9 November 2005 (09.11.2005) US

(71) Applicant (for all designated States except US): HAL-
LIBURTON ENERGY SERVICES, INC. [US/US];
10200 Bellaire Boulevard, Houston, Texas 77072 (US).

(72) Inventors; and

(75) Inventors/Applicants (for US only): SMITH, Harry, D.,
Jr. [US/US]; 18746 Grand Harbor Point, Montgomery,
Texas 77356 (US). QUIREIN, John, A. [US/US]; 109

Skyline Road, Houston, Texas 78628 (US). GRABLE, Jef-
fery, L. [US/US]; 6218 Laguna Del Ray Drive, Houston,
Texas 77041 (US). CHEN, Dingding [CN/US]; 1705 Coit
Road, #2017, Piano, Texas 75075 (US).

(74) Agents: KRUEGER, Daniel, J. et al.; CONLEY ROSE,
PC, P.O. Box 3267, Houston, Texas 77253-3267 (US).

(81) Designated States (unless otherwise indicated, for every
kind of national protection available): AE, AG, AL, AM,
AT, AU, AZ, BA, BB, BG, BR, BW, BY, BZ, CA, CH, CN,
CO, CR, CU, CZ, DE, DK, DM, DZ, EC, EE, EG, ES, FI,
GB, GD, GE, GH, GM, HN, HR, HU, ID, IL, IN, IS, JP,
KE, KG, KM, KN, KP, KR, KZ, LA, LC, LK, LR, LS, LT,
LU, LV, LY, MA, MD, MG, MK, MN, MW, MX, MZ, NA,
NG, NI, NO, NZ, OM, PG, PH, PL, PT, RO, RS, RU, SC,
SD, SE, SG, SK, SL, SM, SY, TJ, TM, TN, TR, TT, TZ,
UA, UG, US, UZ, VC, VN, ZA, ZM, ZW

(84) Designated States (unless otherwise indicated, for every
kind of regional protection available): ARIPO (BW, GH,

[Continued on next page]

(54) Title: WELL LOGGING WITH REDUCED USAGE OF RADIOISOTOPIC SOURCES

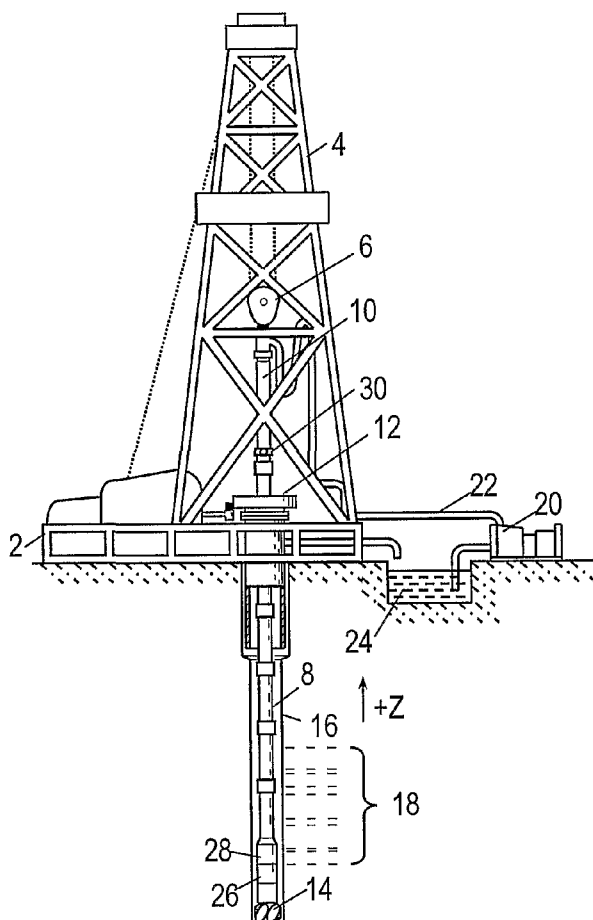

(57) Abstract: Logging systems and methods are disclosed to
reduce usage of radioisotopic sources. Some embodiments com-
prise collecting at least one output log of a training well bore from
measurements with a radioisotopic source; collecting at least one
input log of the training well bore from measurements by a non-
radioisotopic logging tool; training a neural network to predict
the output log from the at least one input log; collecting at least
one input log of a development well bore from measurements
by the non-radioisotopic logging tool; and processing the at least
one input log of the development well bore to synthesize at least
one output log of the development well bore. The output logs
may include formation density and neutron porosity logs.

WO 2007/002693 A2



GM, KE, LS, MW, MZ, NA, SD, SL, SZ, TZ, UG, ZM, ZW), Eurasian (AM, AZ, BY, KG, KZ, MD, RU, TJ, TM), European (AT, BE, BG, CH, CY, CZ, DE, DK, EE, ES, FI, FR, GB, GR, HU, IE, IS, IT, LT, LU, LV, MC, NL, PL, PT, RO, SE, SI, SK, TR), OAPI (BF, BJ, CF, CG, CI, CM, GA, GN, GQ, GW, ML, MR, NE, SN, TD, TG).

Published:

— without international search report and to be republished upon receipt of that report

(48) Date of publication of this corrected version:

22 March 2007

(15) Information about Correction:

see PCT Gazette No. 12/2007 of 22 March 2007

For two-letter codes and other abbreviations, refer to the "Guidance Notes on Codes and Abbreviations" appearing at the beginning of each regular issue of the PCT Gazette.