

(No Model.)

W. B. CLARK.  
THILL COUPLING.

No. 525,334.

Patented Sept. 4, 1894.

Fig. 1.

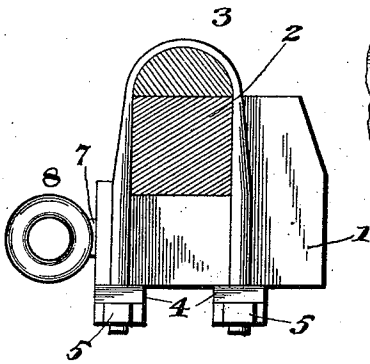

Fig. 2.

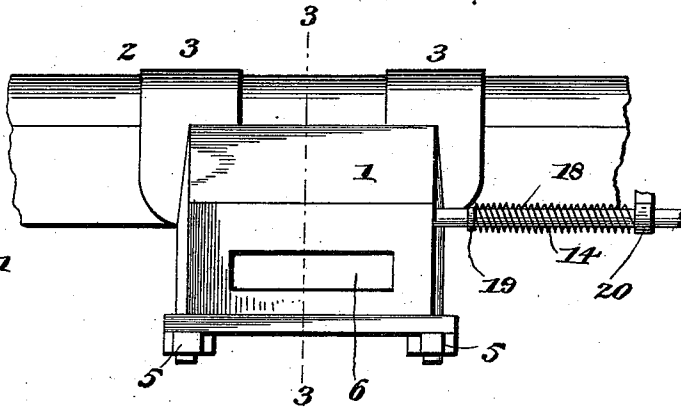

Fig. 4.

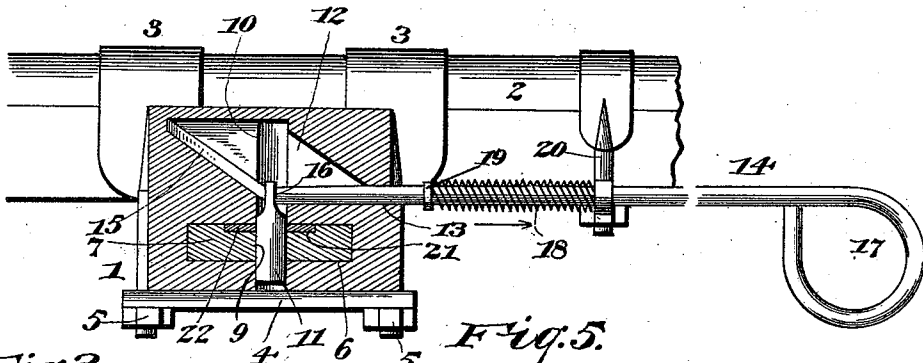

Fig. 3.

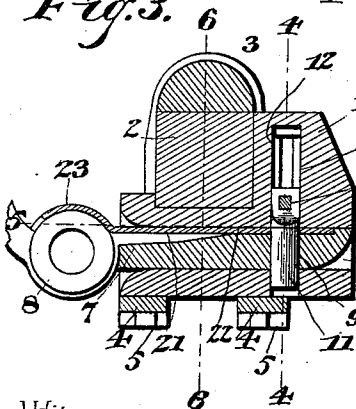

Fig. 5.

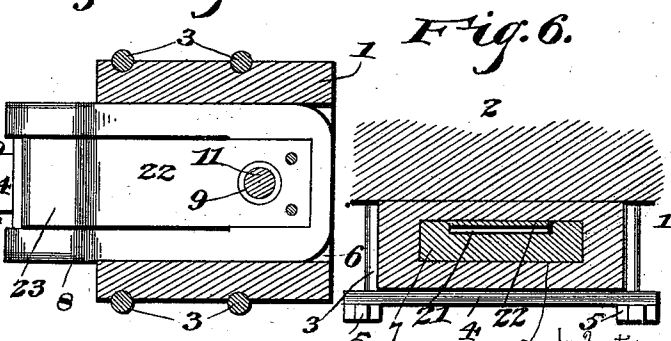

Fig. 6.

Inventor  
Walter B. Clark,

Witnesses

B. S. Ober.  
O. E. Wolfe.

By his Attorneys,

Chas. H. Snow & Co.

# UNITED STATES PATENT OFFICE.

WALTER B. CLARK, OF CHICAGO, ILLINOIS, ASSIGNOR OF ONE-HALF TO  
CHARLES LUDLAM, OF SAME PLACE.

## THILL-COUPLING.

SPECIFICATION forming part of Letters Patent No. 525,334, dated September 4, 1894.

Application filed November 28, 1893. Serial No. 492,234. (No model.)

*To all whom it may concern:*

Be it known that I, WALTER B. CLARK, a citizen of the United States, residing at Chicago, in the county of Cook and State of Illinois, have invented a new and useful Anti-Rattling Thill-Coupler and Horse-Detacher, of which the following is a specification.

My invention relates to improvements in thill couplings, and has for its object to provide anti-rattling and horse-detaching means, whereby lost motion caused by wear is taken up, and whereby the thills may be disconnected from the vehicle with facility and celerity.

Further objects and advantages of this invention will appear in the following description, and the novel features thereof will be particularly pointed out in the appended claims.

In the drawings: Figure 1 is a side view of a thill-coupling embodying my invention. Fig. 2 is a rear view of the same, with the eye-bearing tongue removed. Fig. 3 is a vertical section on the line 3—3 of Fig. 2. Fig. 4 is a section on the line 4—4 of Fig. 3. Fig. 5 is a horizontal section on the line 5—5 of Fig. 3. Fig. 6 is a vertical section on the line 6—6 of Fig. 3.

Similar numerals of reference indicate corresponding parts in all the figures of the drawings.

1 designates a box, which is secured to the axle 2 by means of the clips 3, of the ordinary construction, said clips having the plates 4 and securing-nuts 5. This box is provided with a horizontal recess 6, in which is removably fitted the tongue 7, upon the front end of which is formed an eye 8, for the attachment of a thill. The means for the attachment of a thill to the said eye may be of the ordinary or any preferred construction and form no part of my invention. The tongue is provided, near its rear end, with a vertical socket 9, and formed in the box in alignment with this socket is a vertical guide 10, in which is slidably fitted a coupling pin 11.

Formed in the box, above the plane of the horizontal recess 6, is a cavity 12, having a reduced mouth 13, in which is slidably fitted an uncoupling rod 14. This uncoupling rod

is provided with an angularly-disposed extension or arm 15, which operates within the cavity 12, and by its deflection prevents the detachment of the uncoupling rod from the box. This deflected extension or arm of the uncoupling rod engages a transverse perforation 16 in the upper end of the coupling pin, whereby, as the uncoupling rod is moved horizontally in the direction indicated by the arrow in Fig. 4, the effect of the inclined extension or arm 15 will be to elevate the coupling pin, and thereby disengage it from the socket in the eye-bearing tongue 7.

The uncoupling rod is preferably arranged in rear of the axle and parallel therewith, and it preferably terminates near the center of the axle or beneath the fifth-wheel in a fingerhold 17, whereby the uncoupling rod of the two thill-couplings, with which a vehicle is provided, is so arranged as to enable an operator to disconnect both thills at the same time.

To maintain the uncoupling rod normally in position to hold the coupling pin in its operative or engaged position, I employ an actuating spring 18, which bears at one end against a slight projection or collar 19 on the rod, and at the other end against a hanger or clip 20, which forms an additional guide for the rod.

From the above description it will be understood that the uncoupling rod, in addition to forming a means of disengaging the coupling pin, serves to hold the latter in its operative position, and prevent accidental detachment of the eye-bearing tongue when the rod is in its normal position.

The upper side of the eye-bearing tongue, as shown clearly in Figs. 3, 4, and 6, is channeled, as at 21, and an anti-rattling plate-spring 22 is disposed in this channel, and bears at its front end upon the upper side of the recess in the box and at its rear end upon the tongue. This spring is further provided, at its front end, with an extension 23, having a concave under side to engage the upper surface of a thill-eye, as indicated in Figs. 3 and 5.

Various changes in the form, proportion, and the minor details of construction may be

resorted to without departing from the principle or sacrificing any of the advantages of this invention.

Having described my invention, what I claim is—

1. In a thill-coupling, the combination with a box provided with a horizontal recess, and an eye-bearing tongue removably fitted in said recess, of a vertically-movable coupling pin adapted to engage a socket in said eye-bearing tongue, and an uncoupling rod provided with a deflected extension or arm engaging a perforation in said coupling pin and adapted, when the uncoupling rod is moved, to cause a vertical reciprocation of the coupling pin, substantially as specified.

2. The combination with a box provided with a horizontal recess, and an eye-bearing tongue fitted removably in said recess and provided with a socket, of a coupling pin slidably fitted in a vertical guide in the box, an uncoupling rod fitting slidably in a horizontal cavity in communication with said guide and provided with a deflected extension or arm engaging a transverse perforation in the coupling pin, and an actuating spring connected to the uncoupling rod to hold the latter normally in a position to maintain the coupling pin depressed and in engagement with the socket of the eye-bearing tongue, substantially as specified.

3. The combination with a box provided with a horizontal recess, an eye-bearing tongue removably fitted in said recess and provided with a vertical socket, and a vertically-guided coupling pin arranged to engage said socket when depressed, of an uncoupling rod arranged in a cavity above the plane of said recess and provided with a deflected extension or arm engaging a transverse perforation in the coupling pin and terminating at its inner end in a fingerhold, a fixed guide for the inner end of the uncoupling rod, and an actuating spring coiled upon the said rod

and connected at opposite ends, respectively, to the rod and to the said guide, substantially as specified.

4. The combination with a box provided with a horizontal recess, of an eye-bearing tongue removably fitted in said recess and provided in its upper side with a longitudinal channel, means for detachably locking the tongue in said recess, and a plate spring arranged in the channel of the tongue, bearing at its front end against the roof of the recess, and provided with a forward downwardly-concaved extension to bear upon the upper surface of a thill-eye, substantially as specified.

5. In a thill coupling, the combination with a box provided with a horizontal recess, and an eye-bearing tongue removably fitted in said recess, of a vertically-movable coupling pin adapted to engage a socket in said eye-bearing tongue, and an uncoupling rod engaging said coupling pin and adapted, when the uncoupling rod is moved, to cause a vertical reciprocation of the coupling pin, substantially as specified.

6. The combination with a box provided with a horizontal recess, of an eye-bearing tongue removably fitted in said recess, means for detachably locking the tongue in said recess, and a plate spring arranged on top of the tongue and provided with a forward downwardly-concaved extension to bear upon the upper surface of a thill-eye, said spring being secured in place by the same means that lock the tongue in place, substantially as specified.

In testimony that I claim the foregoing as my own I have hereto affixed my signature in the presence of two witnesses.

WALTER B. CLARK.

Witnesses:

FRANK HUCKELL,  
JAMES J. CASEY.