

No. 762,979.

PATENTED JUNE 21, 1904.

A. H. & O. G. BERNs.
FOLDING CARRIER FRAME.
APPLICATION FILED FEB. 8, 1904.

NO MODEL.

2 SHEETS—SHEET 1.

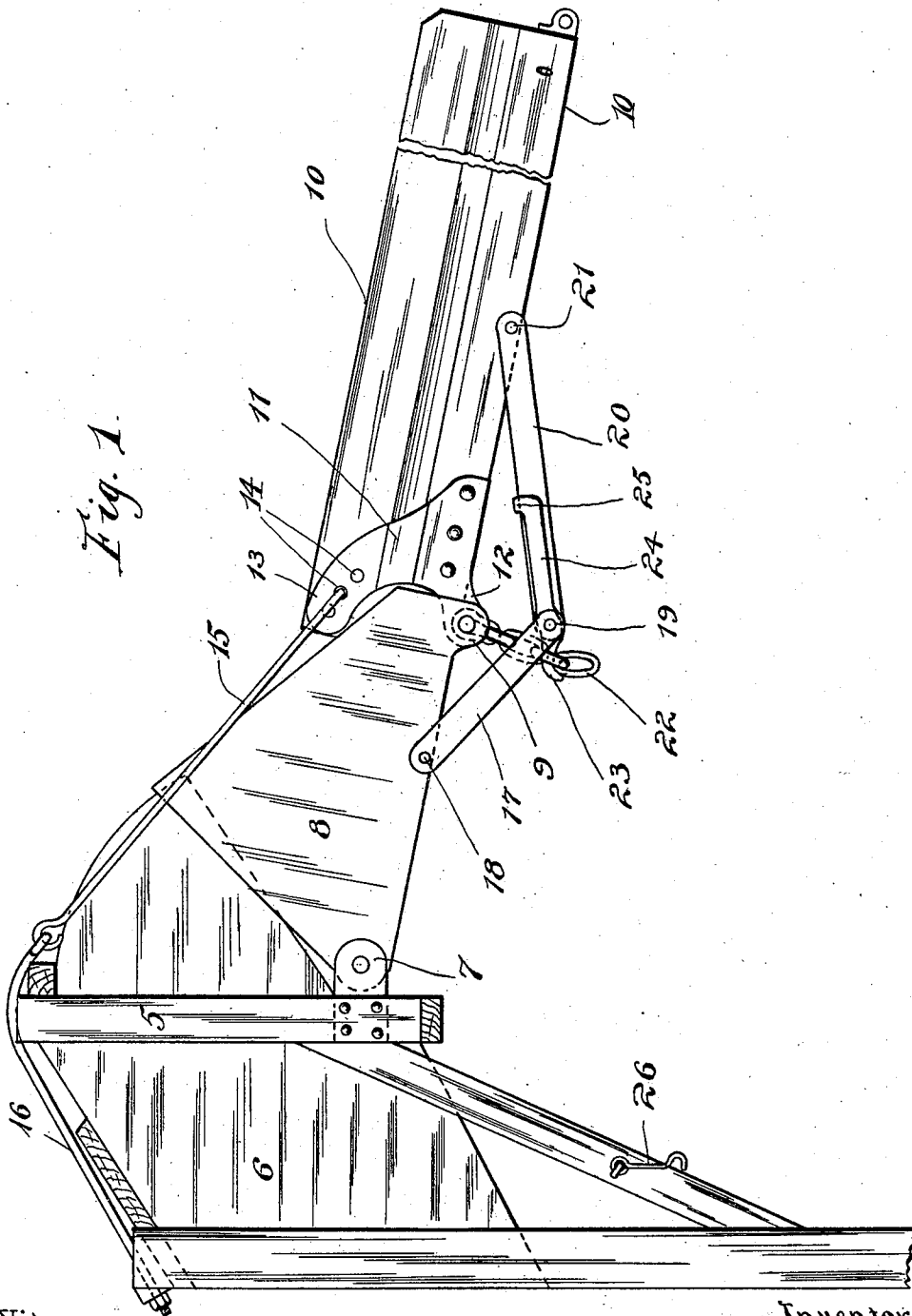

Fig. 1.

Witnesses:

Durk Bean.

M. C. Lichtberg.

Inventors:

Andrew Herman Berns,

and Otto George Berns,

By

Glenn S. Noble

Att'y.

A. H. & O. G. BERNS.
FOLDING CARRIER FRAME.

APPLICATION FILED FEB. 8, 1904.

NO MODEL.

2 SHEETS—SHEET 2.

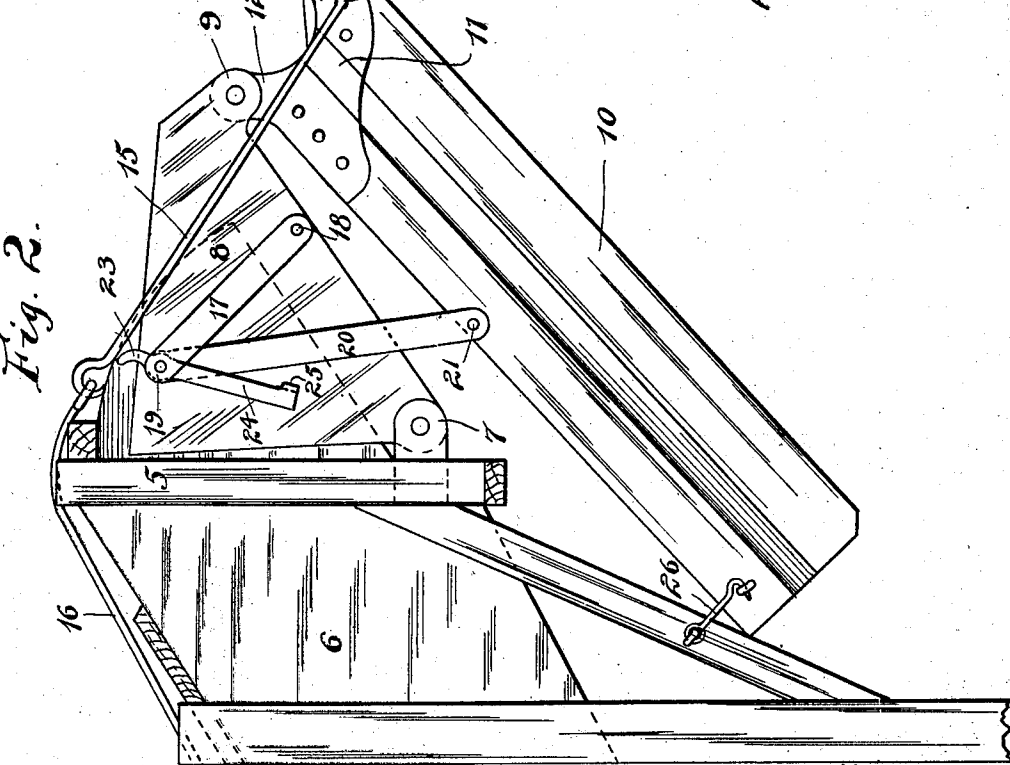
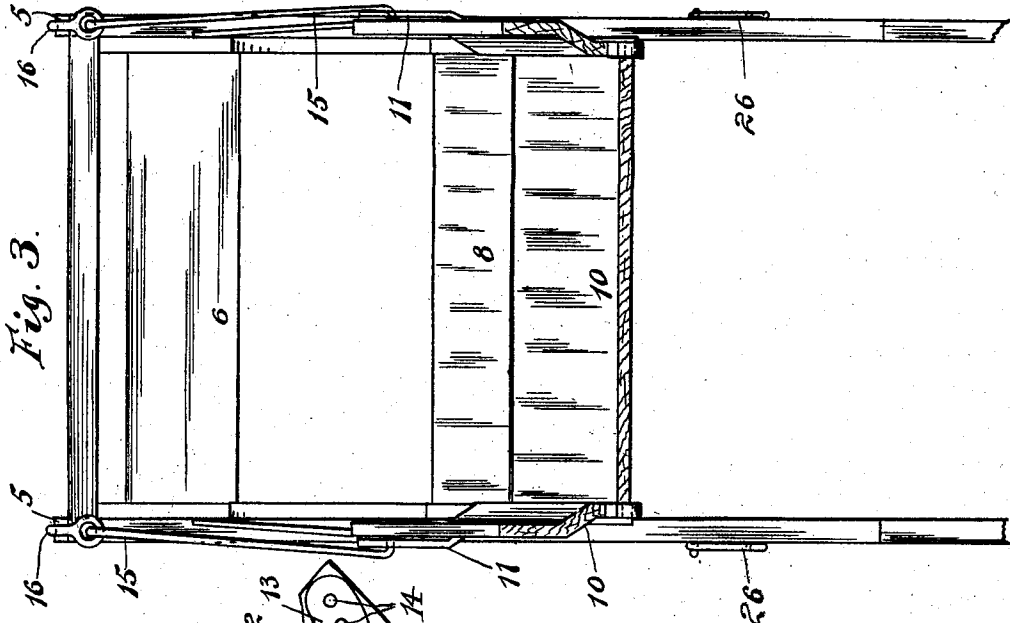

Fig. 3.

Fig. 2.

Witnesses:
Burt Bean
M. C. Lichtberg

Inventors,
 Andrew Herman Berns,
 and Otto George Berns,
 By *Glenn S. Noble*
 Atty.

UNITED STATES PATENT OFFICE.

ANDREW HERMAN BERNES AND OTTO GEORGE BERNES, OF CHEBANSE,
ILLINOIS.

FOLDING CARRIER-FRAME.

SPECIFICATION forming part of Letters Patent No. 762,979, dated June 21, 1904.

Application filed February 8, 1904. Serial No. 192,510. (No model.)

To all whom it may concern:

Be it known that we, ANDREW HERMAN BERNES and OTTO GEORGE BERNES, citizens of the United States, residing at Chebanse, in the county of Kankakee and State of Illinois, have invented certain new and useful Improvements in Folding Carrier-Frames, of which the following is a specification.

This invention relates more particularly to a folding frame, guideway, or the like which is adapted to be used for any desired purpose, but is more particularly designed for use in connection with threshing-machines.

This invention provides means whereby the folding carrier-frame may be entirely supported from the machine, thereby doing away with stakes, legs, or the like at the outer end of the frame. It also provides means whereby upon releasing the frame from its folded position it will automatically swing out and up to operative position and will lock itself in the latter position. Means are also provided for rigidly securing the frame in locked position.

The objects of this invention are to provide means for constructing a folding frame whereby the latter will operate as above set forth and means whereby a convenient and rigid construction is secured.

This invention is illustrated in the accompanying drawings, in which—

Figure 1 is a side elevation of the folding carrier-frame shown in operative position as attached to the end of a threshing-machine frame. Fig. 2 is a similar view showing the frame in folded position. Fig. 3 is a front end view of the frame shown in Fig. 1.

The outer posts 5 of a threshing-machine frame 6 are provided with bearings 7, which pivotally support the first section 8 of the folding carrier-frame. At the outer end of the section 8 are bearings 9, which pivotally support the outer or second section 10 of the carrier-frame.

One of the important details of this invention are the bearing-brackets 11, which support the outer section 10. These brackets or castings 11 are provided with projections 12, adapted to form one part of the hinged sup-

port at 9, and with an upwardly-extending arm 13, provided with a plurality of holes 14; rods or the like 15, adapted to engage at one end with corresponding holes 14 in the brackets 11 and at the opposite end with eyes of rods 16, which are bent over the end posts 5 and engage with the frame-posts of the machine, where they are provided with nuts to allow for a limited adjustment. The arrangement is such that when the two sections of the carrier-frame are swung up to the position shown in Fig. 1 they lock with each other to prevent a further rotation on their hinged connection. At either side of the section 8 are arms 17, which are pivoted at 18 to the section and at 19 to the outer ends of arms 20, the latter being pivoted at 21 to the section 10. These arms are so proportioned that their connected ends are at a desired distance below the bearings 9 when the frame is in operative position. By connecting the shaft which forms the hinge-pivot with the ends of said arms the latter will brace the folding frame. For this purpose a chain or equivalent device 22 is hung from the shaft and is adapted to be engaged by a hook 23 on the arm of a lever 24, also pivoted at 19. The opposite end of this arm is provided with a catch or hook 25 to engage the upper edge of the arm 20. This arm is slightly flexible or loosely mounted on its pivot in order to allow the catch or hook 25 to be brought into engagement with and released from the edge of the arm 20. By means of this device the lever 24 is first released from the arm 20, as shown in Fig. 2. Then when the frame is swung up into position the hook is brought into engagement with the chain, and by raising the end of the lever the arms 17 and 20 will be forced upward to support the frame-sections and will be held by bringing the catch 25 into engagement with the upper edge of the arm 20.

When it is desired to fold the frame, the lever 24 is released and the hook disengaged from the chain. Then by swinging down the outer end of section 10 the folding frame may be brought to the position shown in Fig. 2, where it will be locked by the side hooks 26. When it is again desired to place the frame

in operative position, the hooks 26 are simply released and the weight of the outer section will swing the same out until by means of the novel method of hinging and supporting said frames the weight of the inner section will bear down on the connecting hinge and the entire frame will automatically swing to the position shown in Fig. 1. When the outer section 10 is released from the hooks 26, it will swing up to the position shown in Fig. 1. When this section is released, the momentum of the swinging end is sufficient to carry it out until the pivot or hinge 9 is below the rod 15 and its point of attachment 14. The weight of the inner section will then bear down upon the pivot and will complete the raising or swinging of the outer section until it reaches the position of alinement or locking position. (Shown in Fig. 1.) However, it will be noted that when the carrier is again folded it does not automatically assume the position shown in Fig. 2; but the outer end must be pushed in in order to be locked.

It will be noted that the parts shown on the side in Fig. 1 are preferably duplicated on the opposite side, and the side pieces of the section 8 are adapted to slide along on the projecting side pieces of the machine proper. This folding frame may be provided with the usual conveyer apparatus; but as it forms no part of this invention the latter has not been shown.

While we have described our invention in connection with a threshing-machine, it is evident that the same may be used for various other purposes, and we do not wish to limit ourselves to the use set forth. Neither do we wish to limit ourselves to the exact details of construction, as it is apparent that various changes in the details will readily suggest themselves as coming within the scope of our invention; but

What we claim, and desire to secure by Letters Patent, is—

1. The combination with a suitable support, of a folding frame comprising a first section pivoted to said support, and a second section pivoted to said first section, and means connecting between said support and said second section, whereby the weight of said first-named section will carry the outer section to operative position after said outer section has been released from folded position, and will hold the frame in operative position.

2. The combination with a suitable machine-frame, of a folding carrier-frame, pivotal connections between the sections of said carrier-frame and between said frame and the machine-frame, a supporting-plate on the outer

section of said carrier-frame having a plurality of holes therein, a swinging rod, a bearing for said rod at the upper part of the machine-frame, and means at the lower end of said rod for engagement with the holes of said supporting-plate.

3. In combination with a support, a folding frame-section pivotally connected with said support, a second frame-section pivotally connected with said first-named section, bearing-plates for said second-named section having projections adapted to form apart of the pivotal connection and having upwardly-extending arms, adjustable bearing-rods in the first-named support at some distance above the pivotal connections with the frame-section, swinging rods or the like adapted to engage with said adjustable rods, and means for adjustably engaging said swinging rods with said upwardly-extending arms of the bearing-plates.

4. The combination with a folding carrier-frame, of arms pivotally connected to the sections of said frame and pivotal connections at their outwardly-extending ends, and means for rigidly connecting the outwardly-extending ends of said arms with the hinge of said carrier-frame whereby the arms will lock said frame in position.

5. The combination with the hinged sections of a folding carrier-frame, of arms secured to said sections, means for connecting the downwardly-extending ends of said arms, a chain or the like depending from the hinge between said sections, and a lever provided with a hook adapted to engage with a link of said chain and a catch at the opposite end of said lever adapted to engage one of said arms when the chain has been drawn tight.

6. The combination with a threshing-machine, of a folding carrier-frame, comprising a first section pivoted to the frame of said machine, a second section pivoted to said first section, means connecting between said machine-frame and said second section, whereby the two sections may be folded with the end of the outer section against the machine-frame, the arrangement being such that said sections will swing to operative position by the force of gravity when released from folded position, and means for locking said sections in operative position, substantially as described.

ANDREW HERMAN BERNIS.
OTTO GEORGE BERNIS.

Witnesses:

H. C. BERNIS,
A. J. BUTLER.