

(19) World Intellectual Property Organization  
International Bureau



(43) International Publication Date  
25 July 2002 (25.07.2002)

PCT

(10) International Publication Number  
WO 02/056955 A1

- (51) International Patent Classification<sup>7</sup>: A61M 29/00, 25/00, 5/00, A61F 11/00
- (74) Agent: KAPPOS, John, C.; Lyon & Lyon, 633 W. Fifth Street, Suite 4700, Los Angeles, CA 90071-2066 (US).
- (21) International Application Number: PCT/US02/00700
- (81) Designated States (*national*): AU, CA, JP.
- (22) International Filing Date: 11 January 2002 (11.01.2002)
- (84) Designated States (*regional*): European patent (AT, BE, CH, CY, DE, DK, ES, FI, FR, GB, GR, IE, IT, LU, MC, NL, PT, SE, TR).
- (25) Filing Language: English
- (26) Publication Language: English
- (30) Priority Data:  
09/766,690 18 January 2001 (18.01.2001) US
- Published:  
— with international search report  
— before the expiration of the time limit for amending the claims and to be republished in the event of receipt of amendments
- (71) Applicant: EMBOL-X, INC. [US/US]; 645 Clyde Avenue, Mountain View, CA 94043-2213 (US).
- (72) Inventor: LILLY, Richard; 1281 Sabal Drive, San Jose, CA 95132 (US).
- For two-letter codes and other abbreviations, refer to the "Guidance Notes on Codes and Abbreviations" appearing at the beginning of each regular issue of the PCT Gazette.*

(54) Title: ARTERIAL CANNULA WITH PERFORATED FILTER LUMEN

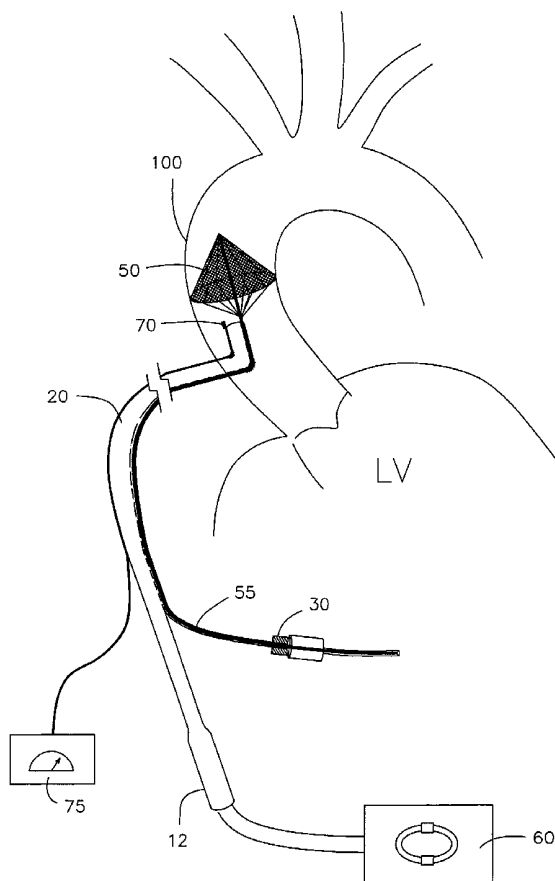

(57) Abstract: An apparatus and methods for protecting a patient from embolization during cardiovascular procedure, wherein the apparatus includes a cannula which comprises an elongate tubular member having a first lumen (20) and a second lumen (25). The lumens (20, 25) are separated by a perforated wall (35), that allows blood flow between the two lumens (20, 25). The first lumen (20) is adapted to receive oxygenated blood from a bypass oxygenator. The second lumen (25) is adapted to receive a filter wire (50). The proximal end of the second lumen (25) may include a hemostatic valve (30). The distal end of the cannula may include a manometer (70) for measuring blood pressure. The cannula may also include mechanism that allows regulation of blood flow in the second lumen.

WO 02/056955 A1

## Arterial Cannula With Perforated Filter Lumen

### Field of the Invention

5 The present invention relates generally to medical devices for protecting a patient from embolization during cardiovascular procedures. More particularly, the devices comprise a filter insertable within a double-lumen cannula that is useful for arterial cannulation.

### Background of the Invention

10 Cardiopulmonary bypass and cardiac arrest are often required in both conventional and minimally invasive coronary artery bypass grafting surgeries, and other cardiovascular surgeries, such as ventricular septal defect repair, heart valve repair or replacement, ventricular myomectomy, aortic aneurysm repair, or aortic thrombectomy. In order to arrest the heart, the heart and coronary arteries must be  
15 isolated from the peripheral vascular system, so that cardioplegia solution can be infused to paralyze the heart without paralyzing the peripheral organs. Cardiopulmonary bypass is initiated to maintain peripheral circulation by withdrawing venous blood, passing the deoxygenated blood through a bypass-oxygenator, and  
infusing oxygenated blood into the aorta.

20 It is well recognized that one of the complications associated with cardiovascular procedures is dislodgment of thromboembolic material from a cardiac chamber and/or the aorta. The embolic materials, *e.g.*, calcium, intimal debris, atheromatous plaque, thrombi, and/or air, generated during manipulation of the cardiovascular tissue, travel downstream and cause occlusion of the narrower vessels  
25 and ischemia or infarct of the organ that the vessel supplies. The organs typically at risk are the brain, the kidneys, the intestine, and the extremities.

Several arterial filters have been designed for entrapment of embolic debris generated during surgical procedures. In some of the designs, the arterial cannula accommodates a filter in its lumen. Unfortunately, the lumen of the arterial cannula is  
30 sometimes occluded by the filter, causing impairment of arterial blood flow and pressure drop across the cannula.

Thus, there is a need for new devices and methods that are capable of

delivering oxygenated blood to and capturing embolic material within a patient's cardiovascular tissue during surgical procedures.

### Summary of the Invention

5           The present invention provides a cannula for placement in a patient's vessel. It will be understood that although the cannula is most useful in performing cannulation in arteries, *e.g.*, the aorta, the carotid artery, the iliac artery, and the femoral artery, it is also suitable for placement in veins, *e.g.*, the inferior vena cava. In a first embodiment, the cannula comprises an elongate member having first and second lumens  
10 communicating with a proximal end and a distal end. The first lumen is adapted for perfusion of blood, whereas the second lumen is adapted to receive a filter wire. The effective diameter of the second lumen is smaller than that of the first lumen. The wall separating the first and second lumens is perforated to allow communication of blood flow between the two lumens. In certain embodiments, the proximal end of the cannula  
15 is adapted for attachment to a bypass-oxygenator machine.

          In another embodiment, the distal end of the cannula is angled approximately 90° from the proximal end to facilitate positioning of the cannula inside a vessel. In certain embodiments, the angled distal region is flexible, so that the cannula assumes a linear configuration to facilitate its insertion into a vessel and returns  
20 to its preformed angled configuration after being positioned in the vessel. A suture flange may be mounted on a distal region of the cannula to secure the cannula onto a vessel. A hemostatic valve is included in the proximal end of the second lumen to prevent blood loss.

          In another embodiment, the proximal end of the second lumen also includes  
25 a mechanism for adjusting blood flow in the second lumen. A manometer included in the distal end of the cannula measures blood pressure downstream the cannula and provides feedback to the mechanism for controlling blood flow to the vessel.

          The invention also provides methods for cannulation of a vessel and protecting a patient from embolization using the cannula described above. During  
30 cardiopulmonary bypass, for example, the filter or the occluding device is first placed in a collapsed state and inserted through an incision into the patient's aorta. The filter

or the occluding device is expanded to capture embolic material, including air, thrombi, calcium, atheromatous plaque, and/or tissue debris. The distal end and the second lumen of the cannula is inserted over the filter wire and advanced into the aorta.

Sutures may be placed on the suture flange to secure the cannula onto the aortic wall.

5 The proximal end of the cannula may then be attached to a bypass–oxygenator and oxygenated blood is infused into the aorta through the first lumen of the cannula to establish cardiopulmonary bypass. Blood pressure downstream the cannula is measured by an optional manometer mounted on the distal end of the cannula. Blood flow to the aorta can be controlled by adjusting a flow–controlling mechanism that may  
10 be included in the proximal end of the cannula. After the surgical procedure, the cannula is withdrawn from the aorta over the filter wire. The filter is collapsed. The filter and the captured embolic material are then removed from the aorta.

In an alternative method, an introducer is first inserted into the aorta. The filter, in a collapsed state, is then inserted into the lumen of the introducer and  
15 advanced into the aorta. After expansion of the filter, the introducer is removed from the aorta. The cannula is then inserted over the filter wire to position in the aorta.

It will be understood that there are several advantages associated in using the devices and methods disclosed herein for maintaining vascular perfusion and preventing embolic complication during cardiovascular procedures. For example, (1)  
20 the filter is adapted for temporary placement in a patient’s artery or vein and can be replaced during a procedure without removing the cannula; (2) the cannula may be adapted for attachment to a bypass–oxygenator; (3) the inclusion of a separate filter lumen prevents occlusion of the perfusion lumen by the filter; (4) the inclusion of a perforated wall between the perfusion and filter lumens reduces the pressure drop  
25 through the cannula; (5) the cannula provides aortic cannulation during cardiopulmonary bypass in addition to providing protection from distal embolization; and (6) the devices minimize crowding of the surgical field during minimally invasive cardiovascular procedures.

### 30 Brief Description of the Drawings

Fig. 1 depicts an embodiment of a cannula having a perforated filter lumen.

Fig. 2A depicts another embodiment of the cannula having an angled distal

region.

Fig. 2B depicts a cross-sectional view of the cannula of Fig. 2A through section line B-B

5 Fig. 2C depicts a cross-sectional view of the cannula of Fig. 2A through section line C-C.

Fig. 3A depicts a cross-sectional view of another embodiment of the cannula having an oval-shaped filter lumen.

10 Fig. 3B depicts a cross-sectional view of another embodiment of the cannula having a plurality of perforations between the blood lumen and filter lumen in a cross section.

Fig. 3C depicts a cross-sectional view of another embodiment of the cannula having the filter lumen located in the center of the cannula.

Fig. 4A depicts a blood filter inserted into an artery.

15 Fig. 4B depicts the cannula of Fig. 2A inserted over the filter wire of Fig. 4A.

Fig. 5A depicts another embodiment of the cannula having a second perforated tubular member nested within the filter lumen.

Fig. 5B depicts a cross-sectional view of the cannula in Fig. 5A through section line B-B.

20 Fig. 5C depicts clockwise rotation of the nested tubular member of Fig. 5B allowing partial alignment between apertures on the perforated wall and the nested tubular member.

25 Fig. 5D depicts further clockwise rotation of the nested tubular member of Fig. 5C allowing misalignment between apertures on the perforated wall and the nested tubular member.

Fig. 6 depicts the cannula and filter of Fig. 4B inserted in the ascending aorta during cardiopulmonary bypass.

### Detailed Description

30 The devices and methods disclosed herein are adapted for temporary placement in a patient's artery or vein for entrapment and removal of embolic debris.

The cannulas are particularly useful in cardiovascular surgeries for maintaining arterial perfusion during cardiopulmonary bypass and preventing distal embolization to peripheral organs. Fig. 1 depicts an embodiment of the cannula that comprises an elongate member having blood lumen 20 and filter lumen 25 extending to distal end 15. Lumen 20, adapted for infusion of oxygenated or deoxygenated blood, communicates with proximal end 12 which is adapted for attachment to a bypass-oxygenator. Lumen 25 is adapted for receiving a filter wire, and communicates proximally with proximal end 26 that optionally includes hemostatic valve 30, which may consist of a duckbill, o-ring, or other suitable seals or valve arrangements. Wall 35, which separates lumens 20 and 25, is perforated to allow communication of blood flow between the two lumens. The effective diameter of lumen 20 is therefore greater than the diameter of lumen 20 because it includes the area occupied by lumen 25.

Fig. 2A depicts another embodiment of the cannula having distal end 15 angled at approximately 90° relative to its proximal end. This configuration allows the cannula to be positioned within the region of interest to better fit the vessel geometry and thereby facilitate blood delivery and filter deployment in a vessel. In certain embodiments, the cannula includes flexible distal region 40 that allows the cannula to assume a linear configuration to facilitate insertion into a vessel. After insertion, the cannula returns to its preformed angled configuration within the vessel. Flange 44, mounted on a distal region of the cannula, allows placement of sutures to secure the cannula onto the vessel wall.

Cross-sectional views of wall 35 at different location on the cannula are depicted in Figs. 2B and 2C. Wall 35 includes apertures 33, which allow flow between lumens 20 and 25. In this embodiment, blood flows between the two lumens through aperture 33 in the cross-sectional view of the cannula depicted in Fig. 2C. In Fig. 3A, wall 35 includes three apertures 33. The wall may include 2, 3, 4, 5, 6, 7, 8, or any other number of apertures suitable to allow blood flow between the two lumens. Fig. 3B depicts another embodiment of wall 35 separating lumens 20 and 25, such that the cross-sectional configuration of lumen 25 approximates an oval or elliptical shape. The cross-sectional configuration of lumen 25 may also take on other suitable shapes, *e.g.*, circular, square, or rectangular. In Fig. 3C, lumen 25 is located in the center of

lumen 20. In other embodiments, lumen 25, shaped to receive a filter, may be located anywhere within lumen 20.

In using the filter and cannula of Fig. 2A during cardiovascular procedures, the filter, in a collapsed state, is first inserted directly through an incision on a vessel and advanced to the region of interest. For example, in performing coronary artery bypass grafting surgery, filter 50 is deployed downstream atheromatous lesion 101 to capture embolic debris as depicted in Fig. 4A. To establish cardiopulmonary bypass, the distal end of the cannula is inserted over filter wire 55 through lumen 25 into the aorta as depicted in Fig. 4B. Sutures are placed on flange 44 to secure the cannula onto the aortic wall. The proximal end of the cannula is attached to a bypass-oxygenator. Oxygenated blood is then infused through lumen 20 of the cannula downstream the ascending aorta to maintain peripheral perfusion while filter 50 provides protection against distal embolization. After completion of the procedure, cardiopulmonary bypass is discontinued, the cannula is removed from the aorta, and filter 50 is collapsed. The filter and the captured embolic material, *e.g.*, air, fluid, thrombi, calcium, atheromatous plaque, and/or tissue debris, generated during the procedure, are then removed from the aorta. Alternatively, the cannula and collapsed filter 50 are concomitantly removed from the aorta.

In an alternative method, an introducer (not shown) is first inserted through the aorta. The collapsed filter 50 is inserted through the lumen of the introducer to position in the ascending aorta. After expansion of the filter, the introducer is removed from the aorta, and the cannula is then introduced over filter wire 55 into the aorta as described above. In another alternative method, the collapsed filter is first inserted in the lumen of an introducer. The filter/introducer is then inserted through an incision into the aorta. After deployment of the filter, the introducer is removed and the cannula is inserted over the filter wire into the aorta.

The construction and use of expansion means and associated filter mesh have been thoroughly discussed in earlier patents including Barbut et al., U.S. Patent Nos. 5,662,671; 5,769,816; 5,989,281; 6,086,605; 6,136,016; 6,117,154; 6,090,097; 6,048,331; 5,662,671; Kaganov et al., U.S. Patent No. 5,876,367, Maahs, U.S. Patent No. 5,846,260, Ambrisco et al., U.S. Patent No. 6,007,557, Tsugita, U.S. Patent No. 6,042,598, and Addis, U.S. Patent No. 6,083,239, and the contents of each of these

prior patents are expressly incorporated herein by reference in their entirety.

Fig. 5A depicts another embodiment of the cannula which includes a second perforated elongate tubular member 36 nested within filter lumen 25. Tubular member 36 also has a plurality of apertures 33 which are of the same shape and size as on wall 35. Tubular member 36 can be rotated clockwise or counterclockwise within lumen 25 such that apertures 33 on wall 35 and tubular member 36 overlap. This design allows regulation of blood flow between lumens 20 and 25. According to Fig. 5B, tubular member 36 is rotated such that apertures 33 on the tubular member align with apertures 33 on wall 35, thereby allowing maximal blood flow between the two lumens. When tubular member 36 is rotated clockwise, apertures 33 on tubular member 36 are partially aligned with apertures 33 on wall 35, thereby allowing partial blood flow between the two lumens as depicted in Fig. 5C. As tubular member 36 is further rotated clockwise, apertures 33 on tubular member 36 and wall 35 are misaligned, thereby allowing no blood flow between the two lumens. In this way, blood flow between the arterial return lumen and filter lumen can be controlled and varied. In certain embodiments, the cannula includes apertures 33 on the entire length of wall 35 and tubular member 36. In other embodiments, only certain segment(s) of the cannula include apertures.

The devices and methods described above can be used in open or minimally invasive cardiovascular surgeries. During coronary artery bypass grafting or valvular surgeries, for example, the cannula and filter 50 are deployed in ascending aorta 100 as depicted in Fig. 6. Filter wire 55 is insertable through lumen 25. The proximal end of lumen 25 includes hemostatic valve 30, which minimizes blood loss. Proximal end 12 of the cannula is attached to a bypass-oxygenator which receives deoxygenated blood from a vein, *e.g.*, the inferior vena cava, oxygenates the blood, and returns the oxygenated blood to the aorta through lumen 20. The distal end of the cannula may include manometer 70, which measures blood pressure downstream of the cannula. The proximal end of the manometer is attached to pressure monitor 75 that displays blood pressure readings. Using the mechanism and methods described in Fig. 5, blood flow between lumens 20 and 25 through the apertures in wall 35 and the nested tubular member can be regulated by rotation of the nested tubular member with respect to wall 35.



The length of the cannula will generally be between 10 and 100 centimeters for aortic use, preferably approximately between 20 and 50 centimeters. The outer diameter of the cannula will generally be between 0.5 and 1.5 centimeters, preferably approximately between 0.8 and 1.2 centimeters. The inner diameter of the arterial lumen will generally be between 2 and 14 millimeters, preferably approximately between 4 and 7 millimeters. The inner diameter of the filter lumen will generally be between 1 and 7 millimeters, preferably approximately between 3 and 5 millimeters. The filter will be capable of expanding to an outer diameter of at least 0.2 centimeters, more preferably at least 0.5 centimeters, more preferably at least 1.0 centimeters, more preferably at least 1.5 centimeters, more preferably at least 2.0 centimeters, more preferably at least 2.5 centimeters, more preferably at least 3.0 centimeters, more preferably at least 3.5 centimeters, more preferably at least 4.0 centimeters, more preferably at least 4.5 centimeters, more preferably at least 5.0 centimeters. The filter will be capable of contracting to an outer diameter of between 0.05 and 2.0 millimeters, preferably approximately between 0.8 and 1.2 millimeters. These ranges cover suitable diameters for both pediatric and adult use. The foregoing ranges are set forth solely for the purpose of illustrating typical device dimensions. The actual dimensions of a device constructed according to the principles of the present invention may obviously vary outside of the listed ranges without departing from those basic principles.

Although the foregoing invention has, for the purposes of clarity and understanding, been described in some detail by way of illustration and example, it will be obvious that certain changes and modifications may be practiced which will still fall within the scope of the appended claims. Moreover, it will be understood that each and every feature described for any given embodiment or in any reference incorporated herein, can be combined with any of the other embodiments described herein.

What is claimed is:

1. A cannula, comprising:  
an elongate tubular member having a proximal end, a distal end, a first lumen extending from the proximal end to the distal end, and a second lumen extending  
5 from the proximal end to the distal end, the second lumen adapted to receive a filter wire; and  
a perforated wall separating the first lumen and the second lumen, the perforated wall having perforations that allow blood flow, wherein an effective diameter of the first lumen is greater than a diameter of the first lumen.
- 10 2. The cannula of claim 1, wherein the distal end is angled approximately 90° from the proximal end.
3. The cannula of claim 1, further comprising a filter wire extending through the second lumen.
4. The cannula of claim 1, wherein the proximal end of the cannula  
15 further comprises a fitting for attachment to a bypass-oxygenator machine.
5. The cannula of claim 1, further comprising suture flange mounted on a distal region of the cannula.
6. The cannula of claim 1, further comprising a hemostatic valve in the proximal end of the second lumen.
- 20 7. The cannula of claim 1, further comprising a flow-controlling mechanism in the proximal end.
8. The cannula of claim 7, wherein the flow-controlling mechanism is a valve.

9. The cannula of claim 1, further comprising a manometer mounted on the distal end.
10. The cannula of claim 2, wherein the angled distal region is flexible.
- 5 11. A method for open surgical arterial cannulation, comprising the steps of:
- inserting a filter wire into an artery;  
expanding the filter;  
advancing a cannula over the filter wire; and  
10 infusing blood through the cannula into the artery.
12. The method of claim 11, wherein the artery is an aorta.
13. The method of claim 11, wherein the artery is a carotid artery.
14. The method of claim 11, further comprising the step of inserting an introducer into the artery before the step of inserting the filter wire.
- 15 15. The method of claim 14, further comprising the step of removing the introducer after inserting the filter wire.
16. The method of claim 11, wherein the filter is expanded after the step of advancing the cannula over the filter wire.
17. The method of claim 11, further comprising the step of  
20 performing a surgical procedure upstream of the cannula.

18. The method of claim 17, wherein the surgical procedure is coronary artery bypass graft.

19. The method of claim 17, wherein the surgical procedure is valvular repair.

5 20. The method of claim 11, further comprising the step of withdrawing the filter wire into the cannula.

21. The method of claim 20, further comprising the step of removing the cannula and filter from the artery.

10 22. The method of claim 11, further comprising the step of inserting an introducer into the artery over the wire of the filter wire.

23. The method of claim 22, further comprising the step of removing the cannula while maintaining the expanded filter in the artery.

24. The method of claim 11, further comprising the step of collapsing and removing the filter.

15 25. The method of claim 24, further comprising the step of removing the introducer.

20 26. The method of claim 11, wherein the filter wire further comprises a slideable sheath covering the collapsed filter, and wherein the method further comprises the step of removing the sheath to release the filter before expanding the filter.

27. The method of claim 26, further comprising the step of advancing a sheath over the filter to capture the filter and debris contained in the filter before removing the filter from the vessel.

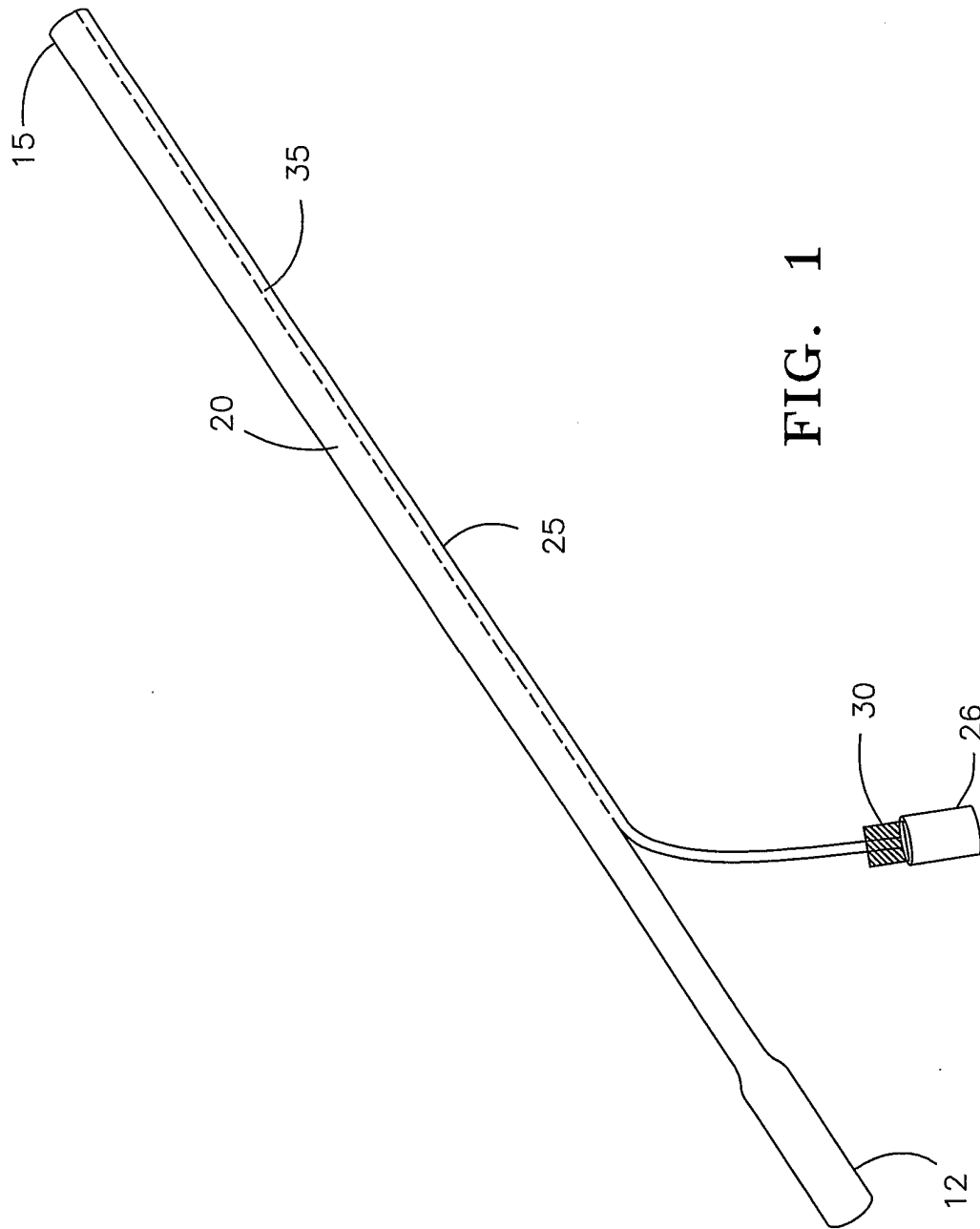

FIG. 1

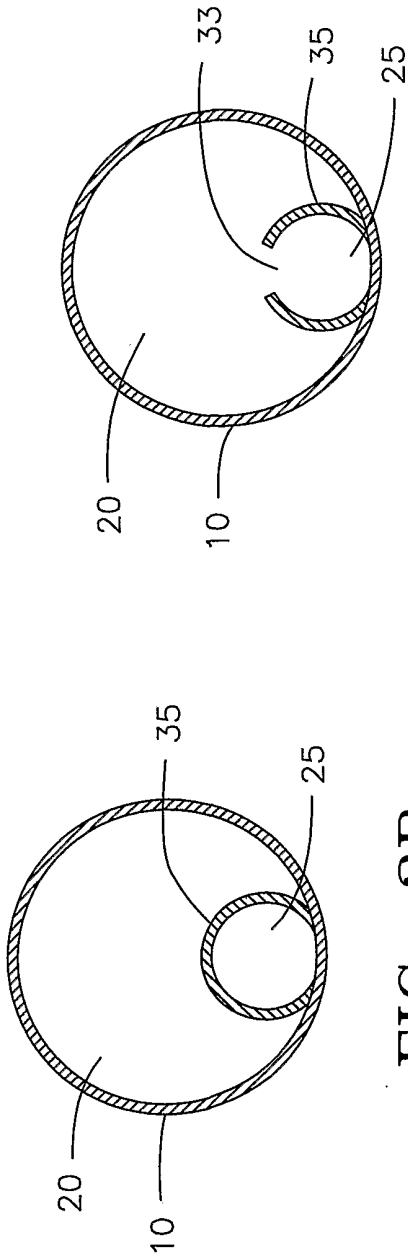

FIG. 2B

FIG. 2C

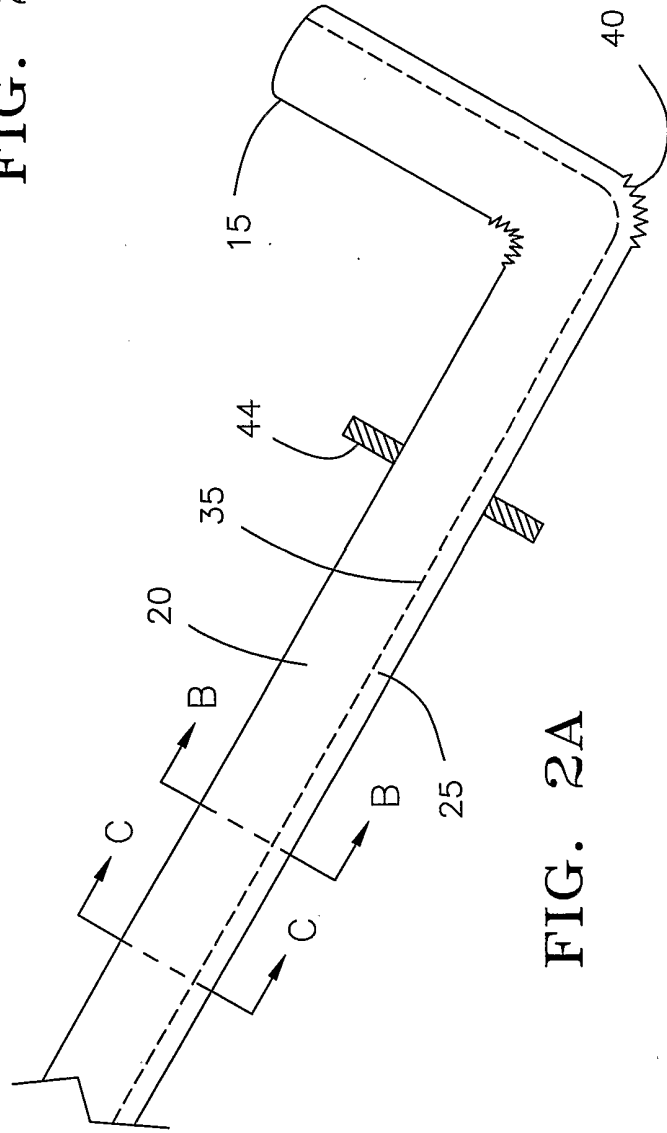

FIG. 2A

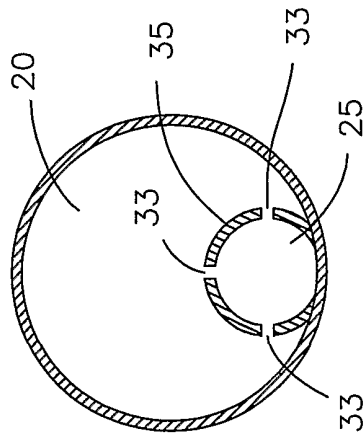
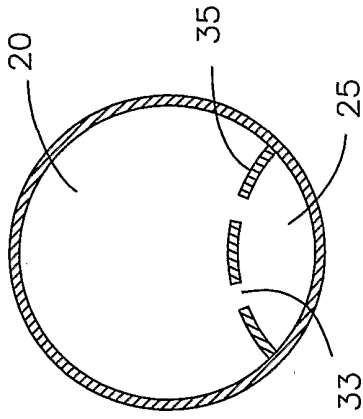
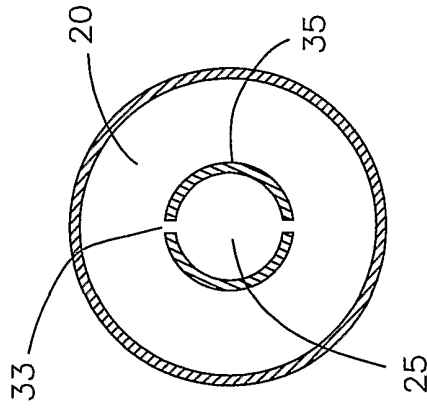

FIG. 3A

FIG. 3B

FIG. 3C



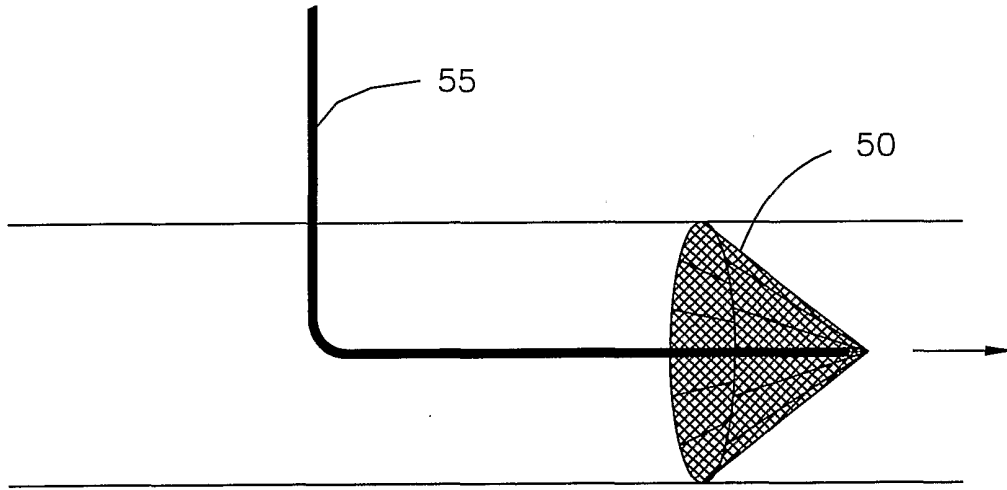

FIG. 4A

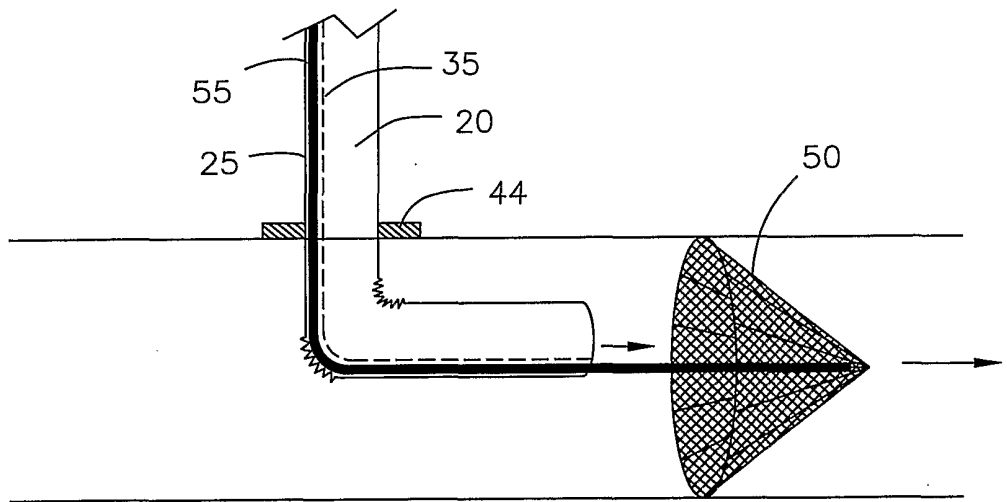

FIG. 4B

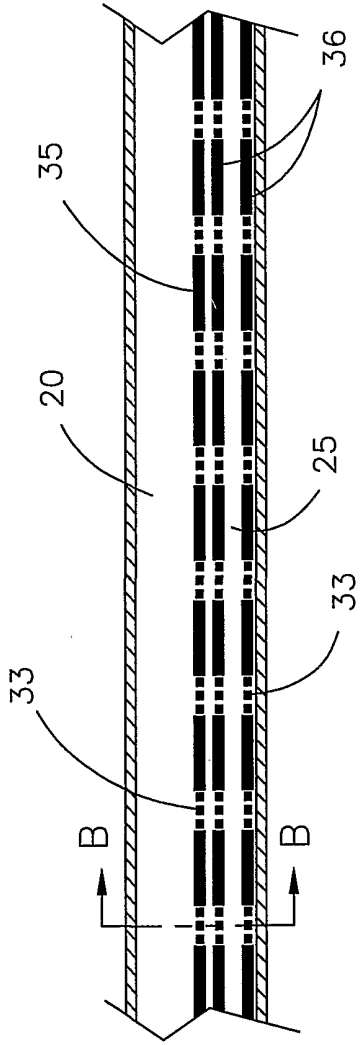

FIG. 5A

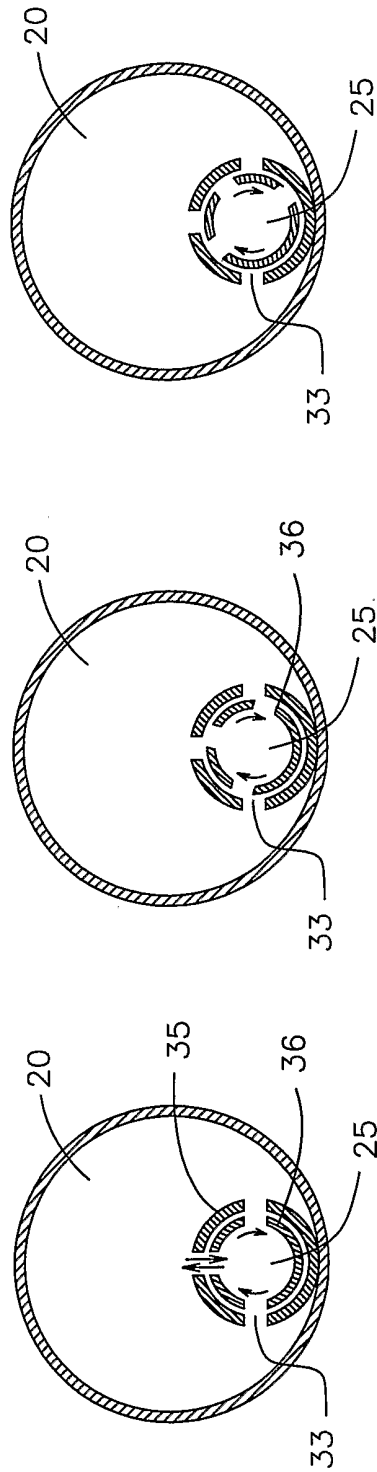

FIG. 5B

FIG. 5C

FIG. 5D

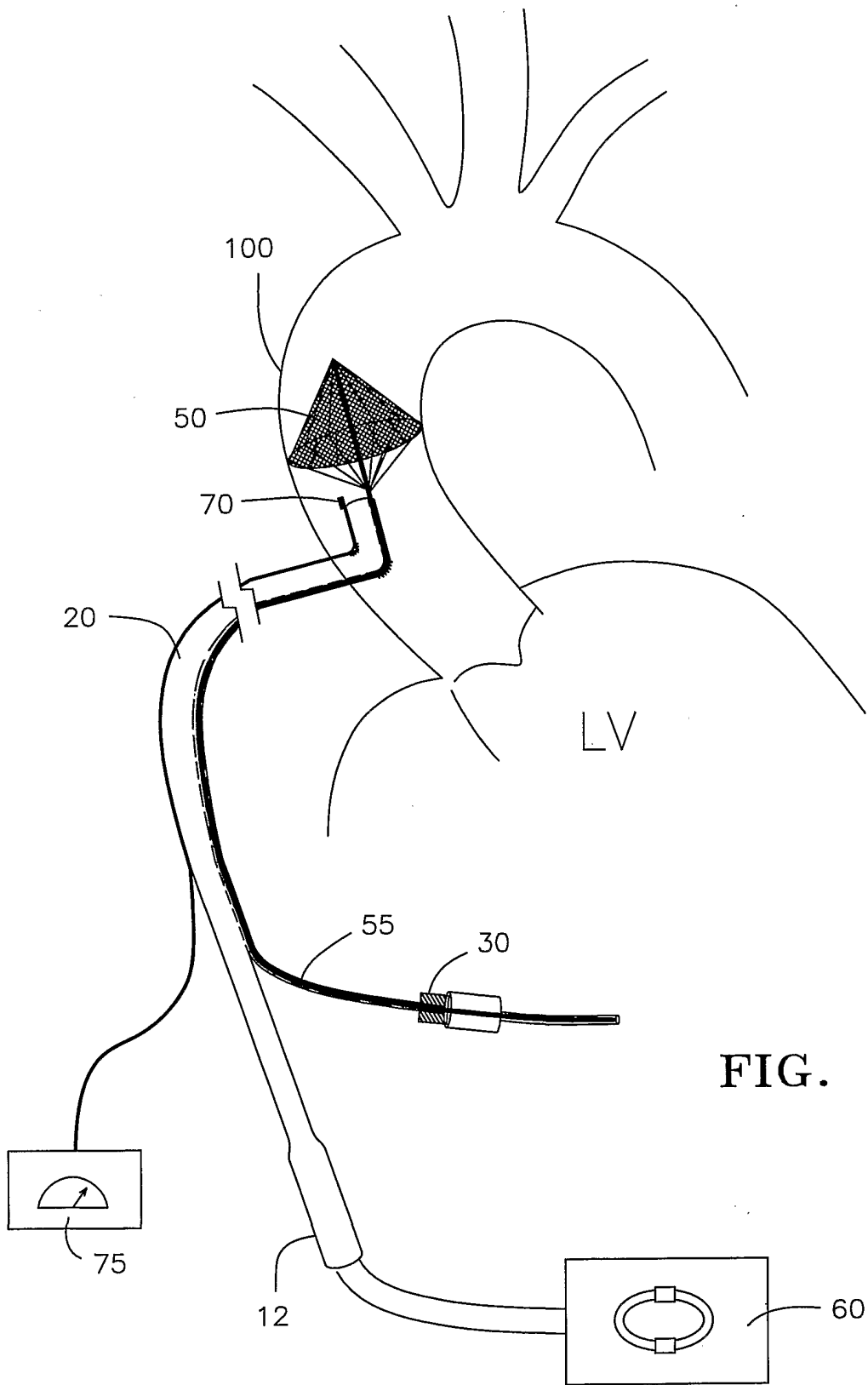

FIG. 6

INTERNATIONAL SEARCH REPORT

International application No.  
PCT/US02/00700

**A. CLASSIFICATION OF SUBJECT MATTER**  
 IPC(7) :A61M 29/00, 25/00, 5/00; A61F 11/00  
 US CL :606/108, 200; 604/264  
 According to International Patent Classification (IPC) or to both national classification and IPC

**B. FIELDS SEARCHED**  
 Minimum documentation searched (classification system followed by classification symbols)  
 U.S. : 606/108, 200; 604/264

Documentation searched other than minimum documentation to the extent that such documents are included in the fields searched

Electronic data base consulted during the international search (name of data base and, where practicable, search terms used)  
 EAST

**C. DOCUMENTS CONSIDERED TO BE RELEVANT**

Category*	Citation of document, with indication, where appropriate, of the relevant passages	Relevant to claim No.
A, E	US 6,350,252 B2 (Ray et al.) 26 February 2002, see figs. 14	1-27
A	US 6,090,097 A (Barbut et al.) 18 July 2000, see fig. 43	1-27
A	US 6,056,723 A (Donlon) 2 May 2000, see fig. 1	1-27
A	US 5,928,181 A (Coleman et al.) 27 July 1999, see fig. 11	1-27

Further documents are listed in the continuation of Box C.  See patent family annex.

* Special categories of cited documents:	"T" later document published after the international filing date or priority date and not in conflict with the application but cited to understand the principle or theory underlying the invention
"A" document defining the general state of the art which is not considered to be of particular relevance	"X" document of particular relevance; the claimed invention cannot be considered novel or cannot be considered to involve an inventive step when the document is taken alone
"E" earlier document published on or after the international filing date	"Y" document of particular relevance; the claimed invention cannot be considered to involve an inventive step when the document is combined with one or more other such documents, such combination being obvious to a person skilled in the art
"L" document which may throw doubts on priority claim(s) or which is cited to establish the publication date of another citation or other special reason (as specified)	"G" document member of the same patent family
"O" document referring to an oral disclosure, use, exhibition or other means	
"P" document published prior to the international filing date but later than the priority date claimed	

Date of the actual completion of the international search 27 MARCH 2002	Date of mailing of the international search report <b>11 JUN 2002</b>
Name and mailing address of the ISA/US Commissioner of Patents and Trademarks Box PCT Washington, D.C. 20231 Facsimile No. (703) 305-3230	Authorized officer <i>(Signature)</i> (JACKIE) TAN-UYEN CHH NO Telephone No. (703) 306-3421