



(51) International Patent Classification:

A61J 9/00 (2006.01) B65D 23/00 (2006.01)
A61J 9/08 (2006.01) B65D 23/04 (2006.01)
B05B 11/00 (2006.01) B65D 25/04 (2006.01)
B65B 1/04 (2006.01)

(21) International Application Number:

PCT/US2016/036615

(22) International Filing Date:

9 June 2016 (09.06.2016)

(25) Filing Language:

English

(26) Publication Language:

English

(30) Priority Data:

14/736,697 11 June 2015 (11.06.2015) US

(71) Applicant: REPLENISH BOTTLING, LLC [US/US];
1086 S. Fairfax Ave., Los Angeles, California 90019 (US).

(72) Inventor: FOSTER, Jason E.; 1086 Fairfax Ave., Los Angeles, California 90019 (US).

(74) Agent: KLEINBERG, Marvin H.; 1875 Century Park E., Suite 1150, Los Angeles, California 90067 (US).

(81) Designated States (unless otherwise indicated, for every kind of national protection available): AE, AG, AL, AM, AO, AT, AU, AZ, BA, BB, BG, BH, BN, BR, BW, BY, BZ, CA, CH, CL, CN, CO, CR, CU, CZ, DE, DK, DM, DO, DZ, EC, EE, EG, ES, FI, GB, GD, GE, GH, GM, GT, HN, HR, HU, ID, IL, IN, IR, IS, JP, KE, KG, KN, KP, KR, KZ, LA, LC, LK, LR, LS, LU, LY, MA, MD, ME, MG, MK, MN, MW, MX, MY, MZ, NA, NG, NI, NO, NZ, OM, PA, PE, PG, PH, PL, PT, QA, RO, RS, RU, RW, SA, SC,

[Continued on next page]

(54) Title: MIXING BOTTLE CAPABLE OF DISASSEMBLY

(57) Abstract: A mixing container is designed to be disassemblable so that its component parts can be thoroughly cleaned. The container has a removable base which includes a valve assembly through which fluid concentrates can be added from a replaceable pod. In some embodiments, a measuring cup is a part of the removable base. In other embodiments, a measuring receptacle is integrated with the container.

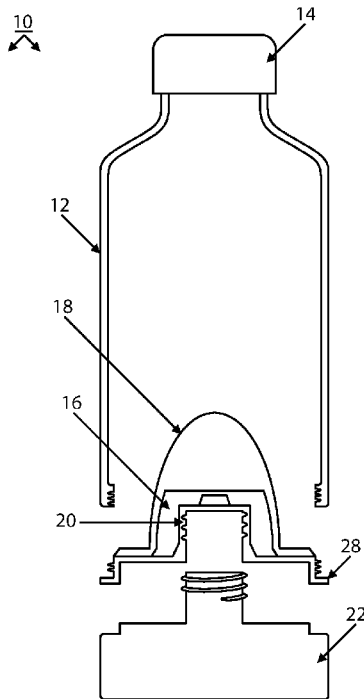

FIG. 1B



SD, SE, SG, SK, SL, SM, ST, SV, SY, TH, TJ, TM, TN, TR, TT, TZ, UA, UG, US, UZ, VC, VN, ZA, ZM, ZW.

(84) Designated States (unless otherwise indicated, for every kind of regional protection available): ARIPO (BW, GH, GM, KE, LR, LS, MW, MZ, NA, RW, SD, SL, ST, SZ, TZ, UG, ZM, ZW), Eurasian (AM, AZ, BY, KG, KZ, RU, TJ, TM), European (AL, AT, BE, BG, CH, CY, CZ, DE, DK, EE, ES, FI, FR, GB, GR, HR, HU, IE, IS, IT, LT, LU, LV, MC, MK, MT, NL, NO, PL, PT, RO, RS, SE, SI, SK, SM, TR), OAPI (BF, BJ, CF, CG, CI, CM, GA, GN, GQ, GW, KM, ML, MR, NE, SN, TD, TG).

Declarations under Rule 4.17:

— as to the identity of the inventor (Rule 4.17(i))

- as to applicant's entitlement to apply for and be granted a patent (Rule 4.17(ii))
- as to the applicant's entitlement to claim the priority of the earlier application (Rule 4.17(iii))
- of inventorship (Rule 4.17(iv))
- as to non-prejudicial disclosures or exceptions to lack of novelty (Rule 4.17(v))

Published:

- with international search report (Art. 21(3))
- with amended claims (Art. 19(1))

PATENT APPLICATION

MIXING BOTTLE CAPABLE OF DISASSEMBLY

Field of the Invention:

[0001] The present invention consists of a self-contained mixing and dispensing container having multiple attachment options for sealing and closing that can be disassembled for cleaning. The attachment options can be, but are not limited to, threads, snap fits, or clasps.

Description of the Related Art:

[0002] Currently, refillable/reusable mixer bottles are comprised of two or more chambers, a mechanism by which fluid may be transferred from one chamber to the other, and a mechanism by which to dispense or deliver the mixture. Openings in each of the chambers allow for refilling the chambers with an appropriate fluid.

[0003] The problem with existing mixer bottles is that the mixing chamber cannot be disassembled and reassembled for cleaning and other desired or necessary tasks. Without disassembly, the user is unable to thoroughly wash the chambers, especially if they have been used with concentrated beverages, liquid nutrition or other solutions that would require thorough rinsing and cleaning before reuse with other fluids.

BRIEF DESCRIPTION OF INVENTION

[0004] The present invention provides a reusable mixing bottle or container that can be disassembled for cleaning. The base of the bottle is removable from the bottle. For those models with an interior measuring cup adjacent the base, that

element is also removable . Alternatively, there may be a pivot around which the base can rotate so that it is not completely separated from the bottle. While in the preferred embodiments, the mixing bottle and its components may be made of plastics, for some uses it may be preferable to fabricate the bottle or its component parts of a metal such as aluminum or stainless steel, or glass, depending upon the intended use. The use of a metal or glass can result in a longer lasting bottle and reduce the use of plastics.

[0005] The base can be coupled to the bottle with a friction or other fit to hold the base in place. The base may also have a depending shroud which can serve as a stand for the bottle. The shroud portion is circumferential so that a pod can be coupled to the base. In some embodiments, the base and bottle can be provided with threads with a gasket in the base so that the base can be coupled to the bottle in a leakproof relationship. Alternatively, a latch may be provided to hold the base in place. Releasing the latch permits the base to swivel about the pivot.

[0006] Accordingly, it is an object of the invention to provide multiple ways to take apart and reassemble the mixing chamber of a reusable dispenser. In doing so, the user has the option to wash the component elements in the dishwasher or by hand.

[0007] The novel features which are characteristic of the invention, both as to structure and method of operation thereof, together with further objects and advantages thereof, will be understood from the following description, considered in connection with the accompanying drawings, in which the preferred embodiment of the invention is illustrated by way of example. It is to be expressly understood, however, that the drawings are for the purpose of illustration and description only, and they are not intended as a definition of the limits of the invention.

Brief Description Of The Drawings

[0008] Figure 1 including Figures 1a and 1b shows, respectively, the fully assembled and disassembled refillable/reusable mixing and dispensing container which utilizes a press fit closure;

[0009] Figure 2. including Figures 2a and 2b shows an alternative embodiment of the fully assembled and disassembled container;

[0010] Figure 3, including Figures 3a and 3b shows yet an another alternative embodiment of an assembled and disassembled container utilizing a latch closure and;

[0011] Figure 4. shows another alternative embodiment of the container utilizing a latch closure; and

[9912] Figure 5 is an idealized side sectional view of yet another alternative embodiment of a separable mixing container.

Detailed Description of Drawings

[0013] Turning first to Figure 1 which includes Figures 1a and 1b, there is shown an assemblable and disassemblable container 10 according to the present invention. The container 10 includes a first mixing chamber 12 with a removable cap 14. At the base of the chamber 12 is a valve assembly 16 with an integral mixing cup 18. In this embodiment, the valve assembly 16 includes a threaded portion 20 to which a removable pod 22 can be attached. The pod 22 contains a liquid concentrate which when properly diluted becomes the contents of the mixing chamber 12. When ready for use, the cap 14 is removed and replaced with an appropriate dispensing mechanism (not shown) which may be a spray nozzle. Alternatively, if the diluted contents are a beverage, then the cap 14 is removed to gain access to the beverage.

[0014] In this embodiment, the valve assembly 18 has a peripheral gasket 24 which can sealingly engage the base 26 of the mixing chamber 12 with a secure liquid-tight press fit. A tab 28 adjacent the gasket 24 assists in the removal of the valve assembly 18 from the base 26 of the mixing chamber 12.

[0015] When it is desired to disassemble the container 10, the tab 28 can be used to separate the valve assembly 18 and its gasket 24 from the base 26 of the mixing chamber 12. Both the valve assembly 18 and the mixing chamber 12 can now be separately cleaned of the previous contents and prepared for reuse.

[0016] Turning next to Figure 2 which includes Figures 2a and 2b, there is shown assembled and disassembled, an alternative embodiment of a mixing container 40 according to the present invention. As with the embodiment of Figure 1, the container 40 includes a mixing chamber 42 with a removable cap 44.

[0017] In lieu of a mixing cup, the mixing chamber 42 is fitted with a mixing reservoir 46 into which a concentrated liquid is dispensed. To accomplish this, a valve assembly 48 is eccentrically fitted to the base 50 of the mixing chamber 42. The valve assembly 48 is fitted with a peripheral gasket 52 that enables the valve assembly 48 to sealingly engage the base 50 of the mixing chamber 42.

[0018] A peripheral flange (not shown) may be provided to the valve assembly 48 to help in the assembly and disassembly process. As shown, the eccentric placement of the valve assembly 48 allows the use of the reservoir 46 in place of a centrally located measuring cup as in the embodiment of Figure 1.

[0019] Turning next to Figure 3, including Figures 3a and 3b, there is shown yet another alternative embodiment of a mixing bottle 60 according to the present invention. In this embodiment, the mixing bottle includes an upper mixing chamber 62 with an eccentrically placed spout 64 having a removable cap 66. In this

embodiment, a valve assembly 68 is centrally located and a reservoir 70 is also centrally located on the upper inner surface 72 of the mixing chamber 62.

[0020] The valve assembly 68 is coupled to the mixing chamber 62 by a hinge 74 and is secured to the mixing chamber 62 by a latch assembly 76. In this embodiment, releasing the latch assembly 76, enables the valve assembly 68 to rotate out of engagement with the mixing chamber 62, making the interior of the mixing chamber accessible for washing or otherwise cleaning.

[0021] Turning to Figure 4, there is shown an alternative embodiment to the embodiment of Figure 1 in which a latch closure 80 in combination with a hinge assembly 82 results in a modified container 10'. All other elements of container 10 of Figure 1 are present except for the sealing gasket 28. A tab 28' can facilitate the disengagement of the valve assembly 16' from the upper mixing chamber 12'.

[0022] Figure 5 shows another alternative embodiment of the present invention in side section. Here, a container 110 includes a mixing chamber 112. A valve assembly 116 and measuring cup 118 are part of a base element 126. The container 110 has peripheral threads 120 that can be engaged by a base element 126 which has a peripheral shroud 130 which can serve as a support stand for the container 110.. To assure a fluid tight seal, an internal gasket (not shown) can be provided between the base element 126 and the mixing chamber 112. A pod, 120, filled with liquid concentrate can be coupled to the valve assembly 116 for charging the cup 118 when necessary to refill the container 110.

[0023] Other embodiments and variations on the embodiments will occur to those skilled in the art within the scope of the present invention. Accordingly, the invention should be limited only by the scope of the claims appended below.

What is claimed as new is:

CLAIMS

1. Apparatus for dispensing liquids comprising:
 - a. A first container for storing liquids to be dispensed;
 - b. A measuring receptacle adapted to be filled in said container and positioned to receive a liquid concentrate;
 - c. A valve assembly adapted to be connected to said first container and aligned with said measuring receptacle so that liquids passing through said valve assembly are directed to said measuring receptacle;

2. The apparatus of Claim 1, further comprising:
 - d. A source of liquid concentrate adapted to connect to said valve assembly for supplying liquid concentrate to said measuring receptacle.

3. The apparatus of Claim 1 wherein said measuring receptacle is integral with a side wall of said first reservoir and said valve assembly is adjacent said side wall in alignment with said measuring receptacle.

4. The apparatus of Claim 1, wherein said valve assembly is connected to said first container with a hinge about which said valve assembly can rotate.

5. Apparatus for dispensing liquids comprising:

- a. A first container for storing liquids to be dispensed having an open bottom;
 - b. A measuring receptacle adapted to be filled in said container and positioned to receive a liquid concentrate;
 - c. A base assembly adapted to be coupled to said first container in a fluid tight relationship;
 - d. A valve assembly in said base assembly and aligned with said measuring receptacle so that liquids passing through said valve assembly are directed to said measuring receptacle; and
 - e. A shroud element, extending downward from said base assembly to form a support structure for said first container when it is combined with said base assembly.
6. Apparatus as in Claim 5 further including fastening means for coupling said base assembly to said first container.
 7. Apparatus as in Claim 6 wherein said fastening means include a hinge member.
 8. Apparatus as in Claim 6 wherein said fastening means include a latch mechanism for securing said base assembly to said first container.
 9. Apparatus as in Claim 6 wherein said fastening means include complementary screw threads on said base assembly and said first container.
 10. Apparatus as in Claim 6 wherein said fastening means include a gasket to provide a fluid tight seal when said base assembly and said first container are coupled together with a friction fit.

AMENDED CLAIMS

received by the International Bureau on 16 September 2016 (16.09.2016)

1

2

3 What is claimed is

4

5 1. Apparatus for dispensing liquids comprising the following separable elements:

6 a. ~~A~~ a first container having an open bottom for storing liquids to be dispensed;7 b. ~~A~~ a measuring receptacle adapted to be fitted to said container and positioned to
8 receive a liquid concentrate;9 c. ~~A~~ a valve assembly adapted to be connected to said first container and aligned
10 with said measuring receptacle so that liquids passing through said valve assembly are directed
11 to said measuring receptacle

12 whereby connecting said valve assembly to said first container provides a liquid tight seal.

13

14 2. The apparatus of Claim 1, further comprising:

15 d. a source of liquid concentrate adapted to connect to said valve assembly for supplying
16 liquid concentrate to said measuring receptacle.

17

18 Claim 3 is cancelled.

19

20 4. The apparatus of Claim 1, wherein said valve assembly is connected to said first
21 container with a hinge about which said valve assembly can rotate.

22

23

- 24 5. Apparatus for dispensing liquids comprising:
- 25 a. a first container for storing liquids to be dispensed having an open bottom;
- 26 b. a measuring receptacle adapted to be fitted to said container and positioned to
27 receive a liquid concentrate;
- 28 c. a base assembly adapted to be coupled to said first container in a fluid tight
29 relationship;
- 30 d. a valve assembly in said base assembly and aligned with said measuring
31 receptacle so that liquids passing through said valve assembly are directed to said measuring
32 receptacle; and
- 33 e. a shroud, extending downward from said base assembly to form a support
34 structure for said first container when it is combined with said base assembly.
- 35
- 36 6. Apparatus as in Claim 5 further including fastening means for coupling said base
37 assembly to said first container.
- 38
- 39 7. Apparatus as in Claim 6 wherein said fastening means include a hinge member.
- 40
- 41 8. Apparatus as in Claim 6 wherein said fastening means include a latch mechanism for
42 securing said base assembly to said first container.
- 43
- 44 9. Apparatus as in Claim 6 wherein said fastening means include complementary screw
45 threads on said base assembly and said first container.

46 10. Apparatus as in Claim 6 wherein said fastening means include a gasket to provide a fluid
47 tight seal when said base assembly and said first container are coupled together with a friction
48 fit.

49

50 11. Apparatus for dispensing liquids comprising the following separable components:

51 a. a first container having an open bottom for storing liquids to be dispensed;

52 b.. a measuring receptacle fitted to a side wall of said container to receive a liquid
53 concentrate

54 b. a valve assembly adapted to be connected to said open bottom of said first container to
55 form a liquid tight seal therewith and adjacent said side wall in alignment with said measuring
56 receptacle, and

57 c. fastening means for coupling said valve assembly to said open bottom in a liquid tight
58 relationship.

1/5

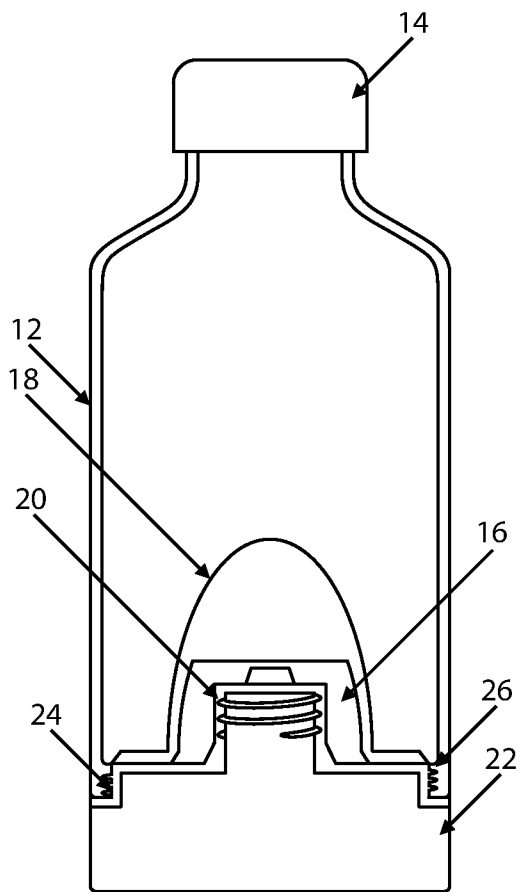

FIG. 1A

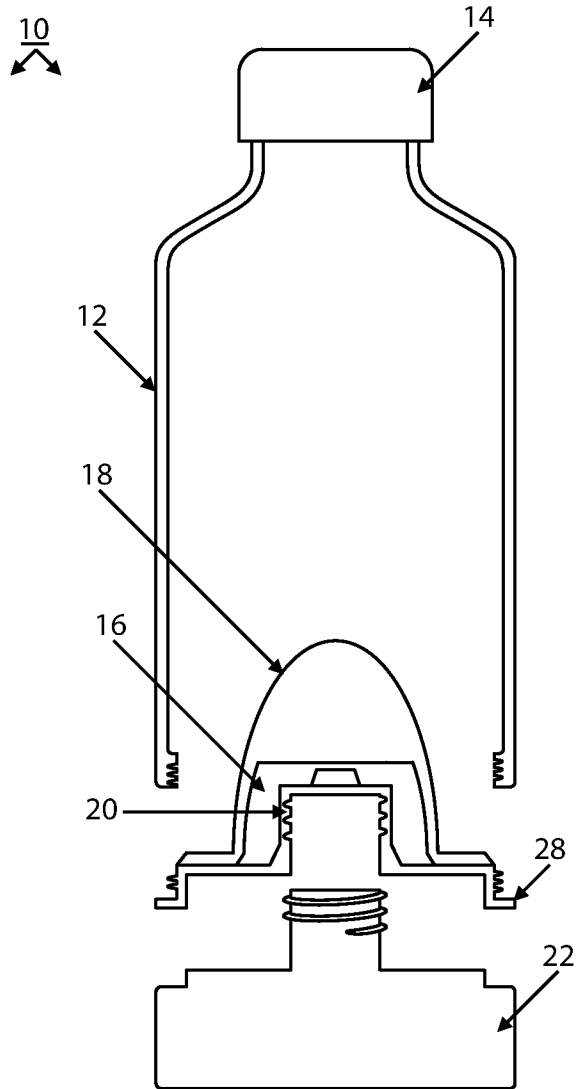

FIG. 1B

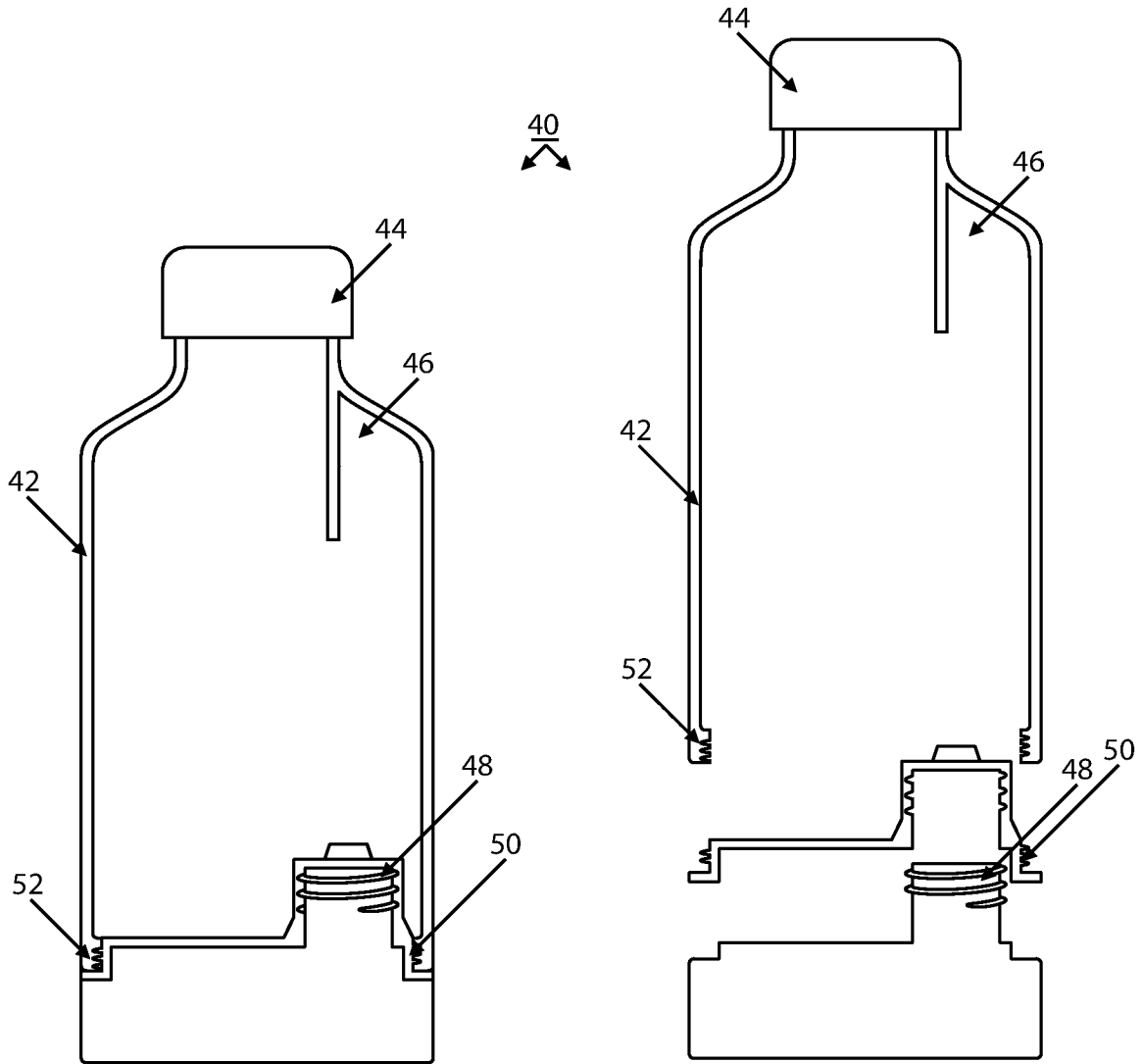

FIG. 2A

FIG. 2B

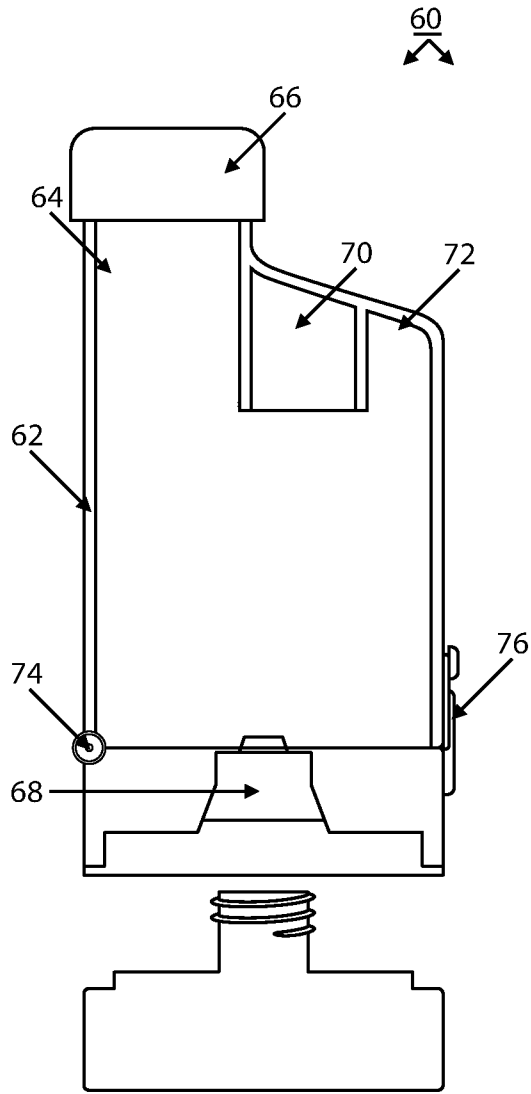

FIG. 3A

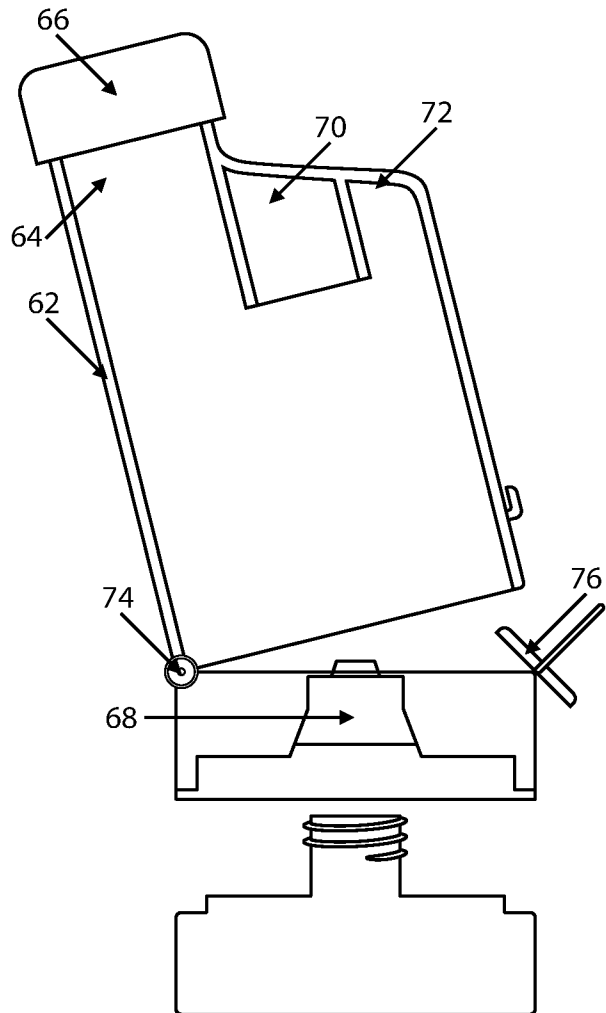

FIG. 3B

4/5

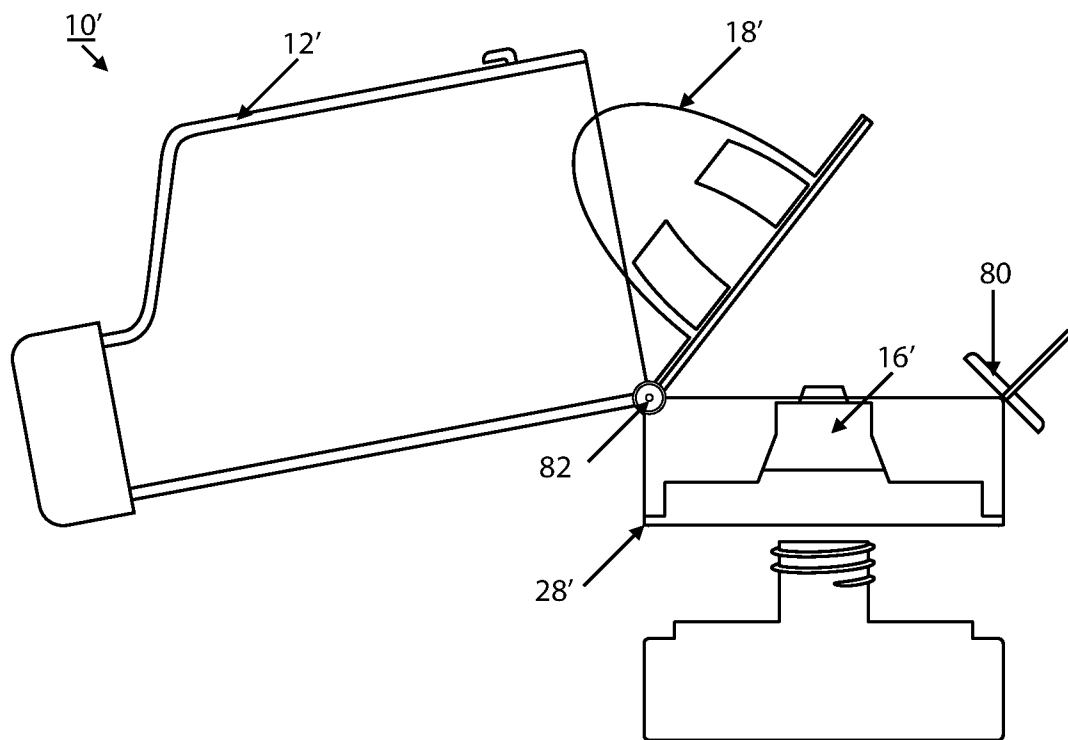

FIG. 4

5/5

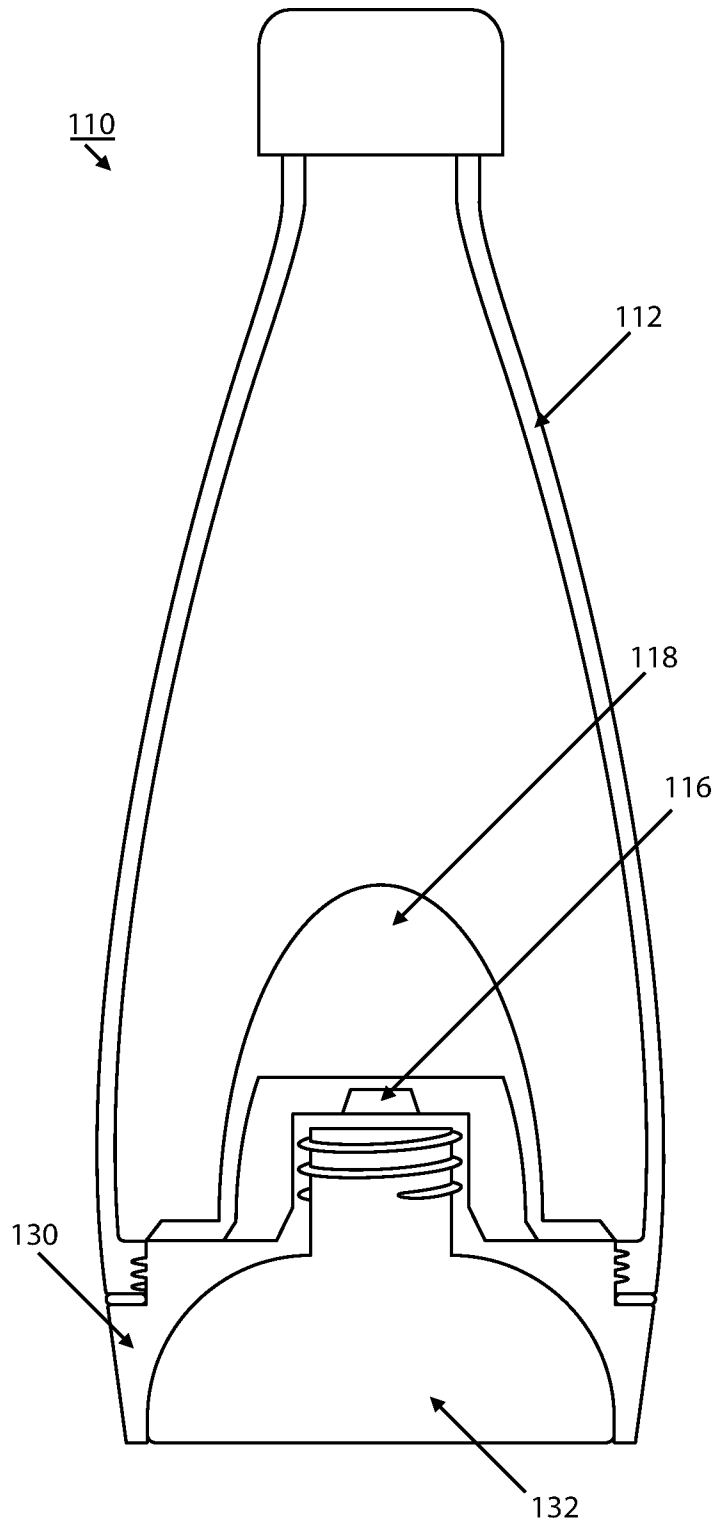

FIG. 5

INTERNATIONAL SEARCH REPORT

International application No.

PCT/US 16/36615

| A. CLASSIFICATION OF SUBJECT MATTER IPC(8) - A61J 9/00, A61J 9/08, B05B 11/00, B65B 1/04, B65D 23/00, B65D 23/04, B65D 25/04 (2016.01) CPC - A61J 9/00, A61J 1/2093, B05B 11/0056, B05B 11/0081, B05B 11/3057, B65D 23/04 According to International Patent Classification (IPC) or to both national classification and IPC | | |
|--|--|--|
| B. FIELDS SEARCHED Minimum documentation searched (classification system followed by classification symbols) IPC(8): A61J9/00 (2016.01) CPC: A61J9/00 Documentation searched other than minimum documentation to the extent that such documents are included in the fields searched IPC(8): A61J9/08, B05B11/00, B65B1/04, B65D23/00, B65D23/04, B65D25/04, B65D25/08, B65D37/00, B65D51/24, B65D51/28, B67B7/00, B67D5/38, B67D5/52, B67D5/56, B67D7/00, B67D7/06 (2016.01). CPC: A61J1/2093, B05B11/0056. Electronic data base consulted during the international search (name of data base and, where practicable, search terms used) PatBase. Google (Web, Patent, Scholar). Search Terms: Additive, Ampoule, Ampule, Baby, Bottle, Breastmilk, Canteen, Check, Compartment, Concentrate, Container, Crucible, Cup, Diluent, Dilute, Dose, Down, Fill, Flavorant, Formula, Gasoline, Hand, Hinge, Inject, Inside, Internal, Iodine, Kerosene, Lid, Liquid, Living, Measure, Medicine, Mix | | |
| C. DOCUMENTS CONSIDERED TO BE RELEVANT | | |
| Category* | Citation of document, with indication, where appropriate, of the relevant passages | Relevant to claim No. |
| X | US 7,850,043 B2 (FOSTER) 14 December 2010 (14.12.2010) Fig. 11A-B; col 10 ln 40-49, 63-65, col 11 ln 1-14 | 1-3 |
| A | | 4-10 |
| A | US 2010/0055252 A1 (MARINA et al.) 04 March 2010 (04.03.2010) Figs. 7A-B; paras [0029], [0040], [0061-2] | 1-10 |
| A | US 8,152,025 B2 (FOSTER) 10 April 2012 (10.04.2012) Fig. 5; col 3 ln 56-59 | 1-10 |
| A | "REPLENISH IS ON A MISSION TO ELIMINATE WASTE" (REPLENISH) 03 June 2015 (03.06.2015) [online] retrieved from <URL: https://web.archive.org/web/20150603001107/http://www.myreplenish.com/ > pgs 4-5 | 1-10 |
| A | "CAN YOUR BOTTLE DO THIS?" (CLEANPATH) 12 February 2015 (12.02.2015) [online] retrieved from <URL: https://www.youtube.com/watch?v=AZmO3Pw6ka8 > 00:03-16 | 1-10 |
| X/P | US 2015/0360814 A1 (FOSTER) 17 December 2015 (17.12.2015) Figs 1-5; paras [0013-21] | 1-10 |
| <input type="checkbox"/> Further documents are listed in the continuation of Box C. <input type="checkbox"/> | | |
| * Special categories of cited documents: "A" document defining the general state of the art which is not considered to be of particular relevance "E" earlier application or patent but published on or after the international filing date "L" document which may throw doubts on priority claim(s) or which is cited to establish the publication date of another citation or other special reason (as specified) "O" document referring to an oral disclosure, use, exhibition or other means "P" document published prior to the international filing date but later than the priority date claimed "T" later document published after the international filing date or priority date and not in conflict with the application but cited to understand the principle or theory underlying the invention "X" document of particular relevance; the claimed invention cannot be considered novel or cannot be considered to involve an inventive step when the document is taken alone "Y" document of particular relevance; the claimed invention cannot be considered to involve an inventive step when the document is combined with one or more other such documents, such combination being obvious to a person skilled in the art "&" document member of the same patent family | | |
| Date of the actual completion of the international search 19 August 2016 (19.08.2016) | | Date of mailing of the international search report 08 SEP 2016 |
| Name and mailing address of the ISA/US Mail Stop PCT, Attn: ISA/US, Commissioner for Patents P.O. Box 1450, Alexandria, Virginia 22313-1450 Facsimile No. 571-273-8300 | | Authorized officer: Lee W. Young PCT Helpdesk: 571-272-4300 PCT OSP: 571-272-7774 |