



(19) **United States**

(12) **Patent Application Publication**
TSAI et al.

(10) **Pub. No.: US 2009/0212312 A1**

(43) **Pub. Date: Aug. 27, 2009**

(54) **SEMICONDUCTOR LIGHT-EMITTING DEVICE**

Publication Classification

(76) Inventors: **Tzong-Liang TSAI**, Taichung City (TW); **Wei-Kai Wang**, Shengang Township (TW); **Su-Hui Lin**, Taichung City (TW); **Yi-Cun Lu**, Taichung City (TW)

(51) **Int. Cl.**
H01L 33/00 (2006.01)
(52) **U.S. Cl.** **257/98; 257/E33.067**

Correspondence Address:
Muncy, Geissler, Olds & Lowe, PLLC
P.O. BOX 1364
FAIRFAX, VA 22038-1364 (US)

(57) **ABSTRACT**

The invention discloses a semiconductor light-emitting device, which includes a substrate, a first conductive type semiconductor material layer, a second conductive type semiconductor material layer, a light-emitting layer, a first electrode, a second electrode, and a plurality of bump structures. The first conductive type semiconductor material layer is formed on the substrate and has an upper surface which includes a first region and a second region distinct from the first region. The first electrode is formed on the first region. The light-emitting layer and the second conductive type semiconductor material layer are formed on the second region. The bump structures are formed on the upper surface of the first conductive type semiconductor material layer and between the first region and the second region. Each bump structure is made of ITO, SiO₂, SiN, ZnO, polyimide, BCB, SOG, InO, or SnO.

(21) Appl. No.: **12/269,499**

(22) Filed: **Nov. 12, 2008**

Related U.S. Application Data

(63) Continuation of application No. 12/184,933, filed on Aug. 1, 2008.

Foreign Application Priority Data

Feb. 22, 2008 (TW) 097106193

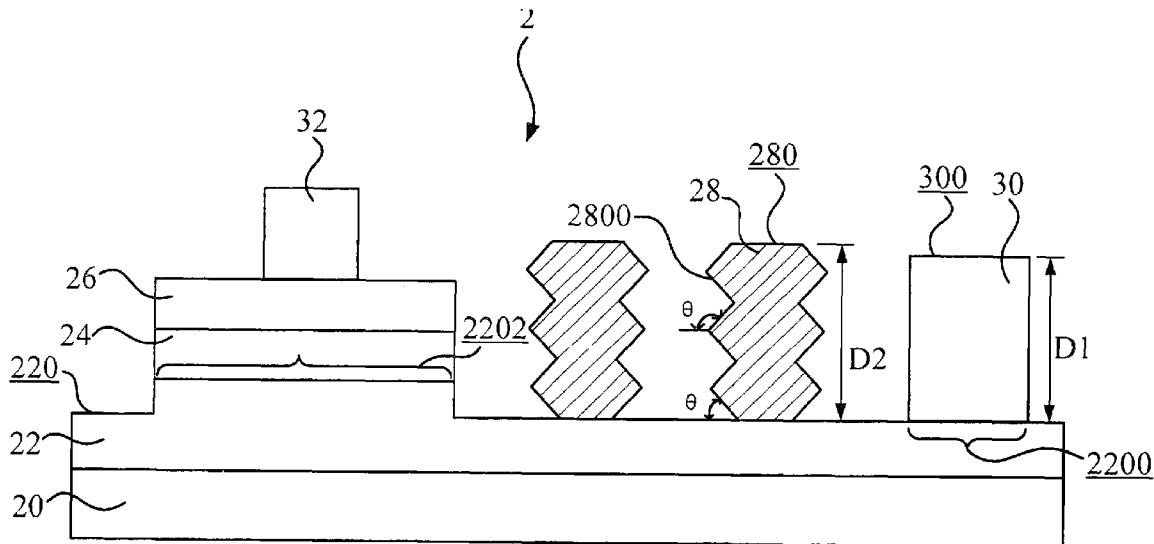

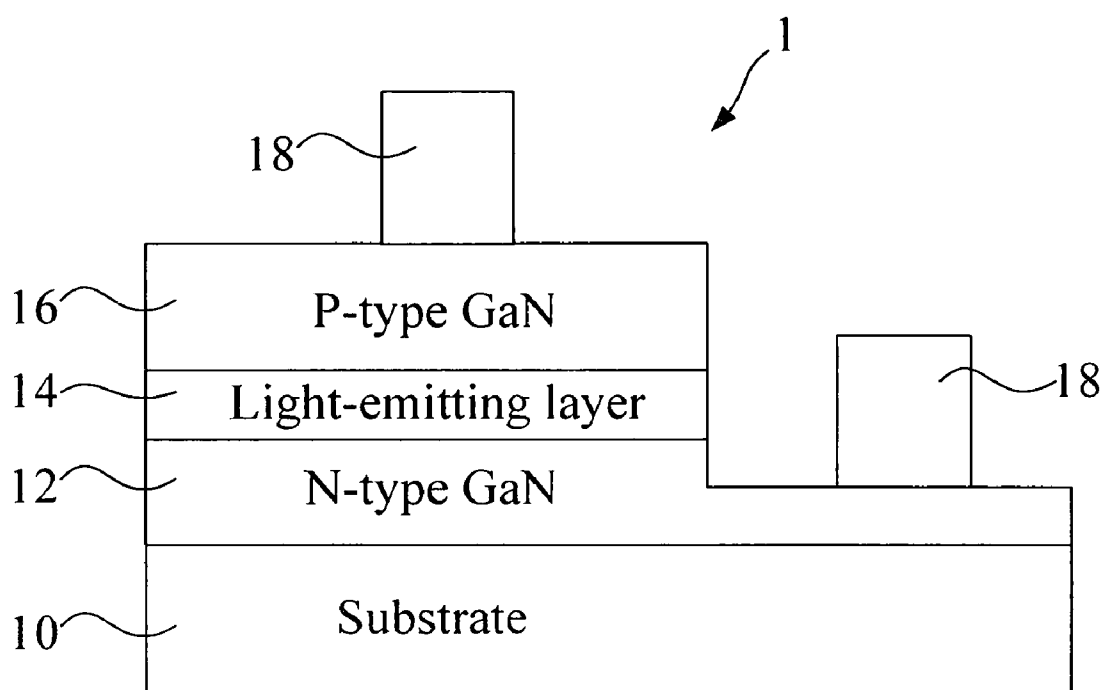

FIG.1 (PRIOR ART)

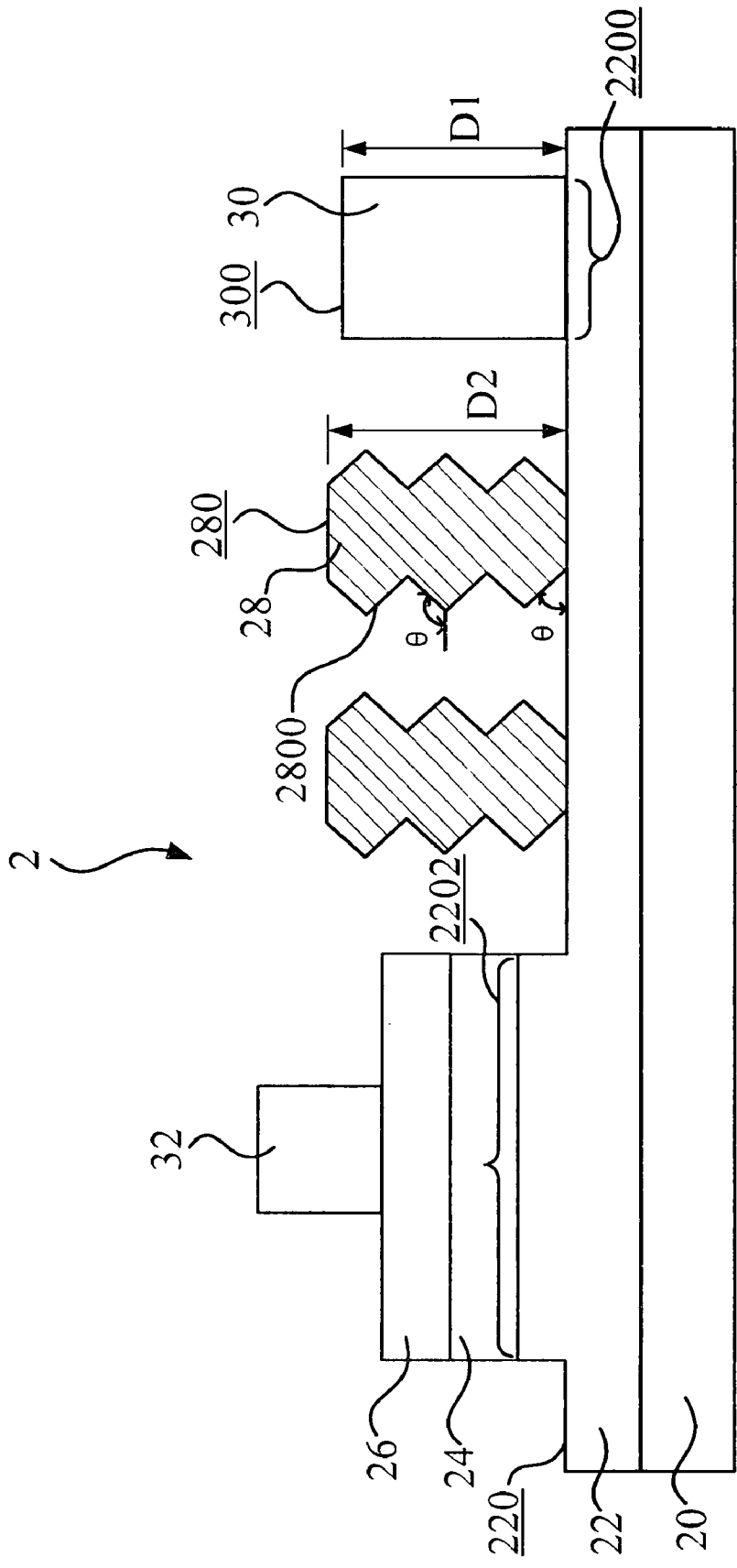

FIG. 2A

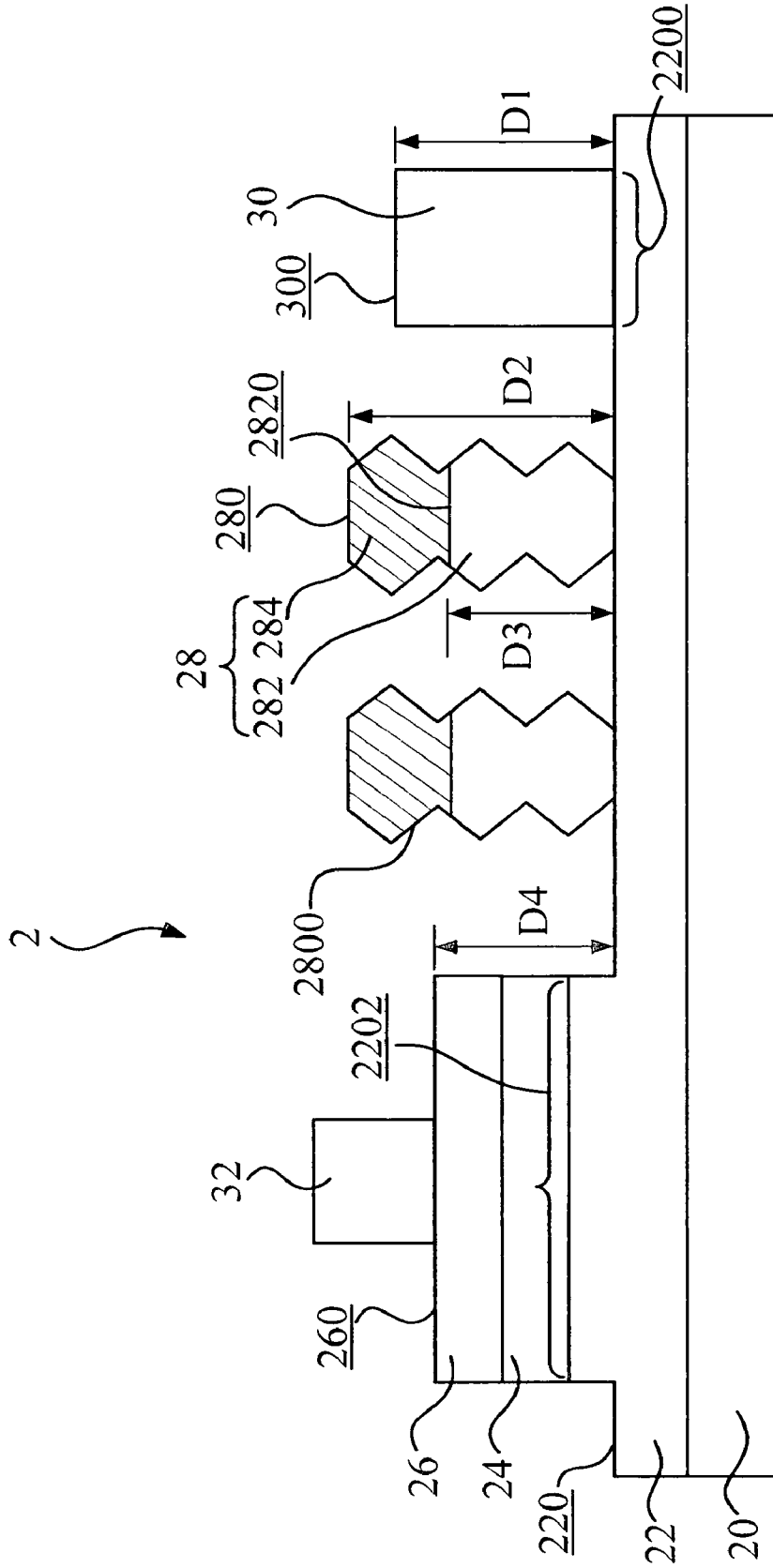

FIG. 2B

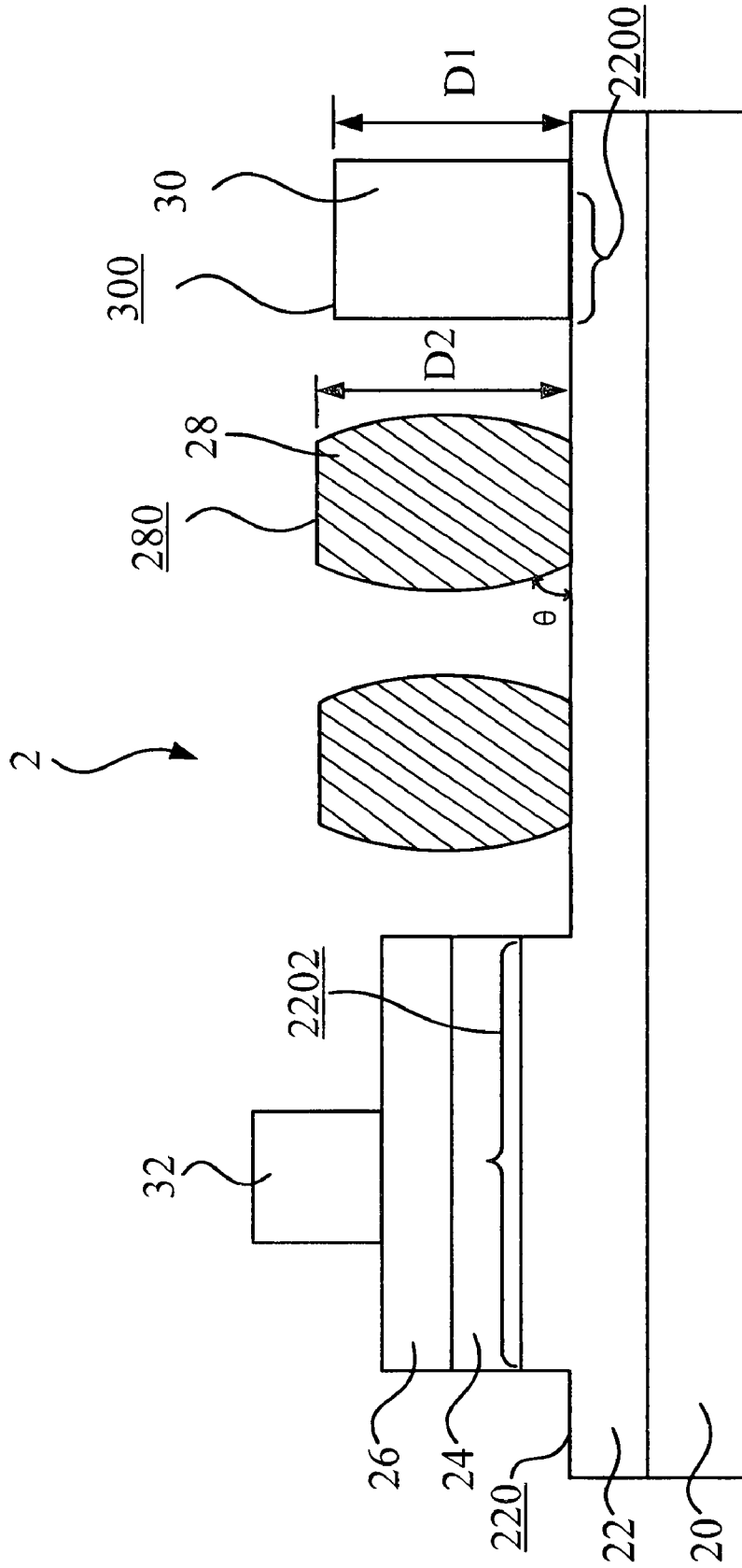

FIG. 3

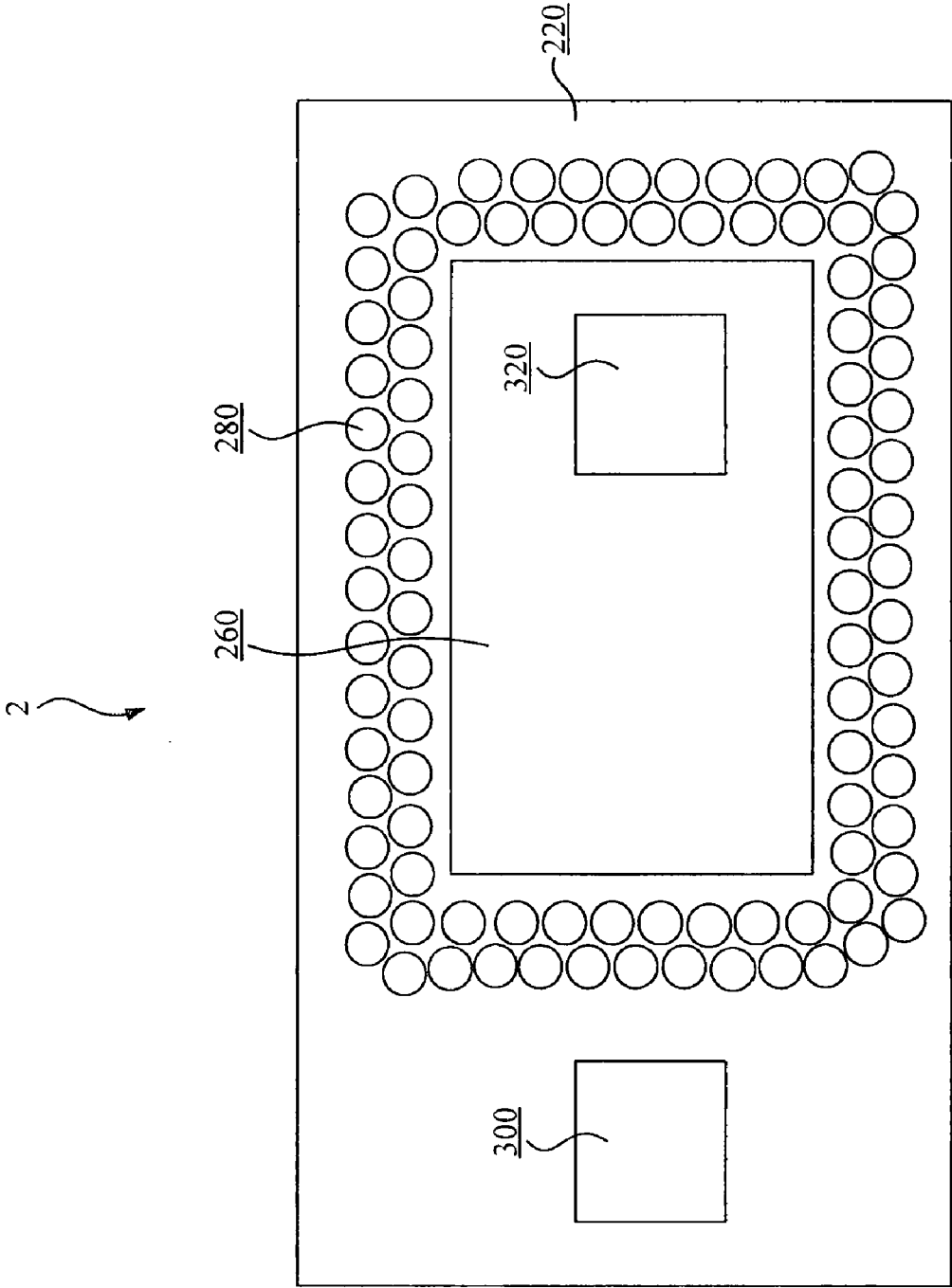

FIG. 4

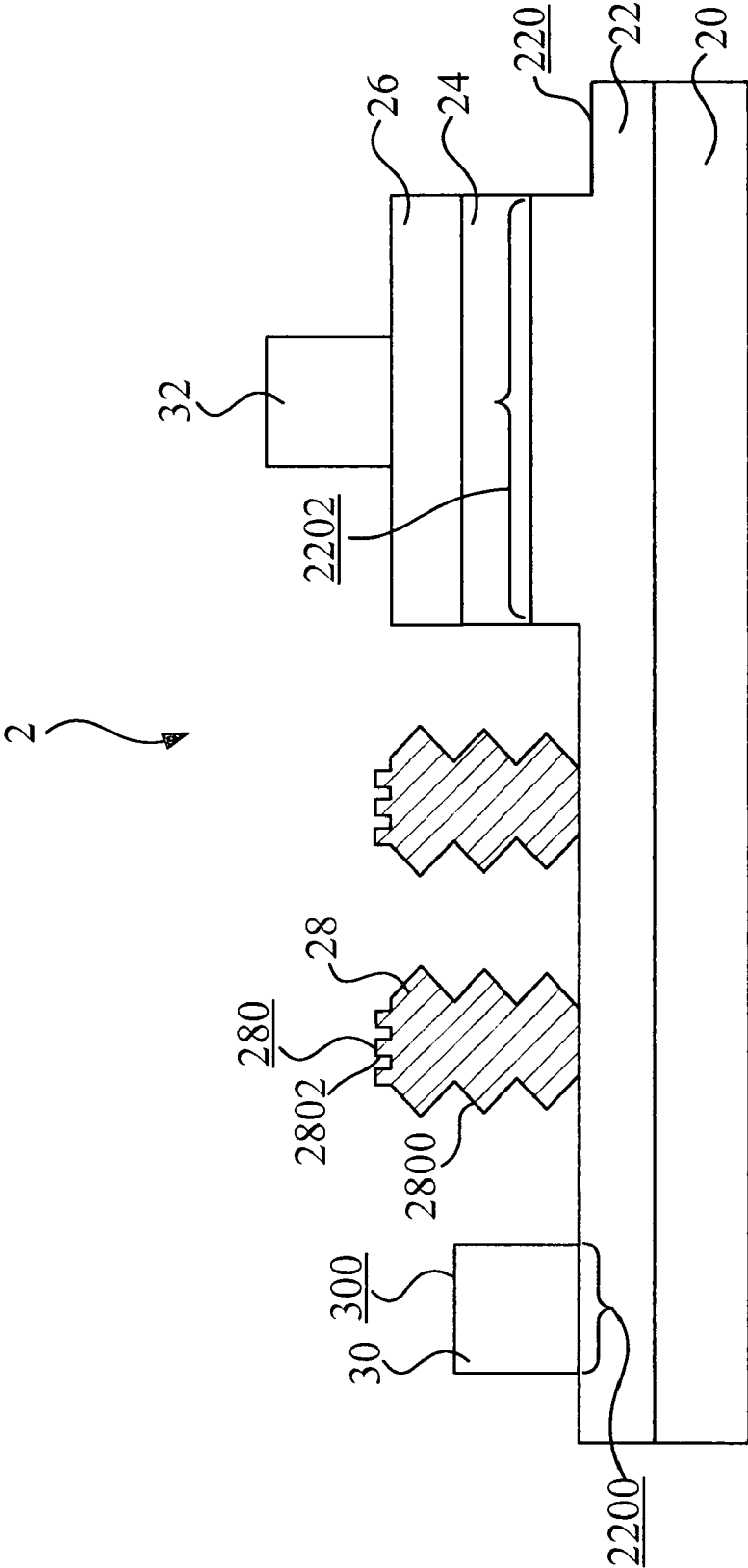

FIG. 5A

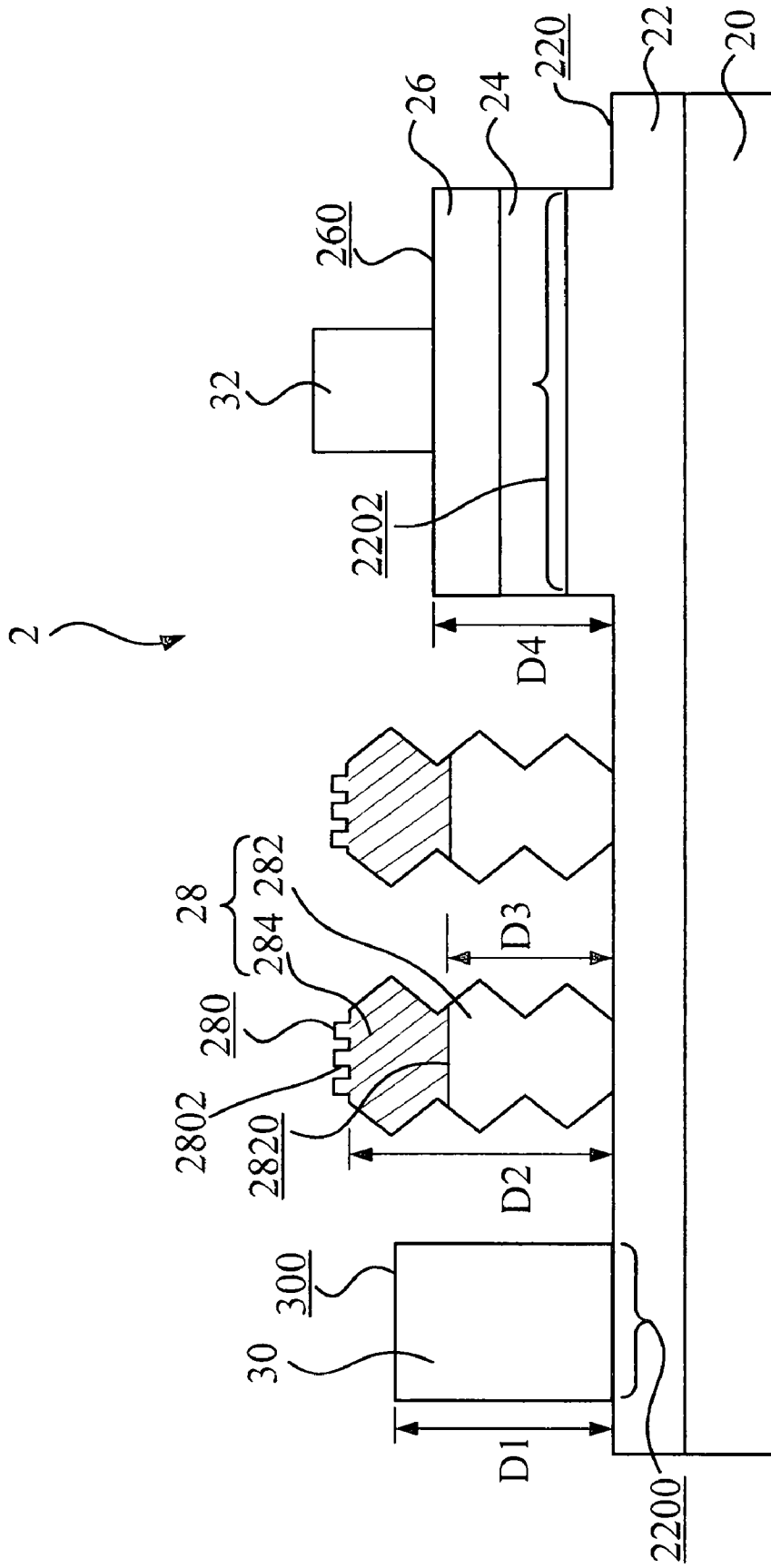

FIG. 5B

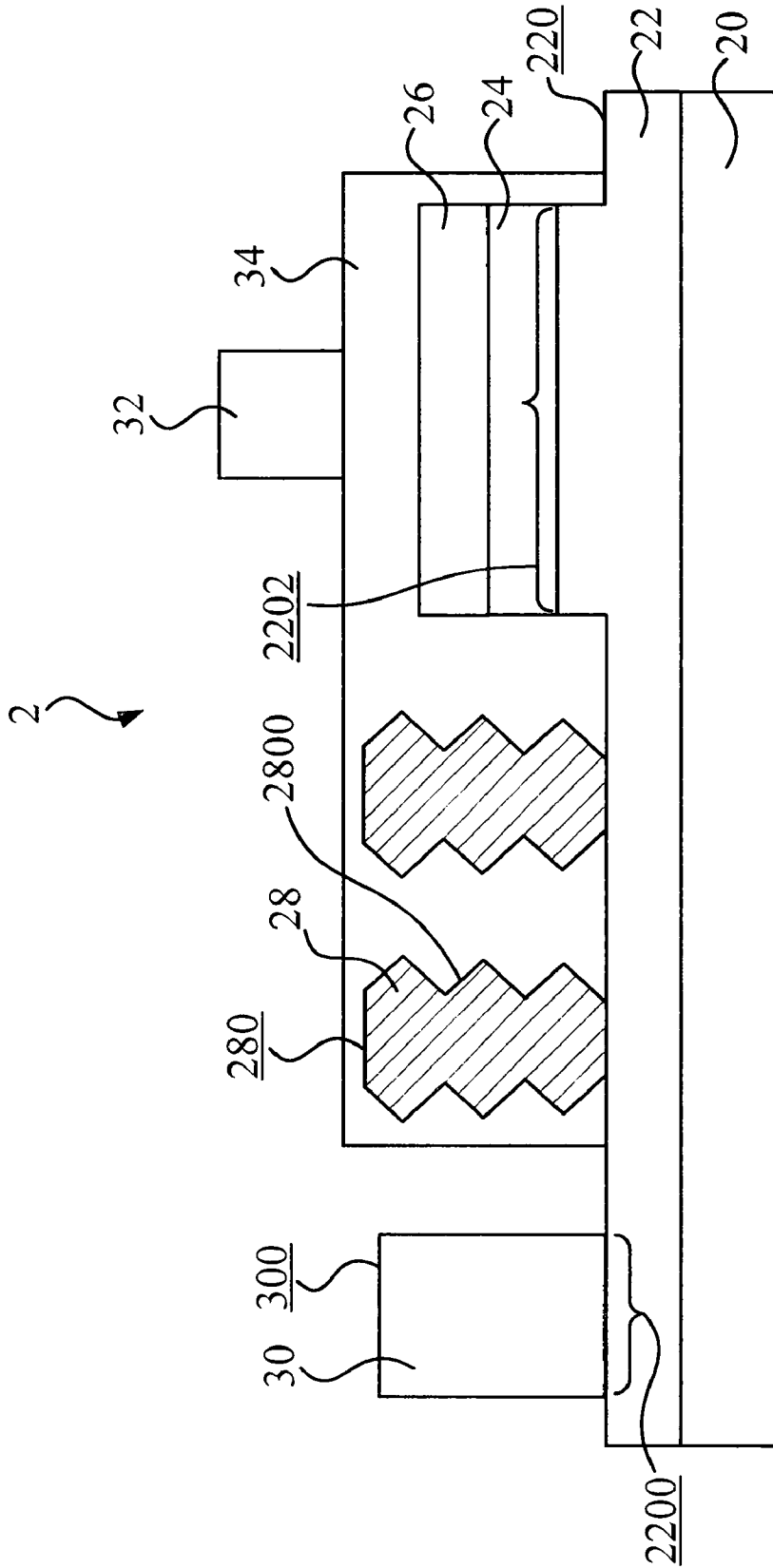

FIG. 6

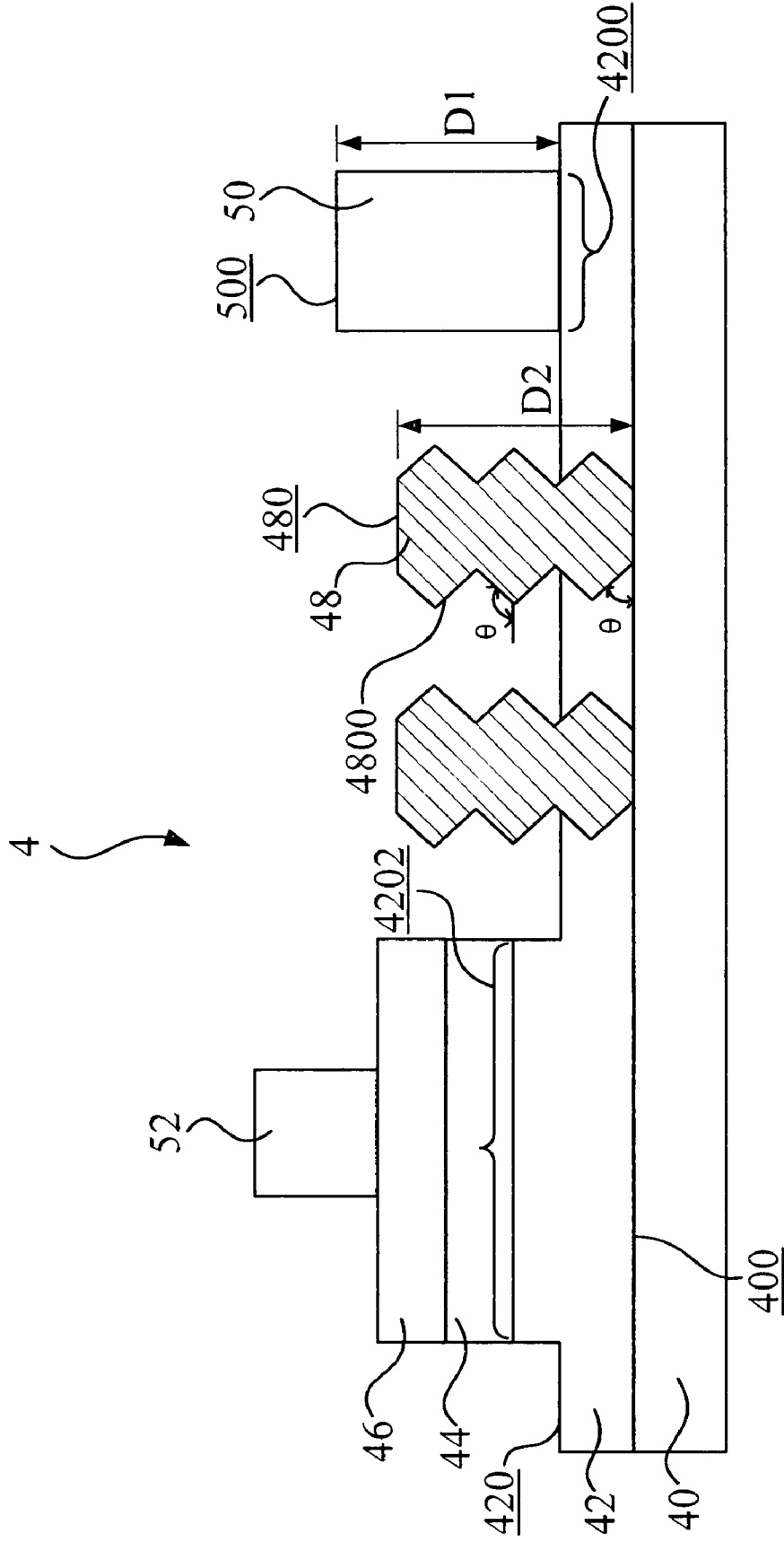

FIG. 7

SEMICONDUCTOR LIGHT-EMITTING DEVICE

CROSS REFERENCE TO RELATED APPLICATIONS

[0001] This application is a Continuation of co-pending application Ser. No. 12/184,933, filed on Aug. 1, 2008, and for which priority is claimed under 35 U.S.C. § 120; the entire contents of which are hereby incorporated by reference.

BACKGROUND OF THE INVENTION

[0002] 1. Field of the Invention

[0003] This invention relates to a semiconductor light-emitting device and, more particularly, to a semiconductor light-emitting device which has high light-extraction efficiency.

[0004] 2. Description of the Prior Art

[0005] In general, semiconductor light-emitting devices (e.g., light-emitting diodes) have been widely used in many application fields, such as key switch systems, back light modules of cell phones, vehicle lighting systems, decorative illuminations, and remote-controlled devices. In order to ensure higher functional reliability and lower energy consumption of semiconductor light-emitting devices, the external quantum efficiency of the semiconductor light-emitting device needs to be well dominated.

[0006] In theory, the external quantum efficiency of the semiconductor light-emitting device relates to its internal quantum efficiency and its light-extraction efficiency. And, the external quantum efficiency is determined by properties and quality of material; the light-extraction efficiency refers to the radiation ratio of the radiation emitted from the internal part of device to air or to the encapsulation material (i.e. epoxy resin). Moreover, the light-extraction efficiency is determined by the consumption that is generated while the irradiation is emitted out of the device. One of the reasons of the consumption is that the semiconductor material of the surface layer formed on the device has high refraction coefficient, which forms total reflection on the surface of the material and then makes light unable to be emitted outward. Accordingly, if the light-extraction efficiency rises, the external quantum efficiency of the semiconductor light-emitting device raise as well.

[0007] Please refer to FIG. 1. FIG. 1 is a schematic diagram illustrating a light-emitting diode 1 of prior arts. As shown in FIG. 1, the light-emitting diode 1 comprises a substrate 10, N-type GaN 12, P-type GaN 16, a light-emitting region 14 and electrodes 18. In order to electrically connect the P-type GaN 16 and the N-type GaN 12 to operate the light-emitting diode 1, one of the electrodes 18 is formed on the P-type GaN 16 and another electrode 18 is formed on the N-type GaN 12. Before forming the another electrode 18, the light-emitting diode 1 needs to partially etch the P-type GaN 16, the light-emitting region 14, and the N-type GaN 12 by etching processes. Then, another electrode 18 is formed on the exposure part of the N-type GaN 12. However, because the light-emitting region 14 is partially etched, not only the emitting area of the light-emitting diode 1 reduces, but also the light-emitting efficiency decreases, as shown in FIG. 1.

[0008] Although various kinds of light-emitting diodes are disclosed nowadays, how to increase the light-extraction efficiency of light-emitting diodes and how to enable the light-emitting diode to emit wide and uniform light are always

popular. Accordingly, the scope of the invention is to provide a semiconductor light-emitting device to solve the above-mentioned problems.

SUMMARY OF THE INVENTION

[0009] A scope of the invention is to provide a semiconductor light-emitting device. The semiconductor light-emitting device has high light-extraction efficiency and is capable of emitting a wide and uniform light.

[0010] According to an embodiment of the invention, the semiconductor light-emitting device includes a substrate, a first conductive type semiconductor material layer, a second conductive type semiconductor material layer, a light-emitting layer, a first electrode, a second electrode, and a plurality of bump structures.

[0011] The first conductive type semiconductor material layer is formed on the substrate. The first conductive type semiconductor material layer has an upper surface, and the upper surface includes a first region and a second region which is distinct from the first region. The first electrode is formed on the first region, and the light-emitting layer is formed on the second region. The second conductive type semiconductor material layer is formed on the light-emitting layer. The second electrode is formed on the second conductive type semiconductor material layer. The plurality of bump structures are formed on the upper surface of the first conductive type semiconductor material layer and between the first region and the second region

[0012] Furthermore, each of the plurality of bump structures is made of the material whose refraction index is larger than one, and the material refers to ITO, SiO₂, SiN, ZnO, polyimide, BCB, SOG, InO, or SnO.

[0013] According to another embodiment of the invention, each of the plurality of bump structures is formed by a first structure layer and a second structure layer. The first structure layer is formed on the upper surface of the first conductive type semiconductor material layer. The second structure layer is formed on the first structure layer and is made of the material whose refraction index is larger than 1. The material refers to ITO, SiO₂, SiN, ZnO, polyimide, BCB, SOG, InO, or SnO.

[0014] The advantage and spirit of the invention may be understood by the following recitations together with the appended drawings.

BRIEF DESCRIPTION OF THE APPENDED DRAWINGS

[0015] FIG. 1 is a schematic diagram illustrating a light-emitting diode of prior arts.

[0016] FIG. 2A is a cross-sectional view illustrating a semiconductor light-emitting device according to an embodiment of the invention.

[0017] FIG. 2B is a cross-sectional view illustrating another semiconductor light-emitting device according to an embodiment of the invention.

[0018] FIG. 3 is a schematic diagram illustrating that the sidewall of each bump structure has a curved contour.

[0019] FIG. 4 is a top view illustrating the semiconductor light-emitting device according to the invention.

[0020] FIG. 5A is a cross-sectional view illustrating at least one recess which is further formed on the top surface of the bump structure in FIG. 2A.

[0021] FIG. 5B is a cross-sectional view illustrating at least one recess which is further formed on the top surface of the bump structure in FIG. 2B.

[0022] FIG. 6 is a cross-sectional view illustrating the semiconductor light-emitting device which further includes a transparent conductive layer according to an embodiment of the invention.

[0023] FIG. 7 is a cross-sectional view illustrating a semiconductor light-emitting device 4 according to another embodiment of the invention.

DETAILED DESCRIPTION OF THE INVENTION

[0024] Please refer to FIG. 2A. FIG. 2A is a cross-sectional view illustrating a semiconductor light-emitting device 2 according to an embodiment of the invention.

[0025] As shown in FIG. 2A, the semiconductor light-emitting device 2 includes a substrate 20, a first conductive type semiconductor material layer 22, a light-emitting layer 24, a second conductive type semiconductor material layer 26, a first electrode 30, a second electrode 32, and a plurality of bump structures 28.

[0026] In a practical application, the substrate 20 can be, but not limited to, glass, silicon, Ge, GaN, GaAs, GaP, AlN, sapphire, spinel, Al₂O₃, SiC, ZnO, MgO, LiAlO₂, GaLiO₂, or MgAlO₄.

[0027] According to an embodiment, the first conductive type semiconductor material layer 22 and the second conductive type semiconductor material layer 26 are made of Group III-V compound semiconductor material.

[0028] The Group III element of the Group III-V compound semiconductor material can be such as Al, Ga, or In. The Group V element of the Group III-V compound semiconductor material can be N, P, or As. In the embodiment, the first conductive type semiconductor material layer 22 and the second conductive type semiconductor material layer 26 can be made of GaN.

[0029] The first conductive type semiconductor material layer 22 is formed on the substrate 20, and the first conductive type can be N type. In other words, the first conductive type semiconductor material layer 22 is a N type GaN contact layer. The first conductive type semiconductor material layer 22 has an upper surface 220, and the upper surface 220 includes a first region 2200 and a second region 2202 which is distinct from the first region 2200. The first electrode 30 is formed on the first region 2200, and the light-emitting layer 24 is formed on the second region 2202. The first electrode 30 is a N type electrode.

[0030] The second conductive type semiconductor material layer 26 is formed on the light-emitting layer 24. The second conductive semiconductor material layer 26 which corresponds to the first conductive semiconductor material layer 22 is a P type GaN contact layer. The second electrode 32 can be formed on the second conductive type semiconductor material layer 26, and the second electrode is a P type electrode. Moreover, a transparent conductive layer (not shown in the figures) can be further formed on the second conductive type semiconductor material layer 26.

[0031] As shown in FIG. 2A, the plurality of bump structures 28 are formed on the upper surface 220 of the first conductive type semiconductor material layer 22 and between the first region 2200 and the second region 2202. In a practical application, each bump structure 28 can be in a form of a column, an ellipse, or a polygon, etc., according to the top view.

[0032] According to the invention, each bump structure 28 can be made of a specific material whose refraction index is larger than 1. The specific material can be, but not limited to, ITO, SiO₂, SiN, ZnO, polyimide, BCB, SOG, InO, SnO, a Group III-V compound semiconductor material, or a Group II-VI compound semiconductor material. The Group III element and the Group V element of the Group III-V compound semiconductor material are the same as the above-mentioned description. The Group II element of the Group II-VI compound semiconductor material can be Be, Mg, Ga, or Sr. The Group VI element of the Group II-VI compound semiconductor material can be O, S, Se, or Te. In an embodiment, each bump structure 28 also can be formed by the insulation material whose refraction index is larger than 1.

[0033] Owing to the difference between the refraction index of air and that of the specific material, the light-extraction efficiency of the semiconductor light-emitting device 2 can be effectively prompted. Because the refraction index of the specific material is larger than 1 (e.g., the refraction index of air is 1), the side light emitted by the semiconductor light-emitting device 2 can be refracted upward or downward via the specific material and prevent from being absorbed by the first electrode 30 to increase the light-extraction efficiency of the semiconductor light-emitting device 2.

[0034] In order to prevent the light which is emitted from the light-emitting layer 24 from being absorbed by the first electrode 30, the height of each bump structure 28 can be substantially equal to or higher than that of the first electrode 30. As shown in FIG. 2A, if the upper surface 220 of the first conductive type semiconductor material layer 22 is regarded as a reference plane, the height of the top surface 300 of each first electrode 30 is D1, the height of the top surface 280 of each bump surface 28 is D2, and D2 can be substantially equal to or larger than D1 to prevent the light from emitting to the first electrode 30.

[0035] Please refer to the FIG. 2B. FIG. 2B is schematic diagram illustrating a cross-sectional view of the semiconductor light-emitting device 2 according to another embodiment of the invention. In the embodiment, each bump structure 28 can comprise a first structure layer 282 and a second structure layer 284. In a practical application, the first structure layer 282 can be composed of the first conductive type semiconductor material layer 22, the second conductive type semiconductor material layer 26 and the light-emitting layer 24. It is notable that in order to prevent the light which is emitted from the semiconductor light-emitting device 2 from being absorbed, the light-emitting layer 284 of each bump structure 28 can be removed. Or, the first structure layer 282 can be totally composed of the first conductive type semiconductor material layer 22. The second structure layer 284 is formed on the first structure 282 and is made of a specific material whose refraction index is larger than 1. And, the specific material can be, but not limited to, ITO, SiO₂, ZnO, polyimide, BCB, SOG, InO or SnO.

[0036] In one preferred embodiment, it is assumed that the upper surface 220 of the first conductive type semiconductor material layer 22 is regarded as a reference plane. Then, the height of the top surface 300 of first electrode 30 is D1, the height of the top surface 280 of each bump structure 28 is D2, and D2 is substantially equal to or larger than D1 to prevent the light which is emitted by the light-emitting layer 24 from being absorbed by the first electrode 30. Thus, the light which is emitted by the light-emitting layer 24 can prevent from being absorbed by the first electrode 30 to increase the light-

extraction efficiency; moreover, the height of the top surface **2820** of the first structure layer **282** will be **D3**, and the height of the top surface **260** of the second conductive type semiconductor material layer **26** will be **D4**, wherein, **D4** is substantially equal to or larger than **D3**.

[0037] Please refer to the FIG. 2A and FIG. 2B. In an embodiment, at least one recess **2800** is formed in the sidewall of each bump structure **28**. As shown in the FIG. 2A and FIG. 2B, the sidewall of each bump structure **28** is incised, so that the sidewall forms a plurality of recess **2800**. That is to say, the sidewall of each bump structure **28** has a roughened surface morphology. Or in another embodiment, the sidewall of each bump structure **28** substantially has a curved contour, as shown in FIG. 3.

[0038] Assume that the sidewall of each bump structure **28** has a straight contour, and the included angle between the sidewall and the upper surface **220** of the first conductive type semiconductor material layer **22** equals to 90 degrees, the light which is emitted from the light-emitting layer **24** will be constrained to be reflected between the bump structure **28** and the main body of the semiconductor light-emitting device **2**. However, because each sidewall of the bump structure **28** has a roughened surface morphology or a curved contour, the included angle θ between a part of the sidewall and the upper surface **220** of the first conductive type semiconductor material layer **22** may be larger than or smaller than 90 degrees, as shown in FIG. 2A, FIG. 2B, and FIG. 3. Thus, the light which is emitted from the light-emitting layer **24**, especially the side light, can be reflected to change the direction by the sidewall of the bump structure **28** after being emitted to the bump structure **28**. And, the probability of emitting the light out of the observation side of the semiconductor light-emitting device **2** thus increases.

[0039] In additional, assume that the observation side of the semiconductor light-emitting device **2** is upward, the light which is emitted from the light-emitting layer toward the bottom of the semiconductor light-emitting device **2** will be guided to emit out the observation side by the plurality of bump structures **28** when the light is reflected to be emitted toward the plurality of bump structures **28**. Besides, if the plurality of bump structures **28** is distributed uniformly on the upper surface **220** of the first conductive semiconductor material layer **22**, the semiconductor light-emitting device **2** can produce the light that is wider and more uniform.

[0040] Please refer to FIG. 4. FIG. 4 is a top view illustrating the semiconductor light-emitting device **2** according to the invention. In a practical application, the plurality of bump structures **28** need to be surrounded by the light-emitting layer **24** (not shown in FIG. 4) to guide the light emitted from the light-emitting layer **24** toward the observation side of the semiconductor light-emitting device **2**. In a preferred embodiment, the plurality of bump structures **28** can be arranged to be two substantially concentric circular patterns, and the circular patterns are staggered to ensure that the plurality of bump structures **28** guide the light emitted from the light-emitting layer **24** toward the observation side of the semiconductor light-emitting device **2**, as the FIG. 4 shown. Furthermore, the plurality of bump structures **28** also can be fully disposed on the upper surface **220** of the first conductive type semiconductor material layer **22** to ensure that the light-extraction efficiency of the semiconductor light-emitting device **2** can be increased.

[0041] Please refer to the FIG. 5A and FIG. 5B. FIG. 5A is a cross-sectional view illustrating at least one recess **2802**

which is further formed on the top surface **280** of the bump structure **28** in FIG. 2A. FIG. 5B is a cross-sectional view illustrating at least one recess **2802** which is further formed on the top surface **280** of the bump structure **28** in FIG. 2B. In other words, the top surface **280** of the bump structure **28** can also has a roughened surface morphology besides the sidewall. In a practical application, the top surface **280** of the bump structure **28** can also has a curved contour. And, whatever the top surface **280** of the bump structure **28** has a roughened surface morphology or a curved contour, and it can increase the light-extraction efficiency.

[0042] Please refer to FIG. 6. FIG. 6 is a cross-sectional view illustrating the semiconductor light-emitting device **2** which further includes a transparent conductive layer **34** according to one embodiment of the invention. As shown in FIG. 6, the transparent conductive layer **34** is formed on the upper surface **220** of the first conductive type semiconductor material layer **22** and enwraps the second conductive type semiconductor material layer **26**, the light-emitting layer **24**, and the plurality of bump structures **28**. In the embodiment, the second electrode **32** can be formed on the transparent conductive layer **34** after the transparent conductive layer **34** is formed. In a practical application, the transparent conductive layer **34** can be made of, but not limited to, a thin metal layer, a meshed conductive layer, ITO, or ZnO.

[0043] Please refer to FIG. 7. FIG. 7 is a cross-sectional view illustrating a semiconductor light-emitting device **4** according to another embodiment of the invention. As shown in FIG. 7, the semiconductor light-emitting device **4** includes a substrate **40**, a plurality of bump structures **48**, a first conductive type semiconductor material layer **42**, a light-emitting layer **44**, a second conductive type semiconductor material layer **46**, a first electrode **50**, and a second electrode **52**. The substrate **40** has a first upper surface **400**. The plurality of bump structures **48** are formed on the first upper surface **400** of the substrate **40**. Each of the plurality of bump structures **48** is made of a material whose refractive index is larger than 1. The first conductive type semiconductor material layer **42** covers the first upper surface **400** of the substrate **40**, so as to make the plurality of bump structures **48** to expose out of the first conductive type semiconductor material layer **42**. The first conductive type semiconductor material layer **42** has a second upper surface **420**, and the second upper surface **420** comprises a first region **4200** and a second region **4202** distinct from the first region **4200**. The light-emitting layer **44** is formed on the second region **4202**. The first electrode **50** is formed on the first region **4200**, so that the plurality of bump structures **48** are between the light-emitting layer **44** and the first electrode **50**. The second conductive type semiconductor material layer **46** is formed on the light-emitting layer **44**. The second electrode **52** is formed on the second conductive type semiconductor material layer **46**.

[0044] Compared with prior arts, the semiconductor light-emitting device according to the invention can guide the light emitted from the semiconductor light-emitting device toward the observation side by the plurality of bump structures, so as to increase the light-extraction efficiency of the semiconductor light-emitting device and generate the light that is wider and more uniform. Particularly, the bump structure according to the invention can has a roughened surface morphology or a curved contour, thus the light-extraction efficiency can be prompted. Additionally, owing to high light-extraction efficiency, the semiconductor light-emitting device of the invention can be applied to photo-pump.

[0045] With the example and explanations above, the features and spirits of the invention will be hopefully well described. Those skilled in the art will readily observe that numerous modifications and alterations of the device may be made while retaining the teaching of the invention. Accordingly, the above disclosure should be construed as limited only by the metes and bounds of the appended claims.

What is claimed is:

1. A semiconductor light-emitting device, comprising:
 - a substrate;
 - a first conductive type semiconductor material layer, the first conductive type semiconductor material layer being formed on the substrate and having an upper surface, and the upper surface comprising a first region and a second region distinct from the first region;
 - a first electrode being formed on the first region;
 - a light-emitting layer being formed on the second region;
 - a second conductive type semiconductor material layer being formed on the light-emitting layer;
 - a second electrode being formed on the second conductive type semiconductor material layer; and
 - a plurality of bump structures being formed on the upper surface of the first conductive type semiconductor material layer and between the first region and the second region, wherein each of the plurality of bump structures is made of a material whose refractive index is larger than 1, and the material is one selected from the group consisting of ITO, SiO₂, SiN, ZnO, polyimide, BCB, SOG, InO, SnO, a Group III-V compound semiconductor material, and a Group II-VI compound semiconductor material.
2. The semiconductor light-emitting device of claim 1, wherein an included angle between a part of the sidewall of each bump structure and the upper surface of the first conductive type semiconductor material layer is larger than or smaller than 90 degrees.
3. The semiconductor light-emitting device of claim 1, wherein the height of a first top surface of the first electrode is substantially equal to or smaller than that of a second top surface of each bump structure.
4. The semiconductor light-emitting device of claim 1, wherein the material is an insulating material.
5. The semiconductor light-emitting device of claim 1, further comprising a transparent conductive layer, the transparent conductive layer being formed on the upper surface of the first conductive type semiconductor material layer and enveloping the second conductive type semiconductor material layer, the light-emitting layer, and the plurality of bump structures.
6. The semiconductor light-emitting device of claim 1, wherein at least one recess is formed on the sidewall of each bump structure or the sidewall of each bump structure has a curved contour.
7. The semiconductor light-emitting device of claim 6, wherein the at least one recess is further formed on the top surface of each bump structure or the top surface of each bump structure further has a curved contour.
8. The semiconductor light-emitting device of claim 1, wherein the first conductive type is N type, and the second conductive type is P type.
9. The semiconductor light-emitting device of claim 1, wherein the substrate is formed by one selected from the

group consisting of glass, silicon, GaN, GaAs, GaP, AlN, sapphire, spinel, Al₂O₃, SiC, ZnO, MgO, LiAlO₂, LiGaO₂ and MgAlO₄.

10. The semiconductor light-emitting device of claim 1, further comprising a transparent conductive layer, the transparent conductive layer being formed on the second conductive type semiconductor material layer.

11. A semiconductor light-emitting device, comprising:

- a substrate;
- a first conductive type material semiconductor layer, the first conductive type semiconductor material layer being formed on the substrate and having an upper surface, and the upper surface comprising a first region and a second region distinct from the first region;
- a first electrode being formed on the first region;
- a light-emitting layer being formed on the second region;
- a second conductive type semiconductor material layer being formed on the light-emitting layer;
- a second electrode being formed on the second conductive type semiconductor material layer; and
- a plurality of bump structures being formed on the upper surface of the first conductive type semiconductor material layer and between the first region and second region, wherein each of the bump structures is formed by a first structure layer and a second structure layer, the first structure layer is formed on the upper surface of the first conductive type semiconductor material layer, the second structure layer is formed on the first structure layer and is made of a material whose refractive index is larger than 1, and the material is one selected from the group consisting of ITO, SiO₂, SiN, ZnO, polyimide, BCB, SOG, InO, SnO, a Group III-V compound semiconductor material, and a Group II-VI compound semiconductor material.

12. The semiconductor light-emitting device of claim 11, wherein the height of a first top surface of the first electrode is substantially equal to or smaller than that of a second top surface of each bump structure.

13. The semiconductor light-emitting device of claim 12, wherein the height of a third top surface of the first structure layer is substantially equal to or smaller than that of a fourth top surface of the second conductive type semiconductor material layer.

14. The semiconductor light-emitting device of claim 11, wherein an included angle between a part of the sidewall of each bump structure and the upper surface of the first conductive type semiconductor material layer is larger than or smaller than 90 degrees.

15. The semiconductor light-emitting device of claim 11, further comprising a transparent conductive layer, the transparent conductive layer being formed on the upper surface of the first conductive type semiconductor material layer and enveloping the second conductive type semiconductor material layer, the light-emitting layer, and the plurality of bump structures.

16. The semiconductor light-emitting device of claim 11, wherein at least one recess is further formed on the sidewall of each bump structure or the sidewall of each bump structure has a curved contour.

17. The semiconductor light-emitting device of claim 16 wherein the at least one recess is further formed on the top surface of each bump structure or the top surface of each bump structure further has a curved contour.

18. The semiconductor light-emitting device of claim **11**, wherein the first conductive type is N type, and the second conductive type is P type.

19. The semiconductor light-emitting device of claim **11**, wherein the substrate is formed by one selected from the group consisting of glass, silicon, GaN, GaAs, GaP, AlN, sapphire, spinel, Al₂O₃, SiC, ZnO, MgO, LiAlO₂, LiGaO₂ and MgAlO₄.

20. The semiconductor light-emitting device of claim **11**, further comprising a transparent conductive layer, the transparent conductive layer being formed on the second conductive type semiconductor material layer.

21. A semiconductor light-emitting device, comprising:

a substrate having a first upper surface;

a plurality of bump structures being formed on the first upper surface of the substrate, wherein each of the plurality of bump structures is made of a material whose refractive index is larger than 1;

a first conductive type semiconductor material layer, the first conductive type semiconductor material layer covering the first upper surface of the substrate, so as to make the plurality of bump structures to expose out of the first conductive type semiconductor material layer,

wherein the first conductive type semiconductor material layer has a second upper surface, and the second upper surface comprises a first region and a second region distinct from the first region;

a light-emitting layer being formed on the second region; a first electrode being formed on the first region, so that the plurality of bump structures are between the light-emitting layer and the first electrode;

a second conductive type semiconductor material layer being formed on the light-emitting layer; and a second electrode being formed on the second conductive type semiconductor material layer.

22. The semiconductor light-emitting device of claim **21**, wherein the material is one selected from the group consisting of ITO, SiO₂, SiN, ZnO, polyimide, BCB, SOG, InO, SnO, a Group III-V compound semiconductor material, and a Group II-VI compound semiconductor material.

23. The semiconductor light-emitting device of claim **21**, further comprising a transparent conductive layer, the transparent conductive layer being formed on the second conductive type semiconductor material layer.

* * * * *