

Oct. 13, 1925.

1,556,847

H. W. KRANZ

MACHINE FOR SIZING, CUPPING, AND PUNCHING RIMS

Filed May 24, 1920

2 Sheets-Sheet 1

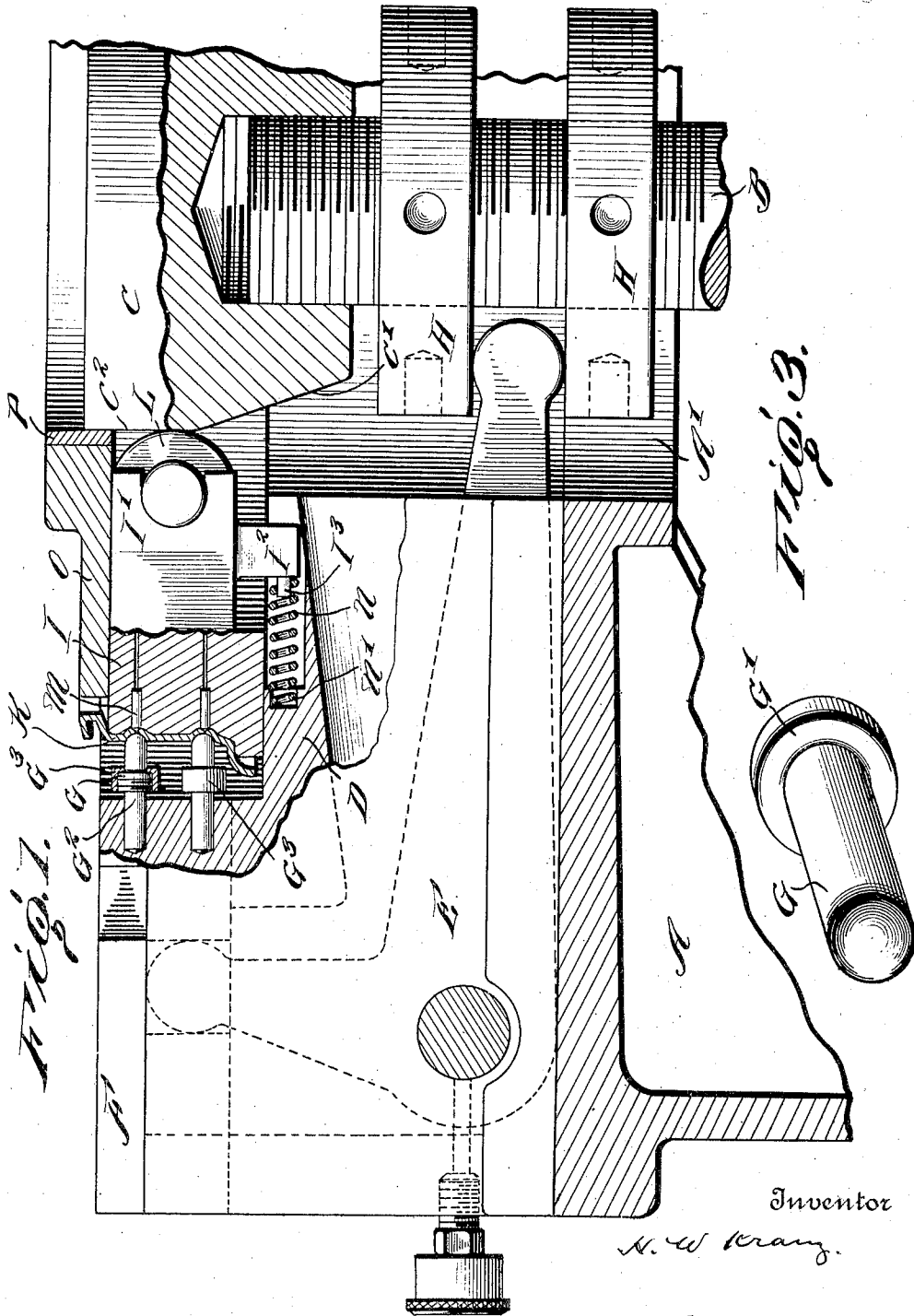

*Fig. 1.*

*Fig. 3.*

Inventor

*H. W. Kranz.*

*By* *Full Smith Brock & Went*

Attorney

Oct. 13, 1925.

1,556,847

H. W. KRANZ

MACHINE FOR SIZING, CUPPING, AND PUNCHING RIMS

Filed May 24, 1920

2 Sheets-Sheet 2

*FIG. 2.*

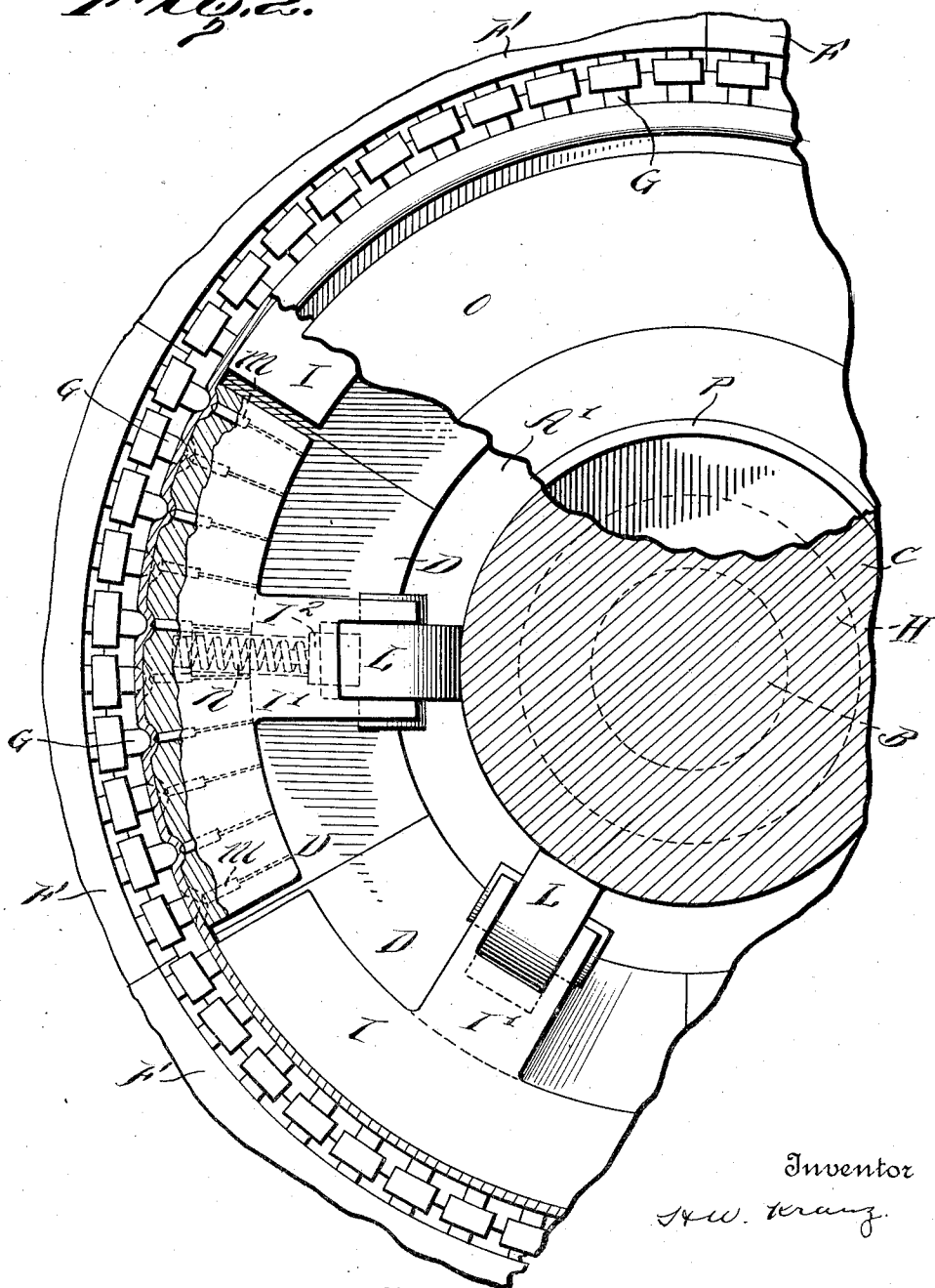

Inventor  
*H. W. Kranz.*

334

*Kull Smith Brock & Co.*  
Attorney

Patented Oct. 13, 1925.

1,556,847

# UNITED STATES PATENT OFFICE.

HARRY W. KRANZ, OF CLEVELAND, OHIO, ASSIGNOR TO THE HYDRAULIC PRESSED STEEL COMPANY, OF CLEVELAND, OHIO, A CORPORATION OF OHIO.

MACHINE FOR SIZING, CUPPING, AND PUNCHING RIMS.

Application filed May 24, 1920. Serial No. 333,765.

*To all whom it may concern:*

Be it known that I, HARRY W. KRANZ, a citizen of the United States, residing at Cleveland, in the county of Cuyahoga and State of Ohio, have invented a certain new and useful Improvement in Machines for Sizing, Cupping, and Punching Rims, of which the following is a full, clear, and exact description, reference being had to the accompanying drawings.

This invention relates to a novel construction of machine for shaping and cupping rims particularly intended for use in wire wheels, and the object of the invention is to provide a simple and efficient apparatus for quickly and accurately sizing the rim, cupping the same to receive the heads of the spoke spindles and simultaneously punching or indenting the reverse side of the cup in order to provide a uniform distribution of metal and prevent splitting or cracking during the cupping operation. With these objects in view the invention consists in the novel features of construction and in the manner of combining or arranging them, all of which will be fully described hereinafter and set forth in the appended claims.

In the drawings forming a part of the specification, Fig. 1 is a view partly in section and partly in elevation disclosing the operative features of a machine embodying my invention; Fig. 2 is a view illustrating partly in section and partly in top plan a portion of the machine embodying my invention; and Fig. 3 is an enlarged detail view of one of the cupping punches.

In the practical embodiment of my invention, I employ a suitable base A having a central circular opening A' and working through this central circular opening A' is a shaft B carrying a plunger C at the upper end thereof, said plunger being tapered downwardly as shown at C' and cylindrical at the extreme upper end, as shown at C<sup>2</sup>. This plunger is threaded upon the upper end of the shaft B and moves therewith but can be removed therethrough and a different plunger substituted when desired. Mounted upon the base A are a plurality of segments D each segment having pivoted therein an elbow lever E the upper end of which operates upon a sector F carrying a plurality of cupping punches G and the lower end of this bell crank lever works between and is operated by the collars H adjustably

mounted upon the shaft B so as to increase or decrease the movement of the bell crank lever as desired and it will be understood that when the shaft B is moved downwardly the lower end of the bell crank lever will be carried downwardly throwing the upper end inwardly carrying with it the punch sector and there being a plurality of sectors each operated by its respective bell crank lever which in turn are all operated at the same time from the plunger shaft, all of the cupping sectors will move inwardly the proper distance at one and the same time. I indicate the sizing and punching sectors which when placed together provide a complete ring upon which the rim K can be mounted and the exterior of these sectors is shaped to conform to the shape of said rim.

Each sector I has an inwardly extending arm I' in which is mounted a roller L which is adapted to be engaged by the tapered or wedge-shaped plunger C, said plunger serving to force the sectors I radially outwardly as the plunger descends thereby stretching and sizing the rim placed thereon, and inasmuch as the bell crank levers are operatively connected with the plunger, the cupping sectors will be forced radially inwardly at the same time that the sizing and punching sectors are forced radially outwardly and in this manner the series of cupping punches are brought into contact with the rim and a series of cup-like depressions produced in said rim and in order to prevent the breaking or cracking of said cup-like depressions during this operation, I provide a punch M in the sector I for each cup, this punch being so arranged and of such size that when the cupping operation is taking place a counter depression is being made upon the inner or convex side of said cup. Each arm I' is also provided with a depending lug I<sup>2</sup> carrying an outwardly projecting pin I<sup>3</sup> and a coiled spring N is fixed upon this pin and at its opposite end seats in a recess N' produced in the face of the segment D.

The sizing and punching sectors slide upon the segments as shown in Fig. 1 and this spring will serve to move the sectors inwardly as the plunger is raised and the bell crank levers move the cupping sectors outwardly.

A top ring O is arranged upon the punch sectors and a guide ring P is arranged cen-

trally therein and in which the cylindrical portion of the plunger works as most clearly shown in Fig. 1. The cupping punches G are formed with a head portion G' which can be coupled to a shank G<sup>2</sup> by means of a coupling G<sup>3</sup> thus enabling the cupping punches proper to be removed and replaced when desired.

In operation, the rim after being rolled to the proper contour is placed within the machine about the sectors I and then when power is applied to the plunger shaft, the plunger is moved downwardly operating upon the sectors I through the medium of the rollers L carried by the arms I', the first portion of said operation serving to stretch and size the rim and simultaneous with the outward movement of the sectors I is the radial inward movement of the cupping sectors F bringing the cupping punches into contact with the rim and punching the cup-like depressions in the base thereof, and when these cup-like depressions are being punched, the inner or convex side of each punch is having a counter depression punched therein by the prick punches M carried by the sector I.

When these various operations are completed, the plunger is reversed and the bell crank levers withdraw the cupping sectors and the springs N force the sizing and punching sectors inwardly and the finished rim can then be removed from the machine.

Having thus described my invention, what I claim is:—

1. In a device of the kind described, the combination with the segments of the outer sectors and means for moving the same, of

the inner sectors and means for moving them outwardly, said sectors being movable upon the segments, and a top plate resting upon the inner sectors and springs interposed between the inner sectors and the segments.

2. In a device of the kind described, the combination with segments, of the outer segments movable thereon, the inner segments resting upon the segments and having inwardly projecting arms having depending lugs, springs between said lugs and said segments, a top plate resting upon the inner segments, a guide ring, a plunger working in said guide ring and acting upon the arms of the sectors, and bell-cranks for moving the outer sectors and means connected with the plunger for moving said bell-cranks.

3. In a machine of the kind described, the vertically movable plunger, the guide ring in which said plunger works, the top plate in which the guide ring is positioned, the inner sectors upon which the top plate rests, the outer sectors, and means for operating the same.

4. In a machine of the kind described, the combination with the segments, of the inner sectors movable thereon, the top plate upon said sectors, the guide ring and plunger, means for moving said plunger, and means interposed between said segments and sectors to move said sectors inwardly, said sectors being moved outwardly by the plunger.

In testimony whereof, I hereunto affix my signature.

HARRY W. KRANZ.