



US 20080121133A1

(19) **United States**

(12) **Patent Application Publication**
Sousa Jaques

(10) **Pub. No.: US 2008/0121133 A1**

(43) **Pub. Date: May 29, 2008**

(54) **PNEUMATIC OR HYDRAULIC TELESCOPIC SYSTEM FOR PYLONS OR CHAIR LIFT STATIONS, GONDOLA LIFTS AND THE LIKE**

Publication Classification

(51) **Int. Cl.**
B61B 11/00 (2006.01)
B61B 10/02 (2006.01)
(52) **U.S. Cl.** **104/173.2; 104/125**
(57) **ABSTRACT**

(76) **Inventor: Americo Cesar Sousa Jaques, Esposende (PT)**

Correspondence Address:
SUGHRUE MION, PLLC
2100 PENNSYLVANIA AVENUE, N.W., SUITE 800
WASHINGTON, DC 20037

(21) **Appl. No.: 11/885,319**

(22) **PCT Filed: Sep. 15, 2005**

(86) **PCT No.: PCT/PT05/00015**

§ 371 (c)(1),
(2), (4) **Date: Aug. 30, 2007**

(30) **Foreign Application Priority Data**

Jun. 1, 2005 (PT) 10047U

The invention concerns a pneumatic or hydraulic telescopic system comprising cylinders concentric at several diameters inserted in the vertical structure of the support pylons (1) and in the departure and arrival stations (14, 16), between the concrete pillar (1) and the nave of the station (15). The sensors are applied on either side of the vehicles (17, 19), facing their forward movement direction, having a reading angle including the entire width of the vehicles. The pneumatic or hydraulic telescopic system (2) is operable: in the support pylons, to adapt the vehicles at the appropriate levels as they travel, causing them to rise or drop depending on the contour of the terrain; in the stations, to compensate the tension of the cable if required. The sensors (18) are operable to analyze the contour of the terrain and inform the control center to actuate the system in accordance with the requirements. Such an overhead cable installation for transporting passengers with said novel elements can operate at different heights relative to the ground.

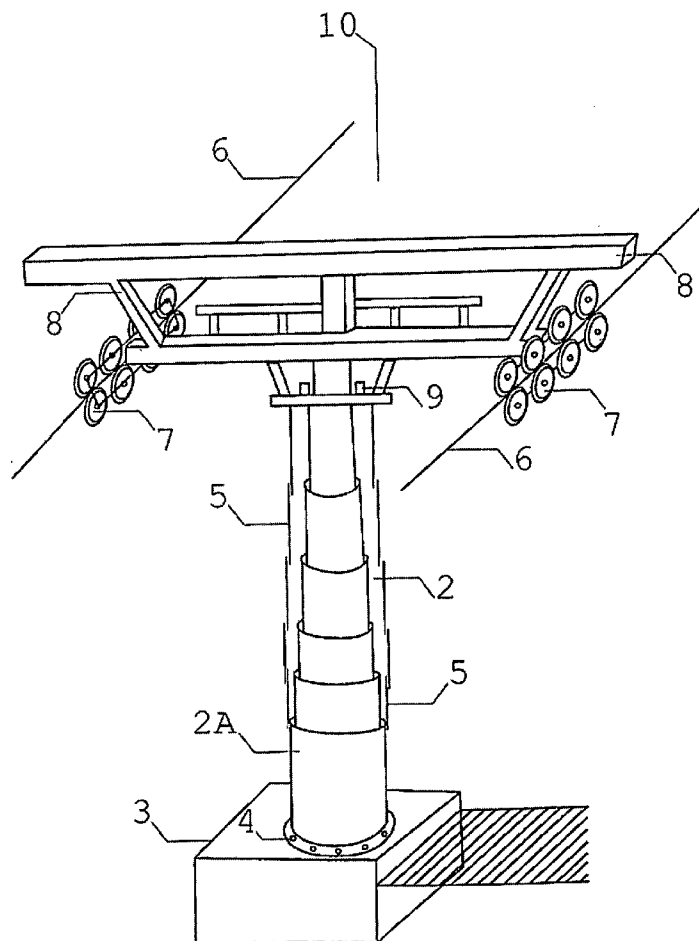

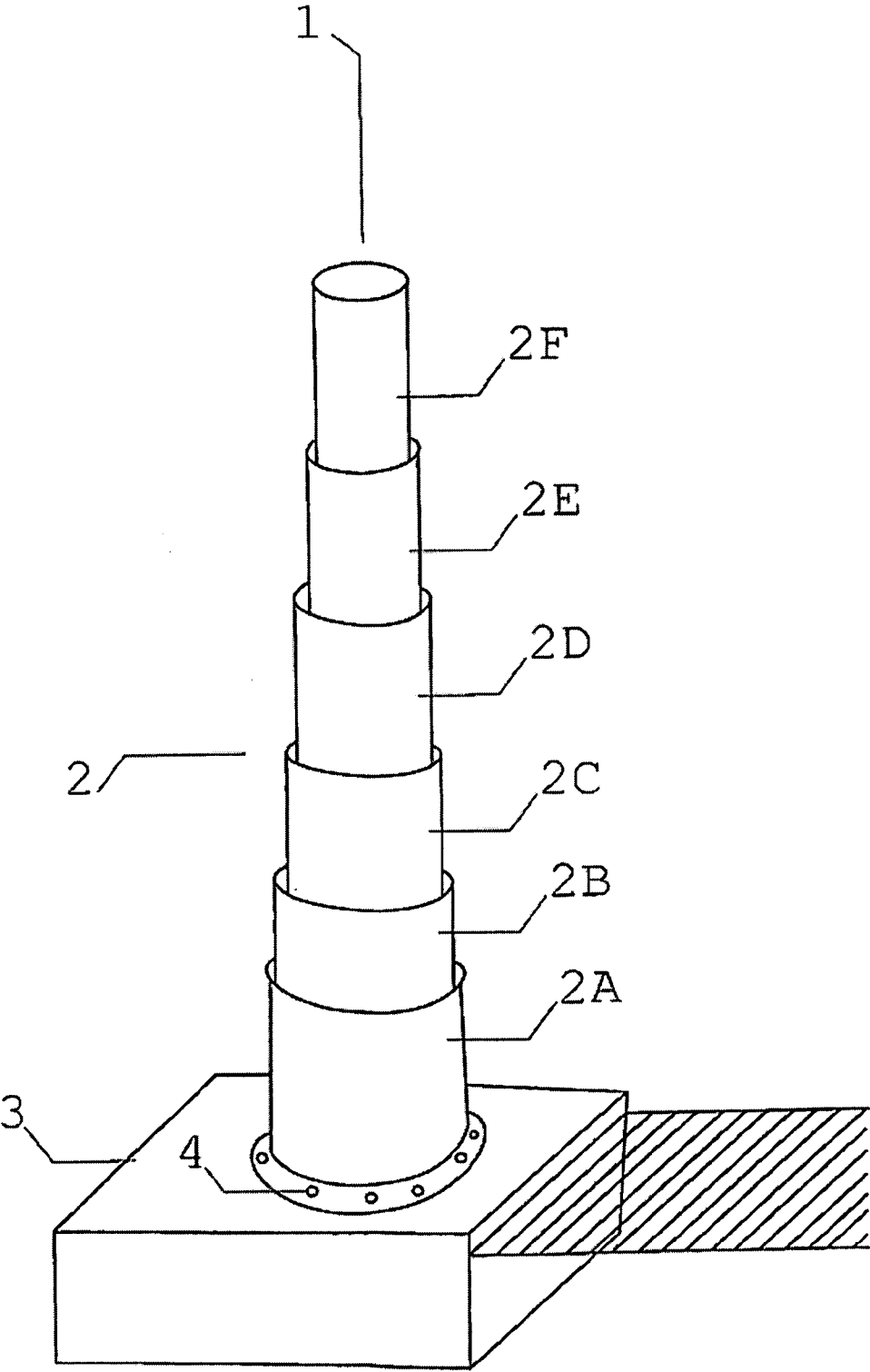

FIG. 1

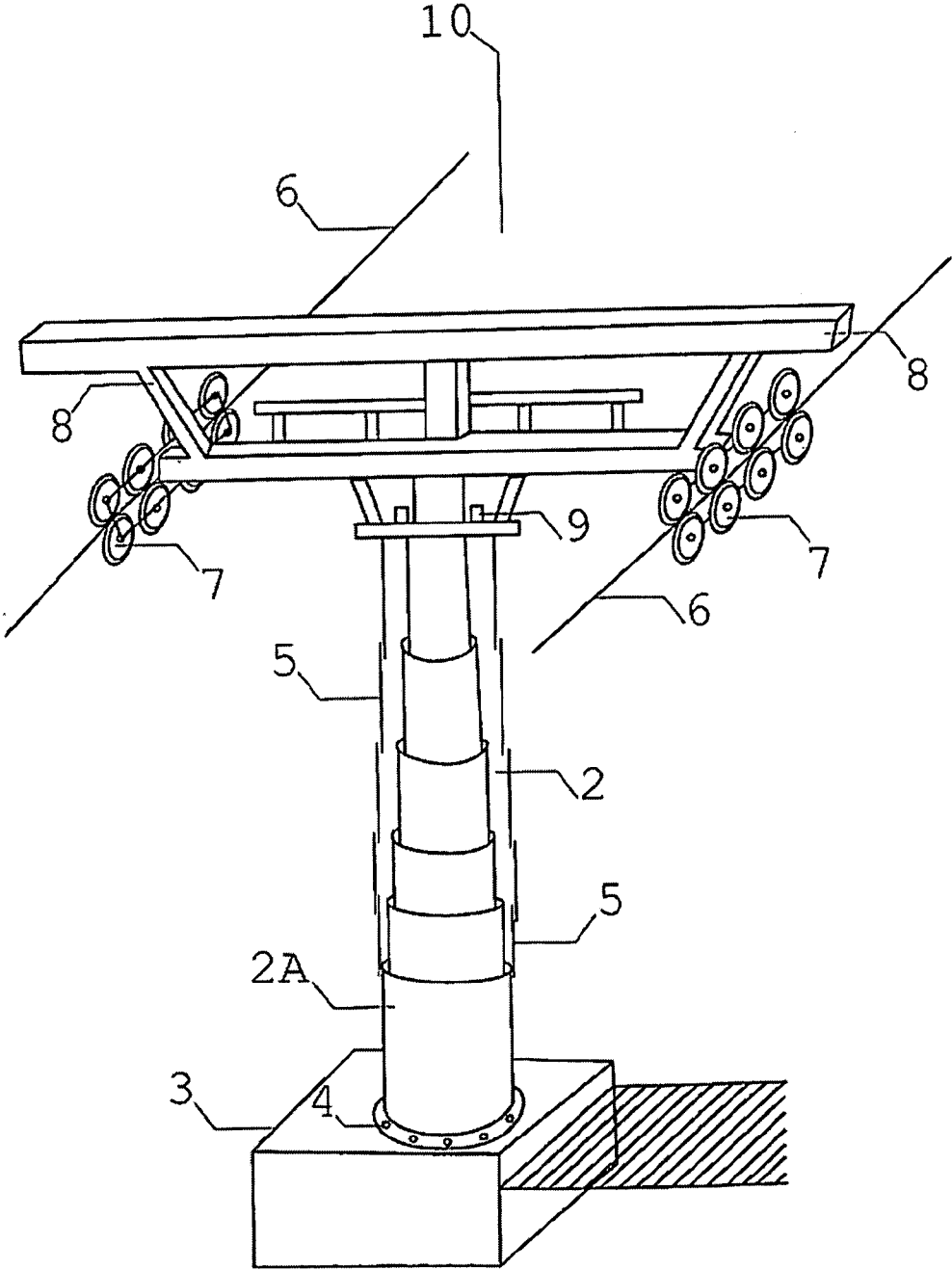

FIG. 2

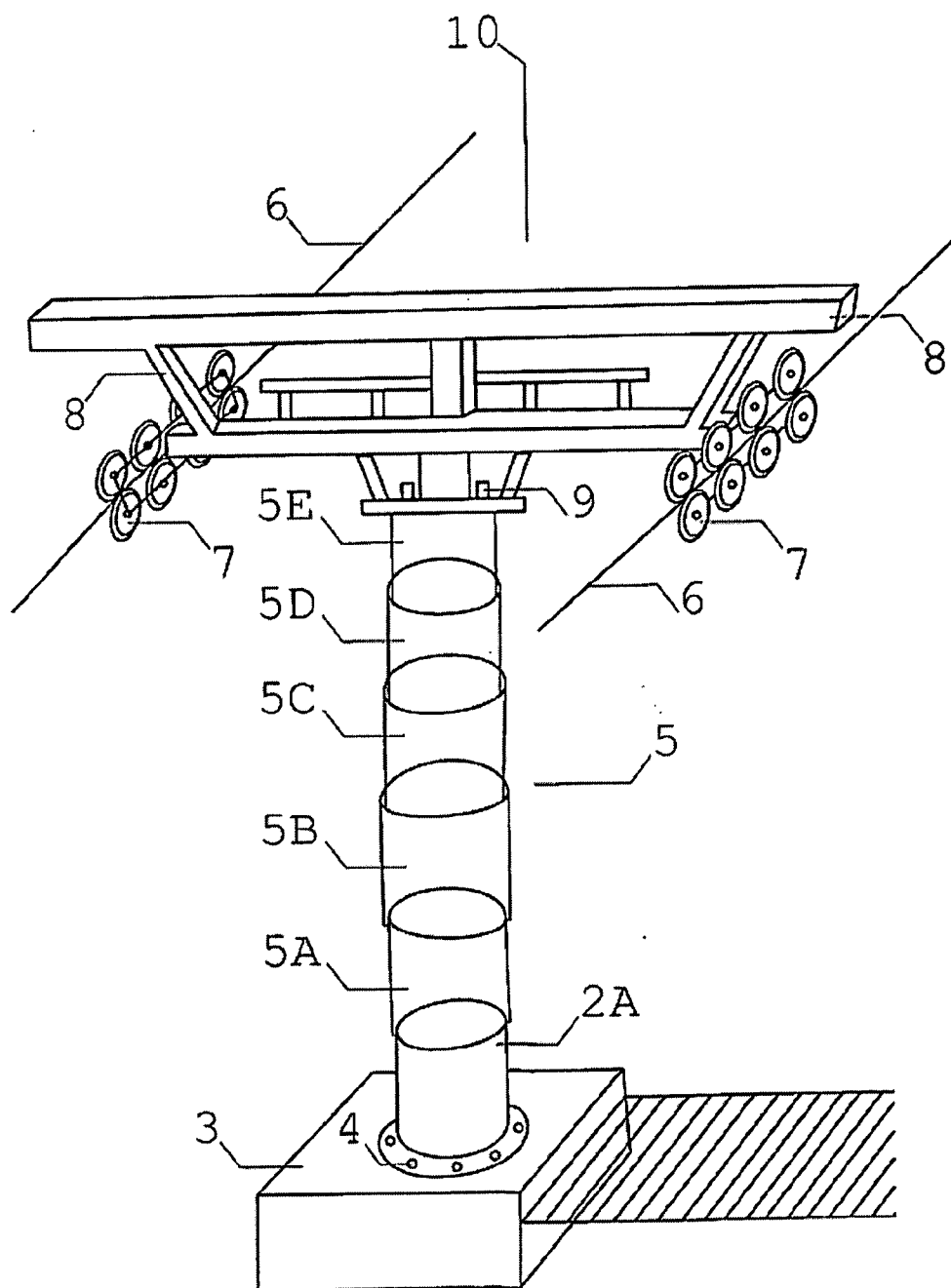

FIG. 3

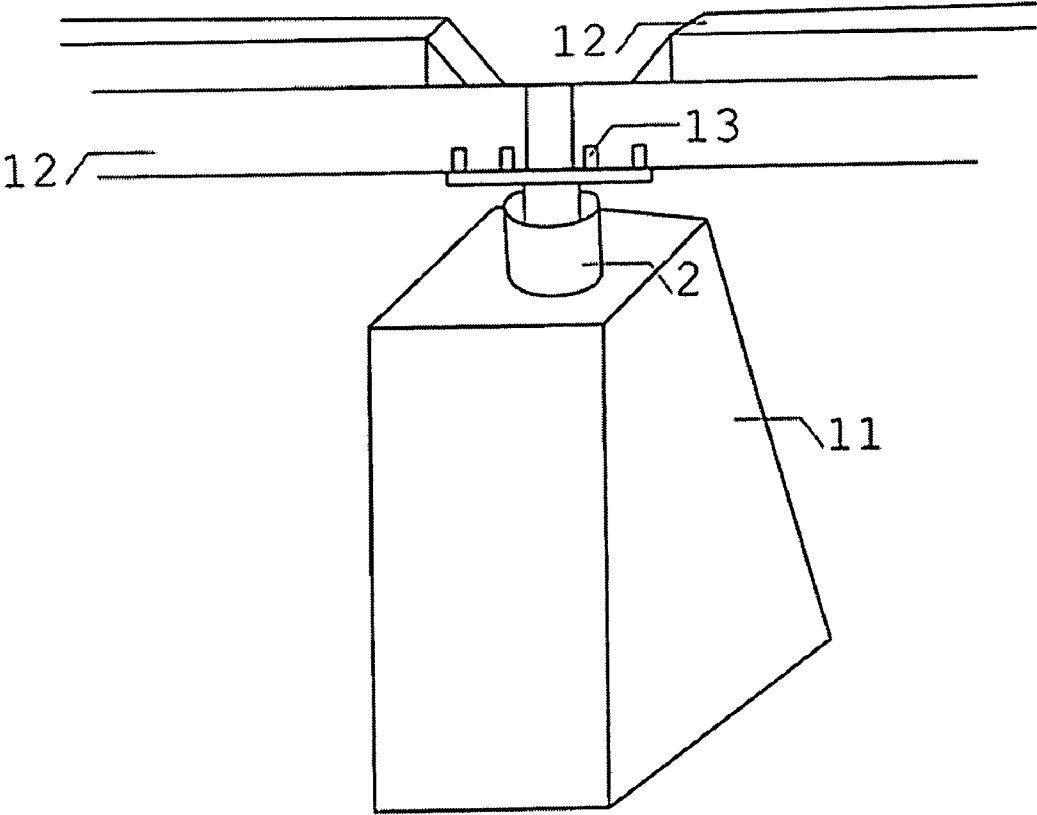

FIG. 4

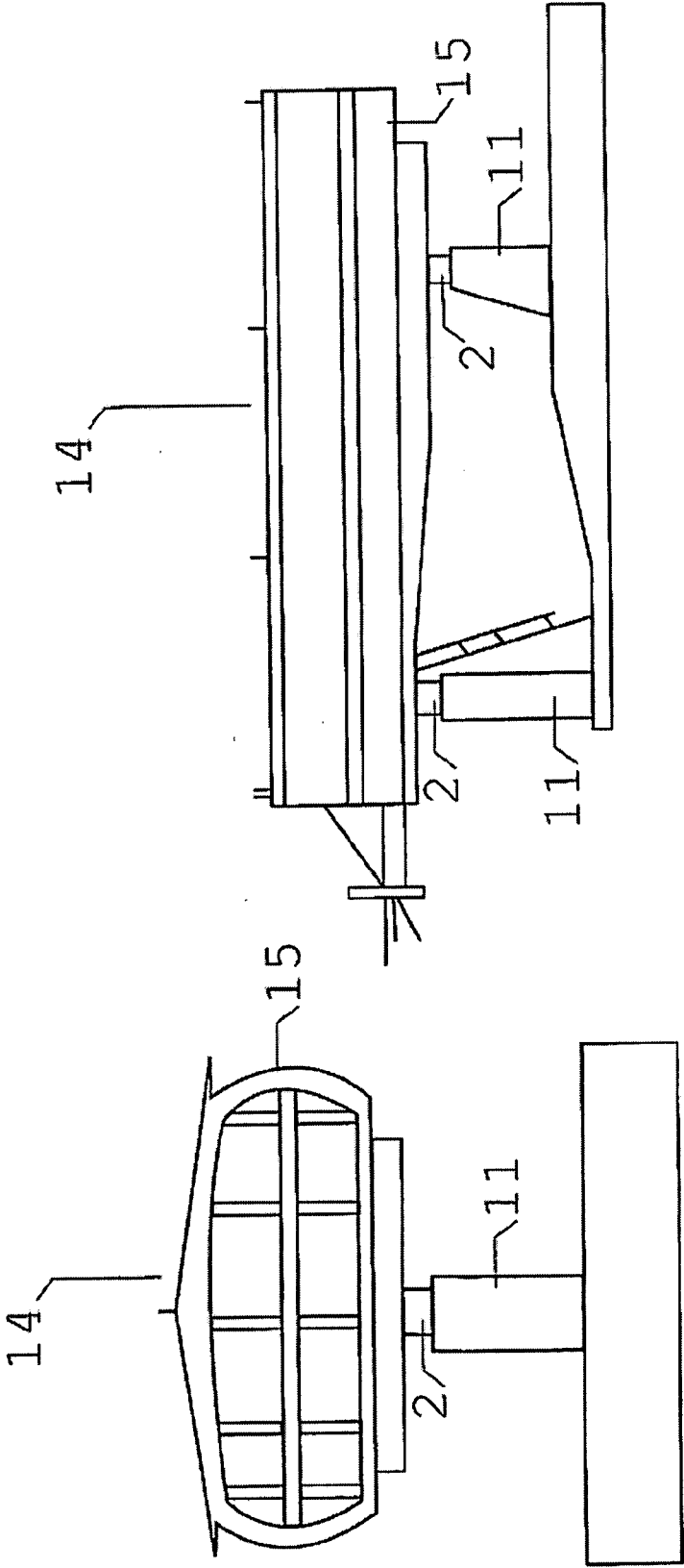

FIG. 5

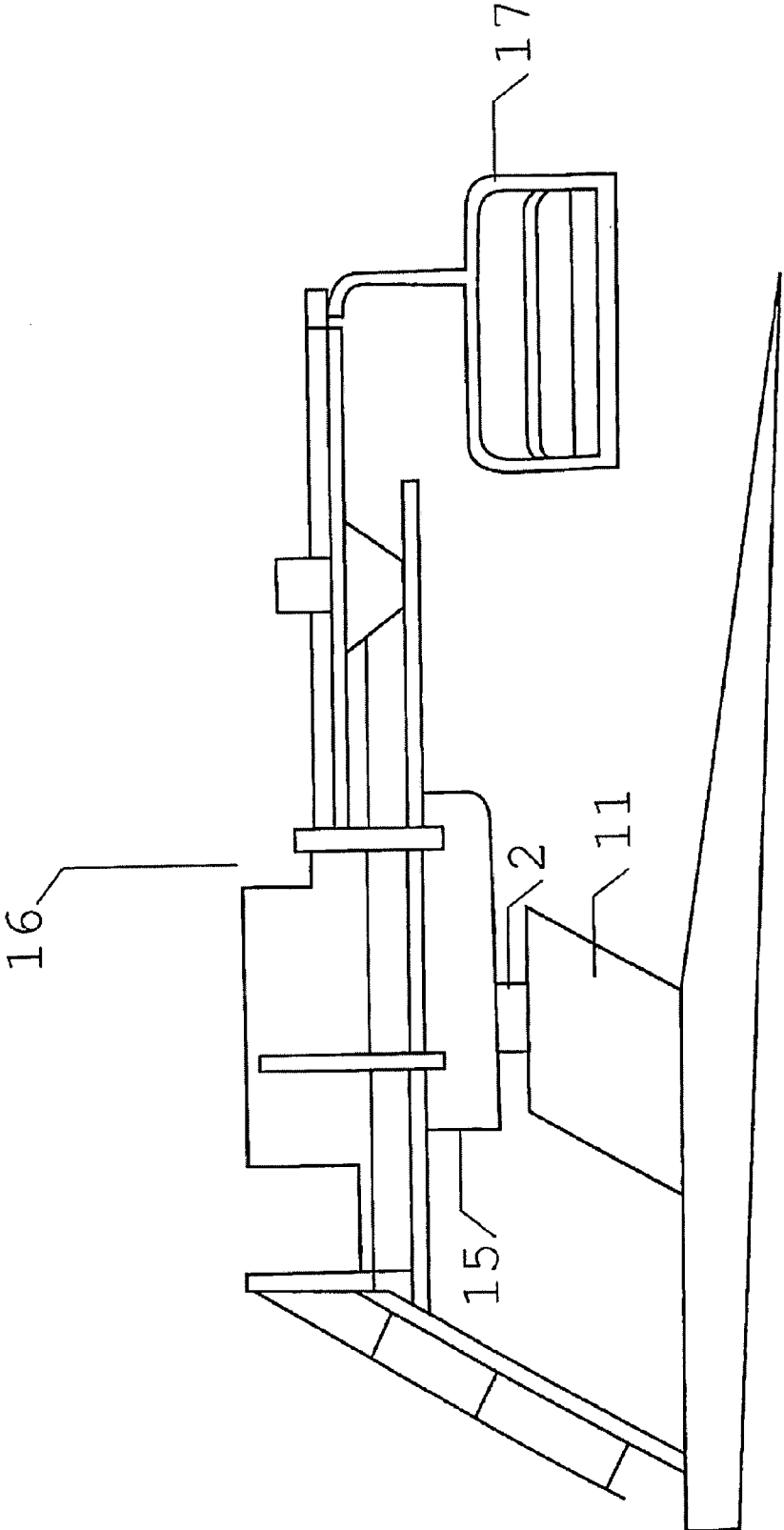

FIG. 6

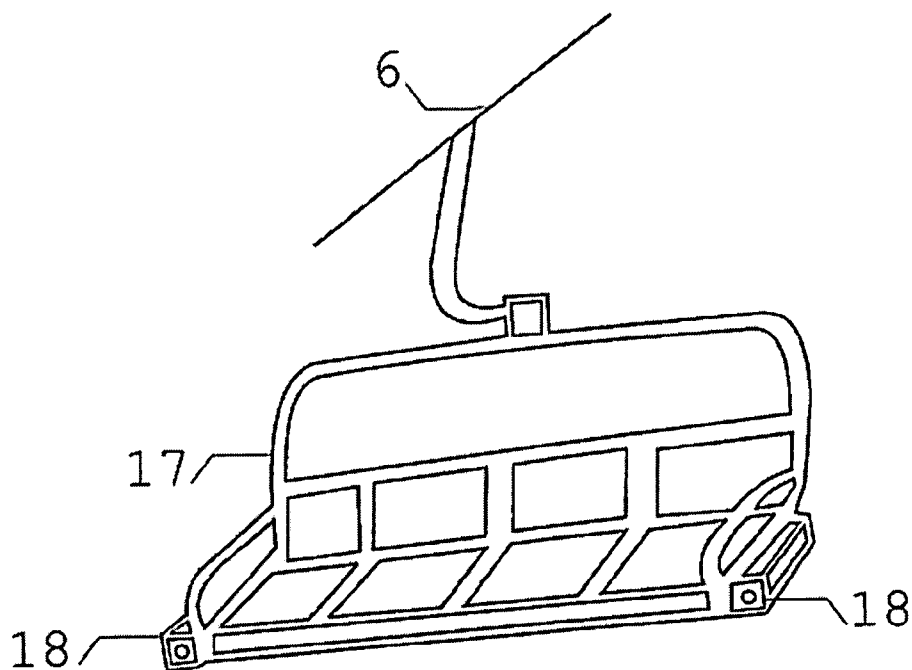

FIG. 7

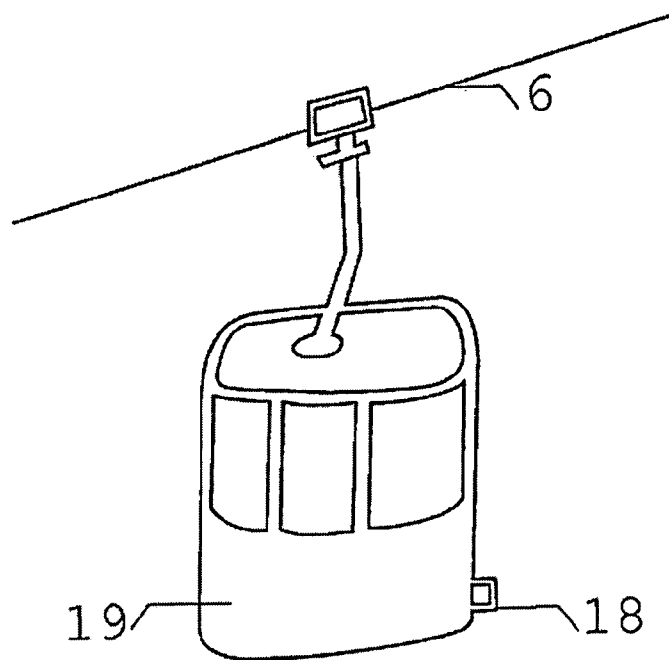

FIG. 8

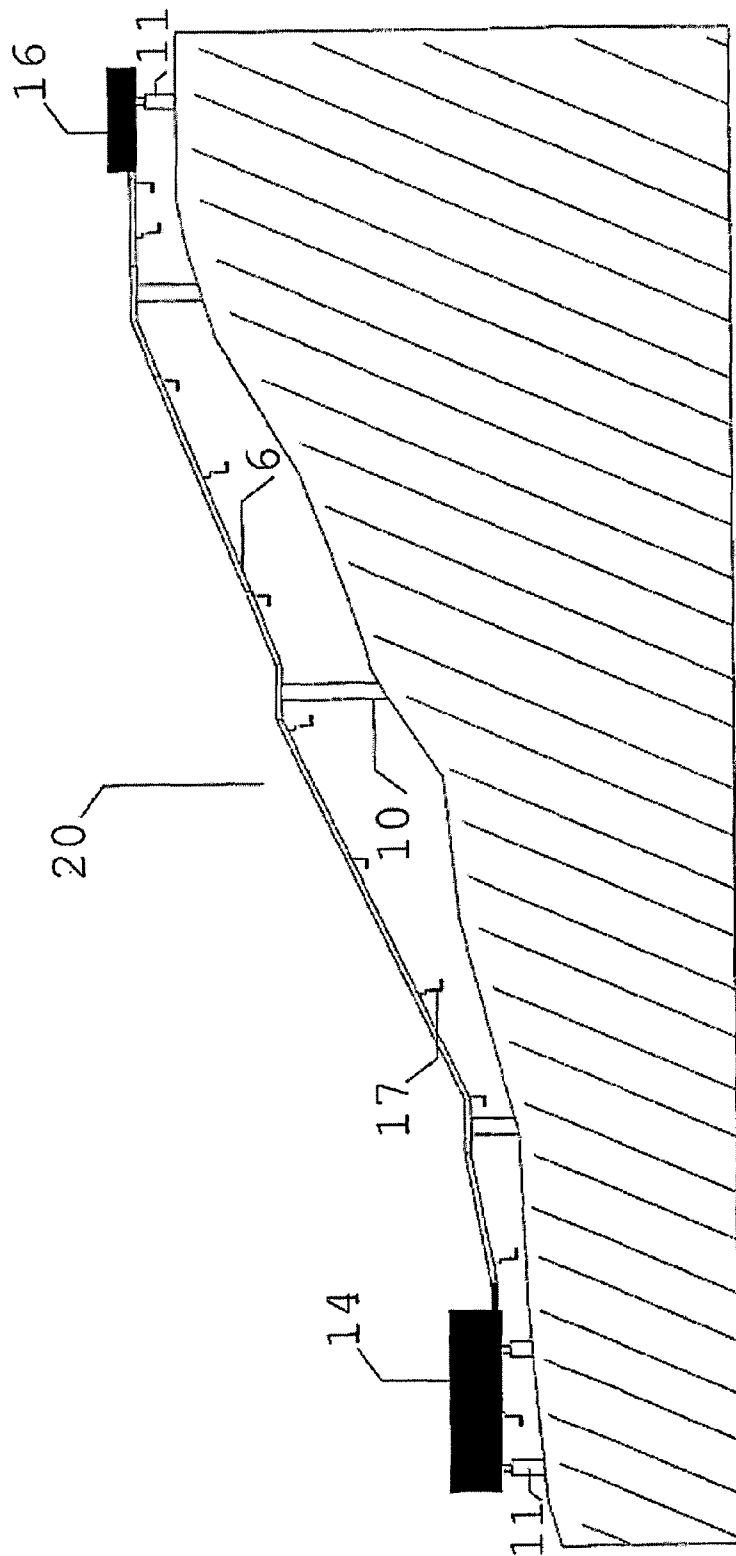

FIG. 9

PNEUMATIC OR HYDRAULIC TELESCOPIC SYSTEM FOR PYLONS OR CHAIR LIFT STATIONS, GONDOLA LIFTS AND THE LIKE

[0001] The invention relates to the implementation of a pneumatic or hydraulic telescopic system in the support towers and stations of the air transport installations by cable destined to passengers: Chairlifts, Gondolalifts and the like.

[0002] Presently, such a transport installation comprises at least one tractor-transporter cable forming a ring between the departure and arrival stations, an undetermined number of chairs or cabins settled to the said movable cable with a predefined distance between them, a device of motorization to place the cable in rotation and some support towers of the cable along the route.

[0003] The support towers generally comprise a concrete foundation in the ground, a vertical structure fixed to the said concrete foundation and a horizontal structure with pulleys where the cable passes through with the chairs or cabins.

[0004] The stations comprise at least a concrete pillar, where the station aisle is fixed, a motive wheel in case of the station motive, that is generally the departure station, and a wheel for inverting the direction of the cable in the station of return, which is generally the departure station.

[0005] In the present prior art the abovementioned transport installation is at a constant height from the ground, normally considerable heights throughout the entire route. Therefore, under strong wind or stormy weather, the chairs or cabins are more exposed, compromising the security of users.

[0006] Normally, these installations comprise equipment that makes them stop when the wind speeds ascends 60 km/h, compromising the security of users who are travelling along the route. In such situation, specialized rescue teams are obliged to intervene, always in complex and lasting maneuvers. Such situations might have ominous consequences for the intervening users and high costs for operating companies.

[0007] In other cases, one cannot guarantee, in the beginning of each journey, safety conditions of the installations' operation. In this in case the installations do not pull out, which leads to the loss of income for the operating company.

[0008] The aim of the invention is to solve the problems mentioned in paragraphs [005], [006] and [007].

[0009] The object of the invention consists in the implementation of

[0010] a pneumatic or hydraulic telescopic system in the support towers and motive and return stations;

[0011] appropriate sensors in the chairs or cabins.

[0012] This system allows the vehicles adjustment to several distances from the ground, being the entire installation able to follow the land's morphology, in order to withdraw the risks inherent to strong winds and to increase the users' security.

[0013] However, if the installation can operate at a low height from the ground, the incidence of the wind in the chairs or cabins diminishes, thus increasing the users' security.

[0014] However this system also facilitates the rescue of users if necessary, since with the pneumatic or hydraulic telescopic system enables the vehicles to be placed at ground level in any point of the course.

[0015] Another advantage of the invention concerns the fact that, currently, one is not able to guarantee, in the beginning of each journey, the safety conditions throughout the whole course, being the case in some the ski resorts.

[0016] In this case, the invention enables the installation to operate until the place where safety is guaranteed, creating for such a snow platform and lowering the installation to the required levels. In this way the loss of income is reduced for the operating company.

[0017] One of the key elements of the invention is a pneumatic or hydraulic telescopic system that operates the support towers and stations to move in the ascending or descending direction according to the requirements.

[0018] For an optimization and resistance of the pneumatic or hydraulic telescopic system, the cylinders that compose it must be manufactured in steel and there should be a protection or defense fuselage in the system. This fuselage will obligatory be telescopic to follow the movement of the system it contains inside.

[0019] Another key element of the invention are the sensors to be placed in the chairs or cabins. In each chair or cabin two sensors are settled, one on the left side and the other on the right side of the vehicle, being both faced towards the direction of the route. Moreover the scanning angle of the sensors must enclose the whole width of the chairs or cabins.

[0020] These sensors aim to detect the distance from ground along the course, when the installation is operating at considerable low levels, adjust the support towers to the adequate level and, consequently, ensure that no chair collides into an obstacle.

[0021] The mechanical interaction between these two elements (telescopic system and sensors) is occurs in the following manner: the sensors detect an obstacle, send the information to the central office which, in its turn, activates the towers according to the predetermined directives and, consequently, the cable and the vehicles that it sustains.

[0022] The enclosed figures allow a better description and understanding of the invention, in which:

[0023] FIG. 1 represents the pneumatic or hydraulic telescopic system and its fixing mechanics to the ground;

[0024] FIG. 2 represents a support tower with the pneumatic or hydraulic telescopic system of FIG. 1, the horizontal structure of support and the protection fuselage of the system;

[0025] FIG. 3 represents the support tower in FIG. 2 with the protection fuselage of the telescopic system and an overview of the operation;

[0026] FIG. 4 represents a detail of the insertion and setting of the telescopic pneumatic or hydraulic telescopic system in the stations;

[0027] FIG. 5 represents two frontal and lateral projections of motor station and the insertion of the pneumatic or hydraulic telescopic system of FIG. 4;

[0028] FIG. 6 represents a lateral and vertical projection of a return station and the implementation of the pneumatic or hydraulic telescopic system of FIG. 4;

[0029] FIG. 7 represents the frontal and vertical projection of a chair, with the armored boxes that contain the sensors;

[0030] FIG. 8 represents a vertical and lateral projection of a cabin with the armored box that contains a sensor;

[0031] FIG. 9 is a schematic representation of a transport installation by cable—Chairlift or Gondola lift.

[0032] FIG. 1 represents vertical structure 1 of the support tower 10 of a transport installation by cable 20.

[0033] The vertical structure 1 comprises several cylinders 2A 2F with different diameters. The base cylinder 2A is fixed and has the largest diameter, the following cylinder 2B has a smaller diameter to work inside the base cylinder 2A and thus successively.

[0034] The fixed base 2A of vertical structure 1 is attached to the concrete foundation 3 by means of screws. The pneumatic or hydraulic telescopic system 2 receives at its end the horizontal support structure 8 which contains in turn the pulleys 7 for a good sliding of cable 6, the chairs 17 or cabins 19.

[0035] The horizontal support structure 8 is attached to the pneumatic or hydraulic telescopic system 2 of the vertical structure 1 by means of a rabbet 9 and screws for a higher resistance.

[0036] This horizontal structure 8 is altered at the level of pulleys 7, taking two rows of pulleys 7 instead of one, a superior row and an inferior row lined, because cable 6 passes between them. So being, when it becomes necessary to raise or lower towers 10, the cable 6 which runs between both rows of pulleys 7, is submitted to a certain pressure, either by the inferior or the superior pulleys 7, following the movement of towers 10. Consequently, it becomes rather improbable for cable 6 to be released.

[0037] As previously described in paragraph [016], the pneumatic or hydraulic telescopic system 2 must have a protection fuselage 5. This fuselage 5, also telescopic, must be in steel alloy in cylindrical and hollow form. The cylinder 5A operates outside the fixed base 2A and the cylinder 5B operates outside the cylinder 5A. However, the cylinder 5C operates the inside cylinder 5B and thus successively. All fuselage works in a rail.

[0038] However the installation 20 must operate together, as a whole, both in the ascending and descending direction, or with the flexibility allowed by the tension of cable 6.

[0039] The tension of cable 6 can be compensated with the implementation of the pneumatic or hydraulic telescopic system 2 in stations 14,16 being other compensation methods possible.

[0040] In stations 14,16 the pneumatic or hydraulic telescopic system 2 is settled between the concrete pillar or pillars 11 and the structure 12 which sustains the aisle 15 of station 14,16, through a setting in U and screws 13 presenting the dimensions demanded by the structure. However the system is also attached to the superior end of the concrete pillar 11 by means of the same technique previously described for the settlement of the pneumatic or hydraulic telescopic system 2 to the concrete foundation 3.

[0041] In this case the pneumatic or hydraulic telescopic system 2 does not require the same dimensions as the support 10, since the task of the telescopic system 2 in stations 14,16 is to compensate the tension of cable 6 thus elevating or lowering them when necessary. The implementation spot of the pneumatic or hydraulic telescopic system 2 is always between the concrete pillar 11 and the station's aisle 15, despite the type of station 14,16.

[0042] The sensors 18 are applied in chairs 17 or cabins 19 inside a shielded box for protection purposes. Two sensors 18 must be placed in vehicles 17 and 19, one on the left side and the other on the right side of the vehicle, being both turned towards the route. The scanning angle of the sensors must enclose all the entire width of chairs 17 or cabins 19.

1. Pneumatic or hydraulic telescopic system for chairlifts, gondola lifts and the like including a transport installation comprising:

- at least one tractor-transporter cable forming a ring between the departure station and arrival station;
- a plurality of chairs or cabins fixed to the said cable at a predefined distance between them;
- a device of motorization to place the cable in rotation and several support towers of the cable along the course;

comprising a pneumatic or hydraulic telescopic system, which lowers and raises the vehicles according to the instructions of the operator, consisting of concentric cylinders of various diameters, in the towers of support, in the departure station and arrival station, and sensors that detect the level of the land so that the chairs and cabins do not shock with obstacles.

2. Pneumatic or hydraulic telescopic system for chairlifts, gondola lifts and the like according to claim 1 comprising a pneumatic or hydraulic telescopic system in support towers with a fuselage of cylindrical protection, hollow and also telescopic, which receives in its upper end a horizontal support structure with two rows of pulleys and a cable that passes between the said rows of pulleys in order to settle the cable between them not letting it be released, when the support towers are in an ascending or descending movement.

3. Pneumatic or hydraulic telescopic system for chairlifts gondola lifts and the like according to claim 1 comprising a pneumatic or hydraulic telescopic system in which the cylinder of the base is immovable and fixed to the concrete foundation through a setting with screws and the horizontal structure of support is attached to the pneumatic or hydraulic telescopic system through a setting for rabbet and with screws for a higher resistance.

4. Pneumatic or hydraulic telescopic system for chairlifts gondola lifts and the like according to claim 1 wherein, in stations of traction and return, the pneumatic or hydraulic telescopic system is placed between the pillar or concrete pillars and the structure, that sustains the aisle, and is attached to the said structure through a setting in U and screws with the measures required by the structure.

5. Pneumatic or hydraulic telescopic system for chairlifts gondola lifts and the like according to claim 1 wherein it is attached in the upper end of the concrete pillar with the same technical procedure as the pneumatic or hydraulic telescopic system is fixed to the concrete foundation.

6. Pneumatic or hydraulic telescopic system for chairlifts gondola lifts and the like according to claim 1 wherein the transport installation is formed by a pneumatic or hydraulic telescopic system inserted in the support towers and in the traction and return stations, in order to elevate or lower the support towers according to the necessities.

7. Pneumatic or hydraulic telescopic system for chairlifts gondola lifts and the like according to claim 1 wherein the transport installation comprises sensors placed in the chairs or cabins, whose function is to detect the level of the land or eventual obstacles along the course, when the installation is operating at considerable low distances from the ground and to adjust the support towers at the adequate level.

8. Pneumatic or hydraulic telescopic system for chairlifts gondola lifts and the like according to claim 1 wherein two sensors are placed in the vehicles, one on the left side and the other on the right side, facing towards the direction of the route.

9. Pneumatic or hydraulic telescopic system for chairlifts gondola lifts and the like according to claim 1 wherein the scanning angle of the sensors encloses the whole width of the chairs or cabins.

10. Pneumatic or hydraulic telescopic system for chairlifts gondola lifts and the like according to claim 1 wherein in the detection of some obstacle, the sensors send the information to the central office and this, in its turn, activates the support towers and adjusts them according to programmed directives and, consequently, the cable and the vehicles that it sustains.