



INTERNATIONAL APPLICATION PUBLISHED UNDER THE PATENT COOPERATION TREATY (PCT)

<p>(51) International Patent Classification <sup>6</sup> : <b>A61M 25/01 // 25/09</b></p>	<p><b>A1</b></p>	<p>(11) International Publication Number: <b>WO 97/26936</b> (43) International Publication Date: 31 July 1997 (31.07.97)</p>
<p>(21) International Application Number: PCT/AU97/00046 (22) International Filing Date: 28 January 1997 (28.01.97) (30) Priority Data: PN 7752 25 January 1996 (25.01.96) AU (71) Applicant (for all designated States except US): ENDOGAD RESEARCH PTY. LIMITED [AU/AU]; Level 25, 135 King Street, Sydney, NSW 2000 (AU). (72) Inventors; and (75) Inventors/Applicants (for US only): WHITE, Geoffrey, H. [AU/AU]; 22 Nicholson Street, East Balmain, NSW 2041 (AU). YU, Weijun [AU/AU]; 34/2 Friend Avenue, Five Dock, NSW 2046 (AU). (74) Agent: F.B. RICE &amp; CO.; 28A Montague Street, Balmain, NSW 2041 (AU).</p>		<p>(81) Designated States: AL, AM, AT, AU, AZ, BA, BB, BG, BR, BY, CA, CH, CN, CU, CZ, DE, DK, EE, ES, FI, GB, GE, HU, IL, IS, JP, KE, KG, KP, KR, KZ, LC, LK, LR, LS, LT, LU, LV, MD, MG, MK, MN, MW, MX, NO, NZ, PL, PT, RO, RU, SD, SE, SG, SI, SK, TJ, TM, TR, TT, UA, UG, US, UZ, VN, ARIPO patent (KE, LS, MW, SD, SZ, UG), Eurasian patent (AM, AZ, BY, KG, KZ, MD, RU, TJ, TM), European patent (AT, BE, CH, DE, DK, ES, FI, FR, GB, GR, IE, IT, LU, MC, NL, PT, SE), OAPI patent (BF, BJ, CF, CG, CI, CM, GA, GN, ML, MR, NE, SN, TD, TG).</p> <p><b>Published</b> <i>With international search report.</i></p>

(54) Title: DIRECTIONAL CATHETER

(57) Abstract

An intraluminal catheter (24) for directing a guidewire (26) and/or catheter (26a) in a desired direction within a bodily vessel or cavity. The intraluminal catheter (24) has a first elongate tubular member (52) and a support means which can comprise a second elongate tubular member (51) that can pass over a main support guidewire (23). The catheter (24) acts as a platform as the guidewire (26) is passed through the first elongate tubular member (52) and is deflected transversely outwardly by an angled surface (54) through an aperture (50). A second intraluminal catheter (60) has a first elongate tubular member (63) and a support means comprising a second elongate tubular member (61). The first elongate tubular member (63) has a main portion (65) and an end portion (66), with the end portion (66) being deflectable relative to the locus of the main portion so as to direct the guidewire (26) passing through the end portion (66) in a desired direction in the bodily vessel.

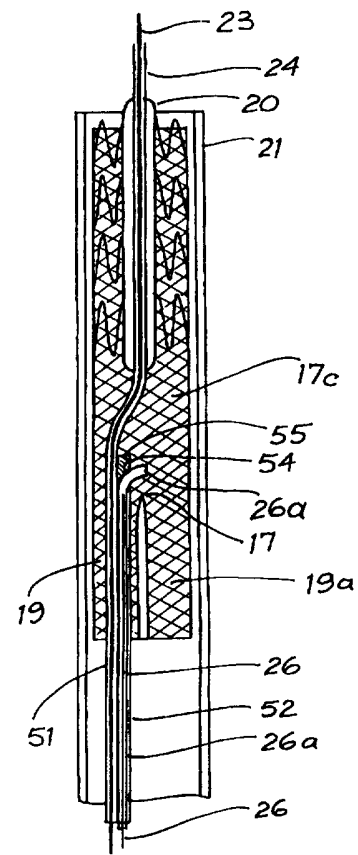

**FOR THE PURPOSES OF INFORMATION ONLY**

Codes used to identify States party to the PCT on the front pages of pamphlets publishing international applications under the PCT.

AM	Armenia	GB	United Kingdom	MW	Malawi
AT	Austria	GE	Georgia	MX	Mexico
AU	Australia	GN	Guinea	NE	Niger
BB	Barbados	GR	Greece	NL	Netherlands
BE	Belgium	HU	Hungary	NO	Norway
BF	Burkina Faso	IE	Ireland	NZ	New Zealand
BG	Bulgaria	IT	Italy	PL	Poland
BJ	Benin	JP	Japan	PT	Portugal
BR	Brazil	KE	Kenya	RO	Romania
BY	Belarus	KG	Kyrgystan	RU	Russian Federation
CA	Canada	KP	Democratic People's Republic of Korea	SD	Sudan
CF	Central African Republic	KR	Republic of Korea	SE	Sweden
CG	Congo	KZ	Kazakhstan	SG	Singapore
CH	Switzerland	LI	Liechtenstein	SI	Slovenia
CI	Côte d'Ivoire	LK	Sri Lanka	SK	Slovakia
CM	Cameroon	LR	Liberia	SN	Senegal
CN	China	LT	Lithuania	SZ	Swaziland
CS	Czechoslovakia	LU	Luxembourg	TD	Chad
CZ	Czech Republic	LV	Latvia	TG	Togo
DE	Germany	MC	Monaco	TJ	Tajikistan
DK	Denmark	MD	Republic of Moldova	TT	Trinidad and Tobago
EE	Estonia	MG	Madagascar	UA	Ukraine
ES	Spain	ML	Mali	UG	Uganda
FI	Finland	MN	Mongolia	US	United States of America
FR	France	MR	Mauritania	UZ	Uzbekistan
GA	Gabon			VN	Viet Nam

"DIRECTIONAL CATHETER"Field of the Invention

The present invention relates to catheters and particularly to directional catheters for use in medical applications.

5 Background Art

The placement of prosthetic devices, such as stents and grafts, intraluminally and the conduct of operative procedures intraluminally has grown dramatically in recent years. In many of these placements and procedures, it is necessary to initially position a guidewire into a desired part  
10 of the lumen of a desired vessel or duct, such as a blood vessel. Once an initial guidewire is in place, a catheter or other tubular device may be positioned over the guidewire and used to convey another guidewire, a prosthesis, an endoscope or a surgical instrument into the desired blood vessel or duct.

15 There are a variety of techniques used to position guidewires in branching vessels intraluminally. One technique is to position a relatively stiff guidewire in a bodily vessel and then to pass over it a catheter having a region proximate its tip that normally assumes an angled, curved or some other configuration. On positioning the catheter over the stiff guidewire in  
20 the necessary position, the stiff guidewire is withdrawn allowing the region near the tip of the catheter to assume its normal configuration. A thin guidewire can then be fed through the catheter and directed in the direction assumed by the catheter. The thin guidewire is preferably sufficiently floppy that it is directed by the catheter in the direction assumed by the catheter  
25 rather than causing the catheter to adopt the configuration of the thin guidewire. As the first stiff guidewire must firstly be removed to allow the insertion of the thin guidewire, it is clinically undesirable to re-insert the stiff guidewire if required at a later time. Further, withdrawal of the stiff guidewire leads to there being no control over the position assumed by the  
30 catheter and it is common for the catheter to assume an undesirable position thereby requiring re-insertion of the stiff guidewire to correct the situation. The strength of the catheter further limits the stiffness of the thin guidewire or another secondary catheter that may be subsequently inserted through the catheter which can lead to further complications in successfully positioning  
35 a guidewire through the branching bodily vessel.

One example of a guiding catheter is described in US 4898577 to Badger *et al.* The Badger guiding catheter comprises a single elongated shaft having a deflectable distal portion, the angle of deflection of the distal portion relative to the elongated shaft being controlled by a pull wire that extends from the distal portion back through a lumen to a proximal end of the catheter where it can be controlled by a physician. Once the distal portion is at the required deflection, the guidewire is fed through the catheter.

Another type of directable catheter is the so-called torquable catheter, an example of which is described in Australian Patent Specification AU-A-32951/95 to Lundquist. The Lundquist catheter once again has a single elongated shaft which has a flexible portion which can bend under the control of a physician to deflect the end of the catheter and so direct a guidewire passing therethrough in a desired direction.

Even with directable or torquable catheters, physicians still often encounter problems in achieving desired placement of guidewires and catheters in bodily vessels. Problems are especially encountered when it is necessary to direct a guidewire into a vessel branching of the main vessel. Conversely, problems also arise of a guidewire undesirably entering a branching vessel instead of remaining in the main vessel.

One example where it is often necessary to direct a guidewire into a branching vessel is in the placement of an intraluminal graft into a patient to achieve bridging and occlusion of an aneurysm of the aorta, iliac or other arteries. The present invention is directed to an alternative directional catheter which can be used for the intraluminal placement of a guidewire or catheter in a bodily vessel or cavity.

#### Disclosure of the Invention

The present inventors have determined that substantial advantages over traditional techniques can be gained by positioning a main guidewire in a bodily vessel and then using that guidewire as a platform to insert and support a catheter, which catheter can be used to direct a supplementary guidewire and/or catheter in a direction transverse to the locus of the main guidewire.

Accordingly, in a first aspect, the present invention consists in an intraluminal catheter for insertion through a bodily vessel, the catheter having a first elongate tubular member defining a first lumen, the tubular

member having on its outer surface a support means adapted to slide over a main guidewire positioned in the vessel, the first elongate tubular member having directing means to direct a supplementary guidewire passing through the first lumen into the bodily vessel in a direction transverse to the locus of the main guidewire

5

The provision of the support means on the intraluminal catheter allows the intraluminal catheter to be supported on the main guidewire already positioned in a bodily vessel as the supplementary guidewire is fed through the first lumen. The use of such a catheter removes the need to withdraw the stiff guidewire before insertion of the supplementary guidewire. Further, the support during deployment of the supplementary guidewire ensures the guidewire is deployed in a direction desired by the physician transverse to the locus of the main guidewire.

10

In one embodiment, the support means can comprise a second elongate tubular member in side-by-side configuration with the first tubular member. The second tubular member can be at least as long as the first elongate tubular member. The catheter can also have a third or further number of lumens.

15

The directing means can comprise deflection means disposed on the catheter, the deflection means including a surface angled to the locus of the first lumen or an extension thereof such that the supplementary guidewire on passing through the first lumen will be deflected laterally out of the locus of the first lumen or the extension thereof. The angled surface is preferably positioned within the first lumen with the first tubular member having an aperture opposite the angled surface such that the supplementary catheter on passing through the first lumen is deflected by the angled surface through the aperture. The angled surface can be proximate a free end of the first tubular member.

20

25

In another embodiment, the first tubular member can have a main portion and the directing means can comprise an end portion of the tubular member that is deflectable relative to the locus of the main portion.

30

In a further embodiment, a control wire can extend along the catheter and be secured to the end portion with retraction of the control wire relative to the catheter deflecting the end portion relative to the locus of the main portion. If desired, the control wire can be disposed within a further lumen of the catheter.

35

The main portion of the first tubular member can normally assume a straight configuration and the end portion can normally assume a curved configuration, the catheter further having a sleeve that is relatively movable longitudinally with respect to the first tubular member between a first position where the sleeve surrounds the end portion and so straightens the end portion and a second retracted position where the end portion is free to assume its normal curved configuration.

In this specification, the normal configuration of the first tubular member according to the present invention is taken to be configuration adopted by the tubular member when the catheter is outside the body and the sleeve is in the second retracted position relative to the first tubular member.

In another embodiment, the main portion can normally assume a straight configuration and the end portion can be preformed at an angle to the main portion, the catheter further having a sleeve that is relatively movable longitudinally with respect to the first tubular member between a first position where the sleeve surrounds the end portion and so straightens the end portion and a second retracted position where the end portion is free to assume its preformed angle to the main portion.

The end portion of the catheter is preferably fabricated from a shape memory material that will adopt the normally curved or angled configuration when the catheter is in the desired position in the bodily vessel and the sleeve is retracted relative to the first tubular member.

The catheter is preferably dimensioned such that it can be introduced into the bodily vessel through an 18 French introducer sheath.

According to a second aspect, the present invention comprises an intraluminal catheter for insertion through a bodily vessel, the catheter having a first elongate tubular member defining a first lumen, the tubular member having on its outer surface a support means adapted to slide over a main guidewire positioned in the vessel, the first tubular member having deflection means disposed on the catheter, the deflection means including a surface angled to the locus of the first lumen or an extension thereof such that a supplementary guidewire passing through the first lumen will be directed laterally out of the locus of the first lumen or the extension thereof.

According to a third aspect, the present invention comprises an intraluminal catheter for insertion through a bodily vessel, the catheter

having a first elongate tubular member defining a first lumen, the tubular member having on its outer surface a support means adapted to slide over a main guidewire positioned in the vessel, the first elongate tubular member having a main portion and an end portion wherein the main portion normally assumes a straight configuration and the end portion normally assumes a curved configuration, the catheter further having a sleeve that is relatively movable longitudinally with respect to the first tubular member between a first position where the sleeve surrounds the end portion and so straightens the end portion and a second retracted position where the end portion is free to assume its normal curved configuration.

According to a fourth aspect, the present invention comprises a kit for directing a supplementary guidewire in a direction transverse to the locus of a main guidewire positioned in a bodily vessel, the kit comprising an intraluminal catheter having a first elongate tubular member having a first lumen, the tubular member having a support means on its outer surface adapted to slide over the main guidewire positioned in the bodily vessel, the supplementary guidewire being positioned in the first lumen, and the first tubular member having a directing means to direct the supplementary guidewire passing through the first lumen in the transverse direction.

In one embodiment of the fourth aspect, a supplementary catheter can be positioned over the supplementary guidewire in the first lumen. The supplementary catheter can have a distal steerable end, an end portion that has a preformed angle, or can normally assume a curved configuration. In another embodiment, the supplementary catheter can have the features of the intraluminal catheter according to the first, second or third aspects of the present invention.

According to a further aspect, the present invention comprises a method for directing a supplementary guidewire in a direction transverse to the locus of a main guidewire positioned in a bodily vessel, comprising the steps of:

- (a) positioning the main guidewire in the bodily vessel;
- (b) guiding the support means of the intraluminal catheter as defined herein over the main guidewire and into the bodily vessel;
- (c) passing the supplementary guidewire through the first lumen of the intraluminal catheter so that it is directed by the directing means in the transverse direction into the bodily vessel.

In a preferred embodiment of this aspect, a supplementary catheter is firstly passed through the first lumen so that it is directed in the transverse direction and the supplementary guidewire is then passed through the supplementary catheter. The supplementary guidewire is preferably directed into a vessel branching off the bodily vessel.

#### Brief Description of the Drawings

Hereinafter by way of example only, preferred embodiments of the invention are described with reference to the accompanying drawings, in which:

Fig. 1 is a diagrammatic representation of a ventral view of a patient having an aortic aneurysm bridged by a trouser graft;

Figs. 2a - i show the stages of carrying out a method of intraluminally placing a trouser graft into a patient which in part uses the invention defined herein;

Fig. 3 is a side elevational view of the end portion of one embodiment of an intraluminal catheter according to the present invention;

Fig. 4 is a cross-sectional view of the end portion of Figure 3;

Fig. 5 is a side elevational view of the end portion of a second embodiment of an intraluminal catheter according to the present invention;

Fig. 6 is a further view of the end portion of Figure 5 with the sleeve retracted relative to the end portion;

Fig. 7 is a cross-sectional view of the end portion depicted in Figure 6;

Fig. 8 is a cross-sectional view of the end portion of a third embodiment of a intraluminal catheter according to the present invention;

Fig. 9 is a vertical sectional view of one embodiment of a possible bifurcated graft mounted over a delivery catheter for use in the method depicted in Figs. 2a - i; and

Fig. 10 is a vertical sectional view of one embodiment of a tubular graft mounted over a delivery catheter for use in the method depicted in Figs. 2a - i.

#### Preferred Mode of Carrying out the Invention

The present invention can be used in any surgical procedure where it is necessary to direct a guidewire into a bodily vessel whether it be for the placement of an intraluminal graft or another surgical procedure. Examples



of vessels in which it can be necessary to direct a guidewire include the aorta, the renal and the iliac arteries.

The present invention is hereinafter described with reference to the example of the placement of an intraluminal graft into a patient to achieve bridging and occlusion of an aortic aneurysm. Other examples of where the present invention will have application will be readily apparent to persons skilled in the art.

As is seen in Figure 1, the aorta 10 branches into the right and left iliac arteries 12,13. The aortic aneurysm 14 is located between the renal arteries 15,16 and extends down the left iliac artery 13. One means of bridging the aneurysm 14 is to use a trouser graft 17 which is provided with a bifurcation to form a pair of short tubular extensions 19,19a which are connected to tubular grafts 17a,17b which extend down the iliac arteries 12,13, respectively. One such trouser graft is described in Australian Patent Specification No AU-A-78035/94, the description of which is incorporated herein by reference.

The method for positioning an intraluminal graft will now be described with reference to Figures 2a-i. In carrying out the method an incision is made to expose one of the femoral arteries (ipsilateral), which flows from the corresponding iliac artery, and using the Seldinger needle technique, a 0.035" diameter floppy tipped flexible guidewire is inserted into and through the femoral artery and then the iliac artery 12 into the aorta 10 such that it traverses the aneurysm 14. An 8 French haemostatic sheath is then introduced over the wire to control bleeding. An angiographic catheter is then introduced to allow an angiogram to be taken of the patient to show the position of the renal arteries 15,16 and other relevant anatomical structures in the patient.

An Amplatz extra stiff AES guidewire 23 (0.035" diameter) is then passed through the angiographic catheter into the aorta 10. After withdrawal of the angiographic catheter, the stiff guidewire 23 is left *in situ*. A sheath 21, preferably of 18 French, is then introduced into the aorta 10 over the stiff guidewire 23 (see Figure 2a). A balloon catheter 24 is then introduced into the sheath 21 over the stiff guidewire 23.

As is seen in Fig. 9, the balloon catheter 24 is pre-packaged with a bifurcated graft 17, having a bifurcation point 17c, an ipsilateral extension 19, and a contralateral extension 19a. As is seen in more detail in Figs. 3 and

4, the catheter 24 has a first elongate tubular member 52 and a second elongate tubular member 51 that is adapted to pass over the stiff guidewire 23 and support the catheter 24 within the intraluminal graft 17. Disposed within the first tubular member 51 is a supplementary guidewire 26  
5 surrounded by a thin supplementary catheter sheath 26a that extends in a first direction up the ipsilateral extension 19, with the end 55 of the first tubular member 52 being disposed just above the bifurcation point 17c.

When the balloon catheter 24 is positioned within the aorta 10 correctly, the sheath 21 is partially withdrawn to free the graft 17 so that the  
10 balloon 20 may be inflated (see Figure 2b). The inflation of the balloon 20 expands the upstream end of the first graft 17 and causes it to engage its upstream end against the aorta wall above the aneurysm 14 but downstream of the renal arteries 15,16. The first graft 17 is of such a length that the short tubular extensions 19,19a are disposed wholly within the aorta 10. The  
15 balloon 20 is then deflated but the balloon catheter 24 is left in place for the time being (see Figure 2c). Deflation of the balloon 20 allows blood to flow down and distend the graft 17 and the tubular extensions 19,19a.

Once the first graft 17 is in place, it is necessary to extend the guidewire 26 down the left iliac artery 13. In the depicted example, this is  
20 achieved by guiding the supplementary catheter 26a through the lumen of the first tubular member 52 such that it strikes the angled surface 54 and is deflected laterally out of the locus of the first tubular member 52 and through the aperture 50 in the first tubular member opposite the angled surface 54. The region of the catheter 26a proximate its tip can normally assume an  
25 angle or curved configuration relative to the normally straight configuration of the remainder of the catheter 26a.

The catheter 26a can be deployed through the aperture 50 as desired by the physician. The guidewire 26 can then be guided through the catheter 26a and into the left iliac artery 13 as is depicted in Fig. 2c. As is depicted in  
30 Figure 4, the catheter 24 can also have an inflatable balloon 100 proximate the end 55 of the first tubular member 52. The balloon 100 can be inflated once the catheter 24 is in place to further hold the catheter 24 in the appropriate position and block the right iliac artery 12 so ensuring blood flow is directed down the left iliac artery 13 as the guidewire 26 is being guided  
35 through the left iliac artery 13.

Rather than normally assuming a curved or angled configuration proximate its tip, it can be readily envisaged that the catheter 26a could be modified from that depicted such that it has the features of the catheter 24 or the catheters 60 and 70 described in more detail below. For example, the catheter 26a could also have first and second elongate tubular members, with the second elongate tubular member disposed over the guidewire 26 and the first tubular member having directing means to direct a further guidewire passing therethrough in a desired direction. Such a catheter could be used in the present application where it is necessary to eventually direct a guidewire from the left iliac artery 13 into the corresponding left femoral artery.

Alternative embodiments of the intraluminal catheter according to the present invention are depicted in Figs. 5-8. One alternative is depicted generally as 60 in Figs. 5-7. The catheter 60 has a first elongate tubular portion 63 having a main portion 65 that normally assumes a relatively straight configuration and an end portion 66 (fabricated from a shape memory material) that normally assumes a curved configuration. While the end portion 66 is depicted as normally assuming a curved configuration, it can be readily envisaged that the end portion 66 could be preformed with an angle if this more suited the application of the catheter 60. The catheter also has a second elongate tubular member 61 that acts as a support means for the catheter 60 by being able to be slid over a guidewire, such as the stiff guidewire 23 used in the depicted example at Figs. 2a-i. The catheter further has a sleeve 62 that is relatively movable along the catheter 60 between a first position where it surrounds the first and second tubular members 63,61 (such as is depicted in Fig. 5) and a second retracted position where the end portion 66 is free to assume its normal configuration (such as is depicted in Figs. 6 and 7). If used in the placement of an intraluminal graft such as is depicted by Figs. 2a-i, the graft 17 is packaged about the catheter 60 such that the end portion 66 is positioned just above the bifurcation 17c. Once the catheter 60 is in the desired position in the aorta 10, the graft 17 is deployed as described above. The sleeve 62 is then retracted relative to the end portion 66 thereby allowing the end portion 66 to assume its normal curved configuration. The guidewire 26 is then guided through the first tubular member such that it emerges from the end portion 66 in the desired direction into the left iliac artery 13.

While only the guidewire 26 is depicted being guided through the end portion 66 of the catheter 60 in Figs. 5-7, it can be readily envisaged that a supplementary catheter, such as the supplementary catheter 26a, could be used in association with the catheter 60 as was described in relation to catheter 24.

The catheter generally depicted as 70 in Fig. 8 has many of the features of the catheter 60 except that the orientation of the end portion 66 relative to the main portion 65 is controlled by a physician manipulating the control wire 71 which is secured to the end portion 66 and is fed back through a further lumen 72 in the catheter 70. As with the other depicted embodiments, the guidewire 26 on being guided through the end portion 66 is directed in a desired direction towards the left iliac artery 13.

The guidewire 26 is preferably comprised of a non-kinking nitinol alloy material. If desired, the guidewire 26 may have proximate its tip a flow impedance device such as, an inflatable balloon 74 (see Figure 2c) (which can be inflated by passing a fluid, such as air, down a lumen in the guidewire 26), which serves to help the guidewire 26 to be carried and directed by blood flow into the left iliac artery 13.

As described above, if necessary, a further catheter having the features of one of the embodiments of the invention described herein can be fed over the guidewire 26 to assist in the placement of a further guidewire into another vessel branching off the left iliac artery 13.

One advantage of the present invention, apart from it providing better control over the placement of a guidewire into a vessel, is that the catheter when positioned in a vessel over the main guidewire 23 provides appropriate support for the supplementary guidewire 26 as it is guided through the catheter and directed into the branching vessel.

Once the guidewire 26 is correctly placed in the left femoral artery, a cutdown can be effected to that femoral artery which is cross-clamped and an arteriotomy effected. If the guidewire 26 has been guided fully into the contralateral femoral artery, the guidewire 26 is simply recovered by drawing the guidewire 26 through the incision or puncture made in the artery. If the guidewire 26 has not been guided fully along the femoral artery, a snare or similar device can be introduced through the contralateral femoral artery to grab the guidewire 26 and draw it back to the puncture or incision site for retrieval. Once the guidewire 26 is retrieved, a catheter 27 is then fed

through the contralateral femoral artery up the guidewire 26 until it is within the first graft 17 and reaches at least the top of the contralateral tubular extension 19a. The guidewire 26 is then withdrawn and a stiffer guidewire 30 inserted through the contralateral femoral artery into the catheter 27. The catheter 27 is then removed and a catheter sheath 21a, and dilator are introduced over the stiff guidewire 30 (see Figure 2e).

A second balloon catheter 24a, such as is depicted in Fig. 10, on which is packaged a second tubular graft 17b is then introduced through catheter sheath 21a until its upper end is well within the contralateral tubular extension 19a at its upper end and within the left iliac artery 13 at its lower end. The balloon 20a on the catheter 24a is inflated such that the upper end of graft 17b is frictionally engaged with the contralateral tubular extension 19a (see Figure 2f). The inflation of the balloon 20a on the catheter 24a supports the graft 17 during the withdrawal of the first balloon catheter 24 through the right iliac artery 12. The balloon 20a is then deflated and the catheter 24a maintained in place to provide continued support for the grafts 17, 17b in the aorta 10 while the third graft 17a is positioned.

The catheter sheath 21a is then removed (see Figures 2f and 2g) and a third balloon catheter, on which is packaged a tubular graft 17a, (the third balloon catheter can be identical to that depicted in Fig. 10) is introduced into the sheath 21 on guidewire 23. It is advanced until its upstream end is within the ipsilateral extension 19 and, following partial withdrawal of the sheath 21, is then deployed. A third graft 17a positioned on the third balloon catheter is thus urged at its upstream end into contact with the ipsilateral extension 19 and its downstream end into contact with the right iliac artery 12 (see Figure 2h).

The stiff guidewires 23 and 30 are now withdrawn and the contralateral incision or puncture sutured. A second angiographic examination now takes place and if the grafts 17, 17a and 17b are correctly placed and functioning, the haemostatic sheath 21 is withdrawn and the right femoral incision sutured (see Figure 2i). The result is a functioning trouser graft bridging an aneurysm as is depicted in Fig. 2i.

The operation may be carried out using a general anaesthetic, an epidural anaesthetic, or in suitable cases, using only a local anaesthetic.

It will be appreciated by persons skilled in the art that numerous variations and/or modifications may be made to the invention as shown in the specific embodiments without departing from the spirit or scope of the invention as broadly described. The present embodiments are, therefore, to  
5 be considered in all respects as illustrative and not restrictive.

## CLAIMS:

1. An intraluminal catheter for insertion through a bodily vessel, the catheter having a first elongate tubular member defining a first lumen, the tubular member having on its outer surface a support means adapted to slide  
5 over a main guidewire positioned in the vessel, the first elongate tubular member having directing means to direct a supplementary guidewire passing through the first lumen into the bodily vessel in a direction transverse to the locus of the main guidewire.
2. The catheter of claim 1 wherein the support means comprises a  
10 second elongate tubular member in side-by-side configuration with the first tubular member.
3. The catheter of claim 2 wherein the second tubular member is at least as long as the first elongate tubular member.
4. The catheter of any one of the preceding claims wherein the directing  
15 means comprises deflection means disposed on the catheter, the deflection means including a surface angled to the locus of the first lumen or an extension thereof such that the supplementary guidewire on passing through the first lumen will be deflected laterally out of the locus of the first lumen or the extension thereof.
- 20 5. The catheter of claim 4 wherein the angled surface is positioned within the first lumen and the first tubular member has an aperture opposite the angled surface such that the supplementary catheter on passing through the first lumen is deflected by the angled surface through the aperture.
6. The catheter of claims 4 or 5 wherein the angled surface is proximate  
25 a free end of the first tubular member.
7. The catheter of any one of claims 1 to 3 wherein the first tubular member has a main portion and the directing means comprises an end portion of the tubular member that is deflectable relative to the locus of the main portion.
- 30 8. The catheter of claim 7 wherein a control wire extends along the catheter and is secured to the end portion, retraction of the control wire relative to the catheter deflecting the end portion relative to the locus of the main portion.
9. The catheter of claim 8 wherein the control wire is disposed within a  
35 further lumen of the catheter.

10. The catheter of claim 7 wherein the main portion normally assumes a straight configuration and the end portion normally assumes a curved configuration, the catheter further having a sleeve that is relatively movable longitudinally with respect to the first tubular member between a first  
5 position where the sleeve surrounds the end portion and so straightens the end portion and a second retracted position where the end portion is free to assume its normal curved configuration.

11. The catheter of claim 7 wherein the main portion normally assumes a straight configuration and the end portion is preformed at an angle to the  
10 main portion, the catheter further having a sleeve that is relatively movable longitudinally with respect to the first tubular member between a first position where the sleeve surrounds the end portion and so straightens the end portion and a second retracted position where the end portion is free to assume its preformed angle to the main portion.

12. The catheter of any one of the preceding claims wherein the catheter  
15 can be introduced into the bodily vessel through an 18 French introducer sheath.

13. An intraluminal catheter for insertion through a bodily vessel, the catheter having a first elongate tubular member defining a first lumen, the  
20 tubular member having on its outer surface a support means adapted to slide over a main guidewire positioned in the vessel, the first tubular member having deflection means disposed on the catheter, the deflection means including a surface angled to the locus of the first lumen or an extension thereof such that a supplementary guidewire passing through the first lumen  
25 will be directed laterally out of the locus of the first lumen or the extension thereof.

14. The catheter of claim 13 wherein the deflection means is positioned within the first lumen and the first tubular member has an aperture opposite the angled surface such that the supplementary catheter on passing through  
30 the first lumen is deflected by the angled surface through the aperture.

15. An intraluminal catheter for insertion through a bodily vessel, the catheter having a first elongate tubular member defining a first lumen, the tubular member having on its outer surface a support means adapted to slide over a main guidewire positioned in the vessel, the first elongate tubular  
35 member having a main portion and an end portion wherein the main portion normally assumes a straight configuration and the end portion normally



assumes a curved configuration, the catheter further having a sleeve that is relatively movable longitudinally with respect to the first tubular member between a first position where the sleeve surrounds the end portion and so straightens the end portion and a second retracted position where the end portion is free to assume its normal curved configuration.

5 16. A kit for directing a supplementary guidewire in a direction transverse to the locus of a main guidewire positioned in a bodily vessel, the kit comprising an intraluminal catheter having a first elongate tubular member having a first lumen, the tubular member having a support means on  
10 its outer surface adapted to slide over the main guidewire positioned in the bodily vessel, the supplementary guidewire being positioned in the first lumen, and the first tubular member having a directing means to direct the supplementary guidewire passing through the first lumen in the transverse direction.

15 17. The kit of claim 16 wherein a supplementary catheter is positioned over the supplementary guidewire in the first lumen.

18. The kit of claim 17 wherein the supplementary catheter has a distal steerable end.

20 19. The kit of claim 17 wherein the supplementary catheter has an end portion that has a preformed angle.

20. The kit of claim 17 wherein the supplementary catheter normally assumes a curved configuration.

21. The kit of claim 17 wherein the supplementary catheter is as defined in any one of claims 1 to 15.

25 22. A method for directing a supplementary guidewire in a direction transverse to the locus of a main guidewire positioned in a bodily vessel, comprising the steps of:

(a) positioning the main guidewire in the bodily vessel;

30 (b) guiding the support means of the intraluminal catheter as defined in any one of claims 1 to 15 over the main guidewire and into the bodily vessel;

(c) passing the supplementary guidewire through the first lumen of the intraluminal catheter so that it is directed by the directing means in the transverse direction into the bodily vessel.

35 23. The method of claim 22 wherein a supplementary catheter is firstly passed through the first lumen so that it is directed in the transverse

direction and the supplementary guidewire is then passed through the supplementary catheter.

24. The method of claims 22 or 23 wherein the supplementary guidewire is directed into a vessel branching off the bodily vessel.

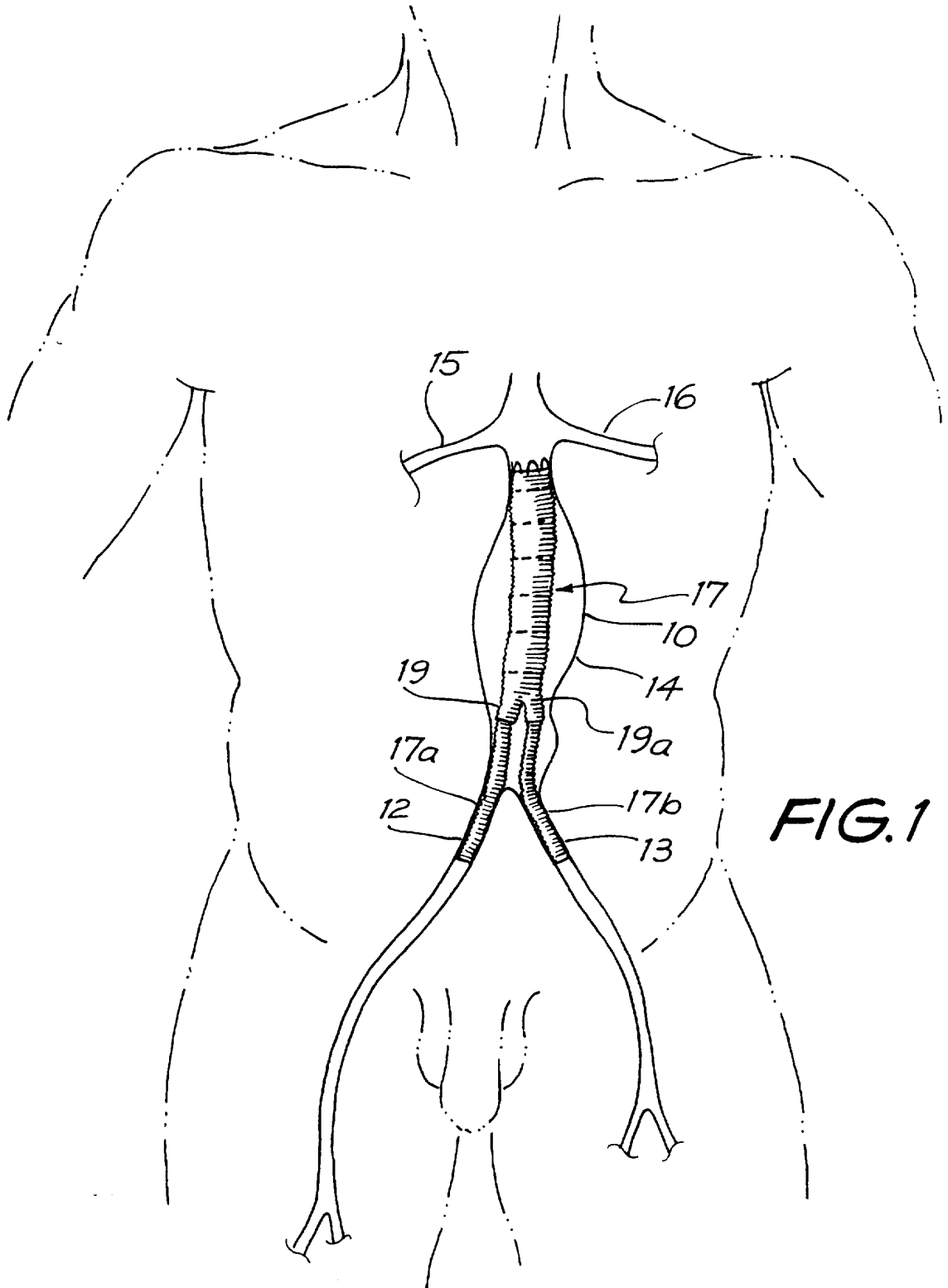

**FIG. 1**

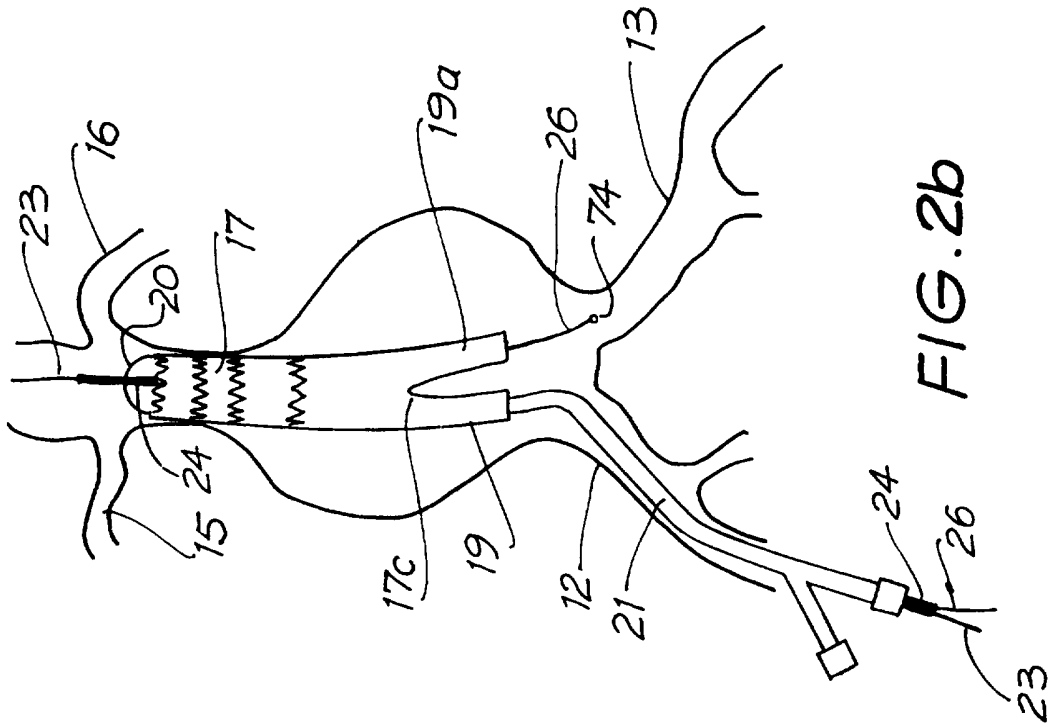

FIG. 2b

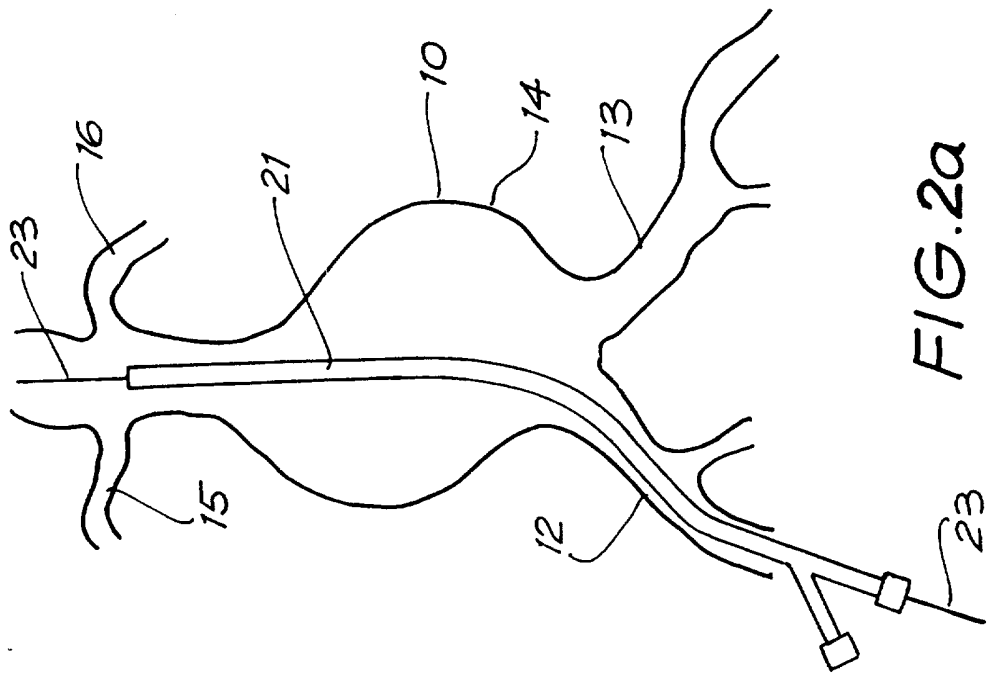

FIG. 2a

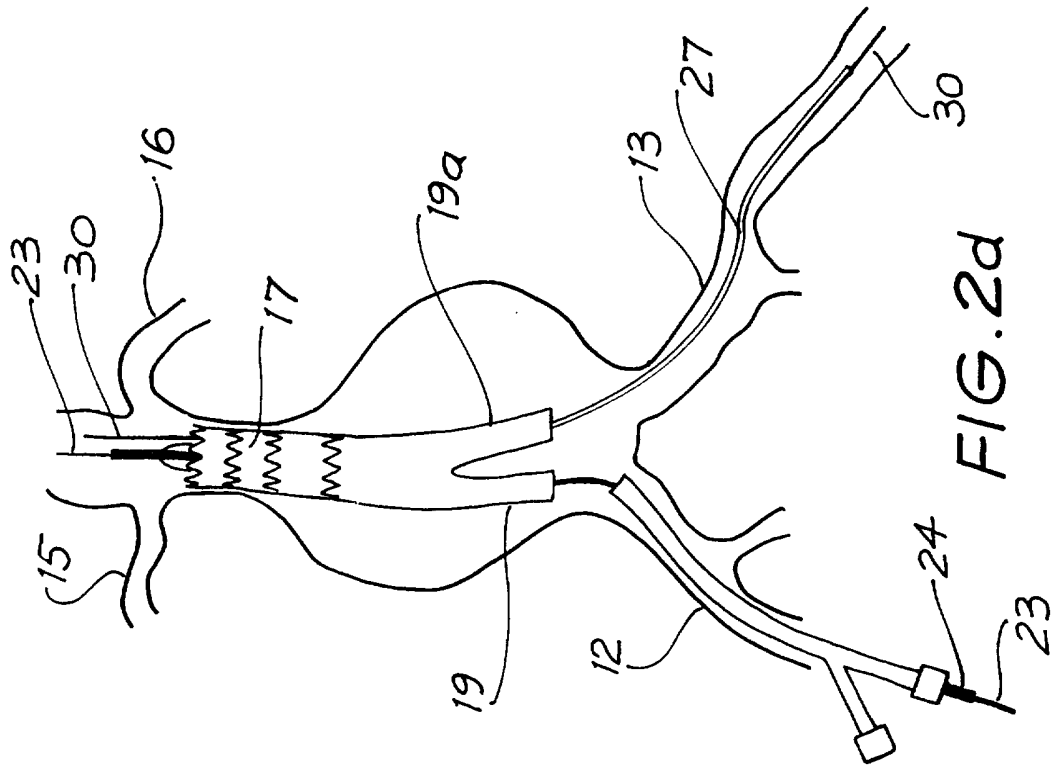

FIG. 2d

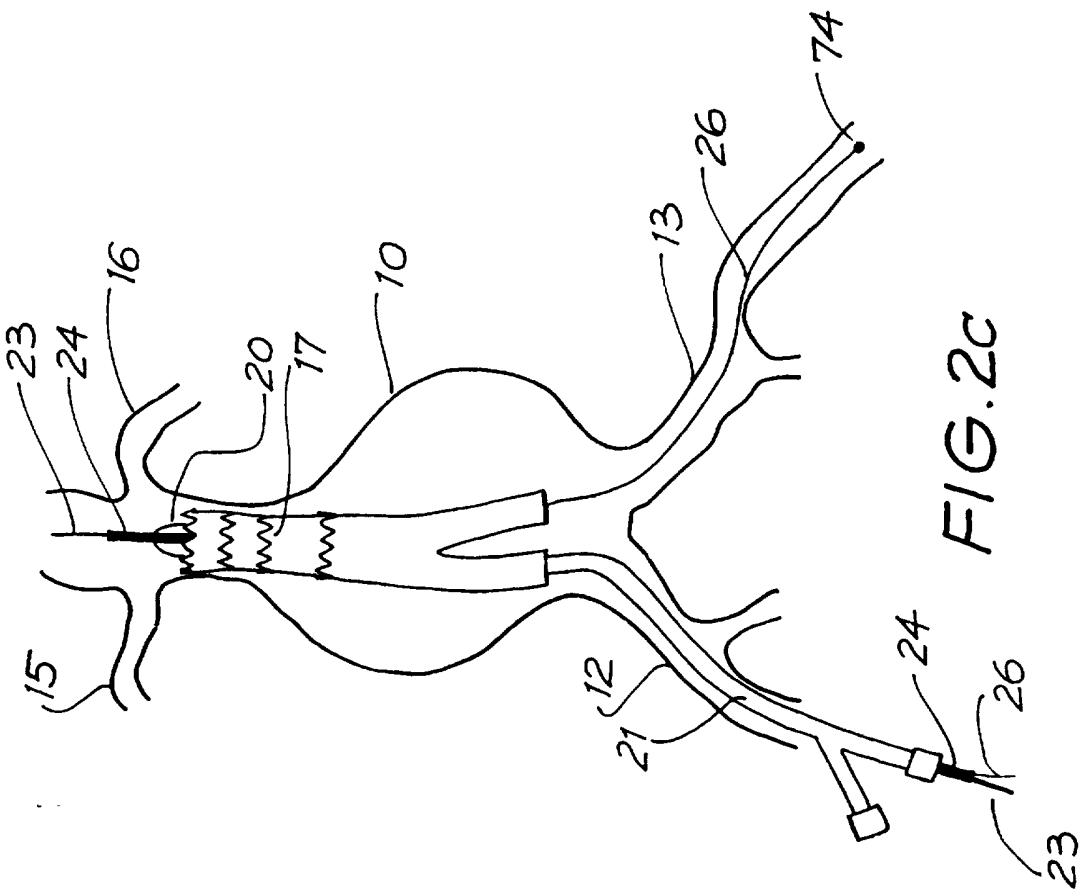

FIG. 2c

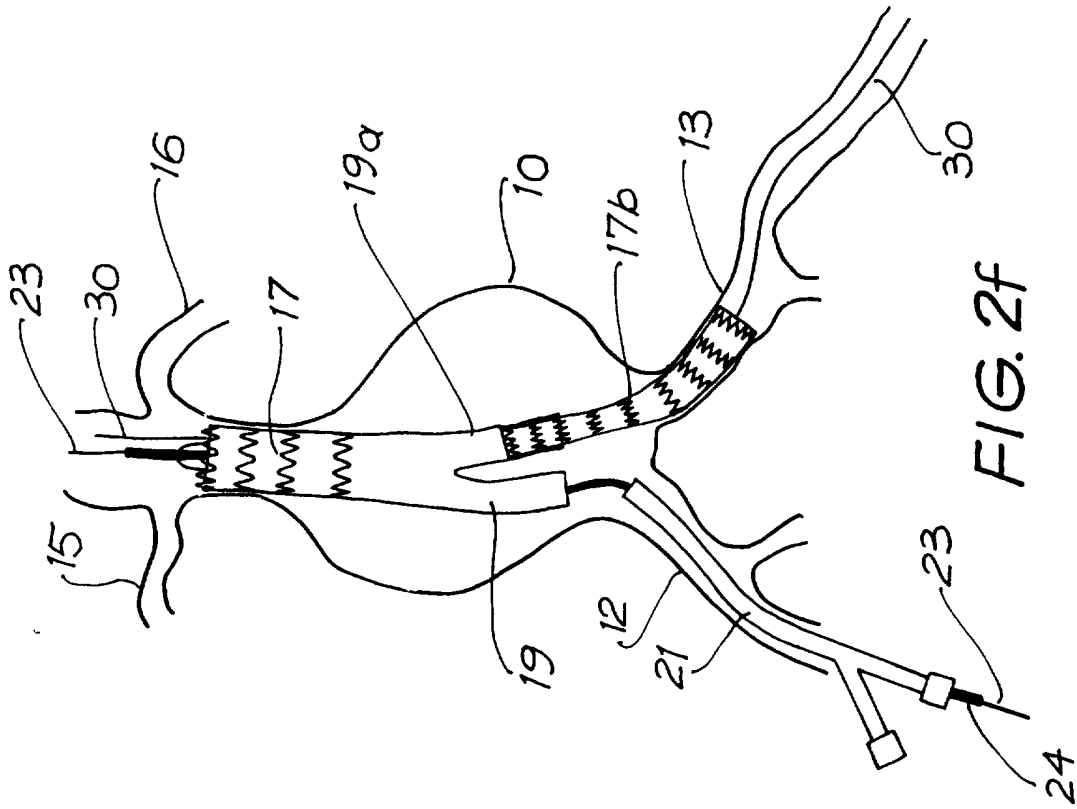

FIG. 2f

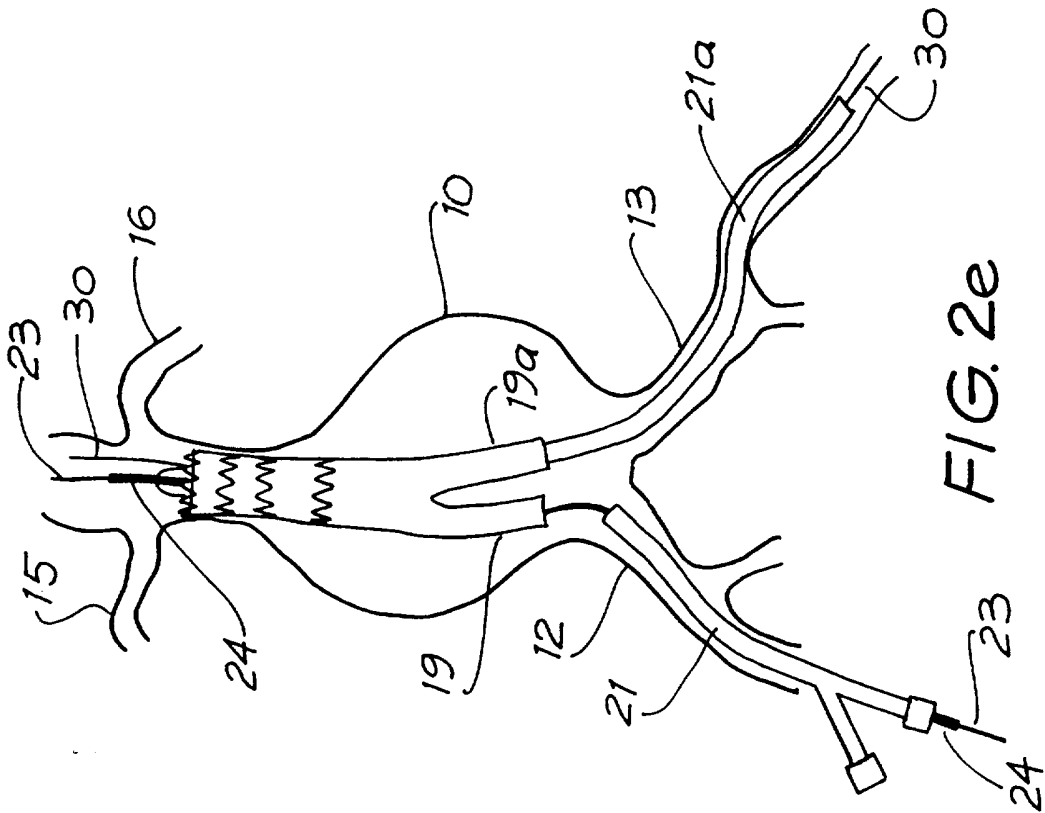

FIG. 2e

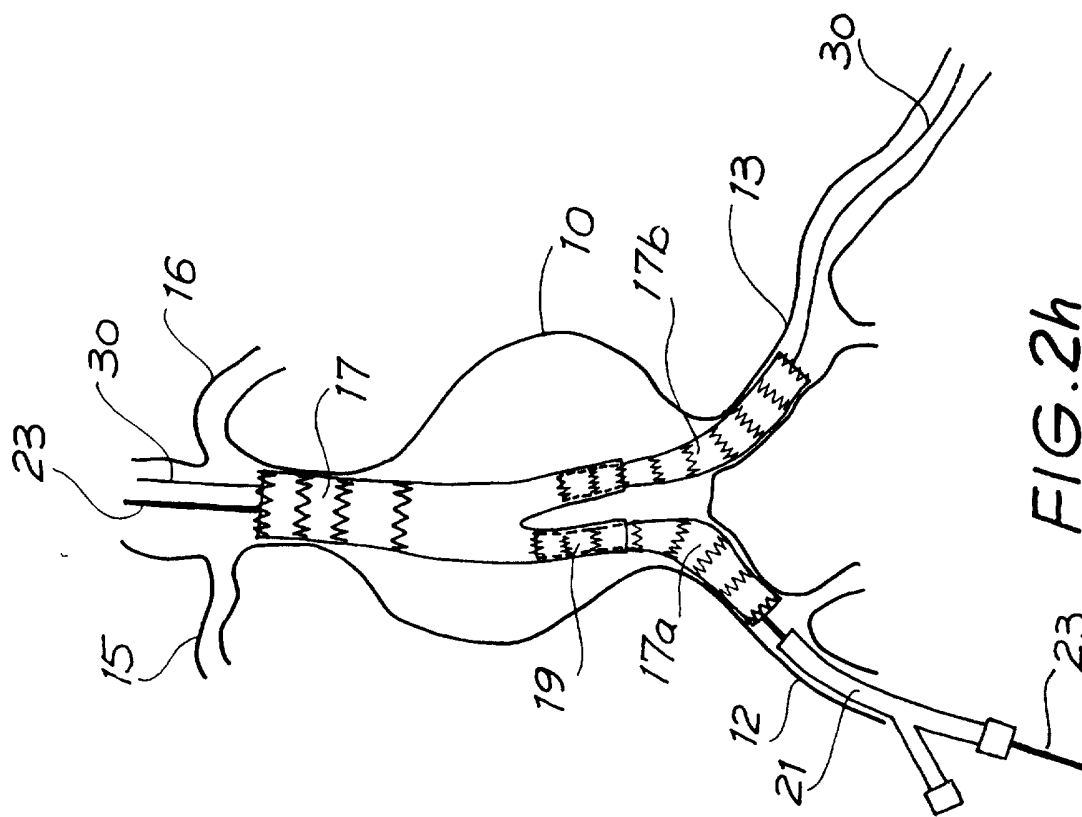

FIG. 2h

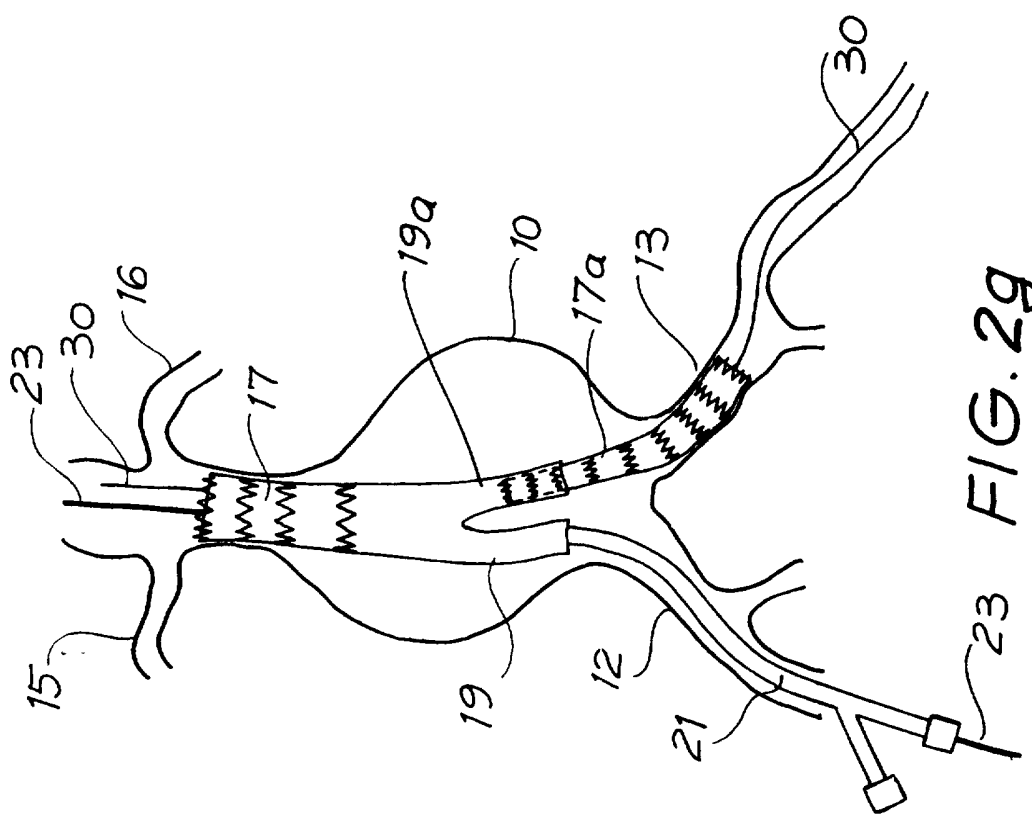

FIG. 2g

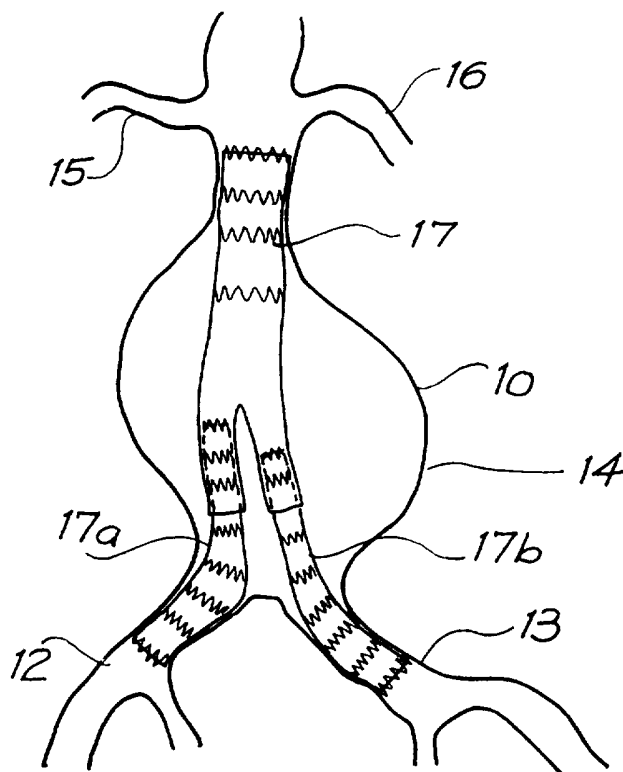

FIG. 2i



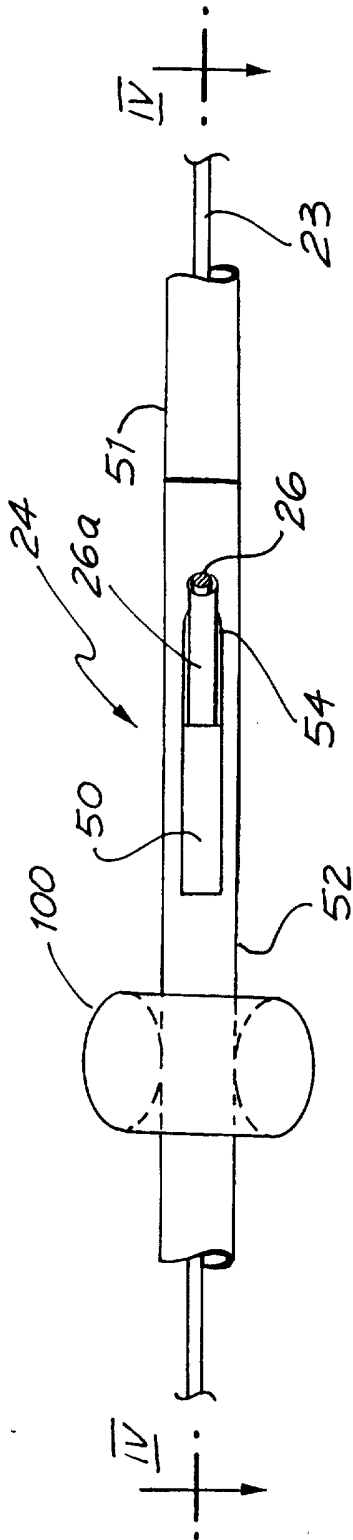

FIG. 3

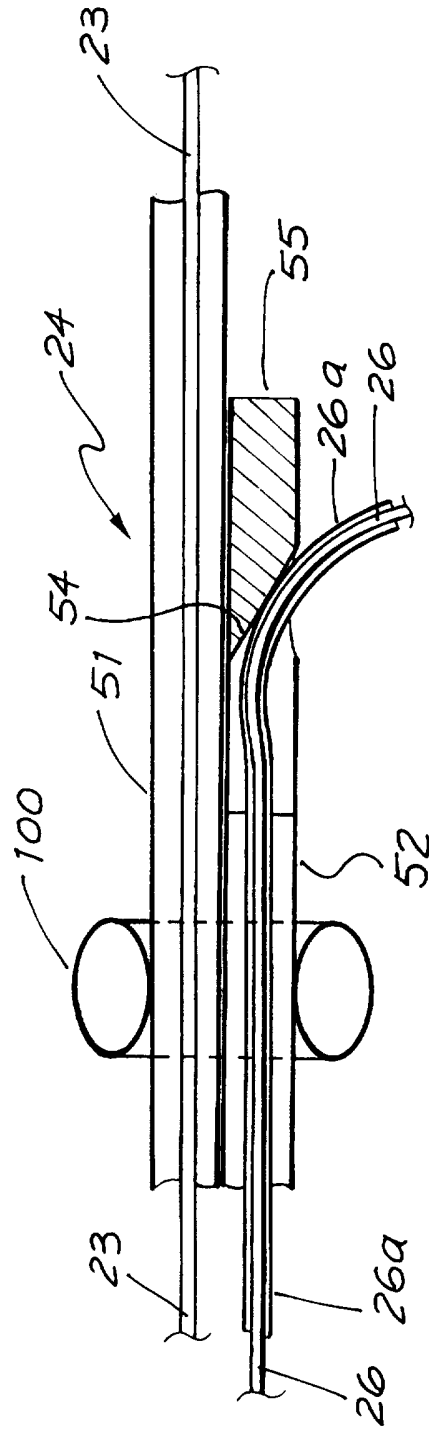

FIG. 4

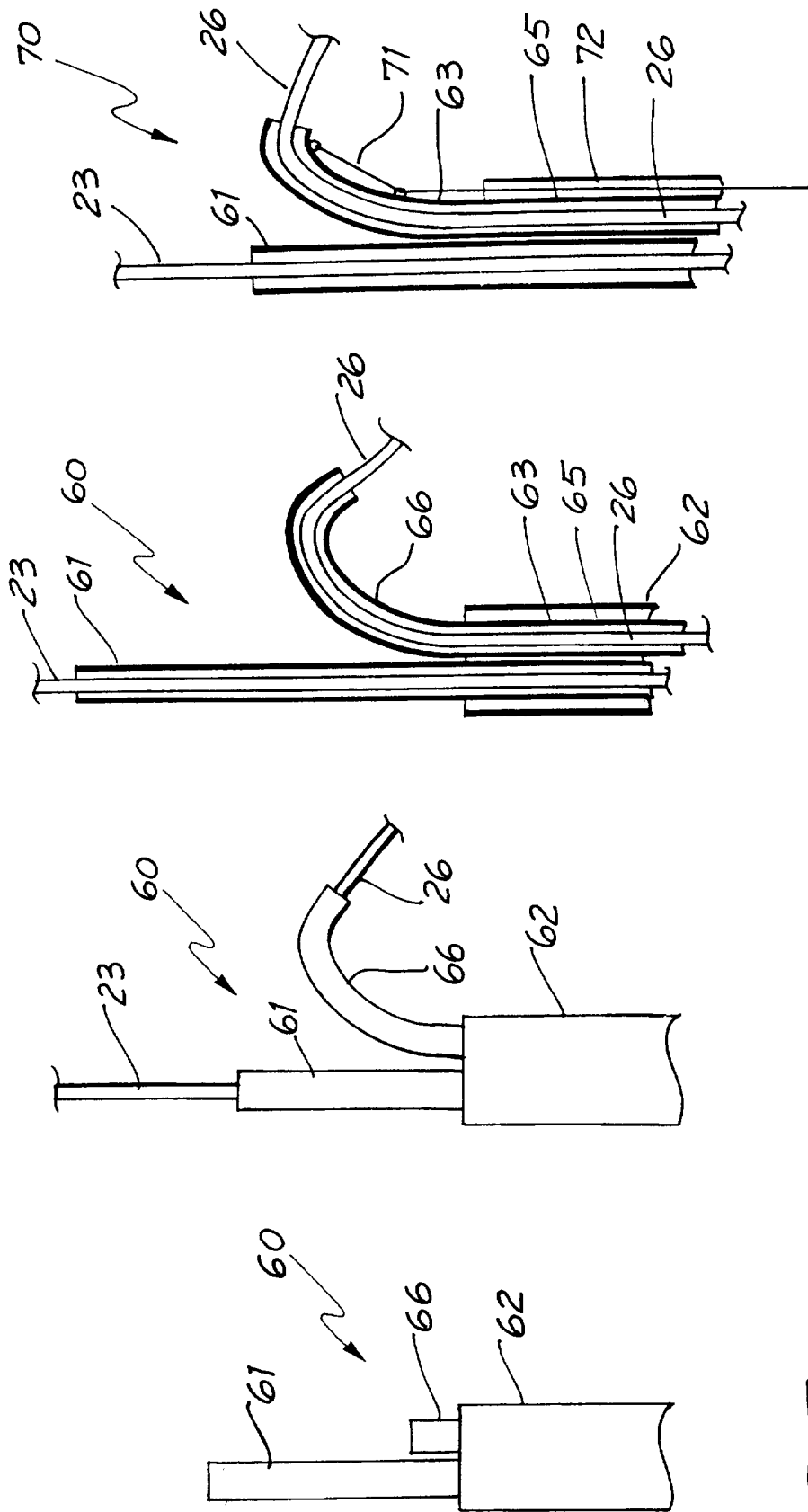
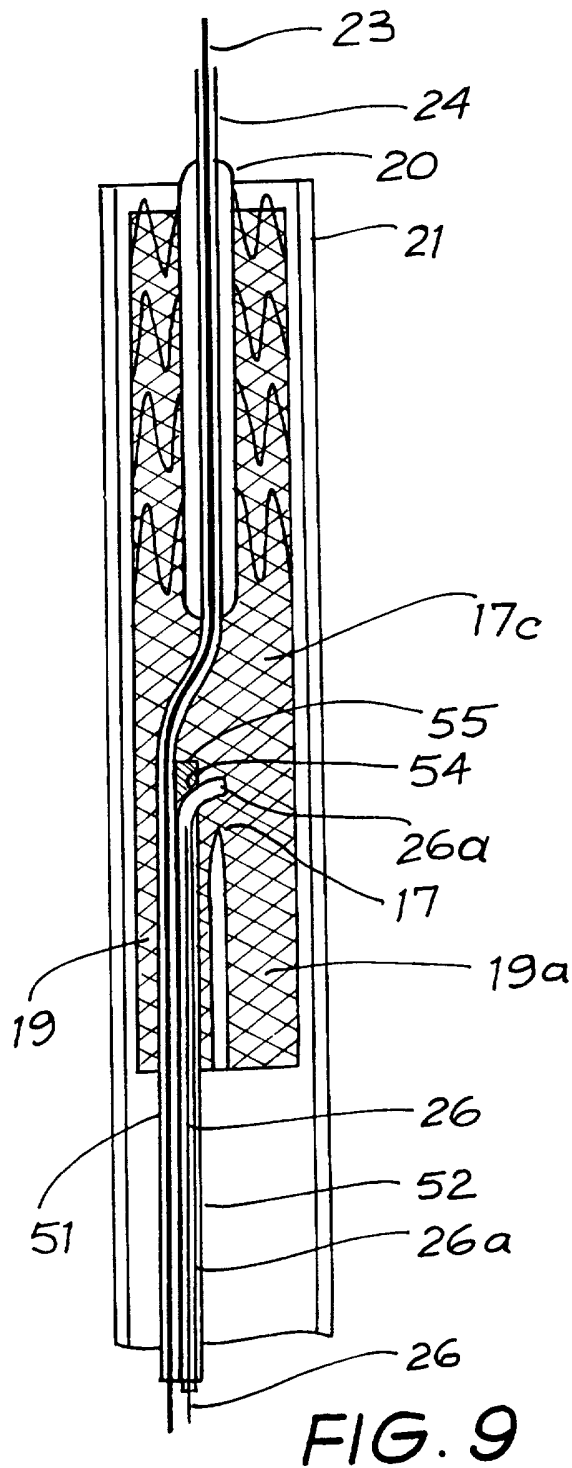

FIG. 8

FIG. 7

FIG. 6

FIG. 5



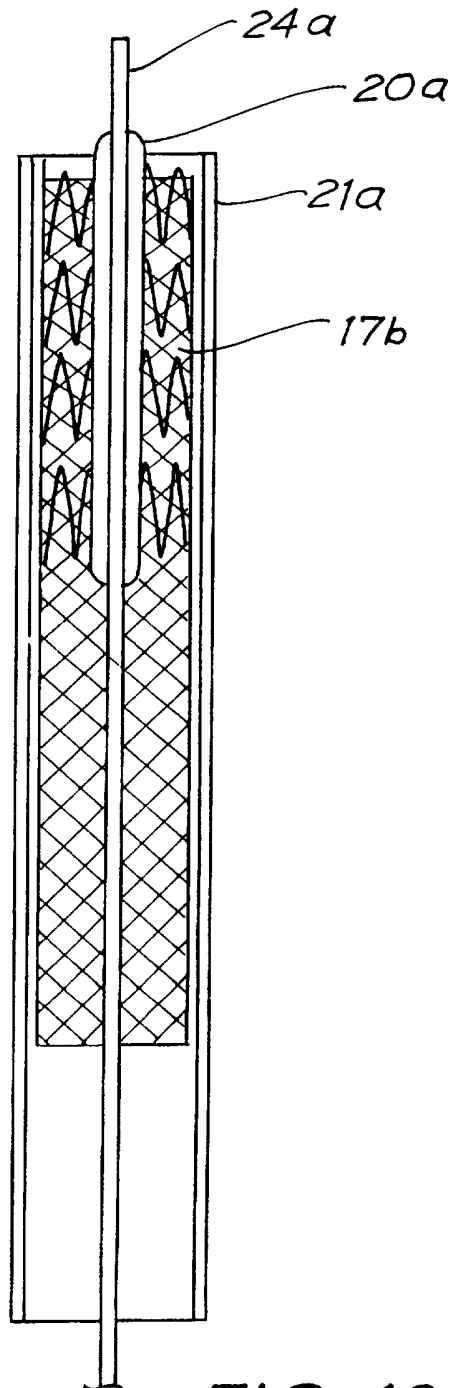

FIG. 10

# INTERNATIONAL SEARCH REPORT

International Application No.  
PCT/AU 97/00046

## A. CLASSIFICATION OF SUBJECT MATTER

Int Cl<sup>6</sup>: A61M 25/01 // A61M 25/09

According to International Patent Classification (IPC) or to both national classification and IPC

## B. FIELDS SEARCHED

Minimum documentation searched (classification system followed by classification symbols)  
A61M 25/00, 25/01, 25/09 ; A61F 1/-, 2/-, A61B

Documentation searched other than minimum documentation to the extent that such documents are included in the fields searched  
AU : IPC as above (1996 - 1975)

Electronic data base consulted during the international search (name of data base and, where practicable, search terms used)  
DERWENT. + (catheter: and guid: and (supplementary or second or two))

## C. DOCUMENTS CONSIDERED TO BE RELEVANT

Category*	Citation of document, with indication, where appropriate, of the relevant passages	Relevant to claim No.
X	AU 76144/94. A (BAVARIA MEDIZIN TECHNOLOGIE GmbH) 14 September 1995 see page 7. 2nd paragraph	1-6, 12-14, 16, 22-24
X	AU 53696/94. A (NEUGEBAUER-BUCHER) 9 May 1995 see page 6 lines 1- 22 and figures 1 and 2	1-6, 12-14, 16, 22-24
A	AU 73810/94. A (MED-PRO DESIGN, INC) 16 February 1995 whole document	1-24



Further documents are listed in the continuation of Box C



See patent family annex

* Special categories of cited documents:	"T" later document published after the international filing date or priority date and not in conflict with the application but cited to understand the principle or theory underlying the invention
"A" document defining the general state of the art which is not considered to be of particular relevance	"X" document of particular relevance; the claimed invention cannot be considered novel or cannot be considered to involve an inventive step when the document is taken alone
"E" earlier document but published on or after the international filing date	"Y" document of particular relevance; the claimed invention cannot be considered to involve an inventive step when the document is combined with one or more other such documents, such combination being obvious to a person skilled in the art
"L" document which may throw doubts on priority claim(s) or which is cited to establish the publication date of another citation or other special reason (as specified)	"&" document member of the same patent family
"O" document referring to an oral disclosure, use, exhibition or other means	
"P" document published prior to the international filing date but later than the priority date claimed	

Date of the actual completion of the international search  
4 March 1997

Date of mailing of the international search report

07.03.97

Name and mailing address of the ISA/AU  
AUSTRALIAN INDUSTRIAL PROPERTY ORGANISATION  
PO BOX 200  
WODEN ACT 2606  
AUSTRALIA Facsimile No.: (06) 285 3929

Authorized officer

D.R. LUM

Telephone No.: (06) 283 2544

# INTERNATIONAL SEARCH REPORT

International Application No.

PCT/AU 97/00046

C (Continuation) DOCUMENTS CONSIDERED TO BE RELEVANT		
Category*	Citation of document, with indication, where appropriate, of the relevant passages	Relevant to claim No.
A	US 4548597, A (NELSON) 22 October 1985 whole document	1-24
A	US 4552545, A (GOULD et al) 12 November 1985 whole document	1-24
X	US 4769005, A (GINSBURG et al) 6 September 1988 see column 3 line 61- column 4 line 31 and Figure 2	1, 2, 4-6, 12-14, 22-24
X	US 5059177, A ((TOWNE et al) 22 October 1991 see Figure 3	1-3, 16, 22-24
X	US 5413581, A (GOY) 9 May 1995 see Figure 5 and column 4 lines 50-64	1-6, 12-14, 16 22-24

**INTERNATIONAL SEARCH REPORT**

Information on patent family members

International Application No.

PCT/AU 97/00046

This Annex lists the known "A" publication level patent family members relating to the patent documents cited in the above-mentioned international search report. The Australian Patent Office is in no way liable for these particulars which are merely given for the purpose of information.

Patent Document Cited in Search Report		Patent Family Member					
AU	76144/94	WO	9524235	EP	738165	FI	963458
		NO	963659	CA	2184388	DE	4408108
		PL	316201	US	5419777		
AU	53696/94	WO	9408653	EP	689467	FI	951879
		JP	8504613	NO	951490	PL	308463
		SK	509/95	AT	134137	CA	2146989
		CZ	9500973	DE	4235506	ES	2083876
		HK	2133/96	HU	72681	US	5354279
AU	73810/94	CA	2168009	EP	713406	US	5395316
		WO	9504567				
US	4548597	AU	39163/85	CA	1229020	DK	1217/85
		EP	161045	JP	60210262	US	4548597
US	4552554	EP	166212	US	4552554		
US	4769005						
US	5059177						
US	5413581	AT	121303	EP	479730	ES	2071279
		JP	5137794				