

(19) **DANMARK**

(10) **DK/EP 2762047 T3**



Patent- og
Varemærkestyrelsen

(12) **Oversættelse af
europæisk patentskrift**

-
- (51) Int.Cl.: **A 47 K 3/40 (2006.01)** **E 04 F 19/06 (2006.01)**
- (45) Oversættelsen bekendtgjort den: **2017-03-20**
- (80) Dato for Den Europæiske Patentmyndigheds bekendtgørelse om meddelelse af patentet: **2016-12-14**
- (86) Europæisk ansøgning nr.: **14152980.0**
- (86) Europæisk indleveringsdag: **2014-01-29**
- (87) Den europæiske ansøgnings publiceringsdag: **2014-08-06**
- (30) Prioritet: **2013-02-01 DE 102013101018**
- (84) Designerede stater: **AL AT BE BG CH CY CZ DE DK EE ES FI FR GB GR HR HU IE IS IT LI LT LU LV MC MK MT NL NO PL PT RO RS SE SI SK SM TR**
- (73) Patenthaver: **ACO Severin Ahlmann GmbH & Co. KG, Am Ahlmannkai, 24782 Büdelsdorf, Tyskland**
- (72) Opfinder: **Smieja, Rainer, Sturmstrasse 3, 36037 Fulda, Tyskland**
- (74) Fuldmægtig i Danmark: **PATRADE A/S, Fredens Torv 3A, 8000 Århus C, Danmark**
- (54) Benævnelse: **Brusekabine-gulvelement.**
- (56) Fremdragne publikationer:
CA-C- 2 020 743
DE-B3-102006 047 437
DE-U1-202007 015 355

Shower base element**Description**

5 The invention relates to a shower base element for building a tiled bottom area according to the preamble to patent claim 1.

Shower trays which protrude above the tiled floor of a bathroom are previously disclosed for the installation of showers in bathrooms. For aesthetic reasons,
10 but also in order to reduce the risk of injury, showers are previously disclosed which no longer require a shower tray, in which the tiled floor of the bathroom in the shower area is in point of fact executed with a fall towards a drainage channel. The lateral transition of this gradient area into the horizontal tiled floor of the bathroom is capable of being produced only with considerable diffi-
15 culty.

In order to facilitate the manufacture of a suchlike level-access shower, a shower base element according to the preamble to claim 1 is previously disclosed in DE 20 2007 015 355 U1. A problem associated with this element,
20 which comprises a so-called gradient wedge, is both the stability and also the accuracy and the durability of the tiling consisting of the tiles of the bathroom floor in the area of the gradient wedge. Furthermore, in the case of the previously disclosed elements, it is not possible to build a shower wall without additional expenditure.

25 The invention has as its object to propose a shower base element of the kind referred to by way of introduction such that a level-access shower can be constructed with high stability and improved ease of installation.

30 This object is accomplished by a shower base element in claim 1.

In particular, this object is accomplished by a shower base element for building a tiled bottom area having a gradient in particular for a level-access shower, comprising a gradient wedge, the height of which increases in its longitudinal
35 direction, and which, on a first longitudinal side, exhibits a first stop surface for building a tiled floor and on its other, second longitudinal side, exhibits a second stop surface for laying the tiles of the bottom area having a gradient, in such a way that the first stop surface is realized, at least on a lower edge, in

order to constitute an undercut and a filling space with the tiles of the tiled floor installed.

5 An important aspect of the invention thus concerns the formation of the undercut or of the filling space, the result of which, on the one hand, is that the tile adhesive or the grout also ensures a connection of the gradient wedge to the tiles on the lateral edges of the tiles of the bathroom floor. In addition, this design ensures the increased stability of the gradient wedge itself.

10 According to the invention, the second stop surface merges via a horizontal visible surface into the first stop surface. A visually appealing solution is proposed as a result without the risk of injury.

15 The visible surface is realized according to the invention in such a way that a shower wall, in particular a glass shower wall, can be positioned on this horizontal visible surface and connected to it, e.g. adhesively bonded to it.

20 The first stop surface is preferably inclined with respect to a vertical direction in its entire height from the top to the bottom by a predefined angle of inclination in the direction of the second longitudinal side in order to form the filling space. Whereas strict parallelism of the two walls or stop surfaces is stipulated according to the above-mentioned publication in the prior art, the distance between the two stop surfaces reduces from the top (from the visible surface) to the bottom. As a result, on the one hand the aforementioned undercut or the filling space is formed in a simple manner, and on the other hand the gradient wedge thereby receives increased stability, in particular in relation to bending or torsional stiffness. The angle of inclination can be relatively small, where 80-88 degrees, in particular 84-86 degrees (e.g. 85 degrees), constitutes a preferred amount.

30 The lower edge of the first stop surface preferably merges into a support surface for laying tiles of the tiled floor. As a result, increased stability is achieved during the construction of the arrangement.

35 The support surface in this case is of preferably grid-shaped configuration with preferably regular recesses. This makes it possible, on the one hand, to bond the floor tiles firmly to the substrate (through the recess), and on the other

hand the gradient wedge is additionally secured firmly on the substrate by the tiles.

5 The gradient wedge is preferably formed from a (single) piece of a stainless material, a stainless steel sheet, from which the gradient wedge is bent, being particularly suitable for this purpose. The above-mentioned angling of the first stop surface with respect to the second longitudinal side for the purpose of forming the filling space in this case at the same time exhibits the advantage that a considerable increase is achieved in the strength of the connection or
10 the flexural strength of the gradient wedge.

The area between the two stop surfaces (beneath the horizontal visible surface) is preferably configured in such a way that filling with a setting material is possible.
15

The invention is described in more detail below on the basis of images of an illustrative embodiment. Here

20 fig. 1 depicts a frontal view of a gradient wedge,

fig. 2 depicts a perspective view of the gradient wedge according to fig. 1,

25 fig. 3 depicts an enlarged representation of the gradient wedge according to fig. 2, and

figs. 4a to 4k depict schematized representations of the process for building a shower floor using an inventive shower base element.

30 The same reference designations for identical parts and for parts with an identical effect are used in the following description.

In the illustrative embodiment represented here, a sheet of stainless steel is folded in the manner depicted in figs. 1-3. This results in a gradient wedge 10 having a support surface 24 (being horizontal after installation), which merges
35 via a lower edge 22 into a first stop surface 10. The first stop surface 20 in this illustrative embodiment exhibits an angle of less than 90 degrees, in particular about 85 degrees. The angle, which is designated by α in fig. 1, is thus about 5 degrees in relation to the vertical.

The first stop surface 20 merges into a visible surface 23, which runs parallel to the support surface 24 (and thus to the horizontal after installation).

- 5 The visible surface 23 then merges in turn into a second stop surface 21 running vertically downwards, which forms the second longitudinal side 12.

A cavity 13 is formed between the first longitudinal side 11 and the second longitudinal side 12 or between the two stop surfaces 20 and 21.

10

The second stop surface 21 in a top view (see the perspective representation according to fig. 2) is configured so that it becomes wider in its longitudinal direction (X), so that its lower edge 26 exhibits an increasing distance to the visible surface 23 from the start of the gradient wedge (in fig. 2, bottom left) to the end of the gradient wedge.

15

The support surface 24 exhibits recesses 25, which serve to secure the adhesive for the tiles to be laid firmly to the substrate and, by so doing, at the same time to secure the support surface 24 or the gradient wedge 2 firmly.

20

The installation of the gradient wedge 10 is described below on the basis of fig. 4.

- 25 The floor, which constitutes the substrate for tiles 1 of the tiled floor, is first provided with tile adhesive. A gradient wedge 10, of which the cavity 13 has already been filled with a setting material, is then put in position (Figs. 4b and 4c).

- 30 The tile adhesive is now applied over the support surface 24 and the rest of the floor (Fig. 4d), whereupon the tiles of the tiled floor are positioned tightly against the gradient wedge 10. The cavity formed by the slope of the first stop surface 20 in this case is filled with tile adhesive, so that the laid tiles can also be bonded to the gradient wedge 10 on their lateral edges.

- 35 After this process step (see fig. 4f), the tile adhesive is applied to the area which constitutes the tiled floor area having a gradient. After tiling (Fig. 4g), the edge between the gradient wedge 10 and the tiles of the bottom area hav-

ing a gradient 2 is filled with an elastic sealing compound. The shower area, as depicted in fig. 4j, is now finished.

5 If a shower wall 4 that is capable of being manufactured from glass, for example, is desired, this can now be positioned on the visible surface 23 using an intermediate and joint-filling adhesive (see fig. 4k).

10 It can be appreciated from the foregoing that an important aspect of the invention is that, on the one hand, the first longitudinal side 11 is realized opposite the second longitudinal side 12 of the gradient wedge when viewed downwards from the upper visible surface 23, thereby narrowing the cavity 13 formed between the two sides 11 and 12. The result of this, on the one hand, is a filling space for the introduction of tile adhesive, which also holds laid tiles of the tiled floor better on their lateral edges, and, on the other hand (in particular in conjunction with filling of the cavity 13), an increased bending strength and torsional strength of the element. At the same time, a visible surface 23 is formed, which is either left open, that is to say completely visible, or is used in addition for positioning a shower wall. The visible surface 23 is suitably prepared for this purpose on its surface, so that an adhesive can be applied for the connection of the gradient wedge 10 to the shower wall 4.

15
20

List of Reference Designations

1	25	1	tiled floor
2		2	tiled floor area having a gradient
3		3	drainage channel
30		4	shower wall
10		10	gradient wedge
11		11	first longitudinal side
35		12	second longitudinal side
13		13	cavity

	20	first stop surface
	21	second stop surface
5	22	lower edge
	23	visible surface
10	24	support surface
	25	recess
	26	lower edge of the second stop surface
15		

PATENTKRAV

1. Brusekabine-gulvelement til bygning af et flisebelagt gulvareal med hældning, og for en bruser i det væsentlige i samme niveau som gulvet, omfattende en hældningskile (10), hvis højde tiltager i kilens længderetning (X),
5 og som på en første langside (11) omfatter en første anslagsflade (20) med henblik på tilbygning af et flisegulv og på sin anden, anden langside (21) omfatter en anden anslagsflade (21) med henblik på lægning af bundområdetets fliser (2) med hældning,
k e n d e t e g n e t v e d , at den første anslagsflade (20) er udformet
10 på i det mindste en nedre kant (22), så der dannes en underskæring og et fyldrum, når det flisebelagte gulvs (1) fliser lægges, hvorved den anden anslagsflade (21) går over i den første anslagsflade (20) via en vandret, synlig overflade (23), og den vandrette, synlige overflade er udformet således, at en bruserumsvæg kan anbringes ovenpå.
15
2. Brusekabine-gulvelement ifølge krav 1,
k e n d e t e g n e t v e d , at brusekabinevæggen er udformet som en brusekabinevæg (4) af glas.
- 20 3. Brusekabine-gulvelement ifølge et hvilket som helst af de foregående krav,
k e n d e t e g n e t v e d , at den første anslagsflade (20) over hele sin højde fra øverst til nederst er skrånstillet i forhold til lodret retning, med en forudbestemt hældningsvinkel α , hen imod den anden langside (12) med henblik på dannelse af fyldrummet.
- 25 4. Brusekabine-gulvelement ifølge et hvilket som helst af de foregående krav, navnlig i forhold til krav 3,
k e n d e t e g n e t v e d , at hældningsvinklen (α) er 80 til 88 grader, navnlig 84 til 86 grader.
- 30 5. Brusekabine-gulvelement ifølge et hvilket som helst af de foregående krav,
k e n d e t e g n e t v e d , at den første anslagsflades (20) nedre kant (22) går over i en støtteflade (24) med henblik på lægning af flisegulvets (1) fliser ovenpå.
- 35 6. Brusekabine-gulvelement ifølge et hvilket som helst af de foregående krav,
k e n d e t e g n e t v e d , at støttefladen (24) er dannet som gitterformet med fortrinsvis regelmæssige udsparinger (25).

7. Brusekabine-gulvelement ifølge et hvilket som helst af de foregående krav, **k e n d e t e g n e t v e d**, at hædningskilen (10) er udformet af et (enkelt) stykke rustfrit materiale, navnlig bøjet og udstanset af en metalpladededel.

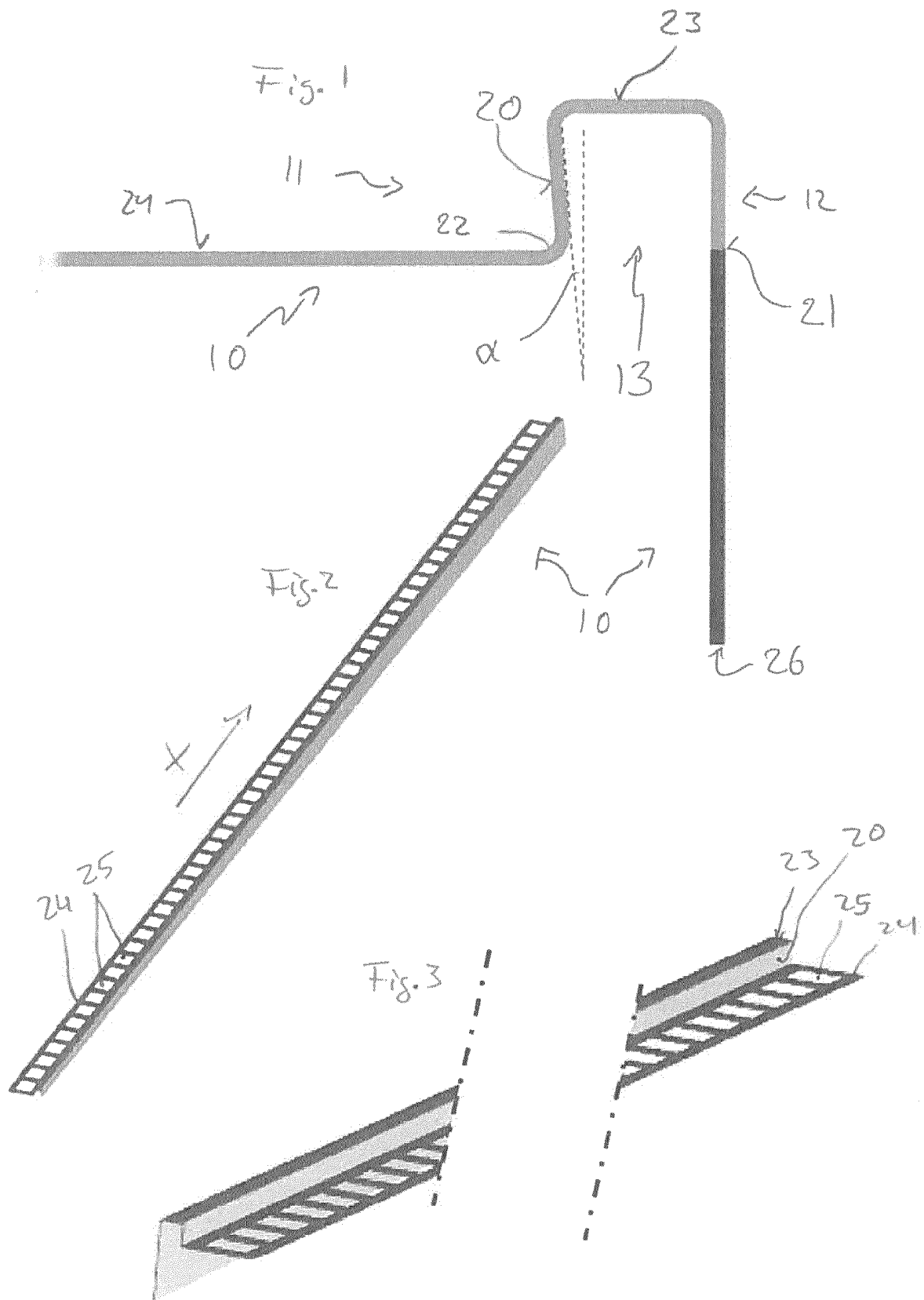

Fig 4

