



AFRICAN REGIONAL INDUSTRIAL PROPERTY  
ORGANISATION (ARIPO)

962

(11) (A)

<p>(21) <b>Application Number:</b> AP/P/97/01155</p> <p>(22) <b>Filing Date:</b> 19971124</p> <p>(24) <b>Date of Grant &amp;</b> 20010504 (45) <b>Publication</b></p> <hr/> <p>(30) <b>Priority Data</b></p> <p>(33) <b>Country:</b></p> <p>(31) <b>Number:</b></p> <p>(32) <b>Date:</b></p> <hr/> <p>(84) <b>Designated States:</b></p> <p style="padding-left: 20px;">BW GM GH KE LS MW</p> <p style="padding-left: 20px;">SD SZ UG ZM ZW</p>	<p>(73) <b>Applicant(s):</b> CONT-ASPHALT LIMITED 2<sup>nd</sup> Floor Allied Building Victoria/Mahe Seychelles</p> <p>(72) <b>Inventors:</b> Peter LEHMANN 121 Fifth Avenue Edenvale 1610 Republic Of South Africa (See Overleaf)</p> <p>(74) <b>Representative</b> HONEY &amp; BLANCKBERG P O BOX 85 HARARE ZIMBABWE</p>
---	--

(51) **International Patent Classification (Int.Cl.7):** B65D 88/74

(54) **Title:** Bitumen Container

(57) **Abstract:** THE INVENTION provides a heatable container for bitumen, cut-back or the like, comprising a body member 10 defining a base zone 10b, side wall zones 10c, end wall zones 10a and a roof zone 10d, characterized in means for transmitting heat from a heating medium to the base zone 10b and to at least part of the side wall zones 10c of the container.

**Inventors C0ntiunue**

Jacques GRISONI  
Route des Monts 410  
La Coix-Sur-Lutry  
Switzerland

---

**FIELD OF THE INVENTION**

**THIS** invention relates to a heatable container suitable for transporting and dispensing bitumen and cut-back compositions thereof.

**OBJECT OF THE INVENTION**

5 An object of the present invention is to provide a novel bitumen container which is capable of a certain degree of pressurisation and accordingly suitable for conveying cut-back compositions of bitumen or the like.

A further object of the invention is to provide a container with a heating facility whereby material in the container can be heated to a molten state for  
10 dispensing purposes.

A further object of the present invention is to provide a container suitable for bitumen or the like which is provided with a heating facility whereby a large contact area of the container will transmit heat to the bitumen to minimise degradation thereof.

**AP/P/ 97 / 01155**

SUMMARY OF THE INVENTION

According to the invention a container suitable for bitumen, cut-back or the like comprises a body member defining a base zone, side wall zones, end wall zones and a roof zone, characterized in means for transmitting heat from a heating medium to the base zone and to at least part of the side wall zones of the container. In one embodiment the means for transmitting heat from a heating medium will be adapted to transmit heat to the base zone, the side wall zones, and also to the roof zone of the container.

Further according to the invention the means for transmitting heat from the heating medium comprises a heating box or duct or the like disposed adjacent the base zone and at least part of the side wall zones of the container. In a preferred embodiment a heating box or duct for a heating medium will be constructed below the container base zone and extend at least partially up the side wall zones. Preferably also the heating box will include internal partitioning to define a pathway for heating medium to move from one or more burners to one or more chimney outlets along adjacent outward bound and return passages. Alternatively, the duct could be in the form of a plurality of pipe lengths disposed longitudinally about the periphery of the container, parallel to the longitudinal axis of the container, the pipe lengths being adapted

AP/P/97/01155

to duct heating medium therethrough, along a sinuous outward and return pathway.

It is a further feature of the invention that the container will be in the form of a tank structure with the base zone, side wall zones and roof zone defining a  
5 tubular structure of generally circular cross-section, and the end zones being domed outwardly.

Further according to the invention the tank structure will be mounted on supports within an ISO container frame. Preferably the domed ends of the tank will terminate short of the ends of the frame structure at one, or  
10 preferably both ends. It has been found that this feature will permit access to equipment such as burners disposed at the ends zones, even when the container is parked against a bulkhead or the like. Thus in one embodiment, one and preferably both ends will terminate approximately .05 metres short of the ends of the frame structure. With such an arrangement the diameter of the tank in  
15 cross-section will be approximately 2,300 metres.

AP/P/ 97 / 01155

DESCRIPTION OF DRAWINGS

In order more clearly to illustrate the invention an embodiment thereof is described hereunder purely by way of example with reference to the accompanying drawings wherein:

- 5 Figure 1 is a schematic perspective view of a bitumen and cut-back container in accordance with the invention;
- Figure 2 is a schematic sectioned elevation of the container in Figure 1;
- Figure 3 is a schematic sectioned end elevation on line III-III in Figure 1;
- 10 Figure 4 is a schematic sectioned plan on line IV-IV in Figure 3;
- Figure 5 is a schematic sectioned end elevation of a different embodiment to the container in Figure 1; and
- Figure 6 is a schematic sectioned end elevation of yet a different embodiment to the container in Figure 5.

AP/P/97/01155

DESCRIPTION OF A PREFERRED EMBODIMENT

Referring to the drawings container for bitumen, cut-back or the like comprises a pressure vessel in the form of a tank 10 having a elongated body of substantially circular cross-section which terminates at its ends in outwardly domed end sections 10a. It is a feature of the invention that the tank 10 should be capable of being pressurised for example for conveying a cut-back bitumen formulation, and the construction will accordingly be in accordance with ISO standard IMO-type II specifications.

The tank 10 described above will be mounted in a frame 11 which also complies with ISO specifications for containers in respect of dimensions, mounting means, etc. As shown in the drawings the tank 10 will be mounted on a pair of spaced cradle formations 12 and it will be noted that the domed ends 10a of the tank 10 structure terminates short of the ends of the frame 11. Preferably a space of approximately 0.5 metres will be left between the domed ends 10a and the end of the frame 11. This feature of the invention serves to provide access to equipment such as oil burners which are discussed in more detail below, in situations wherein the container frame 11 is stacked against an adjacent frame, bulkhead or the like.

Thus where the length of the frame structure is 6,058 metres, the length of the tank will preferably be in the order of 5,00 metres. In accordance with ISO standards, the height and width of the frame structure will be 2,591 metres and 2,438 metres respectfully.

5 It is a further feature of the invention that a facility is provided for heating material in the tank 10 and that heat transfer will take place along the bottom zone 10b of the tank 10 and also along at least part of the side walls 10c thereof. Thus in the embodiment illustrated in Figures 1 to 4, a heating box in the form of a structure 13 is provided below the tank 10 and extends up the  
10 side walls 10c thereof to substantially the widest point of the tank 10. It is envisaged that the interior of the heating box 13 will be heated either by means of one or more burners, not shown, which will be removably located in holders 14; or alternatively by means of a network of tubes 23 designed to carry a heating liquid such as oil. Preferably the interior of the heating box  
15 13 will be partitioned by means of vertical ribs 15 as shown in Figure 3 and Figure 4 so that hot combustion gasses from the burner holders 14 will follow a sinuous outward and adjacent return pathway 16, 17 respectively to a chimney outlet 18. It will be noted that in the arrangement in Figure 4, two opposed burner holders 14 and two opposed chimney outlets 18, are provided  
20 for efficient utilisation of heat. Preferably insulation in the form of an outer packing of mineral wool, glass fibre mat or the like 19, on the outer surface

of the tank 10 and the heating box 13 will be provided. A protective outer skin 20 of metal or plastics sheet material will enclose the insulation 19.

A different embodiment to the one described above is shown in Figure 5, wherein the heating box 13 extends around the entire side wall 10c of the container as well as the roof zone 10d thereof. The heating box thus extends  
5 around the entire container 10 and if required, could also extend over the end walls 10a of the container 10. With this arrangement, additional partitions 15 will preferably be provided at least at the zone of the widest portion of the tank 10, and as described above, the hot combustion gasses will be ducted to  
10 follow an outward and return pathway between the various partitions 15. With this arrangement, additional heat transfer area between the heating box 13 and the tank 15 is thus provided, to ensure efficient heat transfer and an overall gradual heat transfer process.

In Figure 6 yet a further variation of the invention is illustrated and in this  
15 arrangement the network of tubes 23 surrounds the tank 10 in a longitudinal direction. As stated above, the network of tubes 23 can be utilized as an alternative to hot combustion gasses for heating the tank 10. The tubes 23 could for example carry a heating liquid such as oil in a sinuous outward and return pathway or could be utilized for carrying a gaseous heating medium.

Preferably the tubes or pipes 23 will be disposed in contact with the tank 10 to transfer heat through conduction as well convection.

It has been found that the arrangement of the invention provides a large heat transfer area between the heating box 13 and the interior of the tank 10 which is advantageous from the point of view of efficient heat transfer. It has also been found that the degradation of material such as bitumen as a result of the heating is minimised by the large heat transfer area. In particular it has been found that a poor quality of bitumen can be successfully heated in the container of the invention to transform such bitumen to a sufficiently liquid state to be dispensed from a low level outlet shown at 21.

Doubtless variations in detail of the invention are possible without departing from the principles set out in the consistory clauses. For example, it will be appreciated that a suitable inlet to the container and access by way of a manhole or the like 22, can be provided as illustrated.

AP/P/97/01155

## CLAIMS

1. A container suitable for bitumen, cut-back or the like comprising a body member 10 defining a base zone 10b, side wall zones 10c, end wall zones 10a and a roof zone 10d, characterized by a heating box 13 for transmitting heat from a heating medium to the body member, the heating box 13 being in the nature of a shell extending over the base zone 10b, side wall zones 10c and the roof zone 10d spaced outwardly therefrom.
2. The container according to claim 1 wherein the heating box 13 includes internal partitioning 15 to define a pathway for a gaseous heating medium to duct the heating medium from the inlet 14 along a sinuous path 16, 17 to a chimney outlet 18.
3. The container according to claim 1 wherein the body member is in the form of a tank structure 10 with the base zone 10b, side wall zones 10c and roof zone 10d defining a tubular structure of a generally circular cross-section, and having end zones 10a, the tank structure 10 being mounted within a container frame 11, such that the ends 10a of the tank structure 10 terminate short of the ends of the frame structure 11 at one or both ends thereof, to permit access to the ends 10a of the container for the introduction of a heating medium to the heating box 13.
4. The container according to claim 3 wherein the ends 10a terminate 0.5 metres short of the ends of the frame structure 11, and the diameter of the tank structure is approximately 2.3 metres in cross-section and the length thereof is in the order of 5.00 metres.

AP/P/97/01155

5. The container according to claim 3 wherein the heating box 13 or duct 23 is constructed below the container base zone 10b and extends at least partially up the side wall zones 10c, and includes an inlet 14 for a gaseous heating medium and a chimney outlet 18 for the heating medium.
- 5
6. The container according to claim 5 wherein the heating box 13 includes internal partitioning 15 to define a pathway for the gaseous heating medium to duct the heating medium from the inlet 14 along a sinuous path to the chimney outlet 18.
- 10 7. The container according to claim 5 wherein the duct is in the form of a plurality of pipe lengths 23 disposed longitudinally about the periphery of the container 10, parallel to the longitudinal axis thereof, the pipe lengths 23 being coupled so as to duct heating medium therethrough along a sinuous pathway.
- 15 8. The container according to any one of claim 1 wherein the body member is in the form of a tank structure 10 with the base zone 10b, side wall zones 10c and roof zone 10d defining a tubular structure of generally circular cross-section, and the end zones 10a being domed outwardly.

9. The container according to claim 8 wherein the tank structure is mounted on supports 12 within an ISO container frame 11.
10. The container according to claim 9 wherein the domed ends 10a of the tank structure 10 terminates short of the ends of the frame structure 11 at one or both ends thereof, to permit access to the domed ends of the container for the introduction of a heating medium to the base zone 10b thereof.
11. The container according to claim 10 wherein the domed ends 10a terminate 0.05 metres short of the ends of the frame structure 11, and the diameter of the tank structure is approximately 2,3 metres in cross-section.

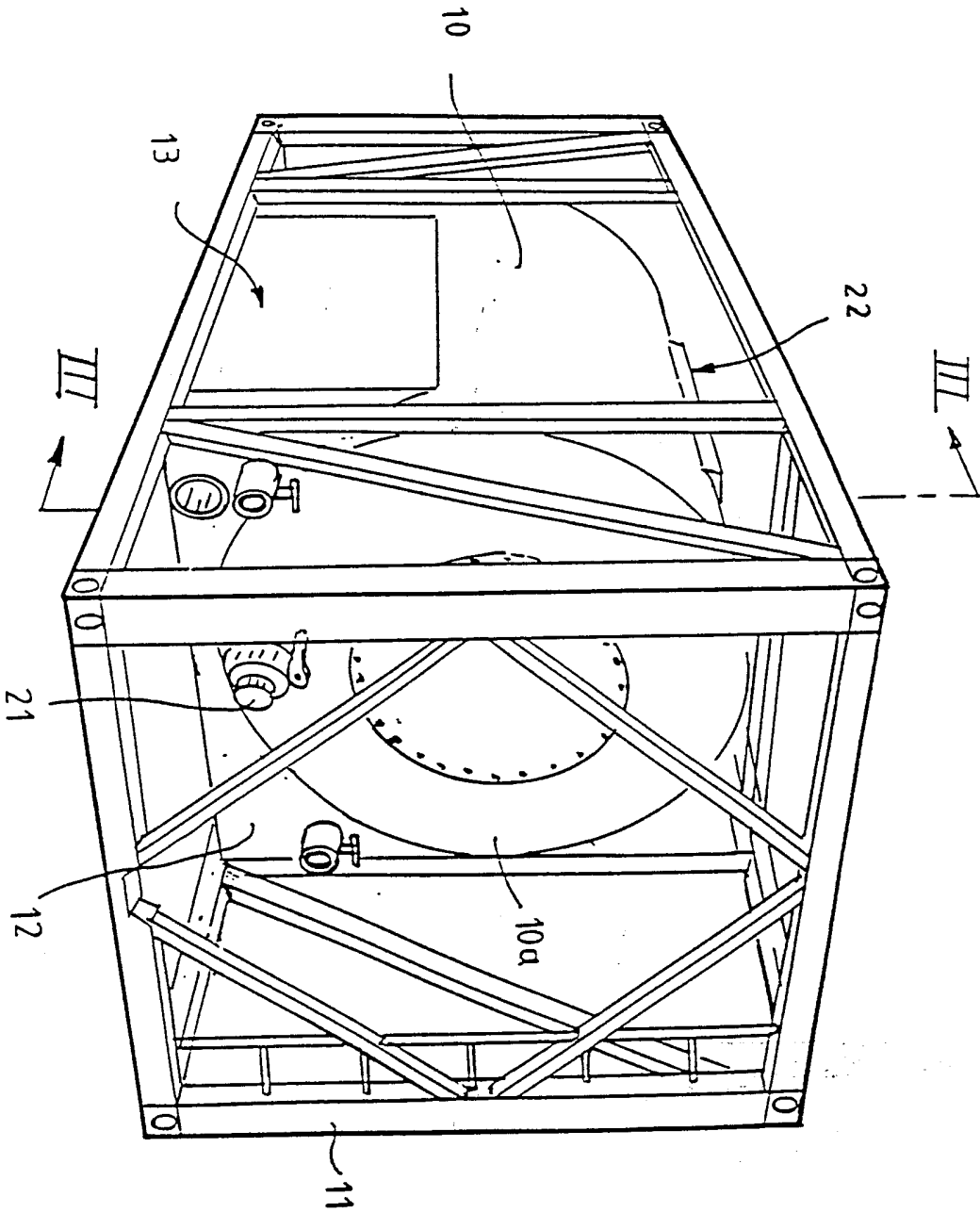

FIGURE 1

AP/P/ 97/0155

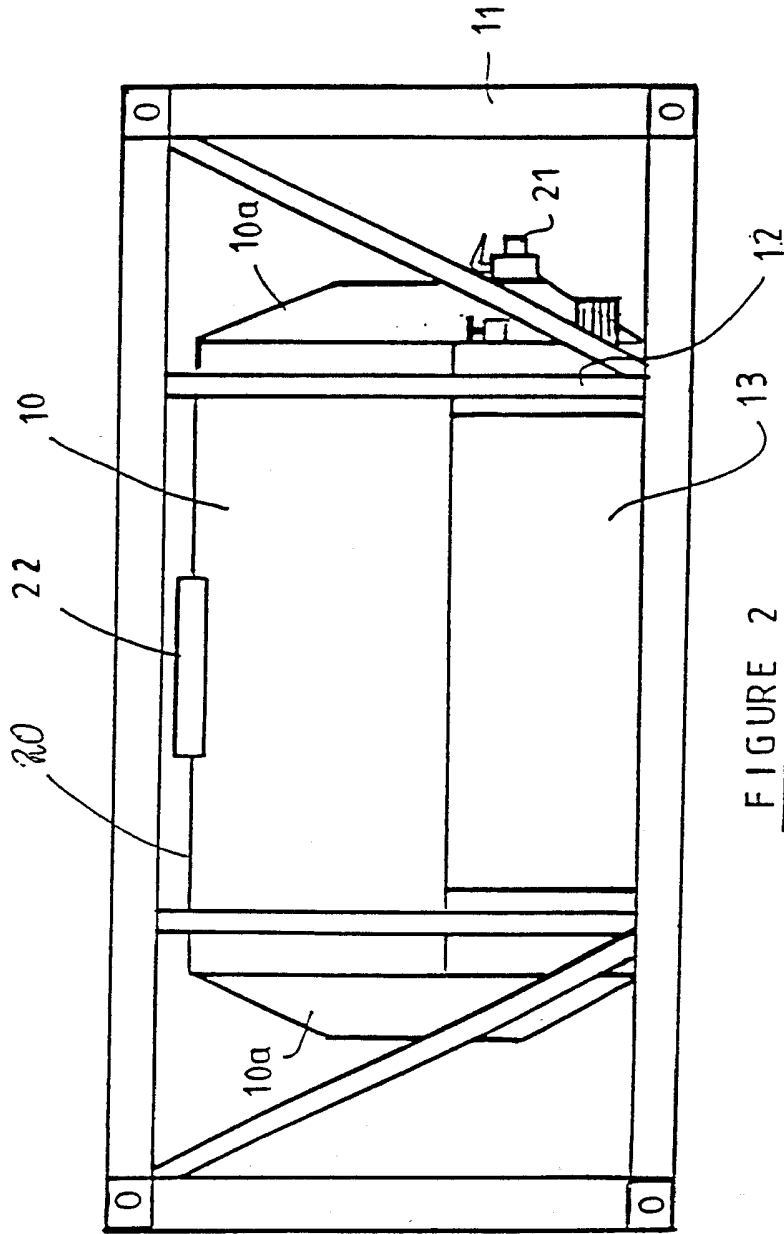

FIGURE 2

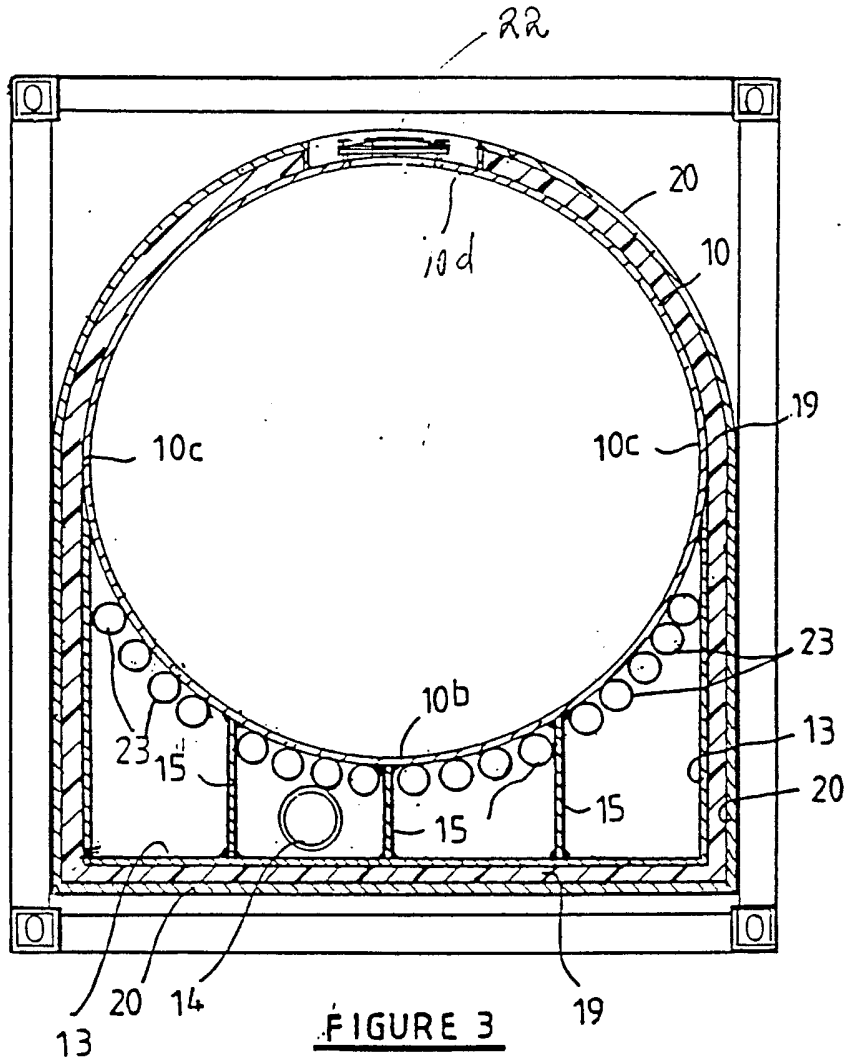

FIGURE 3

AP/P/97/01155

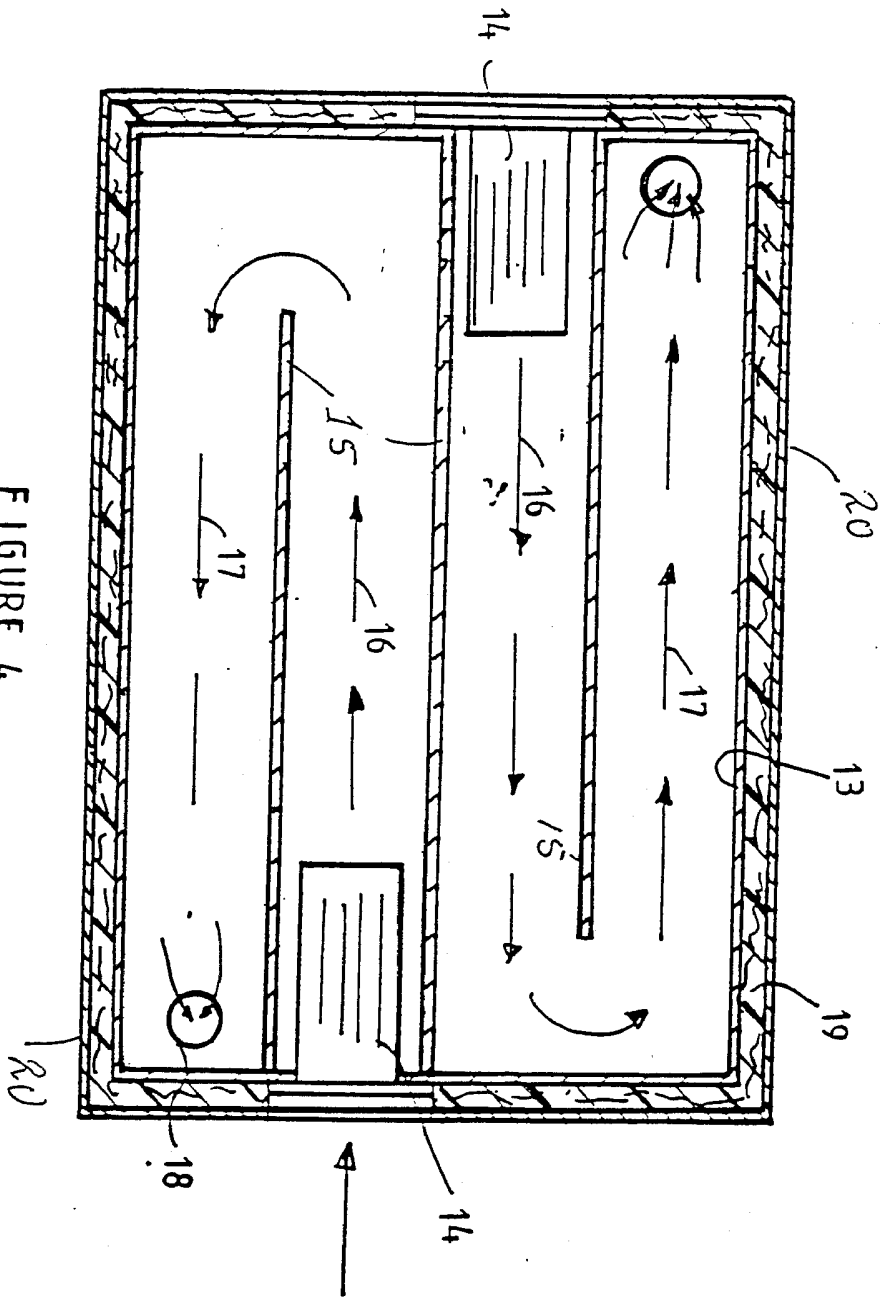

FIGURE 4

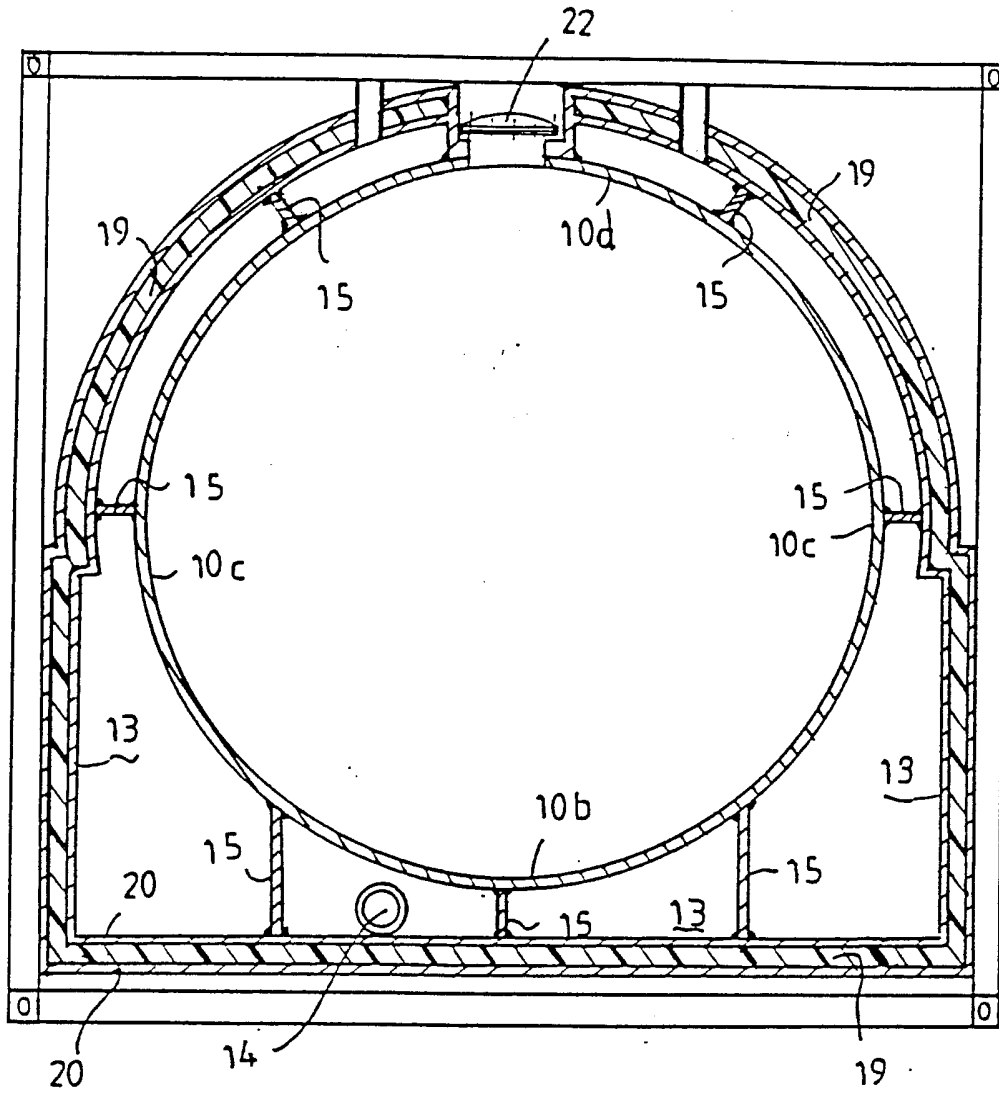

FIGURE 5

AP/P/97/01155

AP 00962

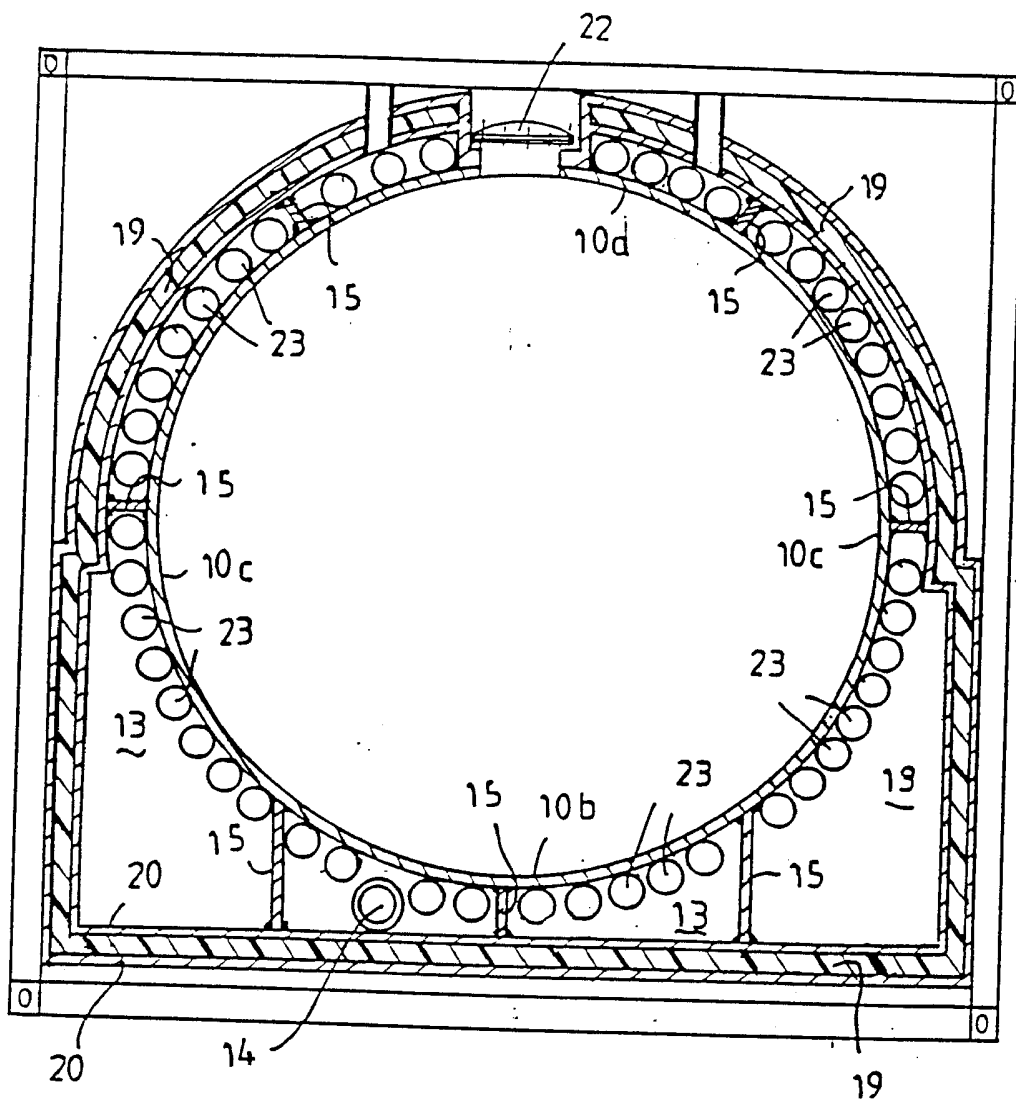

FIGURE 6

AP/P/97/01155