



(51) International Patent Classification:

B64D 45/02 (2006.01) *F16B 33/00* (2006.01)
F16B 37/14 (2006.01)

(21) International Application Number:

PCT/GB2014/050169

(22) International Filing Date:

22 January 2014 (22.01.2014)

(25) Filing Language:

English

(26) Publication Language:

English

(30) Priority Data:

1301703.3 31 January 2013 (31.01.2013) GB

(71) Applicant: AIRBUS OPERATIONS LIMITED

[GB/GB]; Pegasus House, Aerospace Avenue, Filton, Bristol Bristol BS99 7AR (GB).

(72) Inventors: DOBBIN, Richard; Pegasus House, Aerospace Park, Filton, Bristol Bristol BS99 7AR (GB). CREW, Darren; Pegasus House, Aerospace Park, Filton, Bristol Bristol BS99 7AR (GB).

(74) Agent: BEATSON, Matthew; Pegasus House, Aerospace Avenue, Filton, Bristol Bristol BS99 7AR (GB).

(81) Designated States (unless otherwise indicated, for every kind of national protection available):

AE, AG, AL, AM, AO, AT, AU, AZ, BA, BB, BG, BH, BN, BR, BW, BY, BZ, CA, CH, CL, CN, CO, CR, CU, CZ, DE, DK, DM, DO, DZ, EC, EE, EG, ES, FI, GB, GD, GE, GH, GM, GT, HN, HR, HU, ID, IL, IN, IR, IS, JP, KE, KG, KN, KP, KR, KZ, LA, LC, LK, LR, LS, LT, LU, LY, MA, MD, ME, MG, MK, MN, MW, MX, MY, MZ, NA, NG, NI, NO, NZ, OM, PA, PE, PG, PH, PL, PT, QA, RO, RS, RU, RW, SA, SC, SD, SE, SG, SK, SL, SM, ST, SV, SY, TH, TJ, TM, TN, TR, TT, TZ, UA, UG, US, UZ, VC, VN, ZA, ZM, ZW.

(84) Designated States (unless otherwise indicated, for every kind of regional protection available):

ARIPO (BW, GH, GM, KE, LR, LS, MW, MZ, NA, RW, SD, SL, SZ, TZ, UG, ZM, ZW), Eurasian (AM, AZ, BY, KG, KZ, RU, TJ, TM), European (AL, AT, BE, BG, CH, CY, CZ, DE, DK, EE, ES, FI, FR, GB, GR, HR, HU, IE, IS, IT, LT, LU, LV, MC, MK, MT, NL, NO, PL, PT, RO, RS, SE, SI, SK, SM, TR), OAPI (BF, BJ, CF, CG, CI, CM, GA, GN, GQ, GW, KM, ML, MR, NE, SN, TD, TG).

Published:

— with international search report (Art. 21(3))

(54) Title: CAP ASSEMBLY

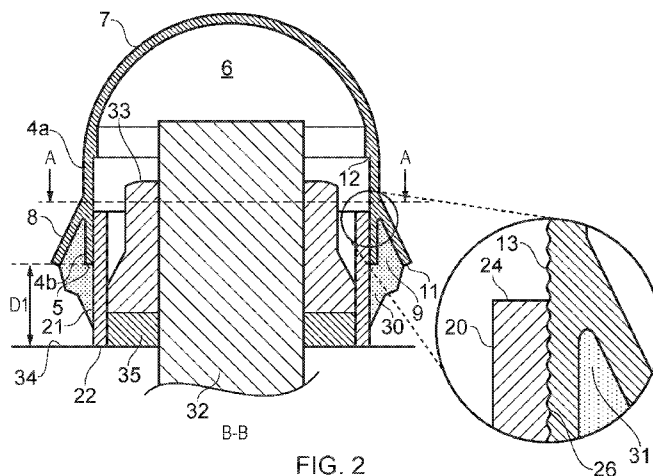

FIG. 2

(57) Abstract: A cap assembly for forming a sealed cavity around one end of a fastener. The cap assembly has a plunger (1) with a body (4a, 4b) terminating at a plunger rim (5) which surrounds a plunger opening (6a), and a skirt (8) extending outwardly from the body (4a, 4b) at a point which is set back from the plunger rim (5) so as to define a pocket (9) between the body (4a, 4b) and the skirt (8). The cap assembly also has a base (2) terminating at a base rim (22) which surrounds a base opening. The plunger (1) is fitted over the base (2) and is slidably movable relative to the base (2). The base (2) is partially received within the plunger (1) and partially protrudes from the plunger opening (6a) so that the plunger rim (5) is set back from the base rim (22). A bead of sealant material (30) is provided in the pocket (9), the sealant material (30) preferably being a flowable material such as polysulphide. The bead of sealant material (30) may be contained entirely within the pocket (9) or more preferably it protrudes from the pocket (9).

WO 2014/118509 A1

CAP ASSEMBLY

FIELD OF THE INVENTION

The present invention relates to a cap assembly for forming a sealed cavity around one
5 end of a fastener, a kit of parts for forming a cap assembly, a method of installing a
cap assembly, and a joint formed using a cap assembly.

BACKGROUND OF THE INVENTION

A known cap assembly for forming a sealed cavity around one end of a fastener is
described in WO-A-2012/107741. The assembly comprises an inner cap member with
10 an annular base terminating at an edge which surrounds an opening into a central
cavity, and an outer cap member which fits over the inner cap member. The outer cap
member has an annular base which forms an annular flange extending outwardly from
the inner cap member at a point which is set back from the edge of the annular base of
the inner cap member so as to define a pocket between the flange and the base. A
15 sealant material is provided between the inner plunger member and the outer plunger
member. During installation the outer plunger member is pushed down so the sealant
material flows into the pocket and adheres the cap to a structure.

Another known cap assembly for forming a sealed cavity around one end of a fastener
is described in WO-A-2012/118855. The assembly has an outer cap filled partially
20 with sealant, and an inner collet. The outer cap engages the inner collet via a plurality
of lock ribs, and the sealant extrudes between the cap and the collet via the gaps
between the lock ribs.

SUMMARY OF THE INVENTION

A first aspect of the invention provides a cap assembly for forming a sealed cavity
25 around one end of a fastener, the cap assembly comprising: a plunger with a body
terminating at a plunger rim which surrounds a plunger opening, and a skirt extending
outwardly from the body at a point which is set back from the plunger rim so as to
define a pocket between the body and the skirt; and a base terminating at a base rim

surrounds a base opening, wherein the plunger is fitted over the base and is slidably movable in an axial direction relative to the base, and wherein the plunger or the base comprises a cap with an end wall opposite the plunger opening or the base opening.

- 5 Preferably the body of the plunger has a collar (which is typically cylindrical) between the plunger rim and the point where the skirt extends outwardly from the body. A pocket is defined between this collar of the body and the skirt. The point which is set back from the plunger rim is set back in an axial outboard direction, that is a direction which is parallel with an axis of the cap assembly and directed from the opening into
- 10 the cavity.

Preferably the base is partially received within the plunger and partially protrudes from the plunger opening so that the plunger rim is set back (again, in an axial outboard direction) from the base rim. Typically the plunger rim lies in a plane which is set back from a plane of the base rim.

- 15 The plunger may comprise a cap with an end wall opposite the plunger opening. In this case the base may also comprise a cap but more preferably it is open at both ends - that is the base has a second opening opposite the base opening.

The base may comprise a cap with an end wall opposite the base opening. In this case the plunger is preferably open at both ends - that is the plunger has a second opening

20 opposite the plunger opening.

A bead of sealant material may be provided in the pocket, the sealant material preferably comprising a flowable material such as polysulphide. The bead of sealant material may be contained entirely within the pocket or more preferably it protrudes from the pocket.

- 25 The skirt may extend from the body at right angles and then axially to form the pocket, but more preferably it is flared so that it extends at an acute angle to the body which is less than 90° but greater than 0° . Typically the acute angle is between 20° and 40° .

lly the pocket has a pocket opening defined by the plunger rim and a rim of the flange, and a surface area of the pocket is greater than an area of the pocket opening.

The plunger is axially slidably movable relative to the base from a first position to a second position (where the axial length of the cap assembly is typically reduced). The
5 end wall may completely close an outboard end of the cap, or it may have one or more small holes which allow air to escape as the plunger is moved to its second position.

The plunger may have a stop which engages the base when the outer plunger is in the second position. The stop typically comprises a shoulder in an inner surface of the body of the plunger which extends around a circumference of the inner surface of the
10 body of the plunger. This circumference may be circular or any other shape.

The stop may engage an outboard rim of the base, or the base may comprise an outer surface with a shoulder which extends around a circumference of the outer surface of the base and which engages the stop when the plunger is in the second position. This circumference may be circular or any other shape.

15 The plunger rim may be set back from the base rim when the plunger is in the second position, or it may lie in the same plane as the base rim when the plunger is in the second position.

The plunger may engage the base via one or more annular recesses or protrusions. Thus for example the body of the plunger may have one or more recesses or
20 protrusions which run around a circumference of the body, wherein the recess(es) or protrusion(s) lie in a plane which is substantially parallel with a plane of the plunger rim and can interlock with one or more corresponding protrusions or recesses in the base. Typically the recess(es) or protrusion(s) in the body of the plunger can interlock with the corresponding protrusion(s) or recess(es) in the base when the plunger is in
25 the first position and/or in the second position.

The recess and protrusion ensure that the plane of the plunger rim remains aligned parallel with the plane of the base rim, and can be used to hold the plunger and base securely in place when the plunger is in the first or second position. Where they interlock in the second position, then they can interlock via a “snap-fit” connection
30 which provides a tactile indication to a user that the plunger is in the second position.

ably the base has three or more protrusions which extend inwardly into an interior of the base and are spaced apart around a circumference of the interior of the base (which circumference may be circular or any other shape).

Typically the body has an inner face and an outer face, and at least part of the inner
5 face and/or the outer face of the body is substantially cylindrical. The inner face and/or the outer face of the body may be substantially cylindrical in a collar of the body between the plunger rim and the point where the skirt extends outwardly from the body.

The plunger body may engage the base around a majority of its circumference.

10 Preferably the plunger body engages the base around a majority of its circumference when viewed in cross-section transverse to the axial direction. Small gaps may be present (or in the case of the joint, regions of sealant which has flowed from the pocket during installation) but preferably the plunger body engages the base around its entire circumference when viewed in cross-section.

15 Preferably the plunger body and the base have inner and outer surfaces respectively which are in engagement and have substantially the same shape (for instance circular) around their full circumference when viewed in cross-section transverse to the axial direction.

Preferably the end wall has a domed shape.

20 The plunger rim may lie in the same plane as a rim of the skirt, or it may be set back from the rim of the skirt.

A further aspect of the invention provides a kit of parts according to claim 13 for forming a cap assembly according to the first aspect of the invention.

A further aspect of the invention provides a joint according to claim 14.

25 A further aspect of the invention provides a method of providing a sealed cavity around one end of a fastener according to claim 19.

alant material is adhered to the cap assembly via a first interface and to the structure via a second interface. Typically a surface area of the first interface is greater than a surface area of the second interface. The first interface may consist of a plunger interface between the sealant and the plunger, with no interface between the sealant and the base. Alternatively the first interface may comprise a plunger interface between the sealant and the plunger and a base interface between the sealant and the base. Typically an adhesive strength of the first interface is greater than 100N and most preferably it is greater than 300N.

Preferably the base is partially received within the plunger cavity and partially protrudes from the end of the plunger cavity so that the plunger rim is set back axially from the base rim. This enables the sealant material to adhere to the protruding part of the base. Typically the plunger rim lies in a plane which is set back in an axial outboard direction from a plane of the base rim.

Similarly the skirt may have a skirt rim which is set back from the base rim. The skirt rim typically lies in a plane which is set back in an axial outboard direction from a plane of the base rim.

In one embodiment, the base is the cap, the plunger comprises an inboard plunger opening, the base comprises an inboard end including the base rim which protrudes from the inboard plunger opening, and the plunger further comprises an outboard plunger opening opposite the inboard plunger opening.

In another embodiment, the plunger is the cap, the plunger comprises an inboard plunger opening, the base comprises an inboard end including the base rim which protrudes from the inboard plunger opening, and the base further comprises an outboard base opening opposite the inboard base opening.

Typically the base has three or more protrusions which extend inwardly into an interior of the base and are spaced apart around a circumference of the interior of the base.

Typically the fastener is received within the base and engages the base, optionally via the three or more protrusions of the base which extend inwardly into the interior of the base and are spaced apart around its circumference.

ably the base rim engages the structure or the fastener. In a preferred embodiment the base rim engages the structure.

The end of the fastener may protrude from the structure, in which case the base rim surrounds the protruding end of the fastener. Alternatively the end of the fastener may
5 lie flush with the structure or be countersunk within the structure, in which case the base rim surrounds the hole in the structure in which the fastener is countersunk.

Preferably the plunger does not engage the structure. Preferably the plunger does not engage the fastener. Most preferably the plunger does not engage either the structure or the fastener.

10 The cap assembly may be provided for the purpose of spark containment, for instance on an aircraft or a fuel tanker. In this case at least part of the structure through which the fastener passes typically comprises a composite material, and the fastener is electrically conductive. The structure may comprise a pure composite material, or a
15 hybrid composite/metal material. Typically the composite material is a laminar fibre-reinforced composite material, where the fibres are a conductive material such as carbon, and the matrix between the fibres has low conductivity. Alternatively the cap assembly may be used to seal the end of a fastener to prevent the ingress of a liquid (such as fuel). In this case the structure may not contain any composite material.

The structure typically comprises a pair of structural parts (for instance panels) which
20 are joined together by the fastener.

The fastener may comprise a shaft with a head at one end; and a collar fitted to a second end of the shaft (the collar may for instance be a nut which is screwed onto the shaft, or a collar which is swaged onto the shaft). The plunger may be used to form a sealed cavity at either the first or second end of such a fastener. The end of the
25 fastener may be housed within the cap assembly, or it may be countersunk within the structure (in which case the end of the fastener will lie outside the cap assembly).

BRIEF DESCRIPTION OF THE DRAWINGS

Embodiments of the invention will now be described with reference to the accompanying drawings, in which:

1 shows a kit of parts for forming a cap assembly;

Figure 2 is a cross-sectional view of the cap assembly in a first installation state taken along a line B-B in Figure 3;

5 Figure 3 is a cross-sectional view of the cap assembly taken along a line A-A in Figure 2;

Figure 4 is a cross-sectional view of the cap assembly in a second installation state;

Figure 5 is an enlarged cross-sectional view;

10 Figure 6 is a cross-sectional view of a cap assembly according to a second embodiment of the invention in a first installation state taken along a line D-D in Figure 7;

Figure 7 is a cross-sectional view of the cap assembly taken along a line C-C in Figure 6;

Figure 8 is a cross-sectional view of the cap assembly in a second installation state; and

15 Figure 9 is an enlarged cross-sectional view.

DETAILED DESCRIPTION OF EMBODIMENT(S)

20 A kit of parts for forming a cap assembly is shown in Figure 1. The kit comprises a plunger 1 and a base 2, each formed from a moulded polymer such as polyetherimide ULTEM 2400, or an epoxy. The plunger 1 and the base 2 each have an inboard end and an outboard end (at the bottom and top respectively in the orientation of Figure 1).

25 The plunger 1 has a generally cylindrical body with an outboard part 4a and a collar 4b at its inboard end. Both parts 4a, 4b have substantially cylindrical inner and outer faces. The collar 4b terminates at an annular plunger rim 5 at its inboard end which surrounds a circular plunger opening 6a into a plunger cavity 6. A domed end wall 7 closes the plunger cavity 6 at its outboard end opposite the plunger opening 6a and plunger rim 5. A frustoconical skirt or flange 8 extends outwardly from the outer face of the body at the junction between the parts 4a, 4b, at a point which is set back

from the plunger rim 5 in the outboard direction. An annular pocket or trough 9 is defined between the outer face of the collar 4b and the inner face of the skirt 8.

The pocket 9 has an annular opening 10 between the plunger rim 5 and a rim 11 of the skirt. A surface area of the pocket 9 (given by the sum of the areas of the cylindrical outer face of the collar 4b and the frustoconical inner face of the skirt 8) is greater than the area of the pocket opening 10. The inner face of the cap body is formed with an annular shoulder 12 running round its circumference. The inner face of the cap body is also formed with series of annular ridges 13 running round its circumference as shown in Figure 2. The shoulder 12 and ridges 13 all lie in planes which are substantially parallel with the plane of the plunger rim 5 and the skirt rim 11. The plunger rim 5 lies in approximately the same plane as the skirt rim 11.

The base 2 has cylindrical inner and outer faces 20, 21, the inner face 20 being shown in Figure 3. The base terminates at a circular inboard base rim 22 which surrounds an inboard base opening, and a circular outboard base rim 24 which surrounds an outboard base opening. Thus the base is open at both its inboard (lower) and outboard (upper) ends. Six semi-cylindrical ridges or protrusions 25 extend inwardly from the inner face 20 of the base into its interior and are spaced apart equally around its circumference. The ridges 25 run along the full axial length of the base. The outer face 21 of the base has a series of annular grooves 26 shown in Figure 2 which lie substantially parallel to the planes of the base rims 22, 24 and match the pitch and shape of the ridges 13 in the plunger.

Prior to installation on a fastener as shown in Figure 2, the plunger 1 is fitted over the base 2 to form a cap assembly shown in Figure 2. The plunger and base are urged together until a number of the annular ridges 13 are received in corresponding annular grooves 26 as shown in Figure 2. The ridges 13 and grooves 26 hold the plunger and base securely in place prior to installation and ensure that the plane of the plunger rim 5 remains aligned parallel with the plane of the base rim 22. In the configuration of Figure 2 the base is partially received within the plunger cavity 6 and partially protrudes from the opening 6a at the inboard end of the plunger cavity so that the plunger rim 5 and skirt rim 11 are set back axially from the base rim 22 in the outboard direction by a distance D1.

he plunger has been fitted over the base to form a cap assembly shown in Figure 2, a band of polysulphide sealant material 30 is installed in the pocket 9. The sealant is extruded from a nozzle to apply a metered quantity into the pocket. As the sealant is extruded, the nozzle and/or the cap assembly is moved so the sealant forms a
5 bead around the full circumference of the pocket 9. The bead over-fills the pocket so that part of the sealant material 30 fills the pocket and part protrudes from the opening 10 of the pocket as shown in Figure 2. The sealant may be applied in a single pass around the pocket or as a series of layers laid down in a series of passes. Optionally the nozzle may be angled at an acute angle to the plunger axis to ensure that sealant is
10 fed all the way into the corner 31 of the pocket. The sealant can be applied immediately prior to installation or could be supplied pre-installed in a frozen state.

The cap assembly is used to form a sealed cavity around a protruding end of a fastener assembly as shown in Figure 2. The fastener assembly comprises a metal bolt 32 passing through a composite panel 34. A washer 35 is fitted onto the protruding part
15 of the bolt 32. An internally threaded metal nut 33 is screwed onto the bolt 32 and compresses the washer 35 against the panel 34. Optionally the washer 35 and nut 33 may have spherical surfaces as described in WO2012/107741 to enable the fastener to be fixed to the panel even though the bolt is not perpendicular to the panel.

In a first installation step shown in Figure 2 the cap assembly is pushed onto the
20 fastener until the inboard rim 22 of the base engages the panel 34. The base 2 is sized so that the protrusions 25 engage the cylindrical outer surfaces of the nut 33 and washer 35 as a frictional or interference fit. The protrusions 25 provide a standoff between the fastener and the inner face 20 of the base. They also grip the fastener so that the cap assembly is prevented from falling off under the action of gravity if the
25 panel 34 is downward facing (that is, if the panel 34 is in the opposite orientation to Figure 2).

Next the plunger 1 is pushed inboard towards the panel 34 and slides axially relative to the base from the first position shown in Figure 2 until the shoulder 12 engages the outboard rim 24 of the base in a second position shown in Figure 4. The rims 5, 11
30 are set back from the base rim by a distance D1 when the plunger is in the first

n of Figure 2 and by a smaller distance D2 when the plunger is in the second position of Figure 4.

5 The skirt 8 of the sliding plunger 1 pushes the sealant 30 against the panel which then flows to form a seal against the panel as shown in Figure 4. The inboard protruding part of the base 2 prevents the flowing sealant from flowing directly into the cavity 6 during this process. In comparison with the outer plunger in WO-A-2012/107741, only a relatively small amount of force is required to push the plunger 1 down from the first position of Figure 2 to the second position of Figure 4. The sealant then cures and adheres the cap assembly to the panel 34.

10 As can be seen in Figure 3, the inner surface of the body of the plunger 1 and the outer surface 21 of the base are both circular when viewed in cross-section transverse to the axis of the cap assembly in the axial direction of motion of the plunger as it is pushed down. These two circular surfaces engage each other as a frictional fit (by way of the ridges 13 and protrusions 26) around substantially their full circumference without
15 any large gaps.

When the cap assembly is in a pre-installation state, before the base is pushed onto the fastener, then both the inner surface of the body of the plunger 1 and the outer surface 21 of the base will be substantially the same shape in cross-section (circular in this case). When the base is pushed onto the fastener, then the outer surface 21 of the base
20 will distort slightly from a circular cross-section to form a three-lobed shape (each lobe corresponding with a respective one of the protrusions 25). The body of the plunger 1 is sufficiently flexible that it will also distort slightly so that its inner surface forms a similar three-lobed shape and continues to engage the outer surface 21 of the base around substantially its full circumference.

25 As the plunger 1 moves from the first position of Figure 2 to the second position of Figure 4, it continues to engage the outer surface 21 of the base (by way of the ridges 13 and protrusions 26) around substantially its full circumference without any large gaps. The absence of such large gaps prevents, or at least impedes, the flow of sealant into the sliding interface between the plunger and the base. If a small amount of
30 sealant does flow into this sliding interface, then this may be beneficial since it creates an additional bond between the plunger and the base. The undulating shape of the

ce (created by the interlocking ridges 13 and grooves 26) will tend to prevent sealant from flowing all the way into the cavity 6.

The sealed cavity 6 provided by the cap assembly contains any sparking, plasma or out-gassing caused by a lightning strike. The cap assembly may be immersed in fuel, in which case the sealant also prevents the ingress of fuel into the cavity.

Air from the plunger cavity 6 can escape as the plunger is pushed towards the panel by passing through the sliding interface between the base and the plunger and then through the interface between the sealant and the base. Alternatively a small hole may be provided in the apex 7a (Figure 4) of the domed end wall 7 to allow this air to escape more easily. This hole can be filled with polysulphide sealant or epoxy resin after installation to fully seal the cavity 6 around the fastener.

The panel may be flat as shown in Figure 1 or it may have raised features (not shown) on both sides, which may be for example fillets, ribs or spar flanges. The rim of the skirt 8 is set back axially from the panel 34 and the base rim 22 by a distance D2 when the plunger is in the second position of Figure 4 and 5. This enables the plunger to be positioned close to such raised features.

The sealant material 30 is adhered to the cap assembly 1,2 via a first interface and to the panel 34 via a second interface as shown in Figure 5. The first interface comprises a plunger interface between the sealant 30 and the plunger 1 and a base interface between the sealant 30 and the base 2. A surface area of the first interface (given by the sum of the areas of the cylindrical outer face of the collar 4b, the frustoconical inner face 8a of the skirt 8, the annular rim 5, and the cylindrical outer face 21 of the base 2 between the plunger rim 5 and the base rim 22) is greater than a surface area of the second interface. This large surface area reduces the risk of adhesive failure at this first interface 4b, 8a, 5, 21.

If the sealed cap assembly is pulled away from the panel 34, then failure will typically occur by adhesive failure at the first interface or by cohesive failure within the bead of sealant 30. Preferably the strength of the adhesive bond is of the order of 400-500N at both the first and second interfaces.

ally the shoulder 12 in the plunger can be omitted so the plunger can be pushed all the way down to engage the panel 34. However this arrangement is less preferred because it reduces the area of the first interface and prevents the plunger from being positioned close to any raised features in the panel 34. It also prevents a seal being
5 formed between the sealant and the base.

A cap assembly according to a second embodiment of the invention is shown in Figures 6-9. In contrast to the embodiment of Figure 1, the base is formed as a cap rather than the plunger. Although the cap assembly is not shown as a kit of two parts, it can be provided as an unassembled kit as shown in Figure 1.

10 The cap assembly comprises a plunger 101 and a base 102, each formed from a moulded polymer such as polyetherimide ULTEM 2400, or an epoxy. Many parts of the plunger 101 and base 102 are similar to the first embodiment, so such similar parts will not be described again.

The plunger 101 has a body with an outboard part 104a and a collar 104b. Both parts
15 104a,104b have substantially cylindrical inner and outer faces. The plunger 101 is open at both its inboard (lower) and outboard (upper) ends. The rim 111 of the skirt 108 curves upwards at its end to form an outwardly extending flange.

The inner face of the plunger body is formed with an annular shoulder 112 running round its circumference towards its outboard end, and a single annular recess or
20 groove 113 also running round its circumference, towards the inboard end of the collar 104b. The shoulder 112 and recess 113 lie in planes which are substantially parallel to the planes of the rims 105, 111, 124. The collar 104b is shorter than the axial extent of the skirt 108 so that the plunger rim 105 is set back axially in the outboard direction from the skirt rim 111.

25 The base 102 is a cap having a tubular body with cylindrical inner and outer faces 120, 121. A domed end wall 117 closes the base cavity 106 at its outboard end opposite a base opening at the inboard end of the base. Six cut-outs are formed in the inner face of the base, leaving six semi-cylindrical ridges or protrusions 125 extending
30 inwardly from the inner face 120 of the base into the base cavity 106 and spaced apart equally around its circumference. The outer face of the base is formed with an

rd facing annular shoulder 127 running round its circumference, and a single annular ridge or protrusion 128 also running round its circumference, towards its inboard end. The shoulder 127 and ridge 128 lie in planes which are substantially parallel to the plane of the base rim 122.

- 5 In the configuration of Figure 6 the base is partially received within the plunger and partially protrudes from the inboard end of the plunger by a distance D3.

After the plunger has been fitted over the base to form a cap assembly shown in Figure 6, a band of polysulphide sealant material 130 is installed in the pocket using a similar process to the one described above.

- 10 The plunger 101 is pushed inboard towards the panel and slides axially relative to the base from the first position shown in Figure 6 until the shoulder 112 of the plunger engages the shoulder 127 of the base in a second position shown in Figure 8, and the ridge 128 is received in the recess 113 as a snap fit as shown in Figure 9. The ridge 128 and recess 113 ensure that the planes of the rims 122, 111, 105 remain parallel,
15 and hold the plunger and base securely in place while the sealant cures. They also interlock via a “snap-fit” connection which provides a tactile indication to a user that the plunger is in the second position.

- The plunger rim 105 is set back from the base rim in the outboard direction by a distance D3 when the plunger is in the first position of Figure 6 and by a smaller
20 distance D5 when the plunger is in the second position of Figures 8 and 9.

The skirt 108 of the sliding plunger 101 pushes the sealant 130 which flows to form a seal against the panel as shown in Figures 8 and 9. The protruding part of the base 102 prevents the flowing sealant from flowing into the base cavity 106 during this process. The sealant then cures and adheres the cap assembly to the panel.

- 25 As the plunger 101 moves from the first position of Figure 6 to the second position of Figure 8, it engages the outer surface 121 of the base around substantially its full circumference without any large gaps as shown in Figure 7. The absence of such large gaps prevents, or at least impedes, the flow of sealant into this sliding interface between the plunger and the base.

n 111 of the skirt 108 is set back axially from the panel and from the base rim 122 by a distance D5 when the plunger is in the second position of Figure 9. This enables the plunger to be positioned close to any raised features.

5 Optionally the shoulders 112, 127 can be omitted so the plunger 101 can be pushed all the way down to engage the panel.

In all embodiments of the invention where various features are described as being annular, these parts are also circular. Note however that in the case of a non-circular (for instance square or hexagonal) cap assembly then these annular features will have a non-circular shape. Therefore the term “annular” is used herein to refer to a feature 10 (for instance a shoulder, protrusion or recess) which runs round a circumference of the cap assembly regardless of the shape of that circumference.

Although the invention has been described above with reference to one or more preferred embodiments, it will be appreciated that various changes or modifications may be made without departing from the scope of the invention as defined in the 15 appended claims.

Claims

1. A cap assembly for forming a sealed cavity around one end of a fastener, the cap assembly comprising:
 - 5 a plunger with a body terminating at a plunger rim which surrounds a plunger opening, and a skirt extending outwardly from the body at a point which is set back from the plunger rim so as to define a pocket between the body and the skirt; and
 - a base terminating at a base rim which surrounds a base opening,

wherein the plunger is fitted over the base and is slidably movable in an axial
10 direction relative to the base, and

wherein the plunger or the base comprises a cap with an end wall opposite the plunger opening or the base opening.
2. The cap assembly of claim 1 wherein the base is partially received within the plunger and partially protrudes from the plunger opening so that the plunger rim is
15 set back axially from the base rim.
3. The cap assembly of any preceding claim further comprising a bead of sealant material in the pocket.
4. The cap assembly of claim 3 wherein part of the bead of sealant material protrudes from the pocket.
- 20 5. The cap assembly of any preceding claim wherein the plunger comprises a cap with an end wall opposite the plunger opening.
6. The cap assembly of any preceding claim wherein the base comprises a cap with an end wall opposite the base opening.
7. The cap assembly of any preceding claim wherein the end wall completely closes
25 an end of the cap.

- 5 a cap assembly of any preceding claim wherein the plunger is slidably movable in an axial direction relative to the base from a first position to a second position, an axial spacing between the rims reduces as the plunger slides from the first position to the second position, the plunger rim is set back axially from the base rim when the plunger is in the second position, the cap comprises a cap body surrounding a cap cavity and an end wall closing the cap cavity, and the cap body is formed with a stop which engages the base or the plunger when the plunger is in the second position and prevents the plunger from sliding further beyond the second position to further reduce the axial spacing between the rims.
- 10 9. The cap assembly of claim 8 wherein the stop comprises a shoulder formed in an inner or outer surface of the cap body.
10. The cap assembly of claim 9 wherein the shoulder is an annular shoulder which extends around a circumference of the inner or outer surface of the cap body.
- 15 11. The cap assembly of any preceding claim wherein the plunger has an annular recess or protrusion which is substantially parallel with a plane of the plunger rim, and the base has an annular protrusion or recess which is substantially parallel with a plane of the base rim.
- 20 12. The cap assembly of claim 11 wherein the plunger has three or more annular recesses or protrusions which are substantially parallel with a plane of the plunger rim, and the base has three or more annular protrusions or recesses which are substantially parallel with a plane of the base rim.
- 25 13. The cap assembly of any preceding claim wherein the body of the plunger comprises a collar between the plunger rim and the point where the skirt extends outwardly from the body, and the pocket is defined between the collar and the skirt.
14. A kit of parts for forming a cap assembly according to any preceding claim, the kit comprising:
- a plunger with a body terminating at a plunger rim which surrounds a plunger opening, and a skirt extending outwardly from the body at a point which is set

back from the plunger rim so as to define a pocket between the body and the skirt; and

a base terminating at a base rim which surrounds a base opening,

5 wherein the plunger or the base comprises a cap with an end wall opposite the plunger opening or the base opening, and

wherein the plunger can be fitted over the base so that it is slidably movable in an axial direction relative to the base.

15. A joint comprising: a structure; a fastener passing through the structure; and a cap assembly providing a sealed cavity around one end of the fastener, the cap assembly comprising:

10

a plunger with a body terminating at a plunger rim which surrounds a plunger opening, and a skirt extending outwardly from the body at a point which is set back from the plunger rim so as to define a pocket between the body and the skirt; and

15 a base terminating at a base rim which surrounds a base opening,

wherein the plunger is fitted over the base,

wherein a sealant material in the pocket adheres the plunger to the structure, and

20 wherein the plunger or the base comprises a cap with an end wall opposite the plunger opening or the base opening, the cap providing the sealed cavity around the one end of the fastener.

16. The joint of claim 15 wherein the sealant material is adhered to the cap assembly via a first interface and to the structure via a second interface, and wherein a surface area of the first interface is greater than a surface area of the second interface.

25 17. The joint of claim 15 or 16 wherein the sealant material is adhered to the cap assembly via a first interface and to the structure via a second interface, and

erein the first interface comprises a plunger interface between the sealant and the plunger and a base interface between the sealant and the base.

18. The joint of any of claims 15 to 17 wherein the sealant material is adhered to the cap assembly via a first interface and to the structure via a second interface, and
5 wherein an adhesive strength of the first interface is greater than 100N.
19. The joint of any of claims 15 to 18 wherein the base is partially received within the plunger and partially protrudes from the plunger opening so that the plunger rim is set back from the base rim.
20. The joint of any of claims 15 to 19 wherein the body of the plunger comprises a
10 collar between the plunger rim and the point where the skirt extends outwardly from the body, and the pocket is defined between the collar and the skirt.
21. A method of providing a sealed cavity around one end of a fastener passing through a structure, the method comprising:
- 15 providing a cap assembly according to any of claims 1 to 13, wherein the base is partially received within the plunger and partially protrudes from the plunger opening so that the plunger rim is set back axially from the base rim, and wherein the cap assembly further comprising a bead of sealant material in the pocket;
- engaging the structure or the fastener with the base rim;
- 20 pushing the plunger towards the structure so that the plunger slides axially relative to the base from a first position to a second position, the sliding plunger pushing the sealant which flows to form a seal against the structure; and
- curing the sealant so that the sealant adheres the plunger to the structure.

1/7

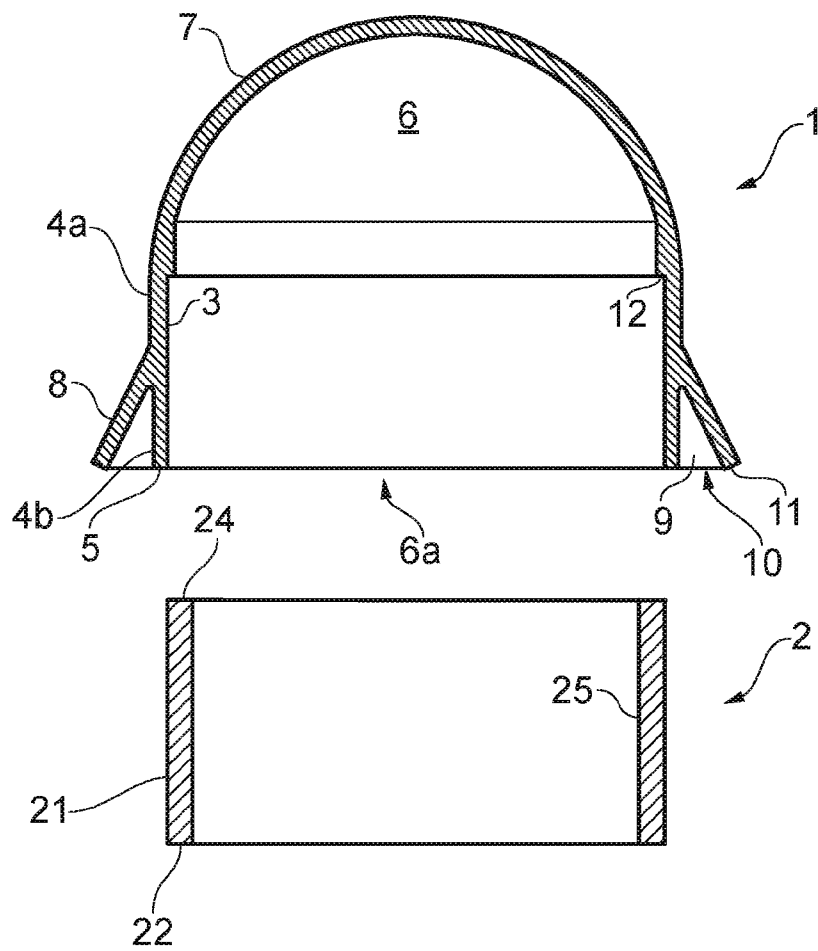

FIG. 1

2/7

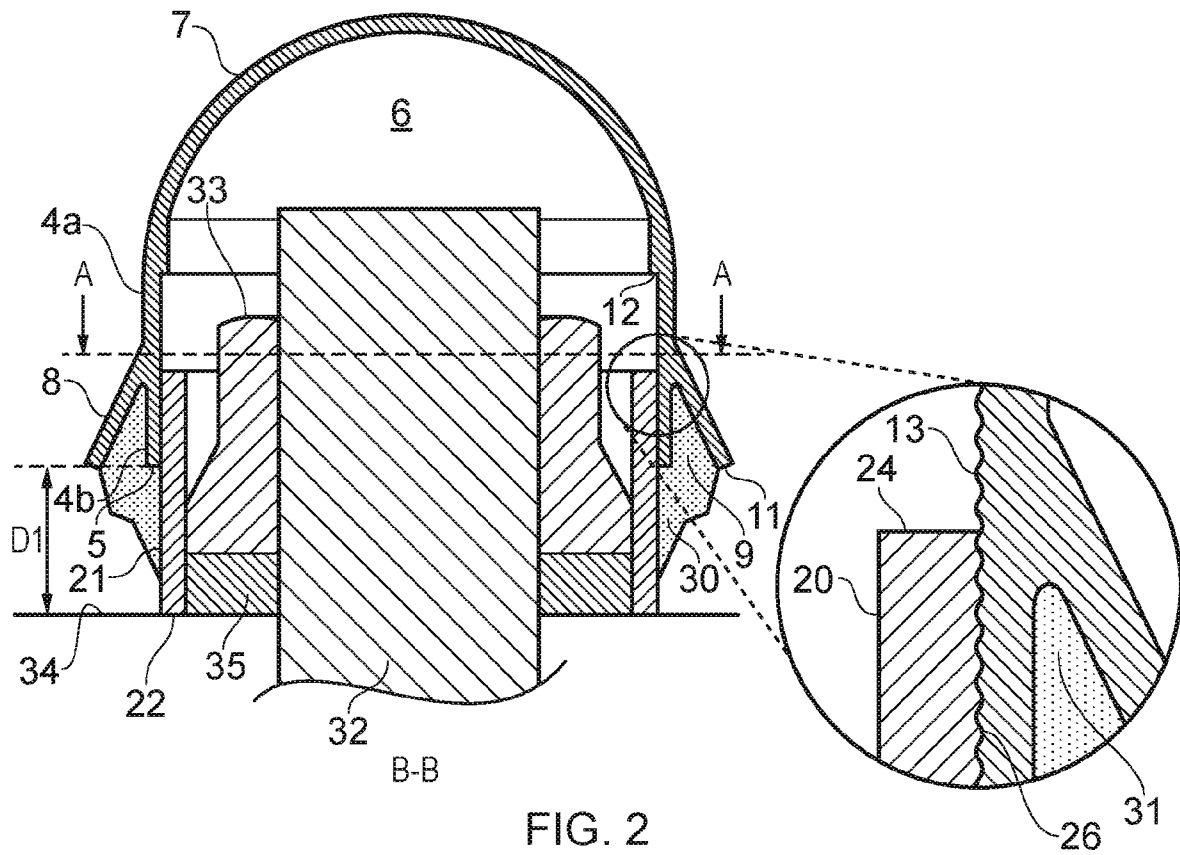

FIG. 2

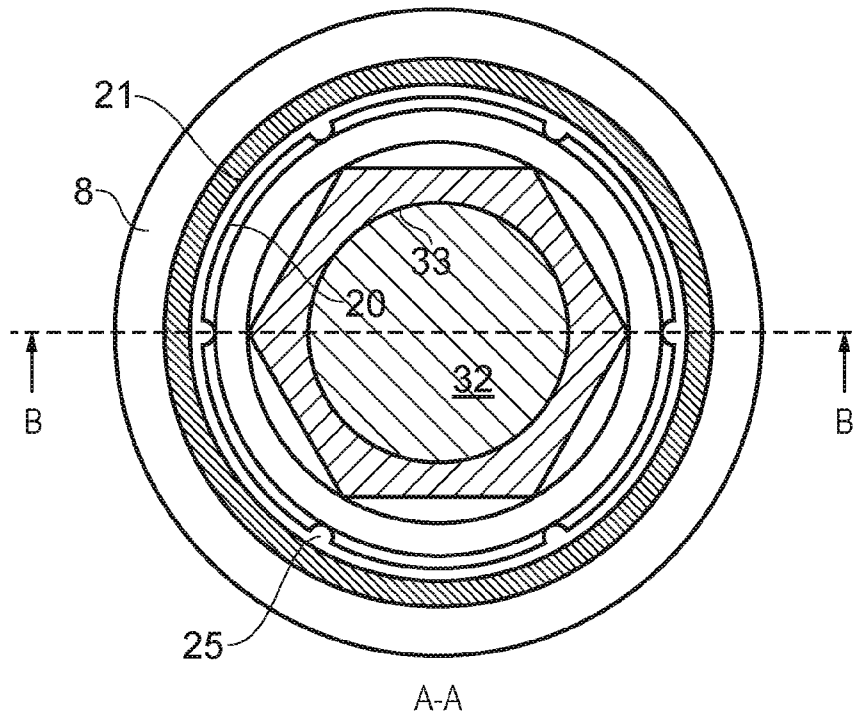

FIG. 3

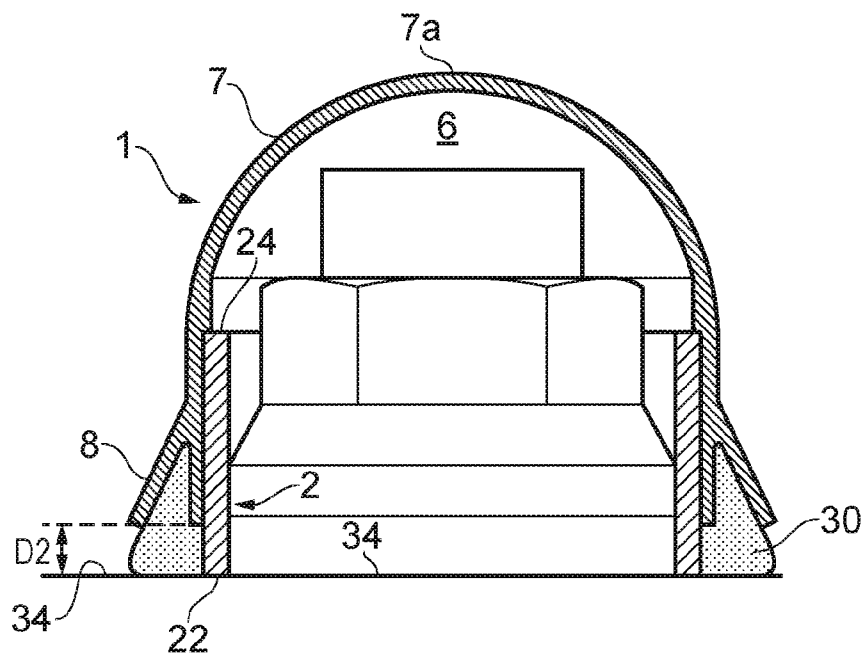

FIG. 4

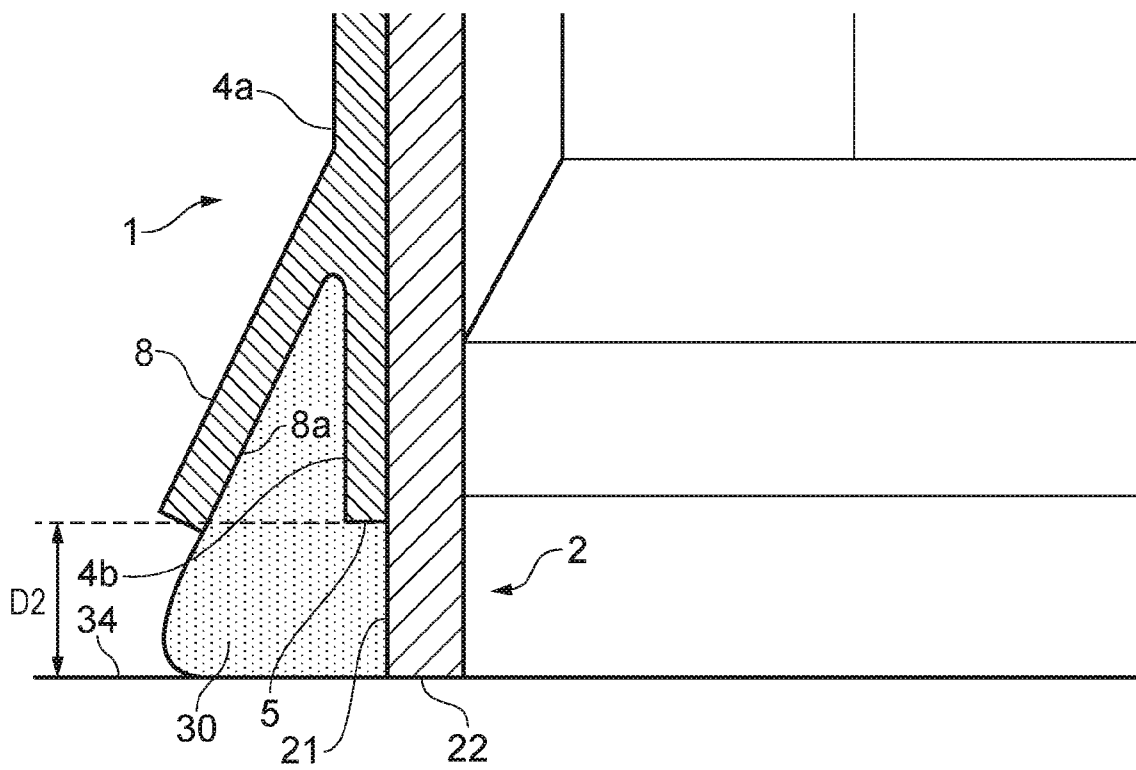

FIG. 5

6/7

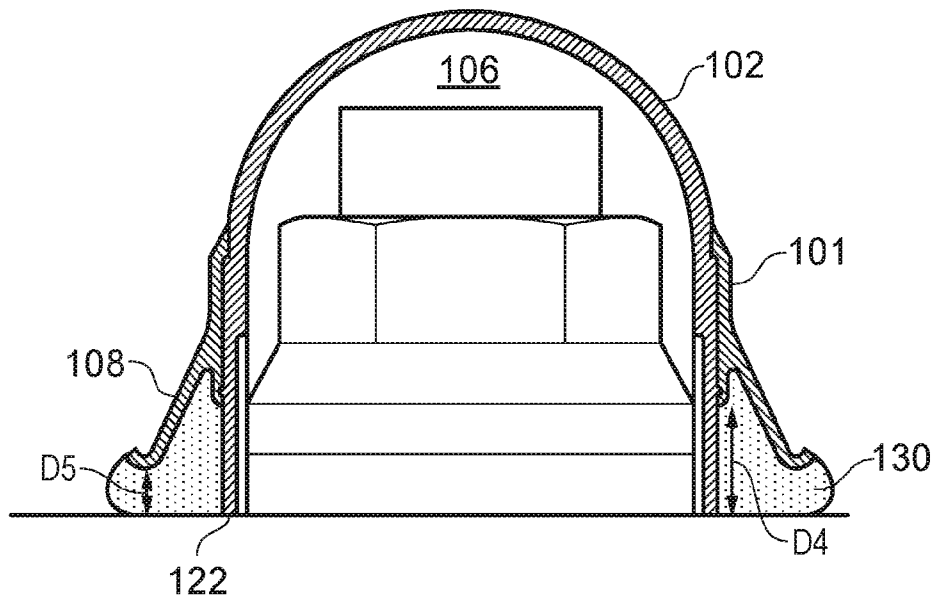

FIG. 8

7/7

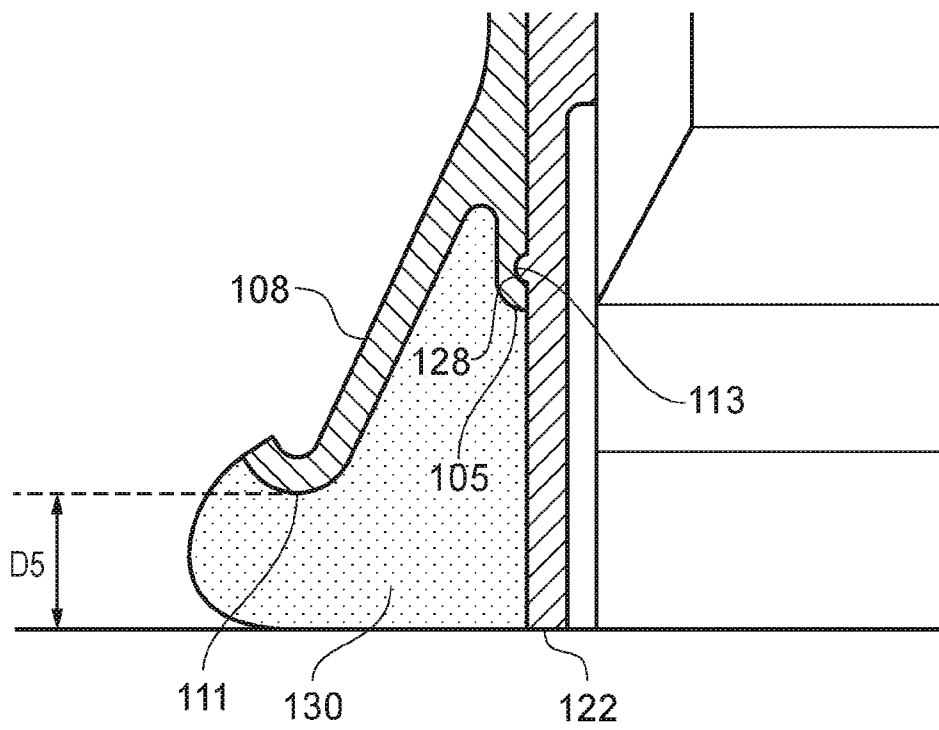

FIG. 9

INTERNATIONAL SEARCH REPORT

International application No

PCT/GB2014/050169

A. CLASSIFICATION OF SUBJECT MATTER
 INV. B64D45/02 F16B37/14
 ADD. F16B33/00

According to International Patent Classification (IPC) or to both national classification and IPC

B. FIELDS SEARCHED

Minimum documentation searched (classification system followed by classification symbols)
 B64D F16B

Documentation searched other than minimum documentation to the extent that such documents are included in the fields searched

Electronic data base consulted during the international search (name of data base and, where practicable, search terms used)

EPO-Internal, WPI Data

C. DOCUMENTS CONSIDERED TO BE RELEVANT

Category*	Citation of document, with indication, where appropriate, of the relevant passages	Relevant to claim No.
X Y A	DE 101 48 414 C1 (RADOLID THIEL GMBH [DE]) 6 March 2003 (2003-03-06) figures 1,2 paragraphs [0001], [0005] - [0009], [0015] - [0021]	1,2,6, 13,14 3-5, 7-12, 15-20 21
X	----- US 4 659 273 A (DUDLEY DANIEL P [US]) 21 April 1987 (1987-04-21) figures 1-6 page 2, lines 1-68	1,2,14
X	----- EP 0 040 667 A1 (TRAILER MARINE TRANSPORT CORP [US]) 2 December 1981 (1981-12-02) figures 1,2 page 2, line 12 - page 4, line 15 ----- -/--	1,14

Further documents are listed in the continuation of Box C.

See patent family annex.

* Special categories of cited documents :

"A" document defining the general state of the art which is not considered to be of particular relevance

"E" earlier application or patent but published on or after the international filing date

"L" document which may throw doubts on priority claim(s) or which is cited to establish the publication date of another citation or other special reason (as specified)

"O" document referring to an oral disclosure, use, exhibition or other means

"P" document published prior to the international filing date but later than the priority date claimed

"T" later document published after the international filing date or priority date and not in conflict with the application but cited to understand the principle or theory underlying the invention

"X" document of particular relevance; the claimed invention cannot be considered novel or cannot be considered to involve an inventive step when the document is taken alone

"Y" document of particular relevance; the claimed invention cannot be considered to involve an inventive step when the document is combined with one or more other such documents, such combination being obvious to a person skilled in the art

"&" document member of the same patent family

Date of the actual completion of the international search

23 April 2014

Date of mailing of the international search report

02/05/2014

Name and mailing address of the ISA/

European Patent Office, P.B. 5818 Patentlaan 2
 NL - 2280 HV Rijswijk
 Tel. (+31-70) 340-2040,
 Fax: (+31-70) 340-3016

Authorized officer

Schandel, Yannick

INTERNATIONAL SEARCH REPORT

International application No
PCT/GB2014/050169

C(Continuation). DOCUMENTS CONSIDERED TO BE RELEVANT

Category*	Citation of document, with indication, where appropriate, of the relevant passages	Relevant to claim No.
X	DE 72 38 928 U (HORST THIEL) 25 January 1973 (1973-01-25) figure 1 page 2, line 19 - page 3, line 20 -----	1,6,7, 13,14
X	DE 89 06 253 U1 (WAREMA RENKHOFF GMBH & CO KG) 17 August 1989 (1989-08-17) figures 1,2 page 4, line 34 - page 6, line 14 -----	1,14
Y	EP 2 551 187 A1 (MITSUBISHI HEAVY IND LTD [JP]; YAMAMOTO KAZUO [JP]) 30 January 2013 (2013-01-30) figure 3 paragraphs [0032] - [0033] -----	3,4, 15-20
Y	US 5 082 409 A (BIAS DONALD R [US]) 21 January 1992 (1992-01-21) figures 1,3,5A,5B column 5, lines 23-44 -----	5,7-10
Y	WO 2009/063063 A1 (AIRBUS ESPANA SL [ES]; MARTIN HERNANDEZ AGUSTIN MARIA [ES]) 22 May 2009 (2009-05-22) figures 1,3 page 3, line 34 - page 4, line 4 -----	11,12
A	GB 2 163 817 A (ROCKWELL INTERNATIONAL CORP) 5 March 1986 (1986-03-05) figures 1-3 page 2, lines 79-82 -----	18

INTERNATIONAL SEARCH REPORT

Information on patent family members

International application No

PCT/GB2014/050169

Patent document cited in search report	Publication date	Publication date	Patent family member(s)	Publication date
DE 10148414	C1	06-03-2003	NONE	

US 4659273	A	21-04-1987	NONE	

EP 0040667	A1	02-12-1981	CA 1146385 A1	17-05-1983
			EP 0040667 A1	02-12-1981
			JP S5722411 A	05-02-1982
			US 4324516 A	13-04-1982

DE 7238928	U	25-01-1973	NONE	

DE 8906253	U1	17-08-1989	NONE	

EP 2551187	A1	30-01-2013	CA 2792105 A1	29-09-2011
			CN 102883949 A	16-01-2013
			EP 2551187 A1	30-01-2013
			JP 2011195114 A	06-10-2011
			US 2013043351 A1	21-02-2013
			WO 2011118558 A1	29-09-2011

US 5082409	A	21-01-1992	CA 2033618 A1	27-04-1992
			US 5082409 A	21-01-1992

WO 2009063063	A1	22-05-2009	EP 2219949 A1	25-08-2010
			ES 2342641 A1	09-07-2010
			US 2009128983 A1	21-05-2009
			WO 2009063063 A1	22-05-2009

GB 2163817	A	05-03-1986	NONE	
