

(No Model.)

C. S. BRADLEY.
DYNAMO ELECTRIC MACHINE OR MOTOR.

No. 522,286.

Patented July 3, 1894.

Fig. 1,

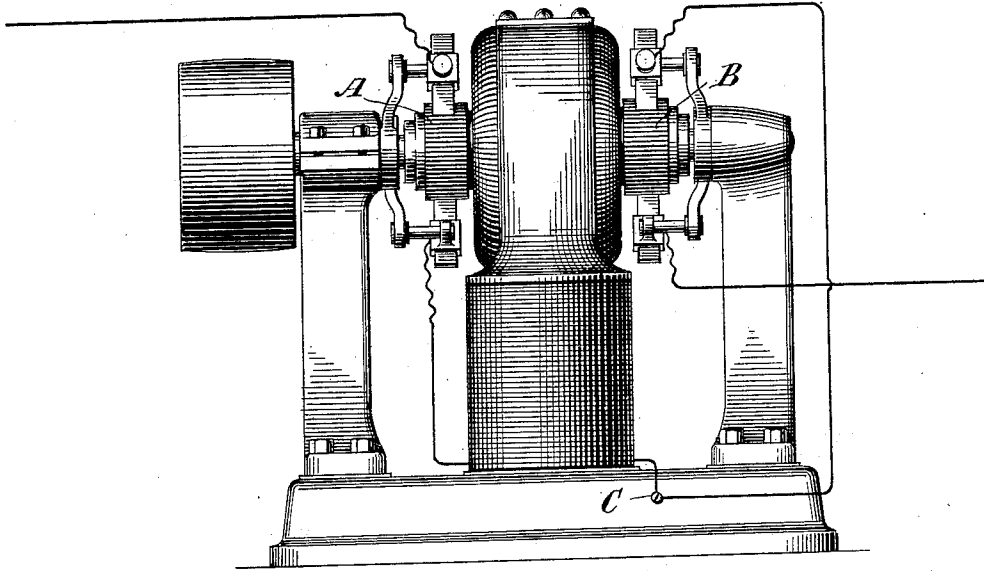
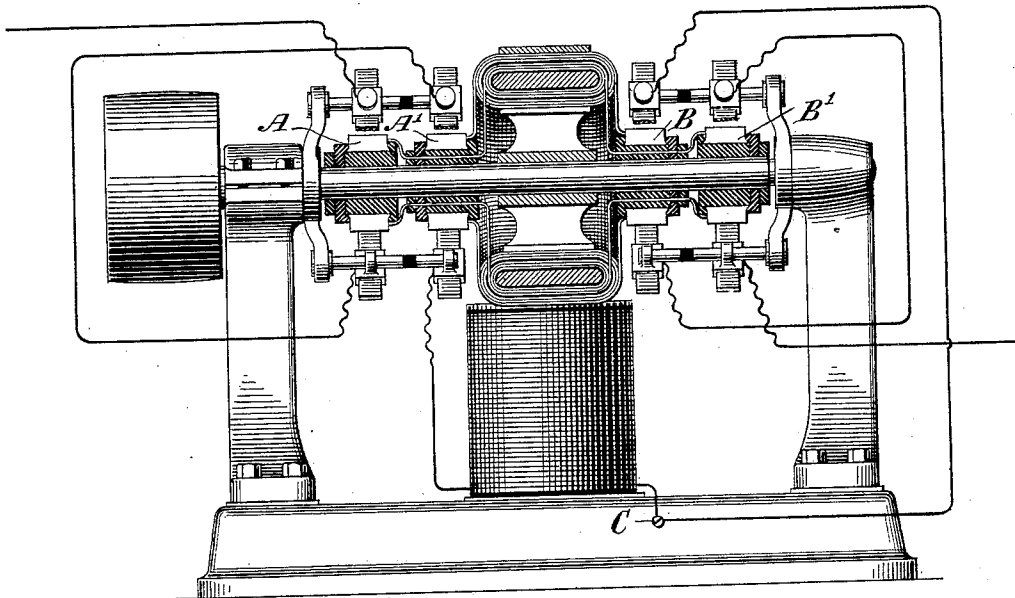

Fig. 2.



Witnesses
C. E. Ashley
John P. Nordstrom

Inventor
Charles S. Bradley
By his Attorney
Root & Head

UNITED STATES PATENT OFFICE.

CHARLES S. BRADLEY, OF AVON, NEW YORK.

DYNAMO-ELECTRIC MACHINE OR MOTOR.

SPECIFICATION forming part of Letters Patent No. 522,286, dated July 3, 1894.

Application filed October 26, 1893. Serial No. 489,158. (No model.)

To all whom it may concern:

Be it known that I, CHARLES S. BRADLEY, a citizen of the United States, residing in Avon, in the county of Livingston and State of New York, have invented certain new and useful Improvements in Dynamo-Electric Machines or Motors, of which the following is a specification.

This invention relates to high potential dynamo electric machines or motors of that kind in which the field-magnet circuit is coupled in series relation to the armature circuit. Machines of this character are commonly used, for example, in constant current systems, in arc lighting, and other applications, where the several translating devices used in the circuit are connected in series relation and high tension currents are needed. In such machines the high potential of the current carried by the insulated windings necessitates very perfect insulation of the latter, by reason of the great dielectric strain on the insulation; moreover, a very perfect degree of insulation is needed at the commutator.

It is the object of my improvements to render such machines safely operative without the necessity of adopting extraordinary precautions in the insulation.

In carrying out the invention I provide the machine with a plurality of armature windings coupled to independent pairs of brushes, and connect the field-magnet coil in series relation with a pair of intermediate brushes forming a good electrical connection at some point between the intermediate brushes and the base of the machine. The result of this construction is that the frame of the machine is brought to the potential of one of the intermediate brushes and the dielectric strain upon the field-magnet and armature circuits is greatly reduced.

In the accompanying drawings, which illustrate the invention, Figure 1 is a side elevation of a machine provided with a ring armature and two armature windings embodying my improvements, and Fig. 2 is a similar view, partly in section, of a similar machine having four armature windings.

The improvements are similar in character to those described in a patent issued to me August 22, 1893, No. 503,574, with additional

provisions for the protection of the field-magnet circuit.

Referring to Fig. 1, A and B represent the terminals of two independent armature circuits, in this case two independent commutators being provided. Independent pairs of brushes for each armature circuit are provided, and two brushes of opposite sign are connected together, including the field-magnet coil, and at some point of this intermediate connection, as, for example, at C, a good electrical connection is made with the frame of the machine. With this construction the frame of the machine will be at about half the potential of the highest potential in the circuit, and thus the dielectric strain upon the insulation of the armature will be but one-half of what it would be if the connection with the frame were not made. The field-magnet core being connected with the frame, the strain upon the insulation of the field-magnet windings will, at the greatest point, be only such as is due to the drop due to the coil resistance. A similar construction may be made, employing any desired number of pairs of brushes or commutators; for example, in Fig. 2, four independent armature circuits and four sets of brushes are employed. In such a case a point of the internal circuit near the field-magnet coil will preferably be provided with a base connection at C. Thus whatever potential may exist between the terminal brushes of the machine, the frame of the machine will be brought to about half that potential, and the dielectric strain upon the armature winding halved, whereas the strain upon the field-magnet winding will be still further reduced, since between the highest potential of the field-magnet circuit and the frame of the machine, only such difference can exist as is due to the drop between the terminals of the field-magnet circuit. From this construction it will be seen that if each armature winding develops five hundred volts, the two armature windings in Fig. 1 would develop one thousand volts, and the four windings in Fig. 2, two thousand volts, whereas the safety of the machine would be insured with a much lower degree of insulation than is ordinarily employed.

In mounting the machine care should be

taken to highly insulate it from earth, in order to prevent leakage from the base, which, under the system of connections described, will have considerable potential. Any suitable system of regulation may be employed,

5 and as such forms no part of my invention, it need not be herein described. Two or more pairs of brushes may, if desired, be mounted upon the same rocker frame, as illustrated in
 10 Fig. 2, care being taken that the several pairs of brushes are well insulated from one another.

Although a ring armature is shown in the drawings, it will be readily understood that
 15 the character of the magnetic circuit forms no limitation upon the applicability of the invention.

Having thus described my invention, what I claim as new, and desire to secure by Letters
 20 Patent, is—

1. A dynamo electric machine or motor having a plurality of armature circuits, independent commutator brushes for each circuit, and connections coupling the several pairs of

brushes in series relation, the connection between an intermediate pair of brushes including the field-magnet circuit, and being electrically connected with the frame.

2. A dynamo electric machine or motor having its field-magnet circuit in series relation to the armature circuit and provided with an electrical connection at a point intermediate of the terminals with the frame.

3. A dynamo electric machine or motor provided with a plurality of armature windings, independent pairs of brushes coupling said windings in series, a field-magnet coil in series relation to an intermediate pair of brushes, and an electrical connection between the frame and some point between the intermediate brushes.

In testimony whereof I have hereunto subscribed my name this 18th day of October, A. D. 1893.

CHARLES S. BRADLEY.

Witnesses:

ROBT. H. READ,
 E. C. GRIGG.