

H. M. ROCKEY.
Rain-Water Shut-Off.

No. 200,344.

Patented Feb. 12, 1878.

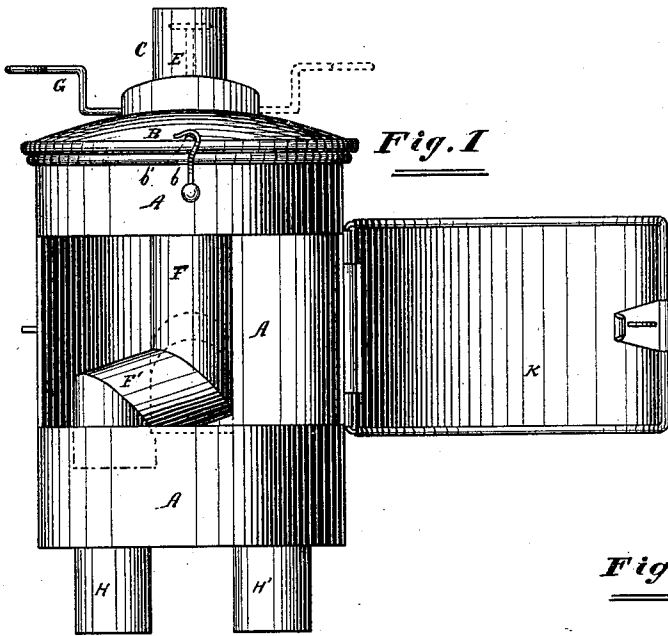

Fig. 1

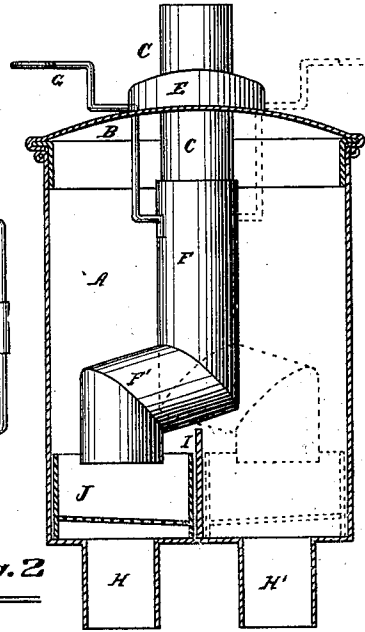

Fig. 2

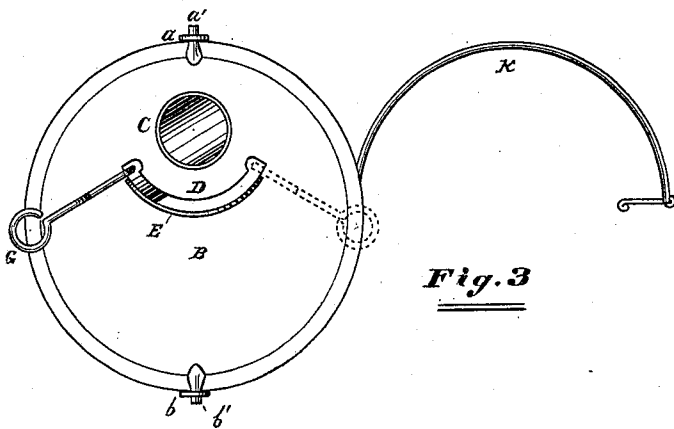

Fig. 3

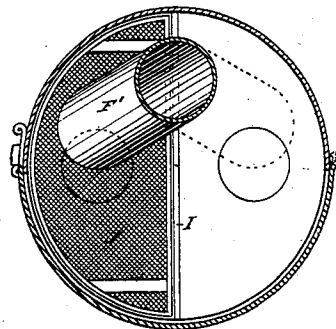

Fig. 4

Attest:

James A. Coyne
J. J. MacKellar

INVENTOR:

Henry M. Rocky
By *J. F. Warner* his
Attorney.

UNITED STATES PATENT OFFICE.

HENRY M. ROCKEY, OF ROCK GROVE, ILLINOIS.

IMPROVEMENT IN RAIN-WATER SHUT-OFFS.

Specification forming part of Letters Patent No. **200,344**, dated February 12, 1878; application filed November 6, 1877.

To all whom it may concern:

Be it known that I, HENRY M. ROCKEY, of Rock Grove, in the county of Stephenson and State of Illinois, have invented certain new and useful Improvements in Rain-Water Cut-Offs, of which the following is a full, clear, and exact description, which will enable others skilled in the art to which my invention appertains to make and use the said improvements, reference being had to the accompanying drawing, forming a part hereof, and in which—

Figure 1 is a front elevation of a rain-water cut-off and strainer embodying my invention; Fig. 2, a vertical central section thereof; Fig. 3, a top or plan view; and Fig. 4, a central cross-section.

Like letters of reference indicate like parts.

In the drawing, A represents the outer case or body of the cut-off attachment, and B is a removable top. The top may be fastened to the body in any suitable manner, preferably by means of the loop *a*, applied to the body, and arranged to receive the short horizontal pin or catch *a'*, applied to the top, the parts *a* and *a'* acting in conjunction with the hook *b* and the pin *b'*, the latter parts being applied to the body and top, respectively, and arranged opposite to the parts *a* and *a'*, as represented.

C is a pipe or tube, entering the top B, and adapted to receive the lower end of the spout depending from the eaves-troughs. D is a curved slot in the top B. This slot lies in a curved line having a center identical with that of the tube C, or nearly so.

E is a shoulder, parallel with the slot D, and having sloping or curved ends, as shown. F is a tube, into which the lower end of the tube C passes freely. The lower end of the tube F is vertical, but is connected to the upper part by means of the horizontal or nearly horizontal part F'.

G is a rod or handle, bent to rest upon the top C, and passing downward through the slot D. The lower end of the part G is attached to the upper part of the tube F.

H H' are tubes or spouts depending from the bottom of the part A, and I is a low wall or partition, separating the upper end or mouth of the tube H from that of the tube H'. The

lower part of the body A is thus divided into two like-formed compartments.

J is a strainer, arranged in one of the compartments last referred to. This strainer is removable, and may be placed in either compartment. Either the spout H or the spout H' may be connected with a tube or spout entering a cistern, and the other with a flue for conducting the water away from instead of into the cistern.

The roofs of buildings, as is well known, become dusty and dirty, especially in dry and windy weather. The first portion of the water which is shed by a roof during a rain is therefore dirty, and will, if it is allowed to enter a cistern, contaminate all the water therein. If the dust and dirt settles to the bottom of the cistern, in time it is liable to be sucked up and discharged by the pump, or again mixed with the water during a following shower. Various means have therefore been employed to keep the water of cisterns clean and pure at all times; and the object of my invention is to produce this result by means of the device now described.

The sieve should be arranged to receive the water discharged by the spout F. Both of the spouts H and H' may be connected with flues for conducting the water to cisterns—a part to one cistern and a part to another. When one of these pipes is connected to a mere waste-pipe, the sieve need not be arranged to keep back the floating particles in the water, unless there is danger of the pipes being choked by these foreign materials.

To shift the spout F so that it will discharge the water into one eduction or the other, it is only necessary to move the part G from one end of the slot D to the other. This act not only shifts the spout F, but lifts it over the wall I, for the part G, in being so moved, rides over the shoulder E.

K is the door in the case or body A.

It is obvious that the spout F should be set so that the water will not enter the cistern until the roof is washed, or at least will not until then enter the cistern, the contents of which are to be kept clean.

The device or attachment is simple in its construction and operation, and is cheap and

not liable to get out of order. Neither the sieve nor the shoulder E is absolutely essential; but I deem it preferable to employ them for the purposes above mentioned. The door K may also be omitted when the top B is removable; but I deem it best to use such a door, in order that access may be had to the interior of the part A without disconnecting the attachment from the water-spout on the building, and without removing the cover.

Having thus described my invention, what I claim as new, and desire to secure by Letters Patent, is—

1. The body or outer case, having in its top the fixed tube C and the slot D, and in its bottom the tubes H and H' and the dividing-wall I, in combination with the loose or rotary bent tube F, entered by the tube C, and suspended by the part G passing through the slot D, substantially as and for the purposes specified.

2. The body or case, having a top slotted, as at E, and provided with the tube C and shoulder E, and a bottom provided with the tubes H and H' and the dividing-wall I, in combination with the loose bent tube F and part G, substantially as and for the purposes specified.

3. The body A, provided with the door K and slotted top B, having therein the tube C, the wall I, the discharge-tubes H and H', the adjustable tube F, and the shifting-rod G, all combined substantially as and for the purposes specified.

HENRY M. ROCKEY.

Witnesses:

H. O. FRANKEBERGER,
CURRILLA J. FRANKEBERGER.