



(11) **EP 1 779 980 A3**

(12) **EUROPEAN PATENT APPLICATION**

(88) Date of publication A3:  
**08.01.2014 Bulletin 2014/02**

(51) Int Cl.:  
**B25D 17/24** <sup>(2006.01)</sup> **B25D 17/06** <sup>(2006.01)</sup>  
**B23B 51/04** <sup>(2006.01)</sup>

(43) Date of publication A2:  
**02.05.2007 Bulletin 2007/18**

(21) Application number: **07102225.5**

(22) Date of filing: **19.03.2004**

(84) Designated Contracting States:  
**AT BE BG CH CY CZ DE DK EE ES FI FR GB GR HU IE IT LI LU MC NL PL PT RO SE SI SK TR**

(72) Inventors:  
• **Stirm, Michael**  
**65503, Idstein (DE)**  
• **Faatz, Heinz-Werner**  
**65503, Idstein (DE)**

(30) Priority: **21.03.2003 PCT/GB03/06525**  
**11.10.2003 PCT/GB03/23885**

(74) Representative: **Bell, Ian Stephen et al**  
**Black & Decker**  
**Patent Department**  
**210 Bath Road**  
**Slough**  
**Berkshire SL1 3YD (GB)**

(62) Document number(s) of the earlier application(s) in accordance with Art. 76 EPC:  
**06117029.6 / 1 710 052**  
**04721875.5 / 1 606 082**

(71) Applicant: **Black & Decker, Inc.**  
**Newark, DE 19711 (US)**

(54) **Vibration reduction apparatus for power tool and power tool incorporating such apparatus**

(57) A vibration reduction apparatus 501 for use with a hammer tool having a hammer piston 520 is shown. The hammer piston 520 is caused to reciprocate in cylinder 530 by rotation of a gear wheel 523 about axis 524, the hammer piston 520 being mounted to the gear wheel 523 via piston arm 531 and pivot pin 522. Reciprocating motion of the hammer piston causes a flying mass 569 to be driven along cylinder 530 to impart a hammer action to a bit of the tool. The gear wheel 523 is caused to rotate about axis 524 by meshing of gear 514 on drive shaft 511 with gear teeth 532 on the periphery of gear wheel 523, the drive shaft 511 being caused to rotate by a motor (not shown) of the tool. a cam 533 is rigidly mounted around gear wheel 523, a counterweight 521 surrounds piston cylinder 530, and a cam follower 534 is provided on counterweight 521. The cam follower 534 on counterweight 521 is urged into contact with cam 533 by means of a compression spring 535. The external profile of the cam 533 is such that rotation of gear wheel 534 cause reciprocating motion of hammer piston 520 causes oscillation of counterweight 521 relative to piston cylinder 530 in antiphase to motion of the hammer piston 520 to counteract vibrations produced by operation of the hammer action of the tool..

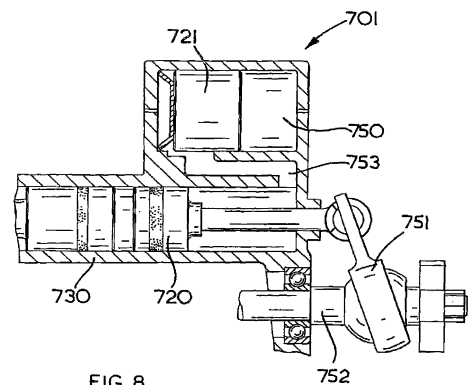

FIG. 8



EUROPEAN SEARCH REPORT

Application Number  
EP 07 10 2225

DOCUMENTS CONSIDERED TO BE RELEVANT			
Category	Citation of document with indication, where appropriate, of relevant passages	Relevant to claim	CLASSIFICATION OF THE APPLICATION (IPC)
X	DE 87 08 167 U1 (BOSCH) 13 October 1988 (1988-10-13)	1-5	INV. B25D17/24 B25D17/06 B23B51/04
A	* page 3 - page 3; figures * -----	6	
X	US 3 028 841 A (CHARLES LEAVELL) 10 April 1962 (1962-04-10) * figures * -----	1	
			TECHNICAL FIELDS SEARCHED (IPC)
			B25D B23B
The present search report has been drawn up for all claims			
Place of search The Hague		Date of completion of the search 28 November 2013	Examiner Rabolini, Marco
CATEGORY OF CITED DOCUMENTS		T : theory or principle underlying the invention E : earlier patent document, but published on, or after the filing date D : document cited in the application L : document cited for other reasons ..... & : member of the same patent family, corresponding document	
X : particularly relevant if taken alone Y : particularly relevant if combined with another document of the same category A : technological background O : non-written disclosure P : intermediate document			

3  
EPO FORM 1503 03.82 (P04C01)

**ANNEX TO THE EUROPEAN SEARCH REPORT  
ON EUROPEAN PATENT APPLICATION NO.**

EP 07 10 2225

This annex lists the patent family members relating to the patent documents cited in the above-mentioned European search report. The members are as contained in the European Patent Office EDP file on  
The European Patent Office is in no way liable for these particulars which are merely given for the purpose of information.

28-11-2013

Patent document cited in search report		Publication date	Patent family member(s)	Publication date
DE 8708167	U1	13-10-1988	NONE	
-----				
US 3028841	A	10-04-1962	DE 1197040 B	15-07-1965
			DE 1239249 B	20-04-1967
			FR 1334347 A	09-08-1963
			GB 927902 A	06-06-1963
			GB 927903 A	06-06-1963
			US 3028841 A	10-04-1962
-----				

EPO FORM P0459

For more details about this annex : see Official Journal of the European Patent Office, No. 12/82