

(12) UK Patent Application (19) GB (11) 2554215 (13) A

(43) Date of Reproduction by UK Office 28.03.2018

(21) Application No: 1716460.9  
(22) Date of Filing: 28.04.2016  
Date Lodged: 09.10.2017  
(30) Priority Data:  
(31) 62165763 (32) 22.05.2015 (33) US  
(86) International Application Data:  
PCT/US2016/029755 En 28.04.2016  
(87) International Publication Data:  
WO2016/191029 En 01.12.2016

(51) INT CL:  
E21B 47/00 (2012.01)  
(56) Documents Cited:  
US 6856936 B1 US 6470749 B1  
US 5995447 A US 20110096629 A1  
US 20060198243 A1  
(58) Field of Search:  
INT CL E21B, G01N, G01R, G01S, G01V, H04B  
Other: eKOMPASS (KIPO internal)

(71) Applicant(s):  
Halliburton Energy Services, Inc.  
(Incorporated in USA - Texas)  
3000 North Sam Houston Parkway East, Houston,  
Texas 77032, United States of America  
(72) Inventor(s):  
Batakrishna Mandal  
Yinghui Lu  
(74) Agent and/or Address for Service:  
Withers & Rogers LLP  
4 More London Riverside, LONDON, SE1 2AU,  
United Kingdom

(54) Title of the Invention: Real-time adaptative minimum phase wavelet generation for downhole tools  
Abstract Title: Real-time adaptative minimum phase wavelet generation for downhole tools

(57) An example method may include selecting a proposed pulse. A minimum phase wavelet may be generated based, at least in part, on the proposed pulse. A pulse signal within a wellbore may be generated based, at least in part, on the minimum phase wavelet. An echo signal corresponding to the pulse signal from at least a portion of the wellbore may be received, wherein the echo signal is indicative of a wellbore property

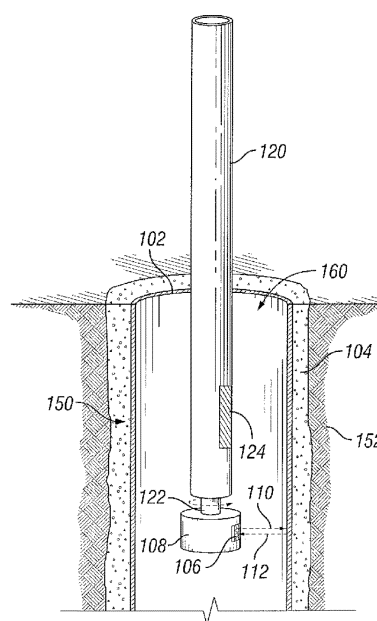

FIG. 1

GB 2554215 A