

(No Model.)

E. N. McPHERRON.

NEEDLE THREADER FOR SEWING MACHINES.

No. 303,030.

Patented Aug. 5, 1884.

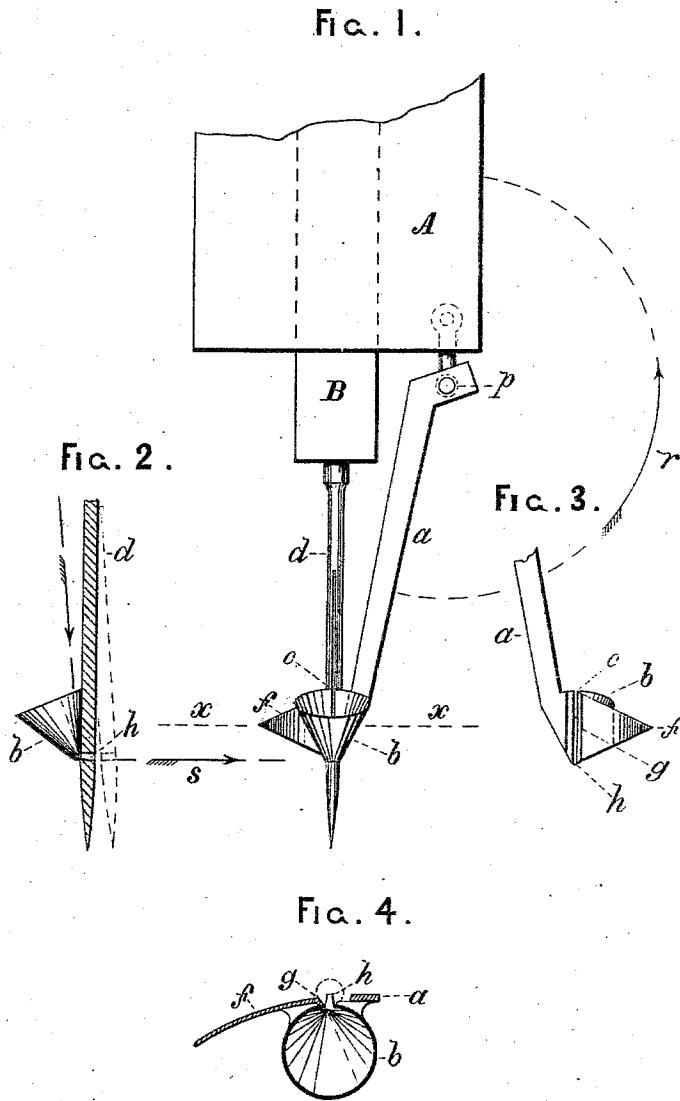

WITNESSES .

R. Newton.

A. Hamilton.

INVENTOR .

Edwin N. McPherron.

By J. S. Davenport Atty.

UNITED STATES PATENT OFFICE.

EDWIN N. MCPHERRON, OF GREENFIELD, ILLINOIS.

NEEDLE-THREADER FOR SEWING-MACHINES.

SPECIFICATION forming part of Letters Patent No. 303,030, dated August 5, 1884.

Application filed November 16, 1883. (No model.)

To all whom it may concern:

Be it known that I, EDWIN N. MCPHERRON, of Greenfield, in the county of Greene and State of Illinois, have invented a new and Improved Needle-Threader for Sewing-Machines; and I do hereby declare that the following is a full and exact description of the same, reference being had to the accompanying drawings and to the letters of reference marked thereon.

My invention relates to an improvement in needle-threaders for sewing-machines, the object of the same being to provide a conical thread-guide of simple construction adapted to be closed and opened by the needle itself.

A further object of my invention is to provide the threader with a stop adapted to abut against the side of the needle, of such form as to insure coincidence of the axis of the needle with the center of the opening in the wall of the conical thread-guide.

A still further object of my invention is to provide means for preventing the fibrous end of the thread, while being passed into the eye of the needle, from catching upon the lower edge thereof.

These improvements I accomplish by certain details of construction and combinations of parts, fully explained hereinafter.

In the accompanying drawings, Figure 1 is a front elevation of my device, showing a portion of the needle-bar and the head of the machine, in which it slides, with such other parts as necessarily co-operate with the device. Fig. 2 is a side sectional elevation of the same, taken in the line of the axis of the needle, exhibiting the lower portion of the latter in connection with the threader. Fig. 3 is a rear view of the threader without the needle. Fig. 4 is a sectional plan view taken in the line x , Fig. 1, enlarged.

In Fig. 1, A represents a portion of the sewing-machine head, in which the needle-bar slides.

B represents the needle-bar, and a the arm of the threader, pivoted upon an axis, p , which is secured to the lower rear part of the head A in such position as to allow the arm a to swing round through half a revolution into the position indicated by the arrow r .

To the lower extremity of the arm a is se-

cured, in the position shown in the drawings, a funnel-shaped thread-guide, b , the small orifice of which is adapted to coincide with the eye of the needle, said orifice being a continuation of the narrow slot c in the vertical wall of the thread-guide b , the said slot c being adapted to receive and be closed by the needle, the funnel-shaped guide being so adjusted upon the supporting-arm a as to press lightly upon the side of the needle.

To the rear of the thread-guide b is secured a curved plate, f , the general contour of which will be understood by reference to Figs. 3 and 4. The office of this curved plate is to push aside the needle as the threader-arm a is turned down into position for threading, the rear edge, g , being adapted to impinge upon the side of the needle by the reaction of a spiral spring upon the axis p , which, though co-operating with my invention, forms no part thereof, the only feature of novelty in connection with the curved plate here referred to being the peculiar bevel given to the edge that abuts against the side of the needle, so as to adapt it, as hereinafter explained, to needles of different sizes, in such manner as to always bring the groove in the side of the needle, as well as the eye, to the center of the slot c .

By reference to Fig. 2 it will be noticed that the thread-guide b is provided with a very small tongue of metal, h , beneath the orifice therein, said tongue being adapted to project within the eye of the needle at the lower part thereof, thus forming a continuation of the wall of the thread-guide into the interior of the eye of the needle. The object of this contrivance is to prevent the possibility of the fibrous end of the thread catching upon the lower edge of the entrance to the needle-eye.

The operation of my device is as follows: The threader being turned up against the side of the head of the machine, as indicated by the arrow r , it is turned down against the resistance of the spiral spring upon the axis p , the curved plate f being so formed as to spring aside the needle until the edge g is passed, when, by its reactionary force, it falls into the slot c , being at the same time held by the reaction of the spiral spring upon the axis p against the beveled edge g of the plate f , the said edge g being beveled at such an angle that

whatever the size of the needle the groove therein shall be brought to the center of the slot *c*. Matters being thus, the end of the thread is passed into the thread-guide, by which it is conducted through the eye of the needle. Being then taken hold of between the thumb and forefinger, it is drawn tight horizontally, as indicated by the arrow *s*. The effect of this latter action is to spring the needle aside from the edge or shoulder *g* of the plate *f*, as indicated in dotted lines in Fig. 2, when the threader instantly flies back by the reaction of the spring upon the axis *p* into the position indicated by the arrow *r*.

As a matter of preference the conical thread-guide is attached to the arm *a* in an almost vertical position, so as to facilitate the operation of threading, which is usually accomplished by a downward rather than a horizontal movement.

The device here presented having some of the features of one of my former inventions, consisting of an improvement in needle-threaders for sewing-machines, filed June 21, 1883, allowed September 4, 1883, Serial No. 98,767, incorporated into it, I do not claim all that is here shown and described.

What I do claim, however, and desire to secure by Letters Patent, is—

A needle-threader for sewing-machines in which are combined a conical thread-guide, pivoted by an arm, *a*, to the head *A* of the machine, and provided with a slot, *c*, which is adapted, when in position for threading, to be closed by the grooved side of the needle, a tongue, *h*, projecting from the lower edge of the orifice of the conical thread-guide, adapted to enter the lower part of the eye of the needle for the purpose of preventing the end of the thread, when presented to the entrance of the eye, from catching upon the lower edge thereof, and the curved plate *f*, provided with a beveled needle rest or stop, *g*, all of said parts being formed and combined as and for the purpose herein set forth.

In testimony that I claim the foregoing I have hereunto set my hand this 31st day of October, 1883.

EDWIN N. McPHERRON.

Witnesses:

NEWTON GRAY,
I. HOWARD GRAY.