

19



LE GOUVERNEMENT
DU GRAND-DUCHÉ DE LUXEMBOURG
Ministère de l'Économie

11

N° de publication :

LU100853

12

BREVET D'INVENTION**B1**

21

N° de dépôt: LU100853

51

Int. Cl.:
H04M 1/72, H04B 1/18

22

Date de dépôt: 10/07/2018

30

Priorité:

72

Inventeur(s):
XU Yideng – Chongqing (Chine)

43

Date de mise à disposition du public: 03/12/2018

74

Mandataire(s):
ZHAOffice SPRL – 5030 GEMBLOUX (Belgique)

47

Date de délivrance: 03/12/2018

73

Titulaire(s):
Chongqing Jiangjin DuoYanTang Network Technology
Co., Ltd. – Chongqing (Chine)

54

SMART WEARABLE DEVICE.

57

The present invention relates to the field of smart devices, and in particular, to a smart wearable device. The smart wearable device includes a body and a spring bar, wherein the two ends of the body each are provided with a connecting portion, the connecting portion includes a first connecting end and a second connecting end which are disposed opposite to each other, and a laser direct structuring (LDS) antenna layer connected with a main circuit board in the body is disposed on the inner side of the first connecting end; the spring bar is disposed between the first connecting end and the second connecting end and includes a bar body; a contact edge is disposed at one end of the bar body, and the contact edge is in contact with the LDS antenna layer to form an antenna extension portion. The spring bar is connected with the LDS antenna layer disposed on the body of the smart wearable device, so that the spring bar becomes part of the LDS antenna layer, and the requirements for a high gain antenna are met without increasing the size of the product.

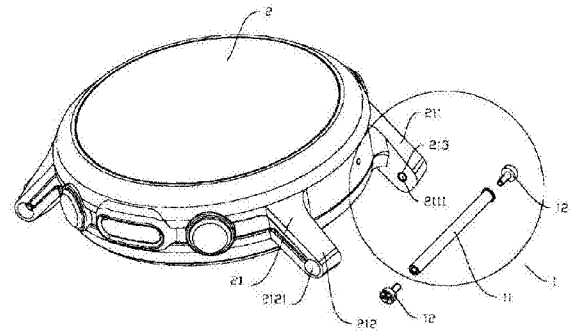

FIG. 1

BACKGROUND

5 **Technical Field**

The present invention relates to the field of smart devices, and in particular, to a smart wearable device.

Related Art

10 With the development of science and technology, more and more products have become intelligent, convenient, and highly integrated. Wearable smart devices, such as smart watches and wristbands, are increasingly becoming indispensable products in modern life.

The gain of an antenna and the size of the product form a contradiction. For a 15 wearable device, such as smart watch or wristband, in order to meet people's needs, it is necessary to limit the size of the product within a certain range to ensure that the product is light and easy to carry, and better signal strength is also needed to ensure smooth communication.

20 **Summary**

Against the aforementioned shortcomings in the prior art, the objective of the present invention is to provide a smart wearable device.

In order to achieve the aforementioned objective, the following technical solution is adopted according to the present invention:

25 The smart wearable device including a body and a spring bar, wherein the two ends of the body each are provided with a connecting portion, the connecting portion includes a first connecting end and a second connecting end which are disposed opposite to each other, and a laser direct structuring (LDS) antenna layer is disposed on the inner side of the first connecting end; the spring bar is disposed 30 between the first connecting end and the second connecting end and includes a bar

body; a contact edge is disposed at one end of the bar body, and the contact edge^{LU100853} is in contact with the LDS antenna layer to form an antenna extension portion.

Preferably, the first connecting end and the second connecting end are provided with corresponding connecting holes.

5 Preferably, the spring bar also includes spring bar screws which pass through the connecting holes respectively and are connected with the two ends of the bar body.

Preferably, the smart wearable device also includes a wrist strap, and one end of the wrist strap passes through the spring bar.

10 Preferably, the smart wearable device is a smart watch.

Preferably, the smart wearable device is a smart wristband.

The beneficial technical effect of the present invention lies in that the spring bar is connected with the LDS antenna layer disposed on the body of the smart wearable device, so that the spring bar becomes part of the LDS antenna layer, and
15 the requirements for a high gain antenna are met without increasing the size of the product.

Brief Description of Drawings

FIG. 1 is a schematic breakdown structure diagram of a smart wearable device
20 according to an embodiment of the present invention;

FIG. 2 is an enlarged structural schematic diagram of a part I in FIG. 1;

FIG. 3 is a detailed structural schematic diagram of a spring bar; and

FIG. 4 is a structural schematic diagram of a smart watch embodiment of a smart wearable device according to the present invention.

25

Description of Embodiments

Embodiments of the present invention are described in detail below by combination with accompanying drawings, but the present invention can be implemented by multiple different modes limited and covered by the claims.

30 As shown in FIG. 1 to FIG. 3, a smart wearable device provided by an

embodiment of the present invention includes a body 2 and spring bars 1 LU100853
connected to the two ends of the body 2.

The two ends of the body 2 are provided with connecting portions 21 which are used for connecting the body 2 with the spring bars 1. The connecting portions 21
5 each are provided with a first connecting end 211 and a second connecting end 212 which are disposed opposite to each other, and a laser direct structuring (LDS) antenna layer 213 is disposed on the inner side of the first connecting end 211, namely one side of the first connecting end 211 towards the second connecting end 212. The LDS antenna layer 213 is connected with a main circuit board mounted in
10 the body 2. It can be understood that in other embodiments, the positions of the first connecting end 211 and the second connecting end 212 are interchangeable in the figures, and the LDS antenna layer 213 can be arranged at the position of any of the first connecting end 211 and the second connecting end 212. In addition, in the figures, only part of the structure of the LDS antenna layer 213 is illustrated.
15 Therefore, the shape and location of the LDS antenna layer in the figure should not be considered as a limitation of the present invention.

The two ends of each spring bar 1 are connected with the first connecting end 211 and the second connecting end 212 respectively. In the embodiment shown in the accompanying drawing, the spring bar 1 includes a bar body 11 and spring bar
20 screws 12. The bar body 11 is a conductor, and fixing grooves 111 recessed towards the inside of the bar body 11 are formed in the two ends of the bar body 11. The first connecting end 211 and the second connecting end 212 are provided with connecting holes 2111 and 2121 respectively, and the spring bar screws 12 penetrate into the fixing grooves 111 through the connecting holes 2111 and 2121.
25 The inner walls of the fixing grooves 111 are provided with threads matching the spring bar screws 12. When the spring bar screws penetrate into the fixing grooves 111, the bar body 11 can be fixed by screwing the spring bar screws 12 and the threads. A contact edge 112 flush with the end of the bar body 11 is formed on the bar body 11 outwards along the edge. When the bar body 11 is connected to the
30 body 1 through the spring bar screws 12, the contact edge 112 is in contact with the

LDS antenna layer 213.

The bar body made of a conductor material is in contact with the LDS antenna layer, so that the bar body becomes part of the LDS antenna layer and the requirements for high gain of an antenna can be met. At the same time, the contact edge at the end of the bar body can increase the area of contact between the bar body and the LDS antenna layer, so that the contact between the bar body and the LDS antenna layer is more reliable.

In embodiments shown in FIG. 1 to FIG. 3, the bar body 11 of the spring bar 1 is connected with the connecting portion 21 through the spring bar screws 12. In other embodiments, the spring bar 1 and the connecting portion 21 can also be connected with each other in other modes. For example, a spring is arranged in the bar body 11 of the spring bar 1. At the same time, the first connecting end 211 and the second connecting end 212 are provided with grooves, so that the bar body 11 is clamped into the connecting portion 21 through the spring.

FIG. 4 is a schematic diagram of a smart watch according to an embodiment of the present invention. In the figure, one end of a wrist strap 3 passes through the spring bar 1 and is connected with the body 2. It can be understood that the present invention can also use a smart wristband as an embodiment.

What are described above are merely preferred embodiments of the present invention and do not accordingly limit the patent scope of the present invention. Equivalent structures or equivalent process transformations which are performed by utilizing the specification and accompanying drawing contents of the present invention are directly or indirectly applied to other relevant technical fields and shall be included within the patent protection scope of the present invention in a similar way.

Revendications

1. Dispositif portable intelligent, comprenant :
 - 5 un corps (2), dans lequel les deux extrémités du corps (2) sont chacune munies d'une partie (21) de connexion, la partie (21) de connexion comprenant une première extrémité (211) de connexion et une seconde extrémité (212) de connexion qui sont opposées l'une à l'autre, et une couche d'antenne (213) de structuration directe par laser (LDS) connectée à une carte de circuit principale dans le corps (2) est disposée sur le côté intérieur de la première extrémité (211) de connexion ;
 - 10 une barrette à ressort (1), qui est disposée entre la première extrémité (211) de connexion et la seconde extrémité (212) de connexion et qui comprend un corps (11) de barre, dans lequel un bord (112) de contact est disposé à une extrémité du corps (11) de barre, et le bord (112) de contact étant en contact avec la couche d'antenne (213) LDS afin de former une partie d'extension d'antenne.
- 15 2. Dispositif portable intelligent selon la revendication 1, dans lequel la première extrémité (211) de connexion et la seconde extrémité (212) de connexion sont munies d'orifices (2111, 2121) de connexion correspondants.
3. Dispositif portable intelligent selon la revendication 2, dans lequel la barrette à ressort (1) comprend également des vis (12) de barrette à ressort qui traversent
20 respectivement les orifices (2111, 2121) de connexion, et sont reliées aux deux extrémités du corps (12) de barre.
4. Dispositif portable intelligent selon la revendication 1, dans lequel le dispositif portable intelligent comprend également une dragonne (3) et une extrémité de la dragonne (3) passe à travers la barrette à ressort (1).
- 25 5. Dispositif portable intelligent selon la revendication 2, dans lequel le dispositif portable intelligent est une montre intelligente.
6. Dispositif portable intelligent selon la revendication 2, dans lequel le dispositif portable intelligent est un bracelet intelligent.

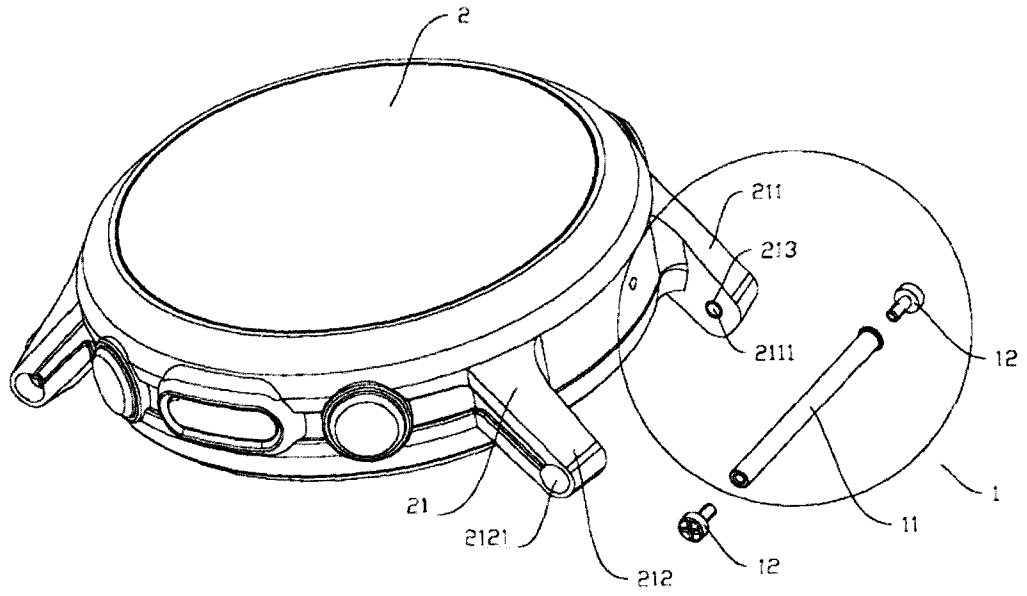

FIG. 1

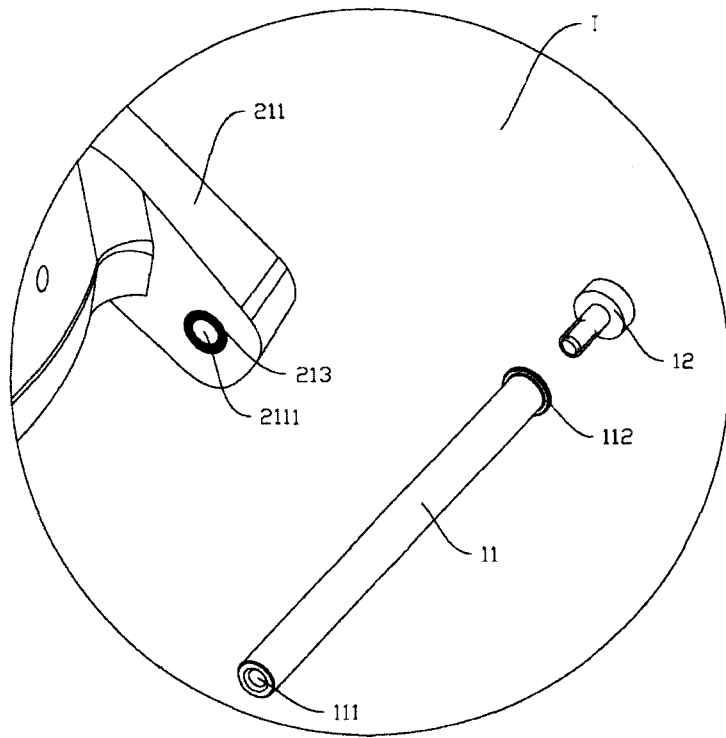

FIG. 2

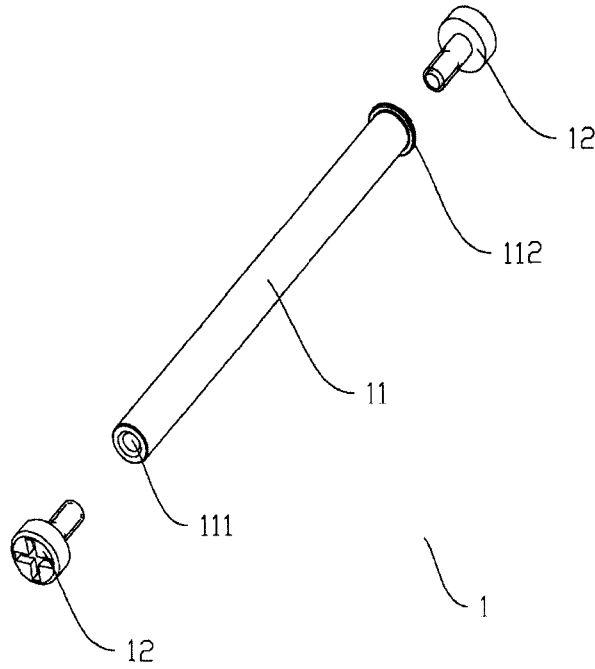

FIG. 3

9

LU100853

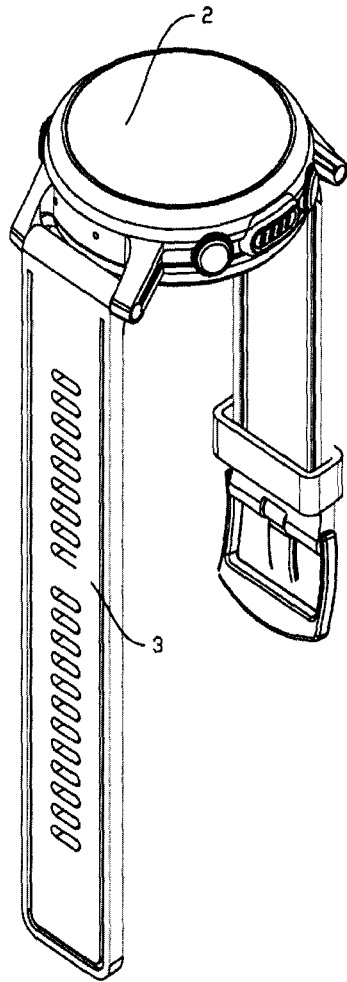

FIG. 4

ABSTRACT

LU100853

SMART WEARABLE DEVICE

5 The present invention relates to the field of smart devices, and in particular, to
a smart wearable device. The smart wearable device includes a body and a spring
bar, wherein the two ends of the body each are provided with a connecting portion,
the connecting portion includes a first connecting end and a second connecting end
which are disposed opposite to each other, and a laser direct structuring (LDS)
10 antenna layer connected with a main circuit board in the body is disposed on the
inner side of the first connecting end; the spring bar is disposed between the first
connecting end and the second connecting end and includes a bar body; a contact
edge is disposed at one end of the bar body, and the contact edge is in contact with
the LDS antenna layer to form an antenna extension portion. The spring bar is
15 connected with the LDS antenna layer disposed on the body of the smart wearable
device, so that the spring bar becomes part of the LDS antenna layer, and the
requirements for a high gain antenna are met without increasing the size of the
product.

20 Fig 1.