

(No Model.)

2 Sheets—Sheet 1.

G. W. PRICE. ENGINE.

No. 324,592.

Patented Aug. 18, 1885.

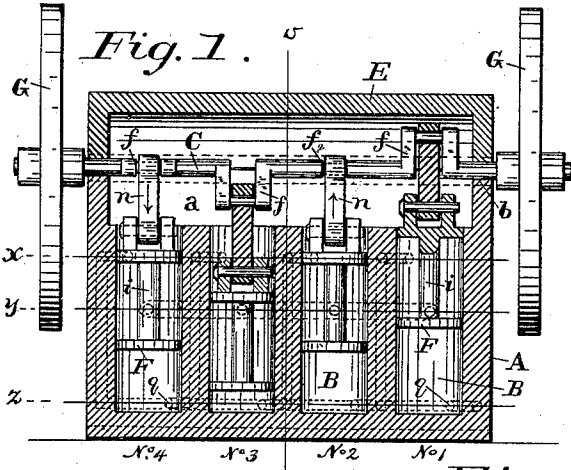

Fig. 1.

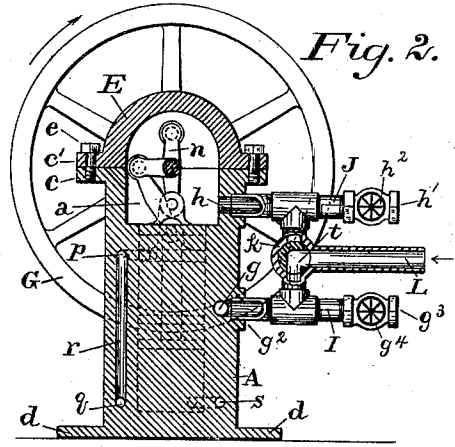

Fig. 2.

Fig. 3.

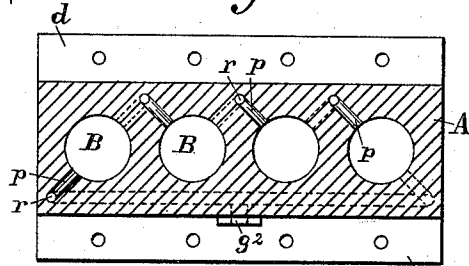

Fig. 4.

Fig. 7.

Fig. 6.

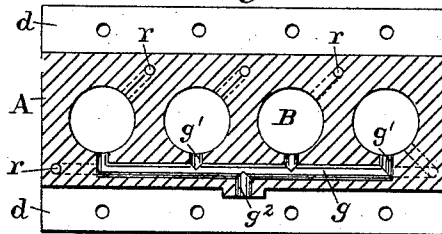
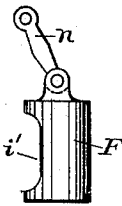
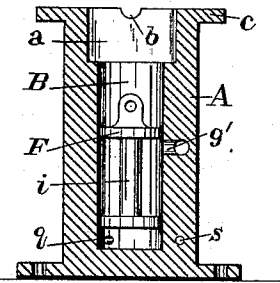

Fig. 5.



WITNESSES:

Edward A. Osse,
John E. Morris.

INVENTOR:

GEORGE W. PRICE,

By Chas B. Mann

Attorney.

(No Model.)

2 Sheets—Sheet 2.

G. W. PRICE. ENGINE.

No. 324,592.

Patented Aug. 18, 1885.

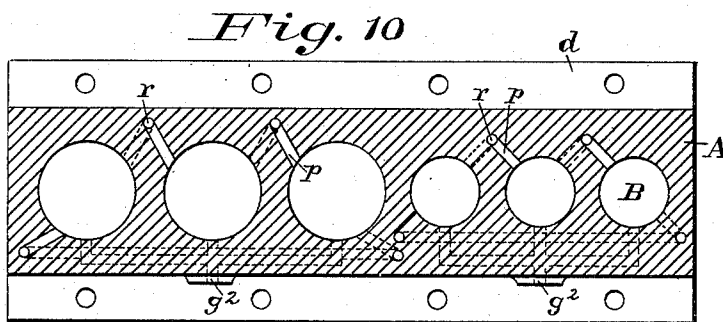
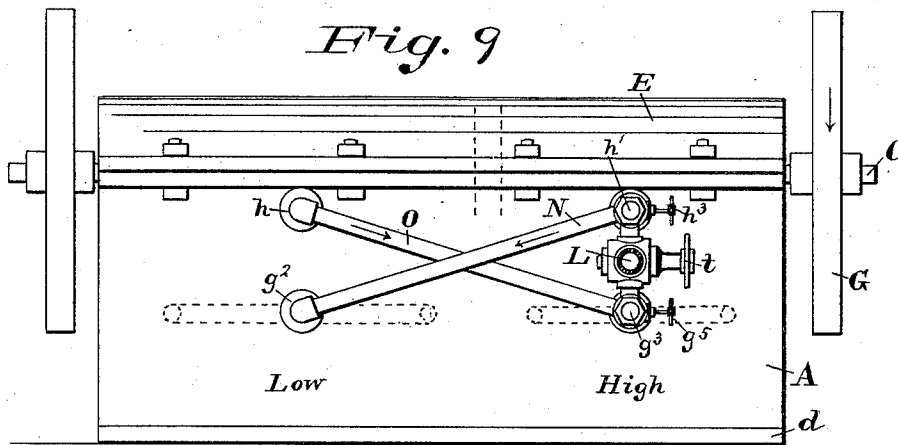
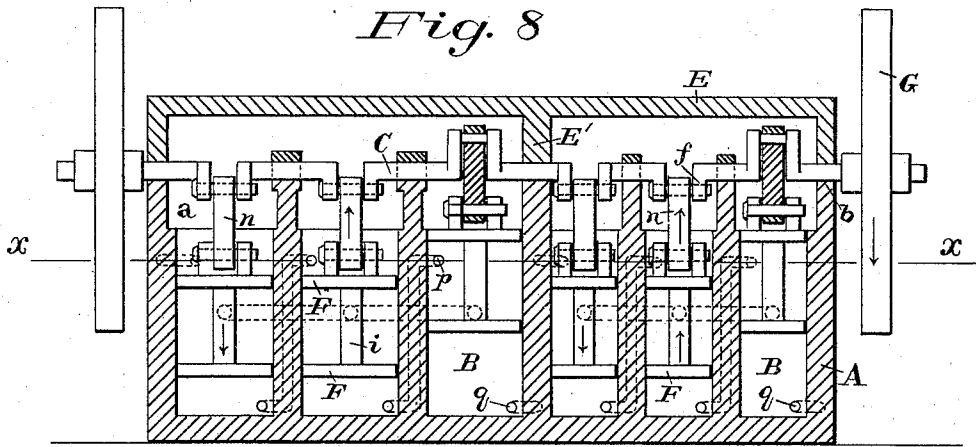

Fig. 11

WITNESSES:

Edward A. Osse,

John E. Morris

INVENTOR:

GEORGE W. PRICE,

By Chas B. Mann

Attorney.

UNITED STATES PATENT OFFICE.

GEORGE W. PRICE, OF BALTIMORE, MARYLAND, ASSIGNOR OF ONE-HALF TO
WILLIAM J. HOOPER, OF SAME PLACE.

ENGINE.

SPECIFICATION forming part of Letters Patent No. 324,592, dated August 18, 1885.

Application filed September 17, 1884. (No model.)

To all whom it may concern:

Be it known that I, GEORGE W. PRICE, a citizen of the United States, residing at Baltimore, in the State of Maryland, have invented certain new and useful Improvements in Engines, of which the following is a specification.

My invention relates to an improved engine of that class which use several cylinders provided with pistons, and as many cranks attached to a common shaft.

The engine is designed to be worked by steam, air, water, or any other fluid under pressure.

The accompanying drawings illustrate the invention, Figure 1 being a vertical longitudinal section of the engine; Fig. 2, a vertical cross-section of the same on the line *w*; Fig. 3, a horizontal section of the cylinders on the line *x*; Fig. 4, a horizontal section of the cylinders on the line *y*; Fig. 5, a horizontal section of the cylinders on the line *z*. Fig. 6 is a view showing another form of piston that may be employed. Fig. 7 is a vertical cross-section through one of the cylinders, showing the ports and the piston. Fig. 8 is a vertical section, and Fig. 9 a side view, of my improvements arranged for a compound engine. Fig. 10 is a horizontal section of same on line *x*, Fig. 8. Fig. 11 is a side view of controlling-valve for compound engine.

A solid block of metal, *A*, has four parallel bores, *B*, each of which constitutes a cylinder. The top of the block has a cavity, *a*, which extends over all the bores or cylinders, and the top edge of the block at each end of the said cavity has a bearing, *b*, for the shaft *C*. The top edge is also provided with a flange, *c*. The bottom of the block has base-flanges *d*, by which it may be secured to a permanent position. A cap, *E*, has flanges *e*, and entirely covers the cavity *a* over the cylinders. The cap is secured to its position over the cavity by bolts *e*, which pass through the flanges *e e'*. The shaft *C* extends across the open ends of all the cylinders, and has four cranks, *f*, all having a different position, each one being at a right angle, or a relative angle of ninety degrees with respect to the one next to it. The shaft with all the cranks turn in the chest, which is formed by the cavity *a* and

cap *E*, as will be understood by reference to Figs. 1 and 2. A passage, *g*, extends in a direction crosswise and at one side of all the cylinders, and from this passage a supply-port, *g'*, enters the side of each cylinder at a point about midway of its ends. These supply-ports are never closed. An inlet, *g''*, at the side communicates with the cross passage *g*, and thereby all the cylinders may constantly take steam, water, compressed air, or other fluid under pressure. An exhaust port, *h*, in the side of the chest provides for the escape of the fluid. Each cylinder is fitted with a double piston—that is, the piston has two heads, *F*—which are spaced apart a distance equal to the stroke which the piston is to have plus the width of the supply-port *g'*, which latter opens between the two heads, and is never closed by the reciprocation of the heads. Thus the fluid under pressure enters the cylinder and fills the space or recess *i'* between the two heads. A rod, *i*, rigidly connects the two heads, and a pitman, *n*, connects them with one of the cranks *f*. Driving-pulleys *G* are mounted on the crank-shaft, and belts may lead from either pulley to any desired machinery. Each cylinder has a port, *p*, near its upper end, which, by the reciprocation of the piston, is alternately opened to the space between the two piston-heads and the chest above the cylinders. It also has a port, *q*, near the lower end, which is not closed by the movement of the piston. A vertical passage, *r*, connects the upper port, *p*, of one cylinder with the lower port, *q*, of the next adjoining cylinder, thereby, when the upper port, *p*, of one cylinder (No. 1, for instance) is open to the space between the two piston-heads, the fluid under pressure entering that cylinder will have direct access to the lowermost side of the piston in the next cylinder (No. 2) by way of the port *p*, vertical passage *r*, and port *q*.

The cylinders No. 1, 2, and 3 are connected, as just described; but cylinder No. 4 is connected with No. 1 by means of a horizontal passage, *s*, leading from the lower end of its vertical passage *r* to the lower port, *q*, of said cylinder No. 1.

It will be seen that each cylinder has a center port, *g'*, open at all times to allow fluid un-

der pressure to enter the space or recess i' between the two piston-heads, and that from this space the fluid may pass to the lowermost side of the piston in the next cylinder, and by acting thereon force the same up, causing the shaft c to partly turn, and through the medium of the cranks and pitmen altering the position of all the other pistons. When piston No. 2, for instance, shall have reached the limit of its upstroke, the upper port, p , in its cylinder will be open to the space or recess i' in the piston, and then the fluid entering the space or recess from center port, g' , may pass through port p to the next cylinder, (No. 3,) as just described.

Instead of employing a piston having two heads F to form the fluid space or recess into which the center port, g' , of the cylinder may be always open, the piston may have a single head provided, as shown in Fig. 6, with a fluid space or recess, i' , having a length in the direction of its stroke sufficient to keep the upper port, p , and the center port, g' , in communication as long as necessary.

Going back, now, to consider the operation of exhausting, it will be found that when No. 2 piston has passed the first half of its upstroke No. 1 piston will have commenced its downstroke and No. 4 piston will have passed the first half of its downstroke. Now, upon these pistons continuing their movement, that of No. 4 will open the upper port, p , to the chest, whereupon the fluid below the lowermost side of the piston in cylinder No. 1 may exhaust through its lower port, q , the horizontal passage s , and vertical passage r , and upper port, p , of cylinder No. 4. The upper ports, p , and lower ports, q , therefore serve alternately for the induction and exhaustion of the fluid. When the fluid below any piston is exhausted, it is delivered from a port, p , into the chest under the cap E , and from thence is exhausted through the port h .

It will be seen the cylinders are all parallel with each other, and have position in a straight line direct with the shaft; also, that the usual valves are dispensed with, and that there is no need for valve-gear.

When taking the supply of fluid under pressure, and exhausting, as above described, the shaft C will always be turned in one direction, as indicated by the arrow on Fig. 2; but the shaft may be turned in the reverse direction by using the port h as the supply-port and the port g^2 as the exhaust. To readily effect this reversal and provide for driving the shaft in either direction, a pipe, I , is connected with the inlet or port g^2 , and said pipe has an exhaust-outlet, g^3 , which is guarded by a valve, g^4 . The port h also has a pipe-connection, J , with an exhaust-outlet, h' , guarded by a valve, h^2 . The two pipes I and J have a connection, k , to which a fluid-supply pipe, L , attaches, and a two-way cock, t , at the junction of the supply-pipe and connection-pipe serves to direct the fluid under pressure, as desired, into either the port g^2 or the port h .

The cock t , therefore, is a controlling-valve, by turning which and adjusting the valves g^4 and h^2 the engine may be reversed.

Fig. 2 shows the controlling-valve in position to direct the fluid into the port g^2 . The outlets g^3 must therefore be closed and the outlet h' open to allow the fluid to exhaust.

In the construction here shown the metal block A is formed by casting, and the cylinders, as well as all the passages and ports, are cored in the casting; but they may be formed by boring, and the end of each bore-opening at the outside of the block closed by a plug, which is a construction readily understood by any skilled mechanic.

Instead of forming the cylinders and passages by coring or boring a metal block, it is obvious these parts may be made separately, the passages consisting of suitable pipes connected to the cylinders.

Three cylinders, and the same number of cranks, or any number greater than three, may be used with my improved arrangement of pistons, ports, and passages. When three are used, or in a compound steam-engine where six are used, the cranks must have a relative angle of one hundred and twenty degrees with respect to each other, the construction otherwise being the same as shown in Fig. 1.

In a multiple-cylinder engine of this kind there is no dead-center, and the pressure of fluid, while direct on one side only of each piston, is constant or continuous—that is, the pressure is always acting on a given side of one or more pistons. The engine will therefore run smoothly.

If the crank-shaft C in any given engine made on this plan was to be turned always in the same direction—that is, by taking the fluid, supply at the inlet-port g^2 —the cap E in such case could be dispensed with; but where it is desired to have the engine adapted for reversal the said cap is indispensable.

My improvements may be embodied in a steam-engine arranged for either high or low pressure, and in a compound engine, as shown in Figs. 8, 9, 10, and 11.

The arrangement of pistons, passages, and ports in the compound engine (see Figs. 8 and 10) will be readily understood from the foregoing description in connection with the following: The partition E' separates the two steam-chests. The high-pressure steam-chest, that above the small cylinders, is connected with the inlet-port g^2 of the low-pressure cylinders by an inclined pipe, N , one end of which is attached to the pipe J beyond the valve h^2 , and the other end to the said inlet-port. A second valve, h^3 , now becomes necessary in the pipe J to guard the outlet h' , and the first valve, h^2 , is employed when reversing the compound engine. In like manner the high-pressure port g^2 (which becomes the exhaust-port when the engine is reversed) is connected with the low-pressure steam-chest by an inclined pipe, O , one end of which is attached to the pipe I beyond the

valve g^4 and the other end to the exhaust-port h of the low-pressure chest. The two inclined pipes N and O pitch in opposite directions. A second valve, g^5 , is employed in the pipe I to guard the outlet g^3 .

The pistons, passages, and ports in the low-pressure part of the engine (the large cylinders) are constructed and arranged exactly as heretofore described.

10 The operation of the compound engine is as follows: When steam from the small cylinders exhausts into the high-pressure chest, it passes therefrom through the inclined pipe N to the inlet-port g^2 of the low-pressure cylinders, and exhausts from the low-pressure chest at h , passing through the inclined pipe O to the pipe I, and escapes at the outlet g^3 . (See Figs. 9 and 11.)

To reverse the engine, turn the controlling-cock t and the valves h^2 h^3 and g^4 and g^5 .

20 Having described my invention, I claim and desire to secure by Letters Patent of the United States—

1. An engine having in combination three or more cylinders, side by side and in a straight line with each other, each cylinder provided with a center port, g' , and at one end with a port, q , both of which always remain uncovered, and at the other end with a port, p , which is alternately opened and closed by the reciprocation of the piston, and with a piston having in its side a space or recess, v' , always in communication with the said center

port, a passage, g , extending crosswise of all the cylinders and connecting with each of the said center ports, a passage, r , connecting the port at one end of one cylinder with the port in the opposite end of the next adjoining cylinder, a shaft extending across the ends of all the cylinders and provided with cranks, and a pitman connecting each crank with a piston, as set forth.

2. An engine having in combination three or more cylinders, each provided at or about the center with a port, g' , at one end with a port, q , and at the other end with a port, p , and with a piston, a chest extending over the open ends of all the cylinders, a shaft having cranks f , which turn within the said chest, and each crank being connected with a piston, a pipe, I, in connection with the said center ports, g' , and having an exhaust-outlet, g^3 , guarded by a valve, a pipe, J, in connection with the steam-chest and having an exhaust-outlet, h' , guarded by a valve, and a fluid-supply pipe, L, connected with the said two pipes I and J, and provided with a controlling-valve, t , adapted to direct the fluid into either pipe, as set forth.

In testimony whereof I affix my signature in presence of two witnesses.

GEORGE W. PRICE.

Witnesses:

WM. B. NELSON,
JOHN E. MORRIS.