



(11) **EP 1 685 663 B1**

(12) **EUROPEAN PATENT SPECIFICATION**

(45) Date of publication and mention of the grant of the patent:
16.10.2013 Bulletin 2013/42

(21) Application number: **03778204.2**

(22) Date of filing: **01.12.2003**

(51) Int Cl.:
H04B 10/079 (2013.01)

(86) International application number:
PCT/CA2003/001874

(87) International publication number:
WO 2004/051889 (17.06.2004 Gazette 2004/25)

(54) **FLASH OPTICAL PERFORMANCE MONITOR**

OPTISCHES FLASH-LEISTUNGSÜBERWACHUNGSGERÄT

DISPOSITIF FLASH DE CONTROLE DES PERFORMANCES OPTIQUES

(84) Designated Contracting States:
AT BE BG CH CY CZ DE DK EE ES FI FR GB GR HU IE IT LI LU MC NL PT RO SE SI SK TR

(30) Priority: **29.11.2002 CA 2413218**

(43) Date of publication of application:
02.08.2006 Bulletin 2006/31

(73) Proprietor: **Measurement Microsystems A-Z Inc. Trois-Rivieres, Québec G9Z 4J4 (CA)**

(72) Inventors:
• **BARWICZ, Andrzej Trois-Rivieres, Québec G8Y 5W5 (CA)**

- **MORAWSKI, Roman PL-02-055 Warsaw (PL)**
- **LESUEUR, Sebastien Montreal, Québec H2P 1P8 (CA)**
- **MIEKINA, Andrzej PL-02-930 Warsaw (PL)**
- **OLESCZAK, Tomasz Trois-Rivieres, Québec G9A 2C1 (CA)**

(74) Representative: **Mintz Levin Cohn Ferris Glovsky and Popeo LLP Alder Castle 10 Noble Street London EC2V 7JX (GB)**

(56) References cited:
WO-A-00/71980 WO-A-01/52451

EP 1 685 663 B1

Note: Within nine months of the publication of the mention of the grant of the European patent in the European Patent Bulletin, any person may give notice to the European Patent Office of opposition to that patent, in accordance with the Implementing Regulations. Notice of opposition shall not be deemed to have been filed until the opposition fee has been paid. (Art. 99(1) European Patent Convention).

Description**Field of the Invention**

5 **[0001]** The present invention relates to the field of optical performance monitoring as currently applied in dense wavelength-division multiplexing.

Background of the Invention

10 **[0002]** The recent expansion of telecommunications and computer communications, especially in the area of the Internet, has created a dramatic increase in the volume of worldwide data traffic that has placed an increasing demand for communication networks providing increased bandwidth. To meet this demand, fiber-optic networks and dense wavelength-division multiplexing (DWDM) communication systems have been developed to provide high-capacity transmission of multi-carrier signals over a single optical fiber. In accordance with the DWDM technology, a plurality of superimposed concurrent optical signals is transmitted on a single fiber, each signal having a different central wavelength. In DWDM optical networks, optical transmitters and optical receivers are tuned to transmit and receive on a specific wavelength.

15 **[0003]** With the widespread deployment of DWDM optical networks, knowing precisely what is happening at the optical layer of the network is quickly becoming a real-time issue for network management. Stable and protected DWDM links cannot be realized without real-time optical monitoring at each channel. For example, as the number of channels deployed in a DWDM optical network increases, say from 40 to 80 or 160, wavelength drifts and power variations are more likely to cause data errors or transmission failures. It is therefore becoming important for network management to dynamically monitor the performance of the communication channels in order to supply the corresponding decision-support systems with information necessary for fault detection and identification, as well as for undertaking efficient restoration actions. To achieve this goal, a new type of fiber-optic products has been developed, the so-called optical performance monitors (OPM).

20 **[0004]** An OPM consists of a spectrometric transducer and a computing means. The spectrometric transducer converts an optical signal into a digital signal representative of the spectrum of the input optical signal. The computing means processes that digital signal in such a way as to provide the final result of measurement, i.e. an estimate of the parameters of the optical signal being monitored in a DWDM system. A fractional portion of optical power, typically 2%, is tapped from the mainstream optical signal running through the optical fibre, using a tap coupler. The purpose of tapping is monitoring the optical signal while keeping the properties of the main traffic unchanged. Since the tapped signal will not be added back to the mainstream signal, there is little effect on the properties of the transmitted data, and the OPM thus provides an almost non-invasive measurement. The weak signal tapped from the mainstream optical signal is then directed to an optical unit, by which the channelized wavelength components are separated. The optical unit therefore performs a spectral decomposition of the optical signal; the results of that decomposition are detected by a detector. The detector converts optical signals into electrical signals. The electrical signals are transmitted to the electronics circuitry for processing and digital output.

25 **[0005]** The principle of operation of a spectrometric transducer may refer to various physical phenomena that make possible separation of spectral components of the input optical signal. The following devices are examples of technical means used for this purpose:

- a grating or a linear variable filter that enables separation of spectral components in space;
- a tunable filter that enables separation of spectral components in time;
- 35 - an optical heterodyne that enables shifting the spectrum in a wavelength range where its analysis is easier.

40 **[0006]** A conventional optical network performance monitor typically contains a detection element that is responsive to the combination of all signal channels carried by a main signal stream, and that is operative to generate data containing information of a collective power level provided by all channels. Such data generated in the electrical domain are not sufficient to provide detailed information of channel performance. For instance, if a power level of one of a plurality of channels of the mainstream signal is decreased while a power level of another channel is increased, a total power level measured by such device typically remains constant, thereby providing an inaccurate indication of a monitored network performance. Thus, in order to monitor a condition of an individual channel in a DWDM network, performance monitoring is preferably carried out in the optical layer. An OPM constitutes an integrated spectrometric device at a module level operating in the optical layer, the device which is capable of monitoring the performance of all individual channels, and of providing rapid channel identification, i.e. the estimates of power (P), central wavelength (λ), and optical signal-to-noise ratio (OSNR) for each channel. In order to respond to higher channel counts and transmission speed, the efforts of improving the performance of OPM have been often focused on enhancing the performance of the optical part of the

spectrometric transducer which in turn resulted in a high design complexity and high manufacturing risks.

[0007] Following an RHK report ("Vendors Must Adapt Products, Strategies to Stake a Claim in Crowded OPM Market", Insight, January 2002), OPMs may be classified into three groups: Type-I OPMs, Type-II OPMs, and Type-III OPMs. A Type-I OPM is a monitor capable of providing real-time measurements of power for each DWDM channel. A Type-II OPM is a monitor capable of providing real-time measurements of power, central wavelength, and optical signal-to-noise ratio for each channel. A Type-III OPM is able, moreover, to predict indicators of the service quality provided by a DWDM system such as the bit-error rate (BER) and Q-factor (Q). Currently, those indicators can be correctly measured only with out-of-service test equipment, using a known test sequence in place of the real signal. The determination of BER and Q therefore takes place in the electrical domain, after a signal received by the DWDM receiver is passed on to the electronic circuit. Obviously, this is an expensive, time-consuming and cumbersome method.

[0008] The Type-I OPM commonly uses demultiplexing-type spectrometric transducers. Since a demultiplexing-type component, e.g. an AWG, gives a set of fixed discrete channels with a pre-defined frequency interval, i.e. channel spacing, such OPM is only able to provide power measurements at the wavelength positions corresponding to the DWDM channels. It is obvious that the measurements will be biased when there is thermal drift of some wavelength-related properties of the optical part of the OPM. A type-II OPM is able to provide more network information than a type-I OPM since it not only measures power, but also wavelength variation and OSNR.

[0009] It is not only P , λ , and OSNR of each channel that is of interest of in-service monitoring of a DWDM system, but also the bit error rate, BER, and Q, an indicator of overall quality of the signal. The conventional approach in determining BER makes use of out-of-service test equipment, and is time consuming and expensive. An obvious approach to in-service BER or Q reporting is an electrical-domain approach. It consists of tapping off a part of an optical signal, demultiplexing it through a tunable filter, detecting and then electrically regenerating it through a DWDM-type receiver. However, this approach presents various drawbacks. It is an expensive and time-consuming method since it operates in a serial manner - channel by channel - using serial channel scanning and BER or Q processing. Further, BER or Q is influenced by the receiver noise. Also, the tunable filter introduces signal distortions contributing to an increase in BER (decrease in Q) or a reduction in reliability.

[0010] Typically, in conventional applications, BER is determined by counting bits, a process which takes place in the time domain. Assuming a regular BER value in the order of 10^{-12} , and assuming a transmission bit rate of 2.5 Gb/s, it is to be expected that- on average- every 400 s of data flow one faulty bit is to be detected. To determine BER estimate with an acceptable accuracy, a testing time of several hours is necessary.

[0011] WO 01/052451 shows a system in which a measure of in-band cross-talk is made using DSP and a spectrum analyser to obtain an estimate of BER.

[0012] WO 00/71980 shows a method of calibrating a spectrometer using a reference signal to obtain calibratum data

[0013] It would be highly advantageous to have at one's disposal alternative, and simpler monitoring methods for faster fault detection and localization. Optical-domain methods, even if less accurate than electrical ones, can provide a fast, a simple, and an economical approach to reach this goal.

[0014] It would be of further advantage to have at hand a system that allows for real-time estimation of OSNR and BER or Q from the data representative of a real-world signal without the need for specific test signal sequences.

Object of the Invention

[0015] It is an object of this invention to provide a transducer and a method for processing signals in which the above-mentioned disadvantages are obviated or mitigated.

Summary of the Invention

[0016] In accordance with an aspect of the instant invention, there is provided a method for monitoring a quality of data transmission as defined by claim 1. Optional features are defined in the dependent claims.

[0017] In accordance with another aspect of the instant invention, there is provided an optical performance monitor as defined by claim 9.

[0018] Embodiments of the present invention will now be described by way of example only with reference to the accompanying drawings, in which:

Brief Description of the Drawings

[0019] Figure 1 is a schematic diagram of an embodiment of an OPM.

[0020] Figure 2 is a plot of the representation of two signals provided by an auxiliary transceiver included in the OPM of Figure 1.

[0021] Figure 3 is a schematic diagram of the auxiliary transducer included in the OPM of Figure 1.

- [0022] Figure 4 is a flow diagram illustrating the operation of the Flash of Figure 1.
 [0023] Figure 5 is a schematic diagram illustrating the methodology of quasi-dynamic measurand reconstruction.
 [0024] Figure 6 is a schematic diagram illustrating the methodology of quasi-dynamic system calibration.
 [0025] Figure 7 is a flow diagram illustrating the functionality of a neural network to be used for the determination of BER and/or Q.
 [0026] Figure 8 shows a schematic diagram of another embodiment of the FLASH of Figure 1.

Detailed Description of the Invention

[0027] The instant invention will now be described with reference to specific embodiments thereof. Of course, the invention is not restricted to a specific hardware device, but is to be utilized in connection with various hardware solutions. Various modifications to the disclosed embodiments will be readily apparent to those skilled in the art, and the general principles defined herein may be applied to other embodiments and applications without departing from the spirit and the scope of the invention. Thus, the instant invention is not intended to be limited to the embodiments disclosed, but is to be accorded the widest scope consistent with the principles and features disclosed herein.

[0028] Referring now to Figure 1, a schematic representation of an embodiment of a Flash OPM is shown. The Flash OPM 100 includes an optical user interface 10 that receives an optical input signal 12, and directs the received signal 12 to a spectrometric transducer 14. The spectrometric transducer 14 separates the input signal 12 into its spectral components and converts those components into corresponding electrical signals. The resultant data set $\{\tilde{y}_n\}$ 15 is representative of the spectrum of the optical signal 12. The spectrometric transducer 14 may utilise an optical element, such as a grating or a variable linear filter, to provide a spatial separation of the components of the signal 12 and direct them to a sensor array where they are converted into corresponding electrical signals. Such transducers are well known in the optical art and need not be described in further detail.

[0029] The data set $\{\tilde{y}_n\}$ 15 is directed to a processing function 16 that implements one or more of a first set of DSP algorithms (DSP Algorithms I) for signal reconstruction and enhancement. The processor 16 may be a general purpose computer implementing algorithms contained as software instructions resident in a memory device such as a data carrier. Alternatively, the processor may be a dedicated device configured to process the data set in accordance with the selected algorithm. The DSP Algorithms I, executed by the processor 16, will typically be chosen to perform reconstruction of spectrum parameters, using a non-linear and non-stationary approach, and provides estimates 17 for P, λ , and OSNR. Optionally, the processor 16 may also implement procedures that compensate for variations in temperature, wavelength drifts, aging of the optical components, and the like to enhance the information provided by the processor.

[0030] The output from the processor 16 provides estimates 17 of the power P, wavelength λ and signal to noise ratio OSNR which are sent to an electrical user interface 18. These outputs based on the spectral analysis quality of the data signal by using one or more of the parameters. For example the channel power may be used as an indicator of quality, or the central wavelength of the channel or by the OSNR.

[0031] BER or Q depends on all the elements of a telecommunication link. The spectrum of the transmitted signal contains more information on BER or Q than the estimates 17 of P, λ , OSNR that are possibly determined on the basis of the data $\{\tilde{y}_n\}$ 15 representative of said spectrum, but - as a rule - it does not contain sufficient information on chromatic dispersion and polarization-related effects such as PMD. In order to provide a meaningful estimate of BER or Q, it is necessary to complement spectral information with some time-domain parameters $\{p_{k,m}\}$ of the optical signal 12, sensitive to those phenomena. They may be next processed using a number of algorithmic solutions, based both on statistical means of inference and on various methods of multidimensional approximation, including artificial neural networks. To this end, the received signal 12 is also directed to an auxiliary transducer 20 in parallel to the spectrometric transducer 14. The auxiliary transducer 20 processes the received signal 12 to obtain a data set $\{\hat{p}_{k,m}\}$ 27 that represents time-domain parameters $\{p_{k,m}\}$ of the signal 12.

[0032] For example, the time domain parameters of a signal $s_k(t)$ transmitted by the k^{th} channel, may be defined as:

$$p_{k,m} = c \cdot \int_{t_{start}}^{t_{stop}} [s_k(t) - s_m^{th}] dt \quad \text{Equation 1}$$

where t is time, c is a normalization constant, and

$$s_m^{th} \in \left[\inf \{s_k(t) \mid t \in (-\infty, +\infty) \text{ and } k = 1, \dots, K\}, \sup \{s_k(t) \mid t \in (-\infty, +\infty) \text{ and } k = 1, \dots, K\} \right]$$

5

is the m^{th} threshold value $m = 1, \dots, M$; t_{start} and t_{stop} are appropriately chosen limits of integration interval. It will be appreciated that many alternative sets of parameters, that carry the same information about signal distortion, may be defined and the auxiliary transducer 20 constructed accordingly to produce the data set $\{\hat{\rho}_{k,m}\}$ 27.

10 **[0033]** Figures 2a and 2b show how the signal distortion is reflected in the parameters $\{\rho_{k,m}\}$ defined in the above described way. More specifically, in Figure 2a there are shown two demodulated signals 201 and 202, signal 201 being an undistorted square pulse signal while signal 202 is the same signal after distortion. Figure 2b shows the dependence

15 of the time-domain parameters $\{\hat{\rho}_{k,m}\}$ on the threshold value s_m^{th} for the undistorted and distorted signals 201 and 202, respectively. For instance, using Equation 1 with a threshold value of 0.2, the time-domain parameter $\{\hat{\rho}_{k,m}\}$ of distorted signal 202 may be viewed, as shown on Figure 2a, as the area 204 under curve (signal) 202 which is above line 203 (threshold). The distorted signal 202 results in time-domain parameters $\{\hat{\rho}_{k,m}\}$ that vary in a non-linear fashion as a consequence of the presence of distortion, which may be seen in Figure 2b by the difference between the time-domain

20 parameters for the undistorted signal 201 and the distorted signal 202 for a given threshold value s_m^{th} . For example, it

may be observed that for the threshold values 0.2, 0.4 and 0.7, the differences 211, 214 and 217 between the time-domain parameters 212, 215 and 218 of the undistorted signal 201 and the time-domain parameters 213, 216 and 219 of the distorted signal 202, respectively, are not equal. The non linearities may be used to provide an indication of the nature and degree of distortion to which the signal has been subjected. As such, signal 202 is processed so as to identify non-linearities relative to an ideal signal 201, and from these non-linearities provide an assessment of the degree or type of the distortion. Thus, the time-domain parameters $\{\hat{\rho}_{k,m}\}$ form a function that recognizes the shape of the distorted signal 202 and is indicative of the distortion, which may not be as readily apparent from the spectrum data set $\{\tilde{y}_n\}$.

25 **[0034]** In using the parameters defined above, the estimates $\{\hat{\rho}_{k,m}\}$ 27 may be obtained by an auxiliary transducer 20, shown in Figure 3, composed of a tunable filter 22 followed by a high-speed photodiode 24. The output of the diode 24 is processed by an integration circuit 26 to provide the output $\{\hat{\rho}_{k,m}\}$ 27. The tunable filter 22 is used to select a channel so that the associated photodiode 24 reproduces $s_k(t)$ by demodulation, and the integration circuit performs the operation such as that defined by Equation 1 for each of the selected thresholds.

30 **[0035]** The output 27 and 15 of the auxiliary transducer 20 and the spectrometric transducer 14, respectively, are provided to a processor 30 that implements selected ones of a second set of DSP algorithms (DSP Algorithms II) to extract further information from the received signal 12. The processor 30 may be a specific hardware implementation structured to perform a specific selected algorithm or may be a general-purpose computing device that operates upon the data sets 15 and 27 in accordance with programmed instructions contained on a memory device. The processor 30 executes one or more of the second set of selected DSP algorithms (DSP Algorithms II) to analyse the data $\{\tilde{y}_n\}$ 15 and $\{\hat{\rho}_{k,m}\}$ 27, and provide an estimate 35 for BER or Q. The estimate 35 is next transferred to the electrical user interface 18. The electrical user interface 18 transfers the estimates 17 and 35 of P, λ , OSNR, and BER or Q to the user that is assessing the performance of a particular channel, and to monitor the quality of a signal transmitted on said channel.

35 **[0036]** The interface 18 may function to provide readouts of the parameters being monitored but preferably operates to provide a visual indication of the departure of the parameters from predetermined acceptable levels. Thus the interface may monitor over a period of time the quality factor Q of the respective channels for a period of time and provide a signal indicating if the quality on one or more channels has varied from an acceptable value to an unacceptable value. Similarly, each channel may be monitored for BER and an indication provided if the BER has varied from an acceptable to an unacceptable value. By implementing the monitoring with the auxiliary transducer and processor, it is anticipated that the changes value may detected within one second.

40 **[0037]** The processing of the received signal 12 is depicted in the flow diagram of Figure 4. In a first step 41, the data $\{\tilde{y}_n \mid n = 1, \dots, N\}$ representative of the spectrum of a total DWDM signal are acquired, as well as the estimates $\{\hat{\rho}_{k,m} \mid k = 1, \dots, K; m = 1, \dots, M\}$ of some time-domain parameters $\{\rho_{k,m} \mid k = 1, \dots, K; m = 1, \dots, M\}$ of that signal, that are provided by the auxiliary transducer 20 and carry auxiliary information about signal distortion. The first set of DSP algorithms (DSP Algorithms I), which will be described further below, is used to determine the estimates 17 of the parameters P, λ , and OSNR for each channel - on the basis of the data $\{\tilde{y}_n\}$ 15, step 42. In step 43, those data $\{\tilde{y}_n\}$ 15 are used again, this time together with the estimates $\{\hat{\rho}_{k,m}\}$ 27 of the time-domain parameters, to determine the estimate 35 of BER or Q. In this step, the second set of algorithms (DSP Algorithms II), which will be described further below, is used. In a last

50

55

step 44, there are reported the estimates 17 and 35 of P , λ , OSNR and BER or Q, useful for a network monitoring system.

[0038] The method, as illustrated in Figure 4, provides a number of advantages compared to traditional out-of-service BER-test techniques. The method is an optical-layer testing method, which is also an in-service method. A BER test of all channels is performed in parallel and thus simultaneously. The method provides a low-cost solution as well as a fast solution to the problem of in-service monitoring of DWDM networks. Test times, according to the method described in Figure 4, remain substantially constant as channel counts increase. Also, the described method does not depend on the transmission protocol, on the data format or on the generation of complex test signals.

[0039] The first subset of algorithms (DSP Algorithms I), used for determination of the estimates 17 of the parameters P , λ , and OSNR, contains the algorithms for spectrum reconstruction and estimation of spectrum parameters that are well known in the art, for example those described in detail in US Pat. No. 5,991,023 to Morawski et al., issued November 23, 1999, and in US Pat. No. 6,002,479 to Barwicz et al., issued December 14, 1999. These may be, in particular, the algorithms of spectrum reconstruction based on the parameterization of the spectrum of the form:

$$x(\lambda) = \sum_{k=1}^K [a_{1,k} v(\lambda - l_k) + a_{2,k} v_{\Pi}(\lambda - l_k)]$$

where:

$\mathbf{a}_1 = [a_{1,1} \dots a_{1,K}]^T$, $\mathbf{a}_2 = [a_{2,1} \dots a_{2,K}]^T$, $\mathbf{l} = [l_1 \dots l_K]^T$ are the vectors of parameters to be estimated;
 $\mathbf{l} = [l_1 \dots l_K]^T$ is the vector of ITU-recommended channel wavelength values;
 $v(\lambda)$ is a function modelling the normalized spectrum of a monitored telecommunication channel;
 $v_{\Pi}(\lambda)$ is a function modelling a normalized pedestal, accompanying the spectrum monitored telecommunication channel, in the simplest case:

$$v_{\Pi}(\lambda) = \frac{1}{\Delta\lambda_{\Pi}} \left[1 \left(\lambda - \frac{\Delta\lambda_{\Pi}}{2} \right) - 1 \left(\lambda + \frac{\Delta\lambda_{\Pi}}{2} \right) \right].$$

[0040] In this case, the estimates 17 of the channel parameters P , λ , OSNR may be calculated directly from the estimates of \mathbf{a}_1 , \mathbf{a}_2 , and \mathbf{l} .

[0041] The second set of DSP algorithms (DSP Algorithms II), used for extracting useful BER and Q information, may be constructed according to the following principles. A spectrometric transducer 14 converts input optical signal into a set of data $\{\tilde{y}_n\}$ representative of the spectrum of this signal. The spectrometric transducer 14 is, for example, part of a Type-II FLASH device, but it is not restricted to such devices and applications. An output-related discretisation of a wavelength axis is defined by a sequence $\{\lambda_n\}$ such that $\lambda_{\min} = \lambda_1 < \lambda_2 < \dots < \lambda_{N-1} < \lambda_N = \lambda_{\max}$, where N is a number of data. For example, in a Type-II Flash OPM having a detector array, such as the one described in Figure 1, N represents a number of photodiodes in the detector array. Thus, the average interval between wavelengths, in the given example equivalent to the distance two neighbouring photodiodes are adjusted to each other, is given by $\Delta\lambda = (\lambda_{\max} - \lambda_{\min}) / (N - 1)$. It is assumed that the data $\{\tilde{y}_n\}$ represent a spectrum of K channels combined in a DWDM system under consideration. A subsequence of data $\{\tilde{y}_n \mid n = N_{k,\min}, \dots, N_{k,\max}\}$ is used, together with the information indicative of the signal distortion within the time-domain parameters $\{\hat{\rho}_{k,m}\}$ provided by the auxiliary transducer 20, for estimation of BER or Q. Further, the length of this subsequence is variable, and amounts for example to 3, 4, 5, 6 or more elements. In the following, for the sake of simplicity, considerations are limited to one channel only, and the symbol $\{\tilde{y}_n\}$ is used for denoting this subsequence. A person of skill in the art is able to extend the concept with ease to any other number of channels.

[0042] The problem of determining BER or Q may be solved in a broad context of algorithmic options, which are derived from ideas of quasi-dynamic measurand reconstruction that is a well-established and well-recognised methodology in digital signal processing, as for example illustrated in the paper "The Role of Digital Signal Processing in Measurement Science", published in "Measurement Science - A Discussion" (Ohmsha Press Pub., Tokyo 2000, pp. 77-102). High redundancy of measurement information in raw measurement data is the main distinctive feature of any problem of quasi-dynamic measurand reconstruction. Consequently, implicit or explicit compression of data is present in any procedure for solving such a problem. The value of a scalar measurand x , BER or Q, is estimated on the basis of a subsequence of data $\{\tilde{y}_n\}$ representative of the channel spectrum and the parameters $\{\hat{\rho}_{k,m}\}$ to which the measurand is approximately related..

[0043] A large family of DSP methods for estimation of BER or Q may be derived from the general methodology for solving problems of quasi-dynamic measurand reconstruction. This methodology consists of two steps: compression of the data $\{\tilde{y}_n\}$ 15 and $\{\hat{\rho}_{k,m}\}$ 27, i.e. transformation of the data $\{\tilde{y}_n\}$ 15 and $\{\hat{\rho}_{k,m}\}$ 27 into an estimate $\hat{\mathbf{p}}$ 32 of a vector of informative parameters \mathbf{p} , $\{\tilde{y}_n\}, \{\hat{\rho}_{k,m}\} \rightarrow \hat{\mathbf{p}}$, and subsequent estimation of x on the basis of $\hat{\mathbf{p}}$, $\hat{\mathbf{p}} \rightarrow \hat{x}$. This methodology is illustrated in the schematic diagram shown in Figure 5. Inputs containing the subsequence $\{\tilde{y}_n\}$ 15 and $\{\hat{\rho}_{k,m}\}$ 27 are provided to a data compressor 31. The data compressor 31 compresses the subsequence $\{\tilde{y}_n\}$ 15 and $\{\hat{\rho}_{k,m}\}$ 27 to obtain a set containing an estimate \mathbf{p} 32, which is provided to a BER or Q estimator 33. When properly calibrated, the BER or Q estimator 33 responds with an output set 35 containing an estimate \hat{x} of x , i.e. of BER or Q. A complexity of the method illustrated in Figure 5 depends on a number of informative parameters, i.e. the dimension of the vector \mathbf{p} 32. The greater the number of informative parameters, the more time is required both for calibration and for BER or Q estimation.

[0044] The calibration of the Flash OPM 100 is an important step in the methodology described above. It is to be performed on the basis of reference data, which are structured as

$\mathcal{D}^{\text{cal}} = \left\{ \left\{ \tilde{x}_v^{\text{cal}}, \left\{ \tilde{y}_{n,v}^{\text{cal}} \right\} \& \left\{ \hat{\rho}_{m,v}^{\text{cal}} \right\} \right\} \mid v = 1, \dots, N^{\text{cal}} \right\}$. In Figure 6, a schematic diagram for a method of calibration is

outlined. An input containing the subsequence $\left\{ \tilde{y}_{n,v}^{\text{cal}} \right\}$ 61 and $\left\{ \hat{\rho}_{m,v}^{\text{cal}} \right\}$ 62 is provided to a data compressor 63. The

data compressor 63 compresses the subsequence $\left\{ \tilde{y}_{n,v}^{\text{cal}} \right\}$ 61, and computes an estimate of a vector of informative

parameters $\hat{\mathbf{p}}_v^{\text{cal}}$ 64, corresponding to reference values $\tilde{x}_{n,v}^{\text{cal}}$, on the basis of $\left\{ \tilde{y}_{n,v}^{\text{cal}} \right\}$ and $\left\{ \hat{\rho}_{m,v}^{\text{cal}} \right\}$ for $v = 1, \dots,$

N^{cal} . The set 64 containing the parameters $\hat{\mathbf{p}}_v^{\text{cal}}$ is provided to a BER or Q estimator 65. The BER or Q estimator 65

responds with an output set 66 containing a datum $\hat{x}_{n,v}^{\text{cal}}$ 66. In a data adjustor 67, the data $\hat{x}_{n,v}^{\text{cal}}$ 66 and $\tilde{x}_{n,v}^{\text{cal}}$ are

compared. The result of this comparison is provided as feedback to the data compressor 62 and the BER or Q estimator 65, where in turn this information is utilized in constructing an approximation of the relationship $\mathbf{p} \rightarrow x$ using a set of

input- output pairs: $\left\{ \left\{ \hat{\mathbf{p}}_v^{\text{cal}}, \tilde{x}_v^{\text{cal}} \right\} \mid v = 1, \dots, N^{\text{cal}} \right\}$.

[0045] A large variety of algorithms is possibly generated by combining various techniques of data compression with various types of approximators. For example, the following techniques of data compression are optionally used: principal component analysis, computation of inner products of the data $\{\tilde{y}_n\}$ 15 and $\{\hat{\rho}_{k,m}\}$ 27 and linearly independent sequences $\{e_{j,n} \mid j = 1, \dots, J\}$, approximation of the spectrum $y(\lambda)$ on the basis of $\{\tilde{y}_n\}$ 15 and $\{\hat{\rho}_{k,m}\}$ 27 using a parameterised function $y(\lambda; \mathbf{a})$ with \mathbf{a} being a vector of parameters, and computation of the moments of the spectrum $y(\lambda)$ on the basis of $\{\tilde{y}_n\}$ 15. In the considered case, an application-specific vector of informative parameters could contain estimates 17 of P , λ , and OSNR, the estimates determined on the basis of $\{\tilde{y}_n\}$ 15 and $\{\hat{\rho}_{k,m}\}$ 27. The most evident candidate for the measurand estimator, i.e. the BER or Q estimator, is a neural network being a universal approximator. Alternatively, B-splines are to be considered as measurand estimators. A person of skill in art will be able to suggest further methods of data compression and final measurand estimation.

[0046] For example, following a straightforward approach, a Radial Basis Functions (RBF) neural network 34 is designed as illustrated in the schematic diagram shown in Figure 7. This particular network performs both the function of data compressor and of BER/Q estimator. The neural network 34 receives as inputs data sets $\{\tilde{y}_n\}$ 15 and $\{\hat{\rho}_{k,m}\}$ 27. The neural network 34 is trained to respond with an estimate \hat{x} 35 of x (BER or Q) on the basis of $\{\tilde{y}_n\}$ and $\{\hat{\rho}_{k,m}\}$. It is important for training the network that the data set $\{\tilde{y}_n\}$ 15 stem from a low-resolution spectrometric transducer and the parameters $\{\hat{\rho}_{k,m}\}$ 27 from an auxiliary transducer. The sets of data used for training preferably represent a telecommunication signal distorted in various ways by its propagation through optical elements such as fibers, amplifiers, and filters. Instead of a RBF neural network, any other universal approximator may be used, e.g. another type of neural network or a multi-dimensional spline function. Instead of one neural network a cascade of two neural networks may be designed: the first to perform the function of data compressor, the second - of BER/Q estimator.

[0047] Referring now to Figure 8, a schematic representation of another embodiment of the Flash OPM 100a is shown, in which the Flash OPM 100a is adapted so as to provide data suitable for use in a special application related to performance monitoring, viz. controlling a Digital Gain Equalizer (DGE). Like components will be described with like reference numerals with a suffix "a" added for clarity. The Flash OPM 100a includes an optical user interface 10a, that

provides received signal 12a to a spectrometric transducer 14a. A processor 16a implements a first set of DSP algorithms (DSP Algorithms I). The output of the processor 16a is applied to the electrical user interface 18a and to a further processor 50 that implements a further set of DSP algorithms (DSP Algorithms III). The received signal 12a is also fed to an auxiliary transducer 20a and to the processor 30a for implementing the second set of DSP algorithms (DSP Algorithms II) as described above to obtain estimate 35a of BER or Q. The processor 50 utilises the DSP algorithms (DSP Algorithms II) to process the estimates 17a of P, λ , and OSNR according to information suitable for control of DGE. A person of skill in the art easily envisions further applications of DSP-type processing units. These applications are feasible, since the spectrum retrieved by the spectrometric transducer, such as 14, 14a, and processed by the processors 16, 16a, inherently contain relevant and significant information characterizing the input optical signal.

[0048] The data processing performed by optical performance monitors, such as 100 and 100a takes place within a time range of 50-200 milliseconds. This allows for *in situ* monitoring of an optical signal transmitted on a given channel, and for immediate undertaking of measures to reroute an optical signal to an alternative channel, once a too high value of BER or too low value of Q is detected. Assuming a response time of the monitor of 50 milliseconds, and a transmission bit rate of 2.5 Gb/s, a data buffer of 1.6 MB is sufficient to ensure that no data are lost during the detection of a fault-signalling BER or Q value and rerouting of an optical signal. By shifting the determination of BER or Q values from the electrical domain into the optical domain, a continuous, real-time quality assessment of an optical channel is possible, and it is further possible to route data transmission without a significant loss of information.

Claims

1. A method for monitoring a quality of data transmission of at least one optical channel 12, the method comprising the steps of :

directing an optical signal to a spectrometric transducer 14 to determine a data set $\{\tilde{y}_n\}$ representative of a spectrum of said optical signal 12, said optical signal 12 transmitted on said at least one optical channel 12 at an instance in time;

also directing said optical signal 12 to an auxiliary transducer 20 in parallel to said spectrometric transducer 14 to obtain another data set $\{Pkm\}$ from said optical signal 12 indicative of time domain parameters of said optical signal 12;

performing an analysis on both of said data sets $\{\tilde{y}_n\}$ $\{Pkm\}$ to determine an estimate of a predetermined parameter "x" of said optical signal.

2. A method for monitoring a quality of data transmission according to claim 1, wherein said predetermined parameter of said the data transmission is selected from the group comprising a bit-error rate of the data transmission, wavelength, optical signal to noise ratio (OSNR) and a quality factor Q of the data transmission.

3. A method for monitoring a quality of data transmission according to any one of claims 1 to 2, wherein the step of spectrum analysis to determine a quality of the optical signal comprises the steps of : performing a spectral decomposition of the optical signal; determining a set of data representative of a result of said spectral decomposition; and obtaining an estimate "x" of a predetermined parameter "x", "x" being either one of bite error rate and quality factor, from the set of data the predetermined parameter "x" describing a quality of the optical signal.

4. A method for monitoring a quality of data transmission according to claim 3; wherein the estimate "x" is determined by a comparison of the set of data with an ideal set of data.

5. A method for monitoring a quality of data transmission according to claim 4, wherein the comparison is performed using a processor for computing the estimate from an identified correlation of the predetermined parameter "x" and the set of data.

6. A method for monitoring a quality of data transmission according to claim 5, wherein the processor for computing the estimate "x" from an identified correlation of the predetermined parameter "x" and the set of data is a neural network.

7. A method for monitoring a quality of data transmission according to any one of claims 1 to 6, wherein the quality of more than one optical channel is monitored by a same process of spectrum analysis.

8. A method for monitoring a quality of data transmission according to any one of claims 1 to 7, wherein said prede-

terminated parameter of at least one optical channel is monitored over a period of time, and wherein an indication signal is provided, the indication signal indicative of at least one optical channel on which the value of said parameter has varied from an acceptable value to an unacceptable value.

- 5 9. An optical performance monitor (100) for monitoring an optical signal (12) and providing an estimate of a predetermined parameter "x" of that signal (12), the optical performance monitor (100) comprising:
- 10 a spectrometric transducer (14) for performing a spectral decomposition of the incident optical signal (12), and for transforming the decomposed optical signal into a first data set $\{\tilde{y}_n\}$ representative of the spectrum of said optical signal (12);
- an auxiliary transducer (20) to also receive said optical signal (12) in parallel to said spectrometric transducer (14) and provide as an output a second data set $\{Pkm\}$ representative of time-domain parameters of said signal (12); and,
- 15 a processor to receive each of said data sets and to apply thereto digital signal processing routines (16, 30) to obtain estimates of said predetermined parameter.

Patentansprüche

- 20 1. Verfahren zum Überwachen einer Qualität einer Datenübertragung von mindestens einem optischen Kanal 12, wobei das Verfahren die Schritte enthält:
- Richten eines optischen Signals auf einen spektrometrischen Transducer 14 zum Bestimmen eines Datensatzes $\{\tilde{y}_n\}$, der repräsentativ ist für ein Spektrum des optischen Signals 12, wobei das optische Signal 12 auf dem
- 25 mindestens einen optischen Kanal 12 bei einem Zeitpunkt übertragen wird;
- ebenso Richten des optischen Signals 12 auf einen Hilfstransducer 20 parallel zu dem spektrometrischen Transducer 14 zum Erlangen eines anderen Datensatzes $\{Pkm\}$ von dem optischen Signal 12, das kennzeichnend ist für Zeitbereichsparameter des optischen Signals 12;
- Durchführen einer Analyse beider Datensätze $\{\tilde{y}_n\}$ $\{Pkm\}$ zum Bestimmen eines Schätzwerts eines vorbestimmten Parameters "x" des optischen Signals.
- 30
2. Verfahren zum Überwachen einer Qualität einer Datenübertragung nach Anspruch 1, bei dem der vorbestimmte Parameter der Datenübertragung ausgewählt wird aus der Gruppe, die enthält: eine Bit- Fehler- Rate der Datenübertragung, eine Wellenlänge, eine optisches Signal- Zu- Rausch- Rate (OSNR) und einen Qualitätsfaktor Q der Datenübertragung.
- 35
3. Verfahren zum Überwachen einer Qualität einer Datenübertragung nach einem der Ansprüche 1 bis 2, bei dem der Schritt der Spektrumsanalyse zum Bestimmen einer Qualität des optischen Signals den Schritt enthält: Durchführen einer Spektralzerlegung des optischen Signals; Bestimmen eines Satzes von Daten, die repräsentativ sind für ein Ergebnis der Spektralzerlegung; und Erlangen eines Schätzwerts "x" eines vorbestimmten Parameters "x", wobei "x" entweder die Bit-Fehler-Rate oder der Qualitätsfaktor ist, von dem Datensatz, wobei der vorbestimmte Parameter "x" eine Qualität des optischen Signals beschreibt.
- 40
4. Verfahren zum Überwachen einer Qualität der Datenübertragung nach Anspruch 3, bei dem der Schätzwert "x" bestimmt wird durch einen Vergleich des Satzes von Daten mit einem idealen Satz von Daten.
- 45
5. Verfahren zum Überwachen einer Qualität einer Datenübertragung nach Anspruch 4, bei dem der Vergleich durchgeführt wird unter Verwendung eines Prozessors zum Berechnen des Schätzwerts aus einer identifizierten Korrelation des vorbestimmten Parameters "x" und dem Satz von Daten.
- 50
6. Verfahren zum Überwachen einer Qualität einer Datenübertragung nach Anspruch 5, bei dem der Prozessor zum Berechnen des Schätzwerts "x" von einer identifizierten Korrelation des vorbestimmten Parameters "x" und dem Satz von Daten ein neuronales Netzwerk ist.
- 55
7. Verfahren zum Überwachen einer Qualität einer Datenübertragung nach einem der Ansprüche 1 bis 6, bei dem mit einem gleichen Spektrumsanalyseprozess die Qualität von mehr als einem optischen Kanal überwacht wird.
8. Verfahren zum Überwachen einer Qualität einer Datenübertragung nach einem der Ansprüche 1 bis 7, bei dem der

vorbestimmte Parameter von mindestens einem optischen Kanal über eine Zeitperiode überwacht wird, und bei dem ein Anzeigesignal bereitgestellt wird, wobei das Anzeigesignal kennzeichnend ist für mindestens einen optischen Kanal, auf dem der Wert des Parameters sich von einem akzeptablen Wert zu einem nicht akzeptablen Wert geändert hat.

5

9. Optisches Leistungsüberwachungsgerät (100) zum Überwachen eines optischen Signals (12) und zum Bereitstellen eines Schätzwerts eines vorbestimmten Parameters "x" dieses Signals (12), wobei das optische Leistungsüberwachungsgerät (100) enthält:

10 einen spektrometrischen Transducer (14) zum Durchführen einer Spektralzerlegung eines eintreffenden optischen Signals (12) und zum Transformieren des zerlegten optischen Signals in einen ersten Datensatz $\{\tilde{y}_n\}$, der repräsentativ ist für das Spektrum des optischen Signals (12),
 einen Hilfstransducer (20), der ebenso das optische Signal (12) parallel zu dem spektrometrischen Transducer (14) empfängt und als ein Ausgangssignal einen zweiten Datensatz $\{Pkm\}$ bereitstellt, der repräsentativ ist für
 15 Zeitbereichsparameter des Signals (12); und
 einen Prozessor zum Empfangen der Datensätze und zum Anwenden von Digitalsignalverarbeitungsroutinen (16, 30) auf diese, um Schätzwerte des vorbestimmten Parameters zu erhalten.

20 **Revendications**

1. Procédé pour contrôler une qualité de transmission de données d'au moins un canal optique 12, le procédé comprenant les étapes qui consistent :

25 à diriger un signal optique vers un transducteur spectrométrique 14 pour déterminer un ensemble de données $\{\tilde{y}_n\}$ représentatif d'un spectre du signal optique 12, ledit signal optique 12 étant transmis sur ledit canal optique 12 au niveau d'une instance dans le temps ;
 à diriger également le signal optique 12 vers un transducteur auxiliaire 20 parallèlement au transducteur spectrométrique 14 pour obtenir à partir du signal optique 12 un autre ensemble de données $\{Pkm\}$ indiquant des
 30 paramètres de domaine de temps du signal optique 12 ;
 à effectuer une analyse sur les deux ensembles de données $\{\tilde{y}_n\}$ $\{Pkm\}$ pour déterminer une estimation d'un paramètre "x" prédéterminé du signal optique.

35 2. Procédé pour contrôler une qualité de transmission de données selon la revendication 1, étant précisé que ledit paramètre de la transmission de données est sélectionné dans le groupe constitué par le taux d'erreurs binaires de la transmission de données, une longueur d'onde, un rapport signal optique-bruit (OSNR) et un facteur de qualité Q de la transmission de données.

40 3. Procédé pour contrôler une qualité de transmission de données selon l'une quelconque des revendications 1 à 2, étant précisé que l'étape de l'analyse de spectre pour déterminer une qualité du signal optique comprend les étapes qui consistent : à effectuer une décomposition spectrale du signal optique ; à déterminer un ensemble de données représentatif d'un résultat de la décomposition spectrale ; et à obtenir une estimation "x" d'un paramètre "x" prédéterminé, "x" étant un taux d'erreurs binaires ou un facteur de qualité, à partir de l'ensemble de données, le paramètre "x" prédéterminé décrivant une qualité du signal optique.

45 4. Procédé pour contrôler une qualité de transmission de données selon la revendication 3, étant précisé que l'estimation "x" est déterminée grâce à une comparaison de l'ensemble de données avec un ensemble de données idéal.

50 5. Procédé pour contrôler une qualité de transmission de données selon la revendication 4, étant précisé que la comparaison est réalisée à l'aide d'un processeur pour calculer l'estimation à partir d'une corrélation identifiée du paramètre "x" prédéterminé et de l'ensemble de données.

55 6. Procédé pour contrôler une qualité de transmission de données selon la revendication 5, étant précisé que le processeur pour calculer l'estimation "x" à partir d'une corrélation identifiée du paramètre "x" prédéterminé et l'ensemble de données est un réseau neuronal.

7. Procédé pour contrôler une qualité de transmission de données selon l'une quelconque des revendications 1 à 6, étant précisé que la qualité de plus d'un canal optique est contrôlée par un même traitement d'analyse de spectre.

EP 1 685 663 B1

8. Procédé pour contrôler une qualité de transmission de données selon l'une quelconque des revendications 1 à 7, étant précisé que le paramètre prédéterminé d'au moins un canal optique est contrôlé sur une période de temps, et qu'un signal d'indication est fourni, le signal d'indication indiquant au moins un canal optique sur lequel la valeur du paramètre a varié à partir d'une valeur acceptable jusqu'à une valeur inacceptable.

5

9. Dispositif de contrôle des performances optiques (100) pour contrôler un signal optique (12) et pour fournir une estimation d'un paramètre "x" prédéterminé de ce signal (12), le dispositif de contrôle des performances optiques (100) comprenant :

10 un transducteur spectrométrique (14) pour effectuer une décomposition spectrale du signal optique incident (12) et pour transformer le signal optique décomposé en un premier ensemble de données $\{\tilde{y}_n\}$ représentatif du spectre du signal optique (12) ;

15 un transducteur auxiliaire (20) pour recevoir également le signal optique (12) parallèlement au transducteur spectrométrique (14) et pour fournir comme sortie un second ensemble de données $\{P_{km}\}$ représentatif de paramètres de domaine de temps du signal optique (12) ;

un processeur pour recevoir chacun des ensembles de données et pour leur appliquer des routines de traitement de signaux numériques (16, 30) pour obtenir des estimations du paramètre prédéterminé.

20

25

30

35

40

45

50

55

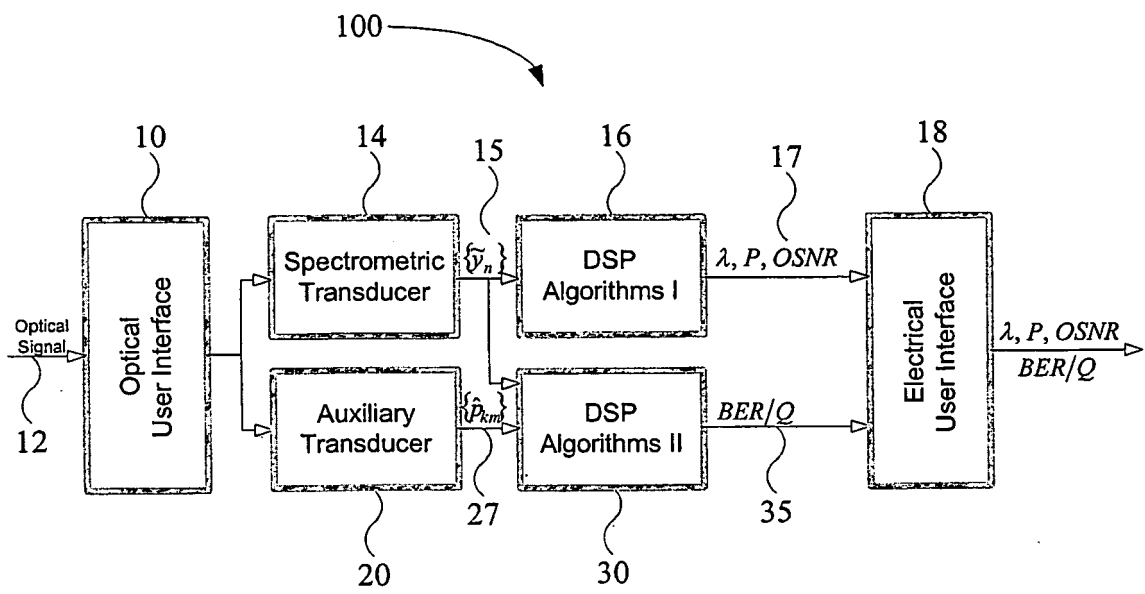

Figure 1

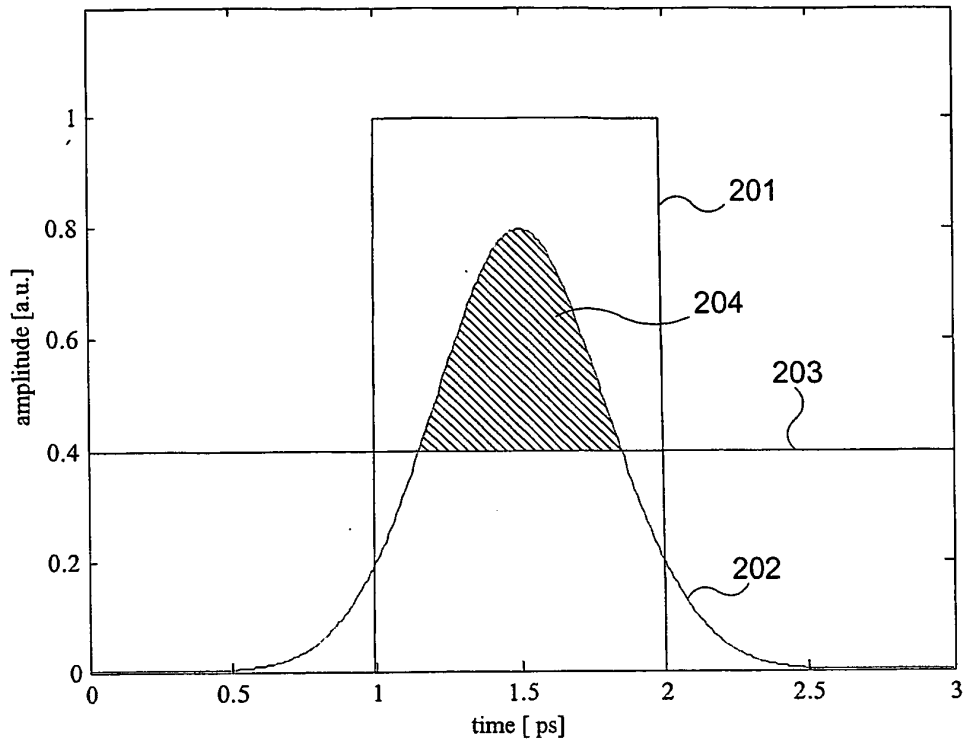

Figure 2a

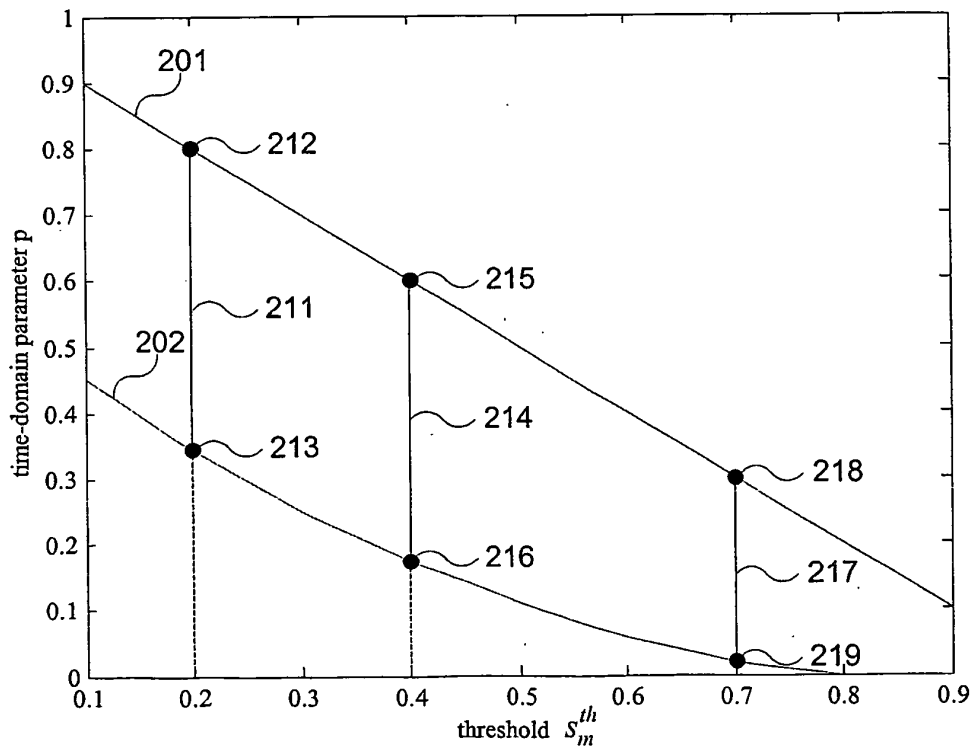

Figure 2b

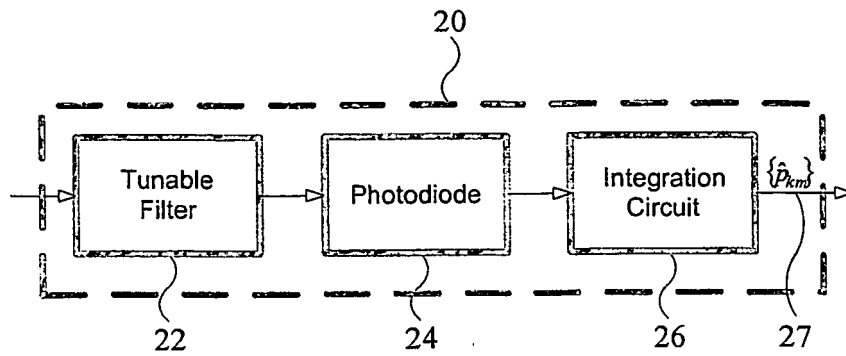

Figure 3

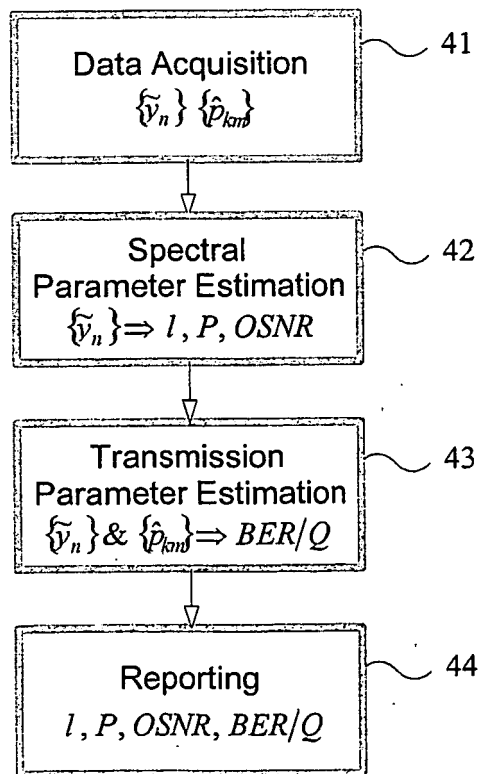

Figure 4

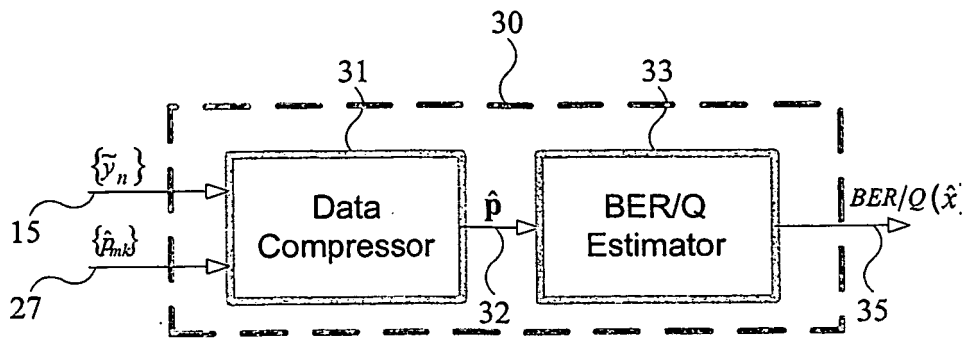

Figure 5

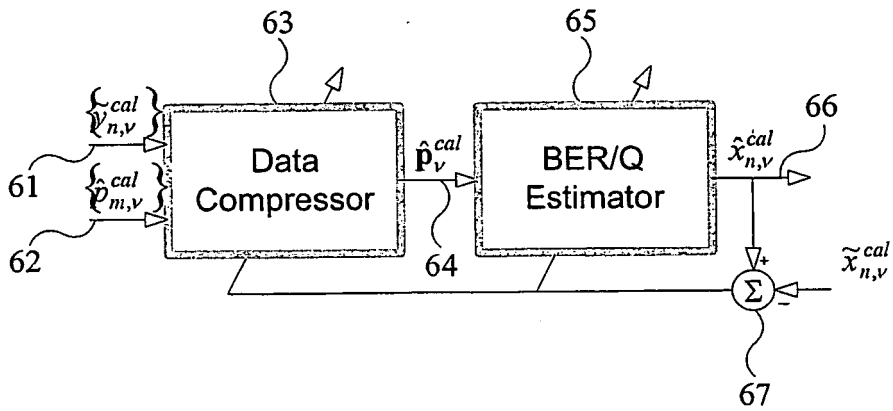

Figure 6

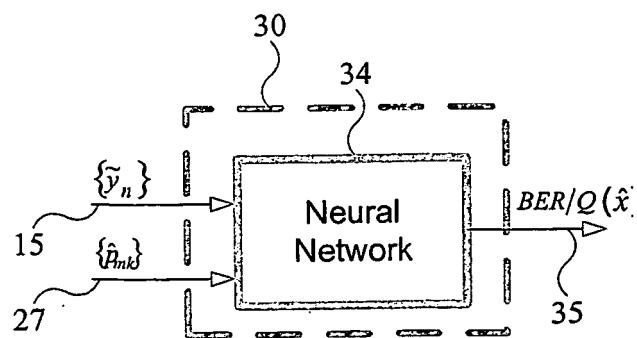

Figure 7

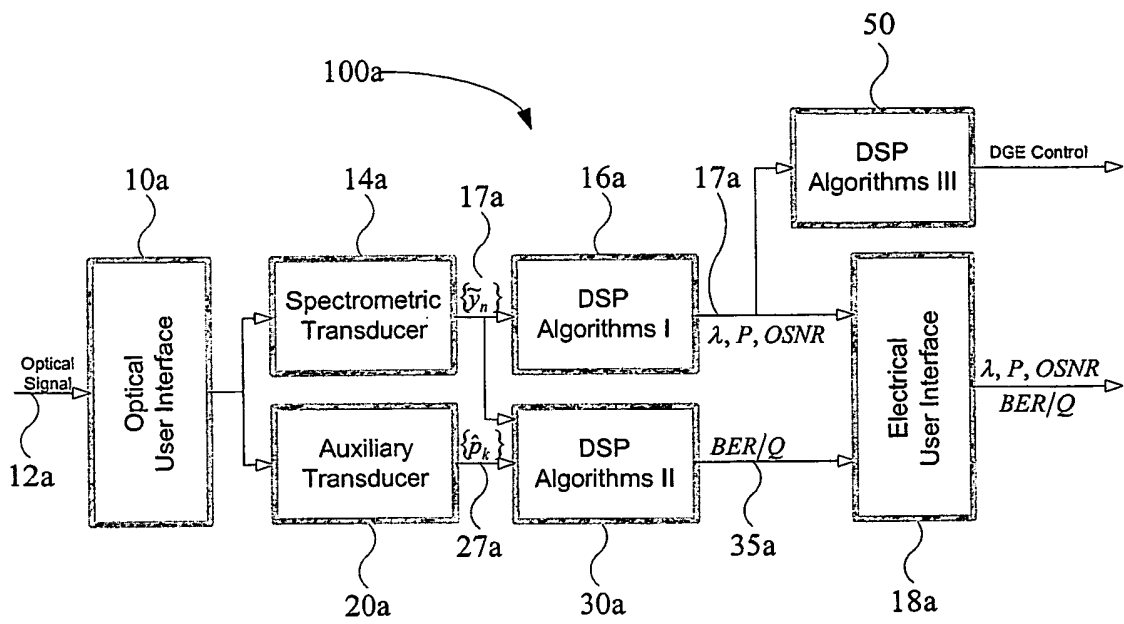

Figure 8

REFERENCES CITED IN THE DESCRIPTION

This list of references cited by the applicant is for the reader's convenience only. It does not form part of the European patent document. Even though great care has been taken in compiling the references, errors or omissions cannot be excluded and the EPO disclaims all liability in this regard.

Patent documents cited in the description

- WO 01052451 A [0011]
- WO 0071980 A [0012]
- US 5991023 A, Morawski [0039]
- US 6002479 A, Barwicz [0039]

Non-patent literature cited in the description

- The Role of Digital Signal Processing in Measurement Science. Measurement Science - A Discussion. Ohmsha Press Pub, 2000, 77-102 [0042]