

C. E. DAILEY.  
MACHINE FOR WINDING CORD.  
APPLICATION FILED AUG. 18, 1904.

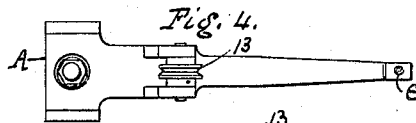
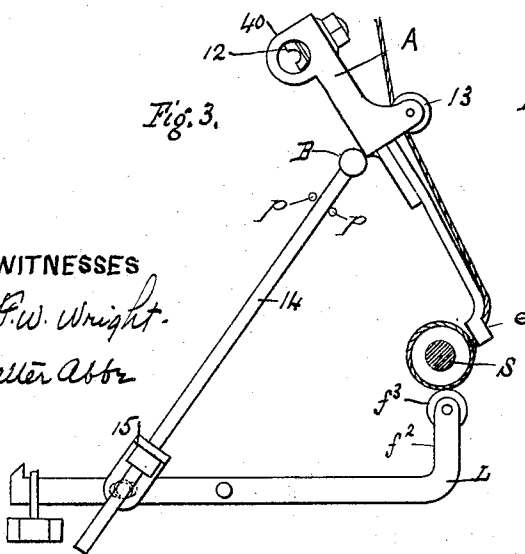
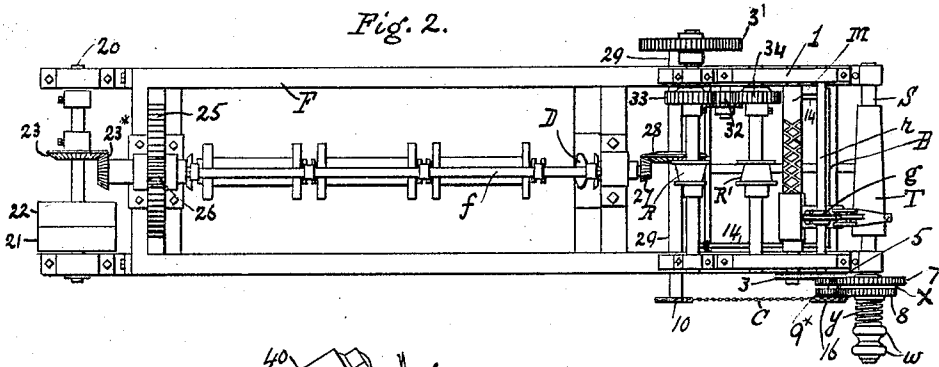
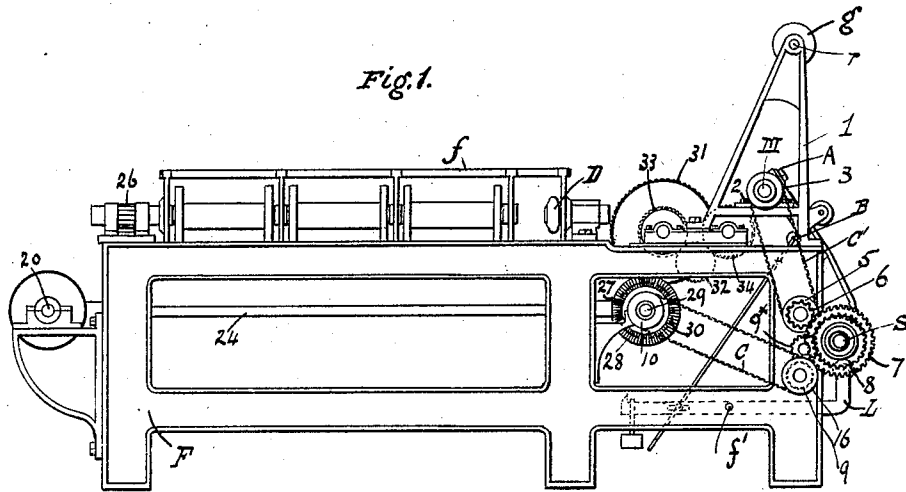

WITNESSES  
*F. W. Wright.*  
*Miller Abbott*

INVENTOR  
*Carolus E. Dailey*

BY  
*Hawson Hawson*

ATTORNEYS

# UNITED STATES PATENT OFFICE.

CAROLUS E. DAILEY, OF NEW YORK, N. Y.

## MACHINE FOR WINDING CORD.

SPECIFICATION forming part of Letters Patent No. 783,247, dated February 21, 1905.

Application filed August 18, 1904. Serial No. 221,302.

*To all whom it may concern:*

Be it known that I, CAROLUS E. DAILEY, a citizen of the United States of America, residing in the borough of Brooklyn, New York city, county of Kings, State of New York, have invented an Improved Machine for Winding Cord, of which the following is a specification.

The object of this invention is to provide means for winding cord, particularly the heavy sizes, in reversed spirals or universally-wound rolls, which may be advantageously of cylindrical shape, dispensing with bobbins, reels, or like retaining means commonly used for heavy cord, so that the roll of cord produced can be packed, shipped, and handled without danger of coming apart.

In the accompanying drawings, Figure 1 is a side elevation of a twisting-machine supplied with my invention. Fig. 2 is a plan of Fig. 1. Fig. 3 is a side elevation of my improved cord-carrying guide-arm and mechanism for its control, all other parts of the machine being omitted for sake of clearness. Fig. 4 is a plan of Fig. 3, and Fig. 5 is a rear elevation of the cord guide-arm.

The twisting-machine proper consists of a frame F, on the upper part of which is mounted the flier-frame *f*, carrying a number of spools of the strands to be twisted into cord. The strands are fed from the flier-frame through tube D, from which they pass in twisted condition over a pair of capstans R R'. Motion is imparted to the machine from a driving-shaft 20, provided with fast and loose pulleys 21 22 and a bevel-pinion 23, meshing with a bevel-gear 23\* at one end of a longitudinal shaft 24. A pinion 25 on said shaft 24 meshes with a gear 26 on the shaft of the flier to give it its rotary motion, while a bevel-pinion 27 at the end of the shaft 24 meshes with a bevel-pinion 28 on a counter-shaft 29. The capstans R R' are actuated by a pinion 30 (shown in dotted lines, Fig. 1) on the shaft 29, meshing with a spur-gear 31 on the shaft of the capstan R, while a pinion 32 on a stud on the frame meshes with a spur-gear 33 on shaft of the capstan R and also with a spur-gear 34 on the shaft of the capstan R'. From the capstan R' the twisted strands are passed over suitable pulleys and through an eye of

a guide-arm, as hereinafter described, and wound onto a shaft S. The shaft S is rotated by means of a friction-disk X, located between adjacent side faces of the spur-gears 7 and 8, the gear 7 being fast on the shaft S, while the gear 8 is loosely mounted on said shaft and pressed against the friction-disk by a spring *y*. A pinion 9 and sprocket 16 together freely turn on a stud in the frame F. The pinion 9 gears into a pinion 9\* in mesh with the pinion 8, and the sprocket 16 receives its motion from a sprocket 10 on the counter-shaft 29 by means of a chain C. Hand-operated adjusting-nuts *w* are placed on the shaft to enable one to change the tension of the spring *y*.

According to this invention I mount an upright frame 1 at the delivery end of the frame F and mount a grooved wheel *g* on a transverse rod *r*, extending across the frame. The wheel is free to turn on the rod and is also freely movable longitudinally along the rod. In the lower part of the frame 1, in suitable bearings 2, I mount a right and left threaded feed-screw M, rotated by a sprocket-wheel 3 through a chain C', running over a sprocket 5, turning as a part of a pinion 6, which meshes with the gear 7. The shaft S is provided with a tapered portion T, upon which the cord is to be wound. On the right-and-left-feed-screw shaft M, I mount an arm A, Figs. 3, 4, and 5, having two collar portions fitting and sliding on said rod, with an intermediate pivoted stud 11, having a curved part 12 at its lower end, adapted to engage the feed-screw threads. A freely-pivoted wheel 13 is provided in suitable bearings on the arm A, and the arm at its outer end carries a guide-eye *e*. This guide-arm A rests upon a bar B, parallel with the shaft M and extending across the machine, being supported by a pair of inclined rods 14, which are guided between pins *p*. (See Fig. 3.) The rods 14 are secured at their lower ends by a cross-rod 15 and form a rectangular frame, with the bar B at its upper side. The lower end of this rectangular frame is pivoted to a weighted lever L, which is itself pivoted in the frame F at *f'*. The lever L carries at its upturned end *f''* a freely-pivoted

roller  $f^3$ , adjacent to and adapted to bear upon the roll being wound on the shaft S.

In operation the twisted cord is brought from the capstans, taken up over the freely-mounted wheel  $g$  on the shaft  $r$ , down under the wheel 13 of the guide-arm A, through the guide-eye  $e$ , and onto the shaft S, where it is wound in reversed spirals because of the to-and-fro movement given the arm A by the right and left thread engaging the stud of the arm A. In order that such reversed spiral winding may be properly accomplished, it is necessary that the eye  $e$  be always maintained a certain predetermined distance away from the gradually-increasing roll. This is accomplished by the device hereinbefore described and best shown in Fig. 3. As the roll increases in diameter the roller  $f^3$  of the lever L will be forced down, swinging the lever on its pivot, raising the bar B, and with it the guide-arm A, thus raising it at the eye the same distance that the roll has increased in diameter.

The flyer-frame shown is revolved at a substantially constant speed; but I find it essential that the speed with which the winding-shaft S is revolved be made variable and elastic with relation thereto. Therefore I provide the friction driving-disk before described. The guide-arm, however, as shown, should be given its to-and-fro motion at a speed relative to the revolutions of the shaft S.

I claim as my invention—

1. Apparatus for winding cord, comprising a winding-shaft, a cord-guide, means for moving said guide back and forth relatively to said shaft and mechanism for automatically holding the cord-guide a predetermined distance from the surface of the cord-roll as it is formed.

2. Apparatus for winding cord, comprising a winding-shaft, a cord-guide, and shaft there-

for, and means for moving said guide to and fro on said shaft, said guide having an extending arm with an eye adapted to rest near, but not upon the roll being formed, a frame and automatic means for moving the frame to maintain the cord-guide always a predetermined distance from the roll as it is formed.

3. Apparatus for winding cord, comprising a winding-shaft, a right and left threaded feed-shaft, a guide-arm mounted on said feed-shaft and adapted to be traversed to and fro thereon, a system of levers adapted to support the arm and a roller for said system of levers adapted to bear on the roll of cord being formed.

4. An apparatus for winding cord, comprising a winding-shaft on which a roll is adapted to be wound, a frame therefor, a roller bearing on said roll, a lever carrying said roller, a transverse rod connected to said lever, a guide-arm and a shaft therefor on which it is movable to and fro, said arm resting on said transverse rod.

5. An apparatus for winding cord, comprising a winding-shaft on which a roll is adapted to be wound, a frame, a lever pivoted in said frame carrying a roller on one end adjacent to said roll, and a rectangular frame on the other end, a transverse right and left threaded feed-shaft in the frame, a guide-arm having a stud engaging said threaded feed-shaft, said arm resting on said rectangular frame and having its end adjacent to the roll being formed and means to operate said roll and shaft.

In testimony whereof I have signed my name to this specification in the presence of two subscribing witnesses.

CAROLUS E. DAILEY.

Witnesses:

F. WARREN WRIGHT,  
WALTER ABBE.