



(11) **EP 3 706 513 B1**

(12) **EUROPEAN PATENT SPECIFICATION**

(45) Date of publication and mention of the grant of the patent:
01.03.2023 Bulletin 2023/09

(51) International Patent Classification (IPC):
H05B 45/345^(2020.01) H05B 45/385^(2020.01)

(21) Application number: **20161373.4**

(52) Cooperative Patent Classification (CPC):
H05B 45/345; H05B 45/385

(22) Date of filing: **06.03.2020**

(54) **LED DRIVER CIRCUIT AND LED LIGHTING DEVICE THEREOF**

LED-TREIBERSCHALTUNG UND LED-BELEUCHTUNGSVORRICHTUNG DAFÜR

CIRCUIT DE COMMANDE DE DEL ET DISPOSITIF D'ÉCLAIRAGE À DEL ASSOCIÉ

(84) Designated Contracting States:
AL AT BE BG CH CY CZ DE DK EE ES FI FR GB GR HR HU IE IS IT LI LT LU LV MC MK MT NL NO PL PT RO RS SE SI SK SM TR

(30) Priority: **06.03.2019 CN 201920284763 U**

(43) Date of publication of application:
09.09.2020 Bulletin 2020/37

(73) Proprietor: **Xiamen Eco Lighting Co., Ltd. Xiamen Fujian 363999 (CN)**

(72) Inventors:
• **WEN, Shuisheng**
Xiamen, Fujian 361010 (CN)
• **LIN, Liping**
Xiamen, Fujian 361010 (CN)

(74) Representative: **Cristinelli, Luca et al**
Jacobacci & Partners S.p.A.
Corso Emilia, 8
10152 Torino (IT)

(56) References cited:
CN-A- 108 882 450 US-A1- 2014 239 810
US-B1- 8 058 815

EP 3 706 513 B1

Note: Within nine months of the publication of the mention of the grant of the European patent in the European Patent Bulletin, any person may give notice to the European Patent Office of opposition to that patent, in accordance with the Implementing Regulations. Notice of opposition shall not be deemed to have been filed until the opposition fee has been paid. (Art. 99(1) European Patent Convention).

Description

Field of the Invention

[0001] The present invention relates to electronic circuitry, and more particularly, to a LED driver circuit according to claim 1 and a LED lighting device according to claim 8 utilizing the LED driver circuit. Preferred embodiments of the invention are defined by the dependent claims.

Background

[0002] A conventional light apparatus, more specifically, a LED apparatus, is more likely driven via a constant current output. And its output current is constant. Also, its output voltage matches the LED light apparatus's input voltage requirements. Its output power decreases in proportional to the LED apparatus's input voltage. When its driving output voltage is lower, its driving power is correspondingly lower. And it significantly limits the LED apparatus's driving function. In other words, the conventional LED apparatus's driving function is significantly limited because of a lower driving power that comes from a smaller driver output voltage.

[0003] US2014239810 discloses a power factor correction (PFC) converter with current regulated output implemented in an LED lighting system in the industrial/home lighting field. However, the problems mentioned above remain unsolved.

Summary of the Invention

[0004] The present invention aims at disclosing a LED driver circuit and a driver device that relieve the conventional LED apparatus of its significantly limited driving functions caused by when it confronts a lower driving output voltage and in turn a lower driving power.

[0005] First, the present invention discloses a LED driver circuit that includes a first voltage drop module, a constant current driving module, an auxiliary winding module, a second voltage drop module, a DIP switch module, and a control module. The first voltage drop module is connected to a power source. Also, the first voltage drop module converts the direct current voltage. The constant current driving module is connected to the first voltage drop module. In addition, the constant current driving module receives the converted direct current voltage for driving a loading module. The auxiliary winding module is connected to the first voltage drop module and the constant current driving module. Moreover, the auxiliary winding module receives the converted direct current voltage to output an actual voltage level for driving. The second voltage drop module is connected to the first voltage drop module. Besides, the second voltage drop module bucks the converted direct current voltage to output an optimized voltage. The DIP switch module is connected to the second voltage drop module. And the DIP switch

module receives the optimized voltage, selects a predetermined current level, and outputs an electrical signal. The control module is connected to the DIP switch module, the second voltage drop module, the auxiliary winding module and the constant current driving module. The control module outputs a pulse signal to control that corresponds to the electrical signal for controlling the constant current driving module. The constant current driving module calculates the required voltage level and determines the working status of the loading module based on a voltage level relationship between the required voltage level and the actual voltage level.

[0006] Second, the present invention discloses a driver device that includes the loading module and the disclosed LED driver circuit. The disclosed LED driver circuit and the disclosed driver device include: a first voltage drop module, a constant current driving module, a second voltage drop module, a DIP switch module, an auxiliary winding module, a control module and a loading module. A direct current voltage is converted for driving a loading module. In addition, the converted direct current voltage is bucked to generate an optimized voltage that powers the DIP switch module and the control module. Moreover, the DIP switch module selects a level of a predetermined current and correspondingly outputs an electrical signal to the control module. In this fashion, the control module outputs a corresponding pulse signal for regulating a current passing through the loading module. Also, the control module calculates a required voltage level for driving. And the control module compares the required voltage level with the actual voltage level output by the auxiliary winding module for determining the working status of the loading module.

[0007] In this way, the disclosed driver circuit and the disclosed driver device regulate various levels of currents to drive various types of LED apparatuses. Also, they determine the output loading voltage to keep the output power constant. On top of that, the disclosed driver circuit and the disclosed driver device relieve the conventional LED apparatus of its significantly limited driving function introduced by a smaller driving output voltage and in turn a smaller driving power.

[0008] These and other objectives of the present invention will no doubt become obvious to those of ordinary skill in the art after reading the following detailed description of the preferred embodiment that is illustrated in the various figures and drawings.

Brief Description of the Drawings

[0009]

Figure 1 illustrates a LED driver circuit's module structure according to one embodiment of the present invention.

Figure 2 illustrates how a first voltage drop module, an auxiliary winding module and a constant current driving module of a LED driver circuit are connected

to a loading module according to one example.

Figure 3 exemplarily illustrates a second voltage drop module of a LED driver circuit is connected to a control module according to one example.

Figure 4 exemplarily illustrates a DIP switch module of a LED driver circuit according to one example.

Detailed Description

[0010] The disclosed LED driver circuit and the disclosed driver device include a first voltage drop module, a constant current driver module, a second voltage drop module, a DIP switch module, an auxiliary winding module, a control module and a loading module. A direct current voltage is converted to drive a loading module. The converted direct current voltage is bucked to generate an optimized voltage that powers the DIP switch module and the control module. The DIP switch module selects a level of a predetermined current and in turn outputs an electrical signal to the control module. Such that the control module outputs a corresponding pulse signal for regulating a current passing through the loading module. Meanwhile, the control module calculates a required voltage level for driving. Also, the control module compares the required voltage level with an actual voltage level output by the auxiliary winding module and in turn determines the working status of the loading module. In this fashion, the disclosed driver circuit and the disclosed driver device regulate various levels of currents to drive various types of LED apparatuses. In addition, they determine the output loading voltage to keep the output power constant.

[0011] Figure 1 demonstrates a LED driver circuit's module structure according to one embodiment of the present invention. For clear explanation, only the parts related to the disclosed embodiment are shown. Detailed explanations are as follows:

[0012] The disclosed LED driver circuit includes a first voltage drop module 102, a constant current driving module 103, an auxiliary winding module 108, a second voltage drop module 105, a DIP switch module 106 and a control module 107.

[0013] The first voltage drop module 102 is connected to a power source 101 for converting a direct current voltage.

[0014] The constant driving module 103 is connected to the first voltage drop module 102 for receiving the converted direct current voltage that is then used for driving the loading module 104.

[0015] The auxiliary winding module 108 is connected to the first voltage drop module 102 and the constant driving module 103. And the auxiliary winding module 108 receives the converted direct current voltage and in turn outputs an actual voltage level for driving.

[0016] The second voltage drop module 105 is connected to the first voltage drop module 102. In addition, the second voltage drop module 105 bucks the converted direct current voltage and then outputs an optimized volt-

age.

[0017] The DIP switch module 106 is connected to the second voltage drop module 105. Moreover, the DIP switch module 106 receives the optimized voltage, selects a predetermined current level, and in turn outputs an electrical signal.

[0018] The control module 107 is connected to the DIP switch module 106, the second voltage drop module 105, the auxiliary winding module 108 and the constant current driving module 103. Besides, the control module 107 outputs a pulse signal that corresponds to the electrical signal for controlling the constant current driving module 103. In addition, the control module 107 calculates the required voltage level for driving and determines the working status of the loading module 104 based on a voltage level relationship between the required voltage level and the actual voltage level.

[0019] In one embodiment, determining the loading module 104's working status according to the voltage level relationship between the required voltage level and the actual voltage level includes: (1) When the actual voltage level is lower than the required voltage level, the actual output power conforms to the required driving output power. Therefore, the control module 107 determines that the loading module 104 is under a normal working status. (2) When the actual voltage level is higher than the required voltage level, the actual output power is higher than the required driving output power. In this fashion, the control module 107 determines that the loading module 104 pauses its work.

[0020] In one embodiment, the power source 101 may be a direct current power source or an alternating current power source that is rectified to generate another direct current voltage to the first voltage drop module 102.

[0021] In one embodiment, the LED driver circuit includes a transformer T1. And the transformer T1 has a primary winding that is connected to the constant current driver module 103, and has a secondary winding that is connected to the loading module 104.

[0022] In one embodiment, the DIP switch module 106 selects a predetermined current level and then outputs an electrical signal to the control module 107. Also, the control module 107 converts the electrical signal from analog to digital. Such that the control module 107 identifies a current level set by the DIP switch module 106. Moreover, the control module 107 then calculates an actual output current and outputs a PWM signal that has a corresponding duty ratio. In this way, the control module 107 regulates a current that passes through the loading module 104. Meanwhile, the control module 107 calculates a required power that corresponds to the constant output power according to the predetermined current level set by the DIP switch module 106.

[0023] Figure 2 exemplarily demonstrates how the first voltage drop module 102, the auxiliary winding module 108, the constant driving module 103 are connected to the loading module 104 in the disclosed LED driver circuit according to one embodiment.

[0024] For clearer explanations, only partial descriptions that are related to the embodiment are described. The explanations are as follows:

In one embodiment, the first voltage drop module 102 includes a voltage drop chip U2, a second capacitor C2, and a fifth diode D5.

[0025] The voltage drop chip U2 has an input end that is connected to the power source 101.

[0026] The output end VSEN of the voltage drop chip U2 has an output end VSEN that is connected to the auxiliary winding module 108. Also, the second capacitor C2 has a first end that is connected to the auxiliary winding module 108.

[0027] The voltage drop chip U2 has a ground end GND that is connected to ground. In addition, the fifth diode device D5 has a negative end that is connected to ground.

[0028] The second capacitor C2 has a second end that is connected to the fifth diode device D5's positive end.

[0029] In one embodiment, the constant current driving module 103 includes a driver chip U1, a transistor Q1, a first diode D1 and a first resistor R1.

[0030] First, the driver chip U1 has an input end Vin that is connected to the first voltage drop module 102.

[0031] Second, the driver chip U1 has a control end PWM that is connected to the control module 107.

[0032] Third, the driver chip U1 has a driver end IRV that is connected to the first diode D1's negative end.

[0033] Fourth, the second diode D1's positive end is connected to the first transistor Q1's control end.

[0034] Fifth, the driver chip U1's output end ISEN, the first transistor Q1's input end, and the first resistor R1's first end are connected to each other.

[0035] Sixth, the driver chip U1's ground GND and the first resistor R1's second end are connected to ground.

[0036] The first transistor Q1's output end is connected to the loading module 104. Specifically, the first transistor Q1 may be a transistor or a field effect transistor. A collector end, an emitting end and a base end of the transistor are respectively the input end, the output end and the control end of the first transistor Q1. A drain end, a source end and a gate end of the field effect transistor are respectively the input end, the output end and the control end of the first transistor Q1.

[0037] In one embodiment, the auxiliary winding module 108 includes a third diode D3, a fourth diode D4, a third capacitor C3, a fourth capacitor C4, a fourth resistor R4, a Zener diode DZ1, a second transistor Q2 and an inductor P.

[0038] The third diode device D3's negative end, and the third capacitor C3's first end are connected to the first voltage drop module 102. The third diode device D3's positive end is connected to the second transistor Q2's output end. The second transistor Q2's control end, the Zener diode DZ1's negative end and the fourth resistor R4's first end are connected to each other. The second transistor Q2's input end, the fourth diode D4's negative end, the fourth resistor R4's second end, and the fourth

capacitor C4's first end are connected to each other. The third capacitor C3's second end, the Zener diode DZ1's positive end, and the fourth capacitor C4's second end are connected to each other. The fourth diode D4's positive end is connected to ground via the inductor P. Specifically, the second transistor Q2 may be a transistor or a field effect transistor. The collecting end, the emitting end and the base end of the transistor are respectively an input end, an output end and a control end of the second transistor Q2. The drain end, the source end and the gate end of the field effect transistor are respectively the input end, the output end and the control end of the second transistor Q2.

[0039] Figure 3 demonstrates how the second voltage drop module 105 is connected to the control module 107 in the disclosed LED driver circuit according to one embodiment. For clearer explanations, only partial descriptions related to the embodiment is described. The detailed explanations are as follows:

In one embodiment, the second voltage drop module 105 includes a voltage drop chip U3. The voltage drop chip U3's input end Vin is connected to the first voltage drop module 102. The voltage drop chip U3's output end Vout is connected to the DIP switch module 106. The voltage drop chip U3's ground end GND is connected to ground.

[0040] In one embodiment, the control module 107 includes a main control chip U4. The main control chip U4's input end VCC is connected to the second voltage drop module 105. The main control chip U4's first receiver end PA2 and second receiver end PA3 are connected to the DIP switch module 106. The main control chip U4's control end PA1 is connected to the constant driving module 103. The main control chip U4's input end ADC is connected to the auxiliary winding module 108. The main control chip U4's ground end GND is connected to ground.

[0041] Figure 4 exemplarily demonstrates the DIP switch module 106 in detail in the disclosed LED driver circuit according to one embodiment. For clearer explanations, only partial descriptions that are related to the embodiment are shown. The detailed explanations are as follows:

In one embodiment, the DIP switch module 106 includes a fifth resistor R5, a sixth resistor R6, a first DIP switch SW1 and a second DIP switch SW2. The fifth resistor R5's first end and the sixth resistor R6's first end are connected to the second voltage drop module 105. The fifth resistor R5's second end and the first DIP switch SW1's first end are connected to the control module 107. The sixth resistor R6's second end and the second DIP switch SW2's first end are connected to the control module 107. The first DIP switch SW1's second end and the second DIP switch SW2's second end are connected to ground.

[0042] The present invention also discloses a driver device that includes a loading module 104 and the above-disclosed LED driver circuit. Specifically, as shown in Figure 2, the loading module 104 includes a second diode

D2, a first capacitor C1, a second resistor R2, and a light emit diode LED. The second diode D2's positive end is connected to the constant current driving module 103. The second diode D2's negative end, the first capacitor C1's first end, and the second resistor R2's first end are connected to the light emit diode LED's first end. The first capacitor C1's second end and the second resistor R2's second end are connected to the light emit diode LED's second end.

[0043] According to descriptions related to Figures 1-4, how the disclosed LED driver circuit and the disclosed driver device work is depicted as follows.

[0044] After the first voltage drop module 102 bucks the direct current voltage, the constant current driving module 103 forwards the bucked direct current voltage to drive the loading module 104.

[0045] Meanwhile, after the second voltage drop module 105 bucks the bucked direct current voltage again, the second voltage drop module 105 provides a stable operating voltage to the control module 107 and the DIP switch module 106 via the double-bucked direct current voltage.

[0046] The DIP switch module 106 selects a required output current level and sets a corresponding amount of DIPs that correspond to the required output current level. For example: one DIP switch controls two levels of currents, and N DIP switches control 2^N (i.e., 2 to the power of N) levels of currents, where N is a positive integer.

[0047] The DIP switch module 106 includes a DIP switch and a pull-up resistor. A common end of the DIP switch and the pull-up resistor is used for outputting signals. When the DIP switch is turned on, the common end outputs a low electrical level. Also, when the DIP switch is turned off, the common end outputs a high electrical level. The DIP switch module 106's PWN (IN) end is connected to the control module 107's PWN (IN) end. Through high and low electrical levels input by the PWM(IN) end, a desired current level is determined.

[0048] The control module 107 calculates using both a maximal output current and the current level signal input by the DIP switch module 106 to generate a PWM signal. Via the control module 107's PWM (OUT) end, the PWM signal is transmitted to the constant current driving module 103 for outputting a corresponding current level. Meanwhile, based on the control module 107 calculates a maximal output voltage level V_{max} that corresponds to a constant output power according to the current level selected by the DIP switch module 106.

[0049] After connecting to the loading module 104, the auxiliary winding module 108 is connected to the control module 107's ADC end.

[0050] The control module 107 converts the input voltage at its ADC end from analog to digital. Also, the control module 107 calculates the driving output voltage level V_{out} and compares the driving output voltage level V_{out} with the maximal output voltage V_{max} .

[0051] If the actual loading voltage level V_{out} fails to exceed the maximal output voltage V_{max} , it indicates

that the actual output power conforms to the required output power. Such that the loading module 104 operates normally. If the actual loading voltage level V_{out} exceeds the maximal output voltage V_{max} , it indicates that the actual output power is higher than the required output power. Such that the loading module 104 pauses its operation.

[0052] Therefore, the DIP switch module 106 regulates the output current. In addition, the regulated output current automatically matches the corresponding output voltage. Such that the driving constant output power stays constant.

[0053] In this way, the disclosed LED driver circuit has various types of luminance loading constant output power that cover lighting apparatuses of multiple types of serial connections and in turn relieve clients' burdens in dealing with more driving models.

[0054] To sum up, the disclosed LED driver circuit and the disclosed driver device that includes a first voltage drop module, a constant current driving module, a second voltage drop module, a DIP switch module, an auxiliary winding module, a control module and a loading module.

[0055] A direct current voltage is converted to drive the loading module. The converted direct current voltage is then bucked to generate an optimized voltage for powering the DIP switch module and the control module. The DIP switch module selects the predetermined current level and correspondingly outputs the electrical signal to the control module. Such that the control module outputs the corresponding pulse signal to regulate the current that passes through the loading module.

[0056] Meanwhile, the control module calculates the required voltage level for driving. Also, the control module compares the required voltage level with the actual voltage level output by the auxiliary winding module to determine the working status of the loading module. Therefore, various current levels can be regulated to drive different types of LED lighting apparatuses, and it leads to a broader range of applications.

[0057] The disclosed driver circuit and the disclosed driver device additionally determine the output loading voltage for keeping the output power stable. In this fashion, the disclosed driver circuit and the disclosed driver device relieves the conventional LED driving circuit of its driving limit that comes from a smaller driving output power and an accompanying lower driving power.

[0058] Those skilled in the art will readily observe that numerous modifications and alterations of the device and method may be made while retaining the teachings of the invention.

[0059] Accordingly, the above disclosure should be construed as limited only by the scope of the appended claims.

Claims

1. A LED driver circuit, comprising:

a first voltage drop module (102) for connecting to a power source (101), and configured to convert a direct current voltage;

a constant current driving module (103), connected to the first voltage drop module (102), and configured to receive the converted direct current voltage to drive a loading module (104);
 an auxiliary winding module (108), connected to the first voltage drop module (102) and the constant current driving module (103), and configured to receive the converted direct current voltage and to correspondingly output an actual voltage level;

characterized in that the LED driver circuit further comprises:

a second voltage drop module (105), connected to the first voltage drop module (102), and configured to buck the converted direct current voltage and to correspondingly output a bucked voltage;

a DIP switch module (106), connected to the second voltage drop module (105), and configured to receive the bucked voltage for powering the DIP switch module, to select a predetermined current level, and to output an electrical signal; and

a control module (107), connected to the DIP switch module (106), the second voltage drop module (105), the auxiliary winding module (108) and the constant current driving module (103), wherein said control module (107) is arranged to receive said electrical signal, the bucked voltage for powering the control module, and to identify the current level set by the DIP switch module and output a corresponding pulse signal that corresponds to the electrical signal, said pulse signal for controlling the constant current driving module (103), and said control module (107) is configured to calculate a required voltage level and to determine a working status of the loading module (104) based on a voltage level relationship between the required voltage level and the actual voltage level;

wherein said control module (107) is configured to determine that the working status of the loading module (104) is under a normal working status, when the actual voltage level is lower than the required voltage level, and to determine that the working status of the loading module (104) is a pause working status, when the actual voltage level is higher than the required voltage level.

2. The LED driver circuit of claim 1, wherein the first voltage drop module (102) comprises:

a voltage drop chip, having an input end for con-

necting to the power source (101), having an output end connected to the auxiliary winding module (108), and having a ground end connected to ground;

a second capacitor, having a first end connected to the auxiliary winding module (108); and
 a fifth diode device, having a negative end connected to ground, and having a positive end connected to a second end of the second capacitor.

3. The LED driver circuit of any one of claims 1 to 2, wherein the constant current driving module (103) comprises:

a driver chip, having an input end connected to the first voltage drop module (102), having a control end connected to the control module (107), and a ground end connected to ground;
 a first transistor, having an input end connected to an output end of the driver chip, and having an output end connected to the loading module (104);

a first diode, having a negative end connected to a driver end of the driver chip, and having a positive end connected to a control end of the first transistor; and

a first resistor, having a first end connected to the output end of the driver chip, and having a second end connected to ground.

4. The LED driver circuit of any one of claims 1 to 3, wherein the second voltage drop module (105) comprises a voltage drop chip, having an input end connected to the first voltage drop module (102), having an output end connected to the DIP switch module (106), and having a ground end connected to ground.

5. The LED driver circuit of any one of claims 1 to 4, wherein the auxiliary winding module (108) comprises:

a third diode, having a negative end connected to the first voltage drop module (102);

a fourth diode;

a third capacitor, having a first end connected to the first voltage drop module (102);

a fourth capacitor, having a first end connected to a positive end of the fourth diode, and having a second end connected to the second end of the third capacitor;

a fourth resistor, having a second end connected to the first end of the fourth capacitor;

a Zener diode, having a negative end connected to a second end of the third capacitor;

a second transistor, having an output end connected to a positive end of the third diode, having a control end connected to a positive end of the Zener diode and a first terminal of the fourth re-

sistor, and having an input end connected to the first end of the fourth capacitor; and an inductor, connected to a negative end of the fourth diode and ground.

6. The LED driver circuit of any one of claims 1 to 5, wherein the DIP switch module (106) comprises:

a fifth resistor, having a second end connected to the control module (107);

a sixth resistor, having a first end connected to a first end of the fifth resistor and to the second voltage drop module (105), and having a second end connected to the control module (107);

a first DIP switch, having a first end connected to the second end of the fifth resistor, and having a second end connected to ground; and

a second DIP switch, having a first end connected to the second end of the sixth resistor, and having a second end connected to ground.

7. The LED driver circuit of any one of claims 1 to 6, wherein the control module (107) comprises a main control chip that has an input end connected to the second voltage drop module (105), has a first receiver end and a second receiver end connected to the DIP switch module (106), has a control end connected to the constant current driving module (103), has an input end connected to the auxiliary winding module (108), and has a ground end connected to ground.

8. A driver device, **characterized by** comprising a loading module (104) and the LED driver circuit of any one of claims 1 to 7.

9. The driver device of claim 8, wherein the loading module (104) further comprises:

a second diode, having a positive end connected to the constant current driving module (103);

a first capacitor, having a first end connected to a negative end of the second diode;

a second resistor, having a first end connected to the negative end of the second diode; and

a light emit diode, having a first end connected to the negative end of the second diode, and having a second end connected to both a second end of the first capacitor and a second end of the second resistor.

Patentansprüche

1. LED-Treiberschaltung, die Folgendes umfasst:

ein erstes Spannungsabfallmodul (102) zum Verbinden mit einer Stromquelle (101) und kon-

figuriert zum Umwandeln einer Gleichspannung;

ein Konstantstrom-Treibermodul (103), das mit dem ersten Spannungsabfallmodul (102) verbunden ist und dazu konfiguriert ist, die umgewandelte Gleichspannung zu empfangen, um ein Lademodul (104) anzusteuern;

ein Hilfswicklungsmodul (108), das mit dem ersten Spannungsabfallmodul (102) und dem Konstantstrom-Treibermodul (103) verbunden ist und dazu konfiguriert ist, die umgewandelte Gleichspannung zu empfangen und entsprechend einen Ist-Spannungspegel auszugeben; **dadurch gekennzeichnet, dass** die LED-Treiberschaltung ferner Folgendes umfasst:

ein zweites Spannungsabfallmodul (105), das mit dem ersten Spannungsabfallmodul (102) verbunden ist und dazu konfiguriert ist, die umgewandelte Gleichspannung abzusinken und entsprechend eine abgesenkte Spannung auszugeben;

ein DIP-Schaltermodul (106), das mit dem zweiten Spannungsabfallmodul (105) verbunden ist und dazu konfiguriert ist, die abgesenkte Spannung zum Versorgen des DIP-Schaltermoduls mit Strom zu empfangen, einen vorbestimmten Strompegel auszuwählen und ein elektrisches Signal auszugeben; und

ein Steuermodul (107), das mit dem DIP-Schaltermodul (106), dem zweiten Spannungsabfallmodul (105), dem Hilfswicklungsmodul (108) und dem Konstantstrom-Treibermodul (103) verbunden ist, wobei das Steuermodul (107) angeordnet ist, um das elektrische Signal zu empfangen, wobei die abgesenkte Spannung zum Versorgen des Steuermoduls mit Strom dient, und die von dem DIP-Schaltermodul eingestellte Stromstärke zu erkennen und ein entsprechendes Impulssignal auszugeben, das dem elektrischen Signal entspricht, wobei das Impulssignal zum Steuern des Konstantstrom-Treibermoduls (103) dient, und das Steuermodul (107) dazu konfiguriert ist, einen Soll-Spannungspegel zu berechnen und einen Arbeitsstatus des Lademoduls (104) basierend auf einer Spannungspegelbeziehung zwischen dem Soll-Spannungspegel und dem Ist-Spannungspegel zu bestimmen;

wobei das Steuermodul (107) dazu konfiguriert ist, zu bestimmen, dass der Arbeitsstatus des Lademoduls (104) unter einem normalen Arbeitsstatus ist, wenn der Ist-Spannungspegel niedriger als der Soll-Spannungspegel ist, und zu bestimmen,

- dass der Arbeitsstatus des Lademoduls (104) ein Pausen-Arbeitsstatus ist, wenn der Ist-Spannungspegel höher als der Soll-Spannungspegel ist.
2. LED-Treiberschaltung nach Anspruch 1, wobei das erste Spannungsabfallmodul (102) Folgendes umfasst:
- einen Spannungsabfallchip mit einem Eingangsende zum Verbinden mit der Stromquelle (101), mit einem Ausgangsende, das mit dem Hilfswicklungsmodul (108) verbunden ist, und mit einem Masseende, das mit Masse verbunden ist;
- einen zweiten Kondensator mit einem ersten Ende, das mit dem Hilfswicklungsmodul (108) verbunden ist; und
- eine fünfte Diodenvorrichtung mit einem negativen Ende, das mit Masse verbunden ist, und einem positiven Ende, das mit einem zweiten Ende des zweiten Kondensators verbunden ist.
3. LED-Treiberschaltung nach einem der Ansprüche 1 bis 2, wobei das Konstantstrom-Treibermodul (103) Folgendes umfasst:
- einen Treiberchip mit einem Eingangsende, das mit dem ersten Spannungsabfallmodul (102) verbunden ist, mit einem Steuerende, das mit dem Steuermodul (107) verbunden ist, und mit einem Masseende, das mit Masse verbunden ist;
- einen ersten Transistor mit einem Eingangsende, das mit einem Ausgangsende des Treiberchips verbunden ist, und mit einem Ausgangsende, das mit dem Lademodul (104) verbunden ist;
- eine erste Diode mit einem negativen Ende, das mit einem Treiberende des Treiberchips verbunden ist, und mit einem positiven Ende, das mit einem Steuerende des ersten Transistors verbunden ist; und
- einen ersten Widerstand mit einem ersten Ende, das mit dem Ausgangsende des Treiberchips verbunden ist, und mit einem zweiten Ende, das mit Masse verbunden ist.
4. LED-Treiberschaltung nach einem der Ansprüche 1 bis 3, wobei das zweite Spannungsabfallmodul (105) Folgendes umfasst: einen Spannungsabfallchip mit einem Eingangsende, das mit dem ersten Spannungsabfallmodul (102) verbunden ist, einem Ausgangsende, das mit dem DIP-Schaltermodul (106) verbunden ist, und einem Masseende, das mit Masse verbunden ist.
5. LED-Treiberschaltung nach einem der Ansprüche 1
- bis 4, wobei das Hilfswicklungsmodul (108) Folgendes umfasst:
- eine dritte Diode mit einem negativen Ende, das mit dem ersten Spannungsabfallmodul (102) verbunden ist;
- eine vierte Diode;
- einen dritten Kondensator mit einem ersten Ende, das mit dem ersten Spannungsabfallmodul (102) verbunden ist;
- einen vierten Kondensator mit einem ersten Ende, das mit einem positiven Ende der vierten Diode verbunden ist, und mit einem zweiten Ende, das mit dem zweiten Ende des dritten Kondensators verbunden ist;
- einen vierten Widerstand mit einem zweiten Ende, das mit dem ersten Ende des vierten Kondensators verbunden ist;
- eine Zener-Diode mit einem negativen Ende, das mit dem zweiten Ende des dritten Kondensators verbunden ist;
- einen zweiten Transistor mit einem Ausgangsende, das mit einem positiven Ende der dritten Diode verbunden ist, mit einem Steuerende, das mit einem positiven Ende der Zener-Diode und einem ersten Anschluss des vierten Widerstands verbunden ist, und mit einem Eingangsende, das mit dem ersten Ende des vierten Kondensators verbunden ist; und
- einen Induktor, der mit einem negativen Ende der vierten Diode und mit Masse verbunden ist.
6. LED-Treiberschaltung nach einem der Ansprüche 1 bis 5, wobei das DIP-Schaltermodul (106) Folgendes umfasst:
- einen fünften Widerstand mit einem zweiten Ende, das mit dem Steuermodul (107) verbunden ist;
- einen sechsten Widerstand mit einem ersten Ende, das mit einem ersten Ende des fünften Widerstands und mit dem zweiten Spannungsabfallmodul (105) verbunden ist, und mit einem zweiten Ende, das mit dem Steuermodul (107) verbunden ist;
- einen ersten DIP-Schalter mit einem ersten Ende, das mit dem zweiten Ende des fünften Widerstands verbunden ist, und mit einem zweiten Ende, das mit Masse verbunden ist. und
- einen zweiten DIP-Schalter mit einem ersten Ende, das mit dem zweiten Ende des sechsten Widerstands verbunden ist, und mit einem zweiten Ende, das mit Masse verbunden ist.
7. LED-Treiberschaltung nach einem der Ansprüche 1 bis 6, wobei das Steuermodul (107) Folgendes umfasst: einen Hauptsteuerchip mit einem Eingangsende, das mit dem zweiten Spannungsabfallmodul

(105) verbunden ist, einem ersten Empfängerende und einem zweiten Empfängerende, die mit dem DIP-Schaltermodul (106) verbunden sind, einem Steuerende, das mit dem Konstantstrom-Treibermodul (103) verbunden ist, einem Eingangsende, das mit dem Hilfswicklungsmodul (108) verbunden ist, und einem Masseende, das mit Masse verbunden ist.

8. Treibervorrichtung, **dadurch gekennzeichnet, dass** sie ein Lademodul (104) und die LED-Treiberschaltung nach einem der Ansprüche 1 bis 7 umfasst.

9. Treibervorrichtung nach Anspruch 8, wobei das Lademodul (104) ferner Folgendes umfasst:

eine zweite Diode mit einem positiven Ende, das mit dem Konstantstrom-Treibermodul (103) verbunden ist;
einen ersten Kondensator mit einem ersten Ende, das mit einem negativen Ende der zweiten Diode verbunden ist;
einen zweiten Widerstand mit einem ersten Ende, das mit dem negativen Ende der zweiten Diode verbunden ist; und
eine Leuchtdiode mit einem ersten Ende, das mit dem negativen Ende der zweiten Diode verbunden ist, und einem zweiten Ende, das sowohl mit einem zweiten Ende des ersten Kondensators als auch mit einem zweiten Ende des zweiten Widerstands verbunden ist.

Revendications

1. Circuit de pilotage de diodes électroluminescentes, DEL, comprenant :

un premier module de chute de tension (102) pour une connexion à une source d'alimentation (101), et configuré pour convertir une tension d'un courant continu ;
un module de pilotage à courant constant (103), connecté au premier module de chute de tension (102), et configuré pour recevoir la tension de courant continu convertie pour piloter un module de chargement (104) ;
un module d'enroulement auxiliaire (108), connecté au premier module de chute de tension (102) et au module de pilotage à courant constant (103), et configuré pour recevoir la tension de courant continu convertie et pour délivrer corrélativement en sortie un niveau de tension réel ;
caractérisé en ce que le circuit de pilotage de DEL comprend en outre :

un deuxième module de chute de tension

(105), connecté au premier module de chute de tension (102), et configuré pour hacher la tension de courant continu convertie et pour délivrer corrélativement en sortie une tension hachée ;

un module de commutateur à boîtier à double rangée de connexions, DIP (106), connecté au deuxième module de chute de tension (105), et configuré pour recevoir la tension hachée pour l'alimentation du module de commutateur DIP, pour sélectionner un niveau de courant prédéterminé, et pour délivrer en sortie un signal électrique ; et

un module de commande (107), connecté au module de commutateur DIP (106), au deuxième module de chute de tension (105), au module d'enroulement auxiliaire (108) et au module de pilotage à courant constant (103), dans lequel ledit module de commande (107) est agencé pour recevoir ledit signal électrique, la tension hachée pour l'alimentation du module de commande, et pour identifier le niveau de courant défini par le module de commutateur DIP et délivrer en sortie un signal pulsé correspondant qui correspond au signal électrique, ledit signal pulsé étant pour la commande du module de pilotage à courant constant (103), et ledit module de commande (107) est configuré pour calculer un niveau de tension requis et pour déterminer un statut de fonctionnement du module de chargement (104) sur la base d'une relation de niveau de tension entre le niveau de tension requis et le niveau de tension réel ;

dans lequel ledit module de commande (107) est configuré pour déterminer que le statut de fonctionnement du module de chargement (104) est sous un statut de fonctionnement normal, lorsque le niveau de tension réel est inférieur au niveau de tension requis, et pour déterminer que le statut de fonctionnement du module de chargement (104) est un statut de fonctionnement en pause, lorsque le niveau de tension réel est supérieur au niveau de tension requis.

2. Circuit de pilotage de DEL selon la revendication 1, dans lequel le premier module de chute de tension (102) comprend :

une puce de chute de tension, ayant une borne d'entrée pour une connexion à la source d'alimentation (101), ayant une borne de sortie connectée au module d'enroulement auxiliaire (108), et ayant une borne de masse connectée à la masse ;

- un deuxième condensateur, ayant une première borne connectée au module d'enroulement auxiliaire (108) ; et
 un cinquième dispositif à diode, ayant une borne négative connectée à la masse, et ayant une borne positive connectée à une deuxième borne du deuxième condensateur.
3. Circuit de pilotage de DEL selon l'une quelconque des revendications 1 à 2, dans lequel le module de pilotage à courant constant (103) comprend :
- une puce de pilotage, ayant une borne d'entrée connectée au premier module de chute de tension (102), ayant une borne de commande connectée au module de commande (107), et une borne de masse connectée à la masse ;
 un premier transistor, ayant une borne d'entrée connectée à une borne de sortie de la puce de pilotage, et ayant une borne de sortie connectée au module de chargement (104) ;
 une première diode, ayant une borne négative connectée à une borne de pilotage de la puce de pilotage, et ayant une borne positive connectée à une borne de commande borne du premier transistor ; et
 une première résistance, ayant une première borne connectée à la borne de sortie de la puce de pilotage, et ayant une deuxième borne connectée à la masse.
4. Circuit de pilotage de DEL selon l'une quelconque des revendications 1 à 3, dans lequel le deuxième module de chute de tension (105) comprend une puce de chute de tension, ayant une borne d'entrée connectée au premier module de chute de tension (102), ayant une borne de sortie connectée au module de commutateur DIP (106), et ayant une borne de masse connectée à la masse.
5. Circuit de pilotage de DEL selon l'une quelconque des revendications 1 à 4, dans lequel le module d'enroulement auxiliaire (108) comprend :
- une troisième diode, ayant une borne négative connectée au premier module de chute de tension (102) ;
 une quatrième diode ;
 un troisième condensateur, ayant une première borne connectée au premier module de chute de tension (102) ;
 un quatrième condensateur, ayant une première borne connectée à une borne positive de la quatrième diode, et ayant une deuxième borne connectée à la deuxième borne du troisième condensateur ;
 une quatrième résistance, ayant une deuxième borne connectée à la première borne du qua-
- trième condensateur ;
 une diode Zener, ayant une borne négative connectée à une deuxième borne du troisième condensateur ;
 un deuxième transistor, ayant une borne de sortie connectée à une borne positive de la troisième diode, ayant une borne de commande connectée à une borne positive de la diode Zener et à une première borne de la quatrième résistance, et ayant une borne d'entrée connectée à la première borne du quatrième condensateur ; et
 un inducteur, connecté à une borne négative de la quatrième diode et à la masse.
6. Circuit de pilotage de DEL selon l'une quelconque des revendications 1 à 5, dans lequel le module de commutateur DIP (106) comprend :
- une cinquième résistance, ayant une deuxième borne connectée au module de commande (107) ;
 une sixième résistance, ayant une première borne connectée à une première borne de la cinquième résistance et au deuxième module de chute de tension (105), et ayant une deuxième borne connectée au module de commande (107) ;
 un premier commutateur DIP, ayant une première borne connectée à la deuxième borne de la cinquième résistance, et ayant une deuxième borne connectée à la masse ; et
 un deuxième commutateur DIP, ayant une première borne connectée à la deuxième borne de la sixième résistance, et ayant une deuxième borne connectée à la masse.
7. Circuit de pilotage de DEL selon l'une quelconque des revendications 1 à 6, dans lequel le module de commande (107) comprend une puce de commande principale qui possède une borne d'entrée connectée au deuxième module de chute de tension (105), possède une première borne réceptrice et une deuxième borne réceptrice connectées au module de commutateur DIP (106), possède une borne de commande connectée au module de pilotage à courant constant (103), possède une borne d'entrée connectée au module d'enroulement auxiliaire (108), et possède une borne de masse connectée à la masse.
8. Dispositif de pilotage, **caractérisé par le fait qu'il** comprend un module de chargement (104) et le circuit de pilotage de DEL selon l'une quelconque des revendications 1 à 7.
9. Dispositif de pilotage selon la revendication 8, dans lequel le module de chargement (104) comprend en

autre :

une deuxième diode, ayant une borne positive connectée au module de pilotage à courant constant (103) ; 5
un premier condensateur, ayant une première borne connectée à une borne négative de la deuxième diode ;
une deuxième résistance, ayant une première borne connectée à la borne négative de la deuxième diode ; et 10
une diode électroluminescente, ayant une première borne connectée à la borne négative de la deuxième diode, et ayant une deuxième borne connectée à la fois à une deuxième borne du premier condensateur et à une deuxième borne de la deuxième résistance. 15

20

25

30

35

40

45

50

55

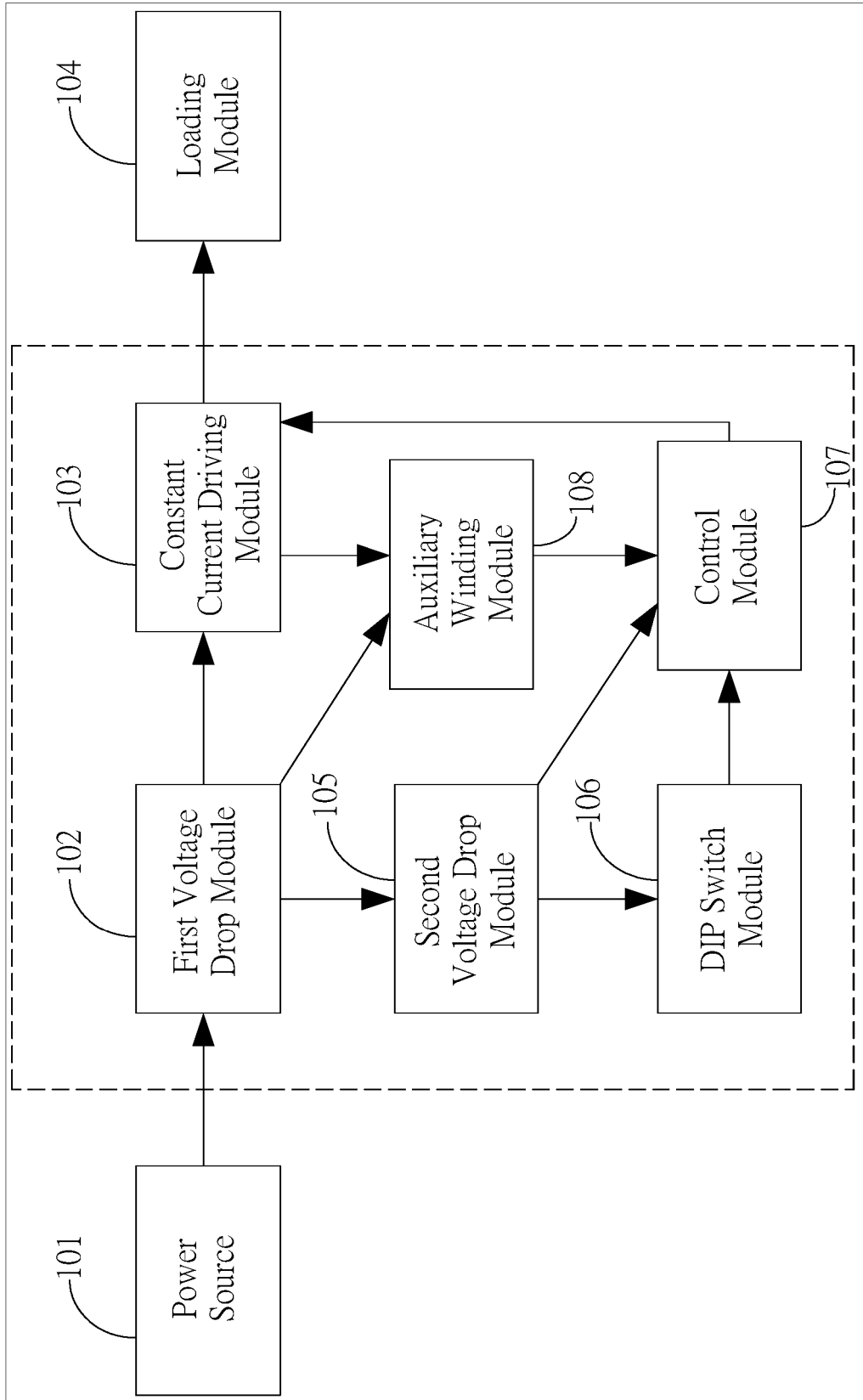

FIG. 1

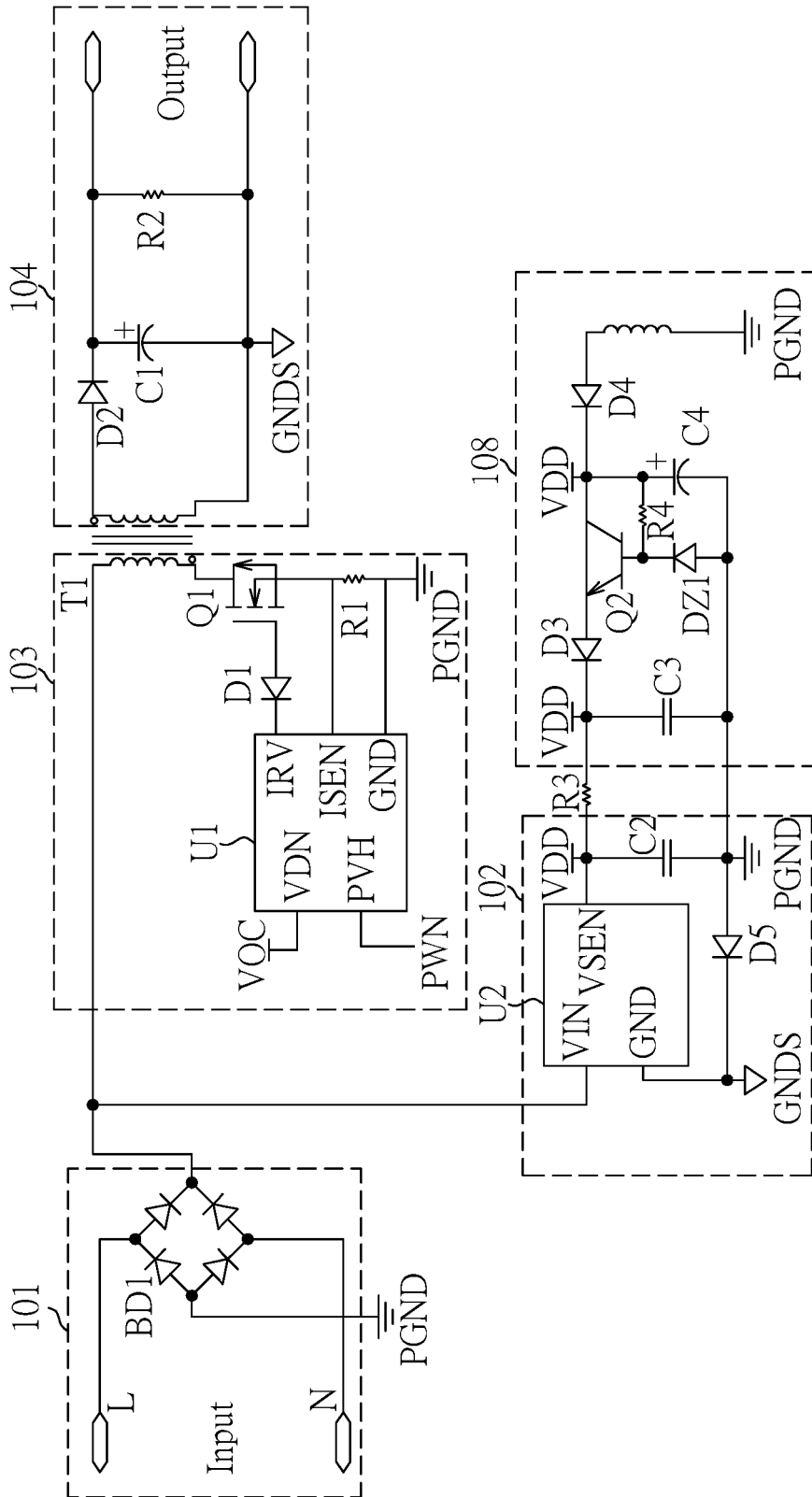

FIG. 2

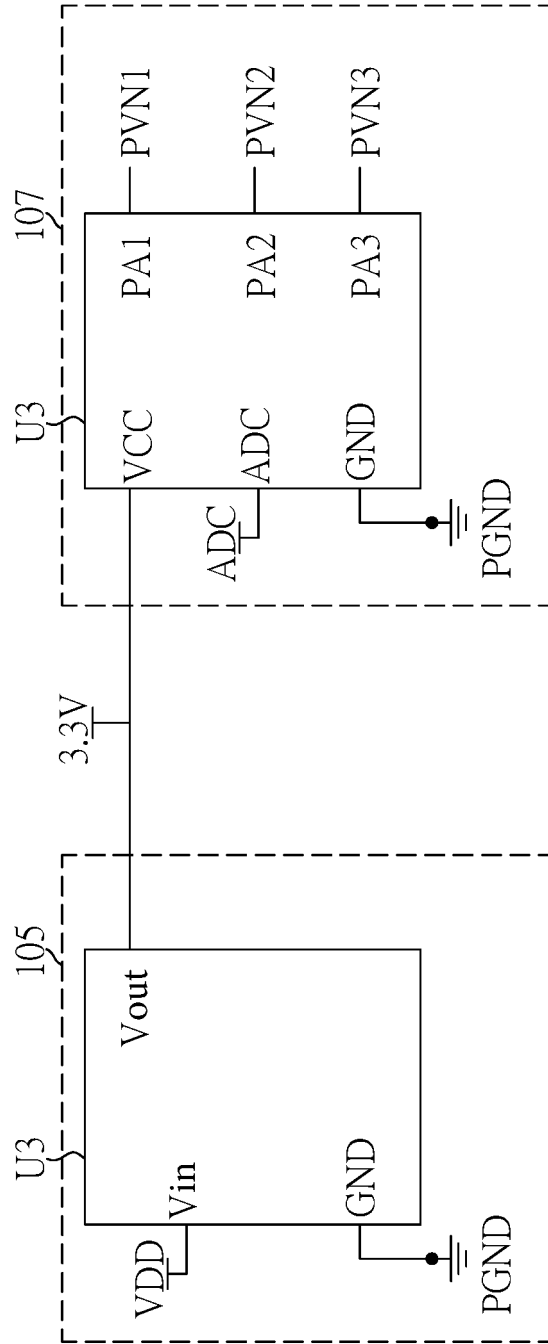

FIG. 3

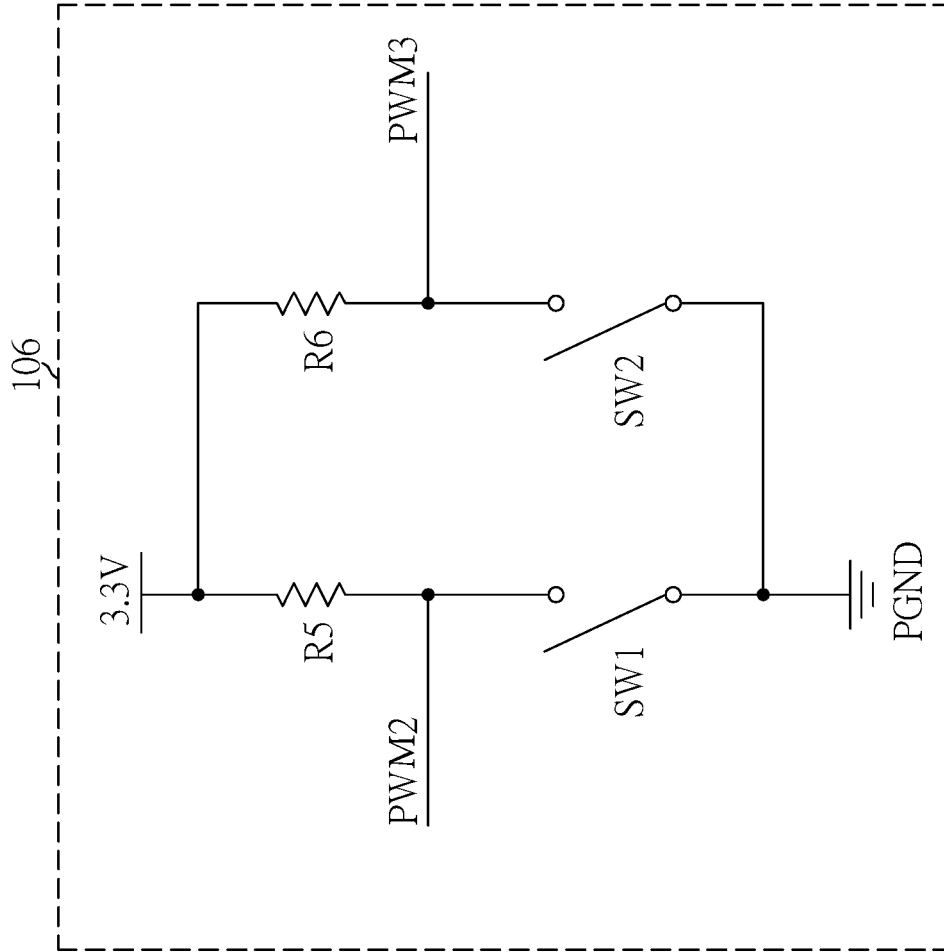

FIG. 4

REFERENCES CITED IN THE DESCRIPTION

This list of references cited by the applicant is for the reader's convenience only. It does not form part of the European patent document. Even though great care has been taken in compiling the references, errors or omissions cannot be excluded and the EPO disclaims all liability in this regard.

Patent documents cited in the description

- US 2014239810 A [0003]