



- (51) **International Patent Classification:**
H04N 1/64 (2006.01) H04N 9/64 (2006.01)
H04N 9/67 (2006.01)
- (21) **International Application Number:**
PCT/US2016/061712
- (22) **International Filing Date:**
11 November 2016 (11.11.2016)
- (25) **Filing Language:** English
- (26) **Publication Language:** English
- (30) **Priority Data:**
62/254,101 11 November 2015 (11.11.2015) US
- (71) **Applicant:** APPLE INC. [US/US]; 1 Infinite Loop, M/S 169-3IPL, Cupertino, California 95014 (US).
- (72) **Inventors:** TOURAPIS, Alexandros; 1 Infinite Loop, M/s 169-31PL, Cupertino, CA 95014 (US). SINGER, David, W.; 1 Infinite Loop, M/s 169-31PL, Cupertino, CA 95014 (US). WU, Hsi-Jung; 1 Infinite Loop, M/s 169-31PL, Cupertino, CA 95014 (US). SU, Yeping; 1 Infinite Loop, Ms 38-1IMG, Cupertino, CA 95014 (US).

- (74) **Agents:** HAILS, Robert, L. et al.; BAKER HOSTETLER LLP, Washington Square, Suite 1100, 1050 Connecticut Avenue N.W., Washington, DC 20036-5304 (US).
- (81) **Designated States** (unless otherwise indicated, for every kind of national protection available): AE, AG, AL, AM, AO, AT, AU, AZ, BA, BB, BG, BH, BN, BR, BW, BY, BZ, CA, CH, CL, CN, CO, CR, CU, CZ, DE, DJ, DK, DM, DO, DZ, EC, EE, EG, ES, FI, GB, GD, GE, GH, GM, GT, HN, HR, HU, ID, IL, IN, IR, IS, JP, KE, KG, KN, KP, KR, KW, KZ, LA, LC, LK, LR, LS, LU, LY, MA, MD, ME, MG, MK, MN, MW, MX, MY, MZ, NA, NG, NI, NO, NZ, OM, PA, PE, PG, PH, PL, PT, QA, RO, RS, RU, RW, SA, SC, SD, SE, SG, SK, SL, SM, ST, SV, SY, TH, TJ, TM, TN, TR, TT, TZ, UA, UG, US, UZ, VC, VN, ZA, ZM, ZW.
- (84) **Designated States** (unless otherwise indicated, for every kind of regional protection available): ARIPO (BW, GH, GM, KE, LR, LS, MW, MZ, NA, RW, SD, SL, ST, SZ, TZ, UG, ZM, ZW), Eurasian (AM, AZ, BY, KG, KZ, RU, TJ, TM), European (AL, AT, BE, BG, CH, CY, CZ, DE, DK, EE, ES, FI, FR, GB, GR, HR, HU, IE, IS, IT, LT, LU, LV, MC, MK, MT, NL, NO, PL, PT, RO, RS, SE, SI, SK, SM, TR), OAPI (BF, BJ, CF, CG, CI, CM, GA, GN, GQ, GW, KM, ML, MR, NE, SN, TD, TG).

[Continued on next page]

(54) **Title:** ADAPTIVE CHROMA DOWNSAMPLING AND COLOR SPACE CONVERSION TECHNIQUES

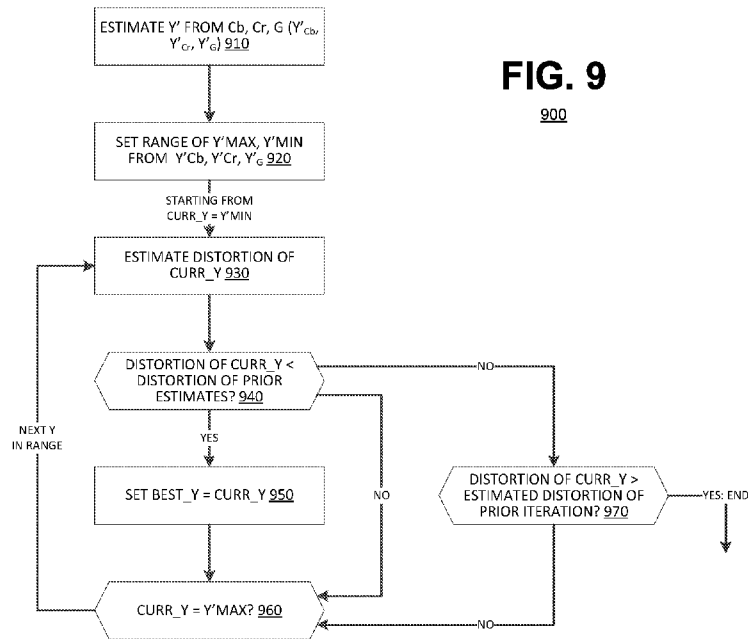

(57) **Abstract:** Techniques for selecting a luminance value for color space conversion are disclosed. Techniques include determining values for Cb and Cr from values for R', G', and B'; producing a reconstructed Cb* value and a reconstructed Cr* value by processing the Cb and Cr values; and determining a plurality of Y' value options from the values for Cb* and Cr*. A Y' output value may be selected based on the plurality of Y' value options.

WO 2017/083784 A1

Published:

— *with international search report (Art. 21(3))*

**ADAPTIVE CHROMA DOWNSAMPLING AND COLOR SPACE CONVERSION
TECHNIQUES**

Inventors: Alexandros Tourapis
David W. Singer
Hsi-Jung Wu
Yeping Su

CROSS REFERENCE TO RELATED APPLICATION

- [01] This application claims benefit of Provisional U.S. patent application no. 62/254,101, filed November 11, 2015, the contents of which is incorporated herein by reference in its entirety.

BACKGROUND

- [02] This application relates to digital image processing techniques.
- [03] The present invention relates to video coding techniques. Video distribution systems include a video source and at least one receiving device. The video content may be distributed over a network or over fixed media. To keep complexity and cost low, video content is typically limited in terms of its video format representation, e.g., 8-10 bit signal representations and 4:2:0 color format, as well as its content characteristics, e.g. dynamic range and colour gamut. Recent advances in display technology, however, have opened the door for the use of more sophisticated content (also referred to as higher quality content), including content characterized as High Dynamic Range (HDR) and/or wide color gamut (WCG), as well as content with increased spatial and/or temporal resolution. This higher quality content is typically converted to a representation appropriate for processing and distribution format using a Transfer Function (TF) that is followed by a quantization to a particular fixed bit-depth precision (e.g. 8 or 10 bits). The conversion may also include a color space conversion process, in a space that may be friendlier for encoding, as well as color format conversion, e.g. converting data from 4:4:4 or 4:2:2 to a representation with fewer chroma samples (e.g. 4:2:2 and 4:2:0), before encoding for distribution using a video compression system. These steps can introduce aliasing, banding and other artifacts that may impact and substantially degrade the quality of the video content when decoded and displayed.

BRIEF DESCRIPTION OF THE DRAWINGS

- [04] FIG. 1 is a block diagram of an example of a video communication system.
- [05] FIG. 2 is a block diagram of an example video coding engine.
- [06] FIG. 3 is a block diagram of an example color format conversion for encoding.
- [07] FIG. 4 is a flowchart for an example process for choosing a downsample filter.
- [08] FIG. 5 is a flowchart for an example process for a pixel-by-pixel selection of downsample filters.
- [09] FIG. 6 is a flowchart for an example process for selecting a downsample filter.
- [10] FIG. 7 is an example dataflow diagram for converting R'G'B' to Y'CrCb.
- [11] FIG. 8 is an example dataflow diagram for converting R'G'B' to YCrCb.
- [12] FIG. 9 illustrates a method according to an embodiment of the present disclosure.
- [13] FIG. 10 illustrates a method according to an embodiment of the present disclosure.

DETAILED DESCRIPTION

- [14] Techniques for selecting a luminance value for color space conversion are disclosed. These techniques may be useful, for example, in closed-loop pixel format conversion. Techniques include determining values for Cb and Cr from values for R', G', and B'; producing a reconstructed Cb* value and a reconstructed Cr* value by processing the Cb and Cr values; and determining a plurality of Y' value options from the values for Cb* and Cr*. A Y' output value may be selected based on the plurality of Y' value options.
- [15] Video and image compression systems often operate in a color space/representation different than the capture color space/representation and/or display color space/representation. For example, video may be captured in an RGB color space but will be translated to a Y'CbCr color space. This is done to maximize the compression properties of the video signal, by essentially exploiting redundancies and moving into color spaces that may have better compression, homogeneity, and error masking properties.
- [16] Commonly, decoders and receivers conventionally have a limited or known number of filters, including those implemented for upsampling the decoded data to fit a particular display. However, encoders conventionally optimize filter selection, including downsampling filters,

without consideration for the target device or devices. Accordingly, improved techniques for filter selection and color space conversion are provided herein, to be carried out in the image/video processing chain.

- [17] Therefore, a need is perceived in the art for improved encoding processes, and in some instances matching improved decoding processes, capable of handling higher quality content and taking into consideration the captured content and the anticipated decoding operations that results in an improved experience at the decoder compared to conventional encoders.
- [18] FIG. 1 is a block diagram of an example of a video communication system. Source video 102 is transmitted by a transmitter 120 through a communications channel 110 to a receiver 122 to be output as recovered video 118. Transmitter 120 may comprise a pre-processor 104 that outputs pre-processed video data to coding engine 108. A controller 106 may manage pre-processing and encoding operations where applicable. After transmission through communications channel 110, receiver 122 may recover and decode the received encoded video at decoder 112. The post-processing may be applied to the decoded video at post-processor 116. A controller 114 may manage decoding and post-processing where applicable. Controllers 106 and 114 may include a computer processor and memory containing processor instructions for controlling elements of the transmitter 120 and receiver 122, respectively. In embodiments where the post-processing is not fixed, pre-process parameters selected by the pre-processor 104 can be included as side information in the encoded bitstream transmitted over channel 110. Then at the receiver, the side information can be extracted from the encoded bitstream, and used to control the post-processor 116.

Encoding Basics

- [19] In video coding systems, a conventional encoder may code a source video sequence into a coded representation that has a smaller bit rate than does the source video and, thereby achieve data compression. A decoder may then invert the coding processes performed by the encoder to retrieve the source video. Coding engine 108 may be a conventional encoder, and decoder 112 may be a conventional decoder.
- [20] A video system may include terminals that communicate via a network. Each of the terminals may receive video data locally and code the video data for transmission to another terminal via the network. In duplex (two-way) communications systems, a terminal at each end will encode

video sourced at that end. Each terminal may then receive the coded video data of the other terminal from the network, decode the coded data and display or store the recovered video data. Video terminals may include personal computers (both desktop and laptop computers), tablet computers, handheld computing devices, computer servers, television devices, media players, and/or dedicated video conferencing equipment.

- [21] An encoder system may accept a source video sequence and may code the source video as coded video, which typically has a much lower bit rate than the source video. A channel delivers the coded video data output from the coding engine to the decoder.
- [22] The encoder system may output the coded video data to the channel, which may be a storage device, such as an optical, magnetic or electrical storage device, or a communication channel formed by computer network or a communication network for example either a wired or wireless network.
- [23] A decoder system may retrieve the coded video data from the channel, invert the coding operations performed by the encoder system, and output decoded video data to an associated display device.
- [24] FIG. 1 is a block diagram of an example of a video communication system. With reference again to FIG. 1, a simplex (one-way) terminal may be the transmitter 120. The transmitter 120 may receive image data from a video source 102 that provides video data as a sequence of video images. The video source may be a camera that may include an image sensor to capture an optical image. Pre-processor 104 functions applied to source video may include converting the format conversion as well as image quality enhancements. For example, the captured image data may be captured in the RGB color domain. The captured image data may also be in the linear domain or be in a sensor/camera specific transfer function that may have to be converted to another domain (e.g. back to linear). The captured data, given the characteristics of the imaging sensor, might also require a de-mosaicing algorithm to be applied in order to convert them to a full resolution color image. Video may also have been processed by other steps that follow the capture process, and may include an automatic or manual (guided) color grading process, as well as other steps such as cropping, rescaling, and frame rate and bitdepth conversion. The video source may alternatively be a storage device that stores video data authored from other sources (for example, computer graphics or the like). The video data will

conventionally be converted to a non-constant luminance (NCL) representation, i.e. commonly referred to as YCbCr, or Y'CbCr, or YUV, based on particular color primaries, e.g. BT.709 or BT.2020, prior to compression operations using a video codec. YCbCr and Y'CbCr would be used interchangeably throughout this document.

- [25] A pre-processor 104 receives a sequence of source video data and performs pre-processing operations that condition the source video for subsequent coding. Video pre-processing may be performed upon source video data to render video coding more efficient by performing video processing operations on video pictures such as spatial and or temporal de-noising filtering, bilateral filtering, rescaling or other kinds of processing operations that may improve the efficiency of the coding operations performed by the encoder.
- [26] A coding engine 108 performs encoding operations on the converted input signal. The encoder may exploit temporal and spatial redundancies in the video data. The encoder may perform motion compensated predictive coding. The coding engine may operate according to a predetermined protocol, such as H.263, H.264/AVC, H.265/HEVC, VP8, VP9, or MPEG-2 among others. The coded video data output from the coding engine may therefore conform to a syntax specified by the protocol being used. FIG. 2 is a block diagram of an example video compression system, and is one example of coding engine 108. The coding engine 108 may include an encoding pipeline further including a transform 206 unit, a quantizer 208 unit, an entropy coder 210, a motion prediction 214 unit, which may include both intra-frame prediction and motion compensated prediction, and a subtractor 204. The transform 206 unit may convert the processed data into an array of transform coefficients, for example, by a discrete cosine transform (DCT) process or wavelet process. The transform coefficients can then be sent to the quantizer 208 unit where they may be divided by a quantization parameter. Information from the motion prediction 214 unit as well as the quantized data may then be sent to the entropy coder 210 where they may be coded by run-value, run-length, or other entropy coding for compression.
- [27] A decode unit 220 decodes the coded video data from the encoder by performing the inverse operations as performed at the coding engine. It may also include an in-loop post-processing 218 unit that may include processes that try to compensate artifacts that may have been introduced by the characteristics of the predictive, transform coding, and quantization processes. In-loop post-processing could include techniques such as in-loop deblocking, sample adaptive offset (SAO)

processing, the adaptive loop filtering (ALF) process, or other techniques such as de-banding, sharpening, dithering, and de-ringing among others. After in-loop post-processing, pictures are commonly sent to a reference picture cache 216 and/or a display. A reference picture cache 216 stores previously decoded pictures and other pictures that may be used by the motion prediction unit 214 as reference pictures for future encoding operations.

- [28] A channel coder (not depicted) may format coded video data for transmission in a channel, and may add error detection or correction to identify or compensate for errors induced during transmission through the channel. The channel itself may operate according to predetermined communication protocols. The transmitter may format the coded video data according to the protocols that are appropriate for the channel and may output the coded video data to the channel.
- [29] A controller 106 may manage pre-processing and encoding operations where applicable.

Color Space Conversion Optimization

- [30] Conventionally, video captured in the RGB space will be converted to the Y'CbCr space, or sometimes called YCbCr, YUV, or Y'UV, via a transform function. If the source video employs different primaries than the Y'CbCr target space, color conversion of primaries may occur as a preliminary step (for example, as may occur from Rec. ITU-R BT.709 or P3 to Rec. ITU-R BT.2020 primaries). The RGB to Y'CbCr conversion may be accomplished commonly with a 3x3 matrix represented as $M[x,y]$. This $M[x,y]$ matrix relates to the color primaries and color volume that a particular R, G, and B color space is desired to encompass. Alternatively, just a 1x3 matrix, that corresponds to one of the rows of $M[x,y]$, e.g. the first row, may be used to convert a first component (commonly the Y), followed by a subsequent step to generate all other components given the previous conversions. For example, in the non-constant luminance representation of Y'CbCr as is specified in standard specifications such as Rec. ITU-R BT.709 and Rec. ITU-R BT.2020 among others, Y' may be calculated as $M[1,1] * R' + M[1,2] * G' + M[1,3] * B'$ where R', G', and B' are the red (R), green (G), and blue (B) samples of the captured RGB image data converted from a linear into a non-linear representation using a pre-specified transfer function such as the power law transfer function specified in Rec. ITU-R BT.709 and Rec. ITU-R BT.2020 or the transfer function specified in ST 2084 (PQ) and Rec. ITU-R BT.2100, among others, and $M[1,1]$, $M[1,2]$, $M[1,3]$ appropriate transform coefficients

that may relate the conversion of R, G, and B data back to a luminance (Y or L) signal in the XYZ color space (CIE 1976).

[31] Then, the Cb and Cr components of the image data may be calculated using either the Y' signal and some of the other transformed components, commonly B' for Cb and R' for Cr, or using only the R', G', and B' values and appropriately defined matrix M coefficient values. In the constant luminance domain, Y' is computed as $Y' = (M[1,1] * R + M[1,2] * G + M[1,3] * B)'$. In this scenario, the transfer function is only applied at the end of the transformation process from R, G, and B to Y, where now these color components are in the linear domain. In some embodiments, Y' of the non-constant luminance case may be referred to as Y_{nc}' , and the constant luminance may be referred to as Y_{cl}' to differentiate between the two. In other embodiments, Y' may refer to both with an indication to differentiate between the two if needed. Commonly, for the constant luminance conversion, only a 1x3 matrix is used to create the Y' component. The Cb and Cr components are then computed based on this value and the B and R quantities after the same transfer function is applied onto them, resulting in B' and R' values.

[32] According to an embodiment, in the non-constant luminance domain, Cb may be calculated as $Cb = (B' - Y') * Sb$ and Cr is calculated as $Cr = (R' - Y') * Sr$. Sb and Sr relate to the color primaries that a particular R, G, and B color space is desired to contain. In the constant luminance domain, commonly if $B' - Y'$ is less than or equal to zero, Cb is calculated as $Cb = (B' - Y') * Nb$, otherwise Cb is calculated as $Cb = (B' - Y') * Sb$. Similarly, if $R' - Y'$ is less than or equal to zero, Cr is calculated as $Cr = (R' - Y') * Nr$, otherwise Cr is calculated as $Cr = (R' - Y') * Sr$. It is possible to set $Nb = Sb$ and $Nr = Sr$, but these values are commonly selected given the characteristics of the color space and the transfer function involved in the conversion. In particular, for both cases, i.e. constant and non-constant luminance, it is intended that the Cb and Cr values are always within [-0.5, 0.5]. Given that, one can easily compute the minimum and maximum value that may result for Cb and Cr respectively and determine those quantities. For example, for the non-constant luminance case, Cb may be computed as:

$$B' - Y' = -M[1,1] * R' - M[1,2] * G' + (1 - M[1,3]) * B'$$

[33] The maximum value for this derivation is $(1 - M[1,3])$. Similarly the minimum value is equal to $-(M[1,1] + M[1,2])$. Furthermore, $M[1,1] + M[1,2] + M[1,3] = 1$ thus $-(M[1,1] + M[1,2]) = -(1 - M[1,3])$. Therefore the range, before normalization is $[-(1 - M[1,3]) : (1 - M[1,3])]$.

Given this, $S_b = 1 / (2 * (1 - M[1,3]))$. A similar derivation can be applied for the Cr component and Sr.

[34] Similarly, for constant luminance:

$$B' - Y' = B' - (M[1,1] * R + M[1,2] * G + M[1,3] * B)'$$

[35] In this case, the maximum value would be $1 - (M[1,3])'$ and the minimum value would be $-(1 - M[1,3])'$. The range is asymmetric, and transfer function dependent. Given these values one can derive the Nb and Sb quantities, and similarly can also compute the Nr and Sr quantities for Cr.

[36] In an embodiment, and for the constant luminance case, the Cb/Cr components may be alternatively calculated according to the following:

$$Cb_temp = (B - Y) * S_b$$

$$Cr_temp = (R - Y) * S_r$$

where Y here is in the linear space, and also corresponds to the actual luminance information of the signal. Sb and Sr are quantities that try to preserve the color information as much as possible, given a subsequent quantization process. Then:

$$Cb = \text{sign}(Cb_temp) * \text{TFcb}(\text{abs}(Cb_temp))$$

$$Cr = \text{sign}(Cr_temp) * \text{TFcr}(\text{abs}(Cr_temp))$$

Where the TFcb/ITFcb and TFcr/ITFcr correspond to a particular transfer function and its inverse applied to each color component. Note that this transfer function does not need to be the same as the transfer function applied for generating the Y' component. The TF could be more subjectively “tuned” for color information, or the same TF that is applied on Y may be applied.

[37] Similar considerations for deriving Sb and Sr need to be applied as discussed previously, i.e. the Cb and Cr quantities may need to remain within the [-0.5, 0.5] range after conversion.

[38] In an embodiment, and for the non-constant luminance case, the Cb/Cr components may be calculated according to the following:

[39] First calculate the Y component as $Y' = M[1,1] * R' + M[1,2] * G' + M[1,3] * B'$. Y' is then converted to an inverted transform form Y_ncl , $Y_ncl = \text{ITF}(Y')$. It should be noted that commonly, i.e. unless the TF was a linear TF, $Y_ncl \neq Y$. Then:

$$Cb_temp = (B - ITF(Y')) * Sb$$

$$Cr_temp = (R - ITF(Y')) * Sr$$

And as above,

$$Cb = \text{sign}(Cb_temp) * \text{TFcb}(\text{abs}(Cb_temp))$$

$$Cr = \text{sign}(Cr_temp) * \text{TFcr}(\text{abs}(Cr_temp))$$

with TFcb and TFcr being appropriate transfer functions.

- [40] Similar considerations for deriving Sb and Sr need to be applied as previously discussed, i.e. the Cb and Cr quantities should remain within the [-0.5, 0.5] range.
- [41] According to an embodiment, Sb may be calculated as $1/(2*(1-M(1,3)))$ and Sr may be calculated as $1/(2*(1-M(1,1)))$.
- [42] FIG. 3 is a block diagram of an example color format conversion for encoding. Once the color space conversion is completed, quantization and subsampling operations are conventionally performed on the image data in the Y'CbCr color space prior to delivering the data onto an encoder or pre-processing system. In FIG. 3 color space conversion can be performed as described above in converter 302, followed by quantizer 204 and downsampler 305. According to an embodiment, the quantized value of Y' (Yq) may be calculated as $Qy(Y')$ where $Qy(x)$ represents the quantization function for a variable x. If a downsampling process is used, e.g. from 4:4:4 to 4:2:2 or 4:2:0, or from 4:2:2 to 4:2:0, the downsampled versions of Cb and Cr need to be generated using a particular downsampling process. This process can be represented as $\text{Down}(QCb(Cb))$ and $\text{Down}(QCr(Cr))$ respectively where $\text{Down}(x)$ is the down sampling function. These steps are commonly inverted prior to display or some other processing that may be desirable. After these processes are completed, and if these data are then passed into an encoder then encoding processes are performed directly on such data. For example, the output of downsampler 305 may be input to pre-processor 104 or directly into coding engine 108 where, for example, prediction, DCT or waveform transform, quantization, and other coding processes may be performed.
- [43] Similar functions can be performed inversely as part of decoding operations to generate reconstructed Br', Rr', and Gr'. For example, Yr' may be calculated as $\text{IQ}(YqN)$ where $\text{IQ}(x)$ is the inverse quantization function applied on a variable x. IqN is essentially $\text{Iq} + N$, where N is a

noise that was added during encoding or transmission of the data (e.g. quantization noise). The Cbr and Crr values may be calculated as $IQ(UP(CbqN))$ and $IQ(UP(CrqN))$ respectively where $UP(x)$ is an upsampling function and CbqN and CrqN are the reconstructed chroma data with, similarly, some coding noise also introduced into them due to the coding process.

[44] Then, for the conventional method, Br' may be calculated as $Cbr/Sb + Yr'$ and Rr' may be calculated as $Crr/Sr + Yr'$. Then, solving the above equation for the calculation of Y' for the value of G' , Gr' may be calculated as $(Yr' - M[1,1]*Rr' - M[1,3]*Br')/M[1,2]$.

[45] In the methods presented above, the presented conversion and encoding operations are inverted at the decoder, which may require new inversion methods. In particular, in the constant luminance, the inversion process for generating the B, R, and G components is now performed as follows:

$$Cbr_temp = sign(Cbr) * ITFcb(abs(Cbr))$$

$$Crr_temp = sign(Crr) * ITFcr(abs(Crr))$$

$$Br = Cbr_temp / Sb + Y$$

$$Rr = Crr_temp / Sr + Y$$

$$Gr = (Yr - M[1,1]*Rr - M[1,3]*Br)/M[1,2]$$

[46] Similarly, for the non-constant luminance method:

$$Cbr_temp = sign(Cbr) * ITFcb(abs(Cbr))$$

$$Crr_temp = sign(Crr) * ITFcr(abs(Crr))$$

$$Br = Cbr_temp / Sb + ITF(Y')$$

$$Rr = Crr_temp / Sr + ITF(Y')$$

$$Gr = (Yr - M[1,1]*Rr - M[1,3]*Br)/M[1,2]$$

[47] Similar considerations for deriving Sb and Sr need to be applied as previously discussed, i.e. the Cb and Cr quantities may need to remain within the [-0.5, 0.5] range.

Adaptive Chroma Downsampling

[48] As mentioned above, an important step for preparing content for compression is the conversion of the original video data that may be in a 4:4:4 or 4:2:2 arrangement, in a reduced chroma

resolution space using a chroma downsampling method. Given the characteristics of the chroma signal, such a step could improve compression while also reducing complexity since fewer samples need to be processed during encoding. An adaptive chroma downsampling method, e.g. from 4:4:4 to 4:2:2 or 4:2:0 is described that involves the consideration of N possible downsampling filters, and adaptively selects the “best” filter for each sample position, resulting in improved performance.

- [49] A 4:2:2 format is a luminance-chrominance format where the chrominance channels are downsampled in one dimension, containing a single luminance value for every pixel, but each of the two chrominance channels contain only one value for every other pixel along one dimension of the image. This results in each of the two chrominance channels in a 4:2:2 format containing only one value for every two luma samples along one (typically the horizontal) dimension of the image. A 4:2:0 format is a luminance-chrominance format where the chrominance channels are downsampled in both dimensions, each of the chrominance channels containing only one value for every two luma samples along both dimensions of the image. This results in each chrominance channel in a 4:2:2 format containing a quarter as many values as the luminance channel. A 4:4:4 format is not downsampled and includes three color component values for every pixel.
- [50] FIG. 3 is a block diagram of an example color format conversion for encoding. The color format converter of FIG. 3 may be incorporated as part of the pre-processor 104 of FIG. 1, and may output data in a format appropriate to the coding engine 108. In this example, source video 102 is converted in color space, for example from RGB to any of the 4:4:4 luminance-chrominance formats described herein. Downsample filter selector 204 chooses a chroma downsample filter from a set of downsample filter options as described below regarding FIG. 4. The chosen downsample filter 305 is used to generate pre-processed data 202 from the chosen downsample filter 305.
- [51] FIG. 4 is a flowchart for an example process for choosing a downsample filter. According to an embodiment, the decision of which filter to use for each sample position is based on examining the performance of each filter given a known upsampling filter that would likely be used after decoding (e.g. prior to display, delivery through an interface system etc.). Each filter is evaluated and the one resulting in the least distortion, e.g. sum of square errors (SSE), sum of absolute

differences (SAD), Structural Similarity Index Metric (SSIM), or some other measurement of objective distortion, compared to the original signal can be selected as the best filter. As illustrated in FIG. 4, one of the two chroma channels of an image is input at 402. Controller 410 chooses one of N possible downsampling filters to apply at 404 to the input chroma channel. The result of filtering at 404 is then immediately upsampled with the known or assumed upsampling filter at 406, with the result of the upsampling compared at 408 with the original input chroma channel to produce a distortion estimate at 408. The distortion estimate is sent to the controller for the selected filter. This process is repeated for each of the N possible downsample filters to identify the lowest distortion. The filter corresponding to the lowest distortion is then output as the filter selection 412.

- [52] According to an embodiment, the encoder may target multiple different delivery systems, e.g. different displays. These displays may have different filters. The known filters from these displays could again be considered and evaluated to select the downsampler that results in the best average performance across all the available upsamplers. The various known display upsamplers could be considered with equal weighting, or could be weighted based on the prevalence and importance of each anticipated upsampler.
- [53] An optimal filter may be selected for a frame/picture. Available filters may be evaluated over an entire picture and an optimal filter selected as the filter that results in the best performance over this entire picture. Additionally, smaller units than a picture could be considered. In particular, a picture could be separated in segments, e.g. one or more lines/rows or columns, blocks or tiles etc. For each of these segments, embodiments may generate all possible downsampling versions, upconvert given the available upsamplers, and independently select the filters for each segment. The final downsampled image would be the combination of all individual optimized regions. In a particular embodiment, overlapped regions may be used for optimization. For the overlapping areas a weighted average of the samples could be used for the final reconstruction. Weighting could be based on a distance from the boundaries of each region, or some other criterion that may include an analysis of the image and the characteristics of the filters. For example, if a sample corresponds to an edge and in one region a sharper filter was selected, while also more edge samples are within that region, then that filter may be given higher weighting than a filter in another region with fewer edge samples. Similar considerations may apply if the sample is considered as corresponding to texture or a flat region.

[54] FIG. 5 is flowchart for an example process for a pixel-by-pixel selection of downsample filters. According to an embodiment, optimization could be performed for each individual sample. This may provide a better performance than a scheme based on fixed regions. As shown in FIG. 5:

- a. For a particular region, e.g. an entire or partial picture line, select one downsampling filter as default. At step 510, apply the default filter on all samples to generate an initial filtered region R_f .
- b. For each sample in the region, consider all alternate downsampling filters.
 - i. For example, in step 520, for the current position, filter this position sample given all alternate downsampling filters (e.g. N filters), generating N possible alternative values.
 - ii. Then, given the known upsampling filters that are to be considered, downsample and upsample all positions in image R_f impacted by these up samplers (this essentially depends on the number of taps of the up sampling filters) and this particular sample position. Perform the same for all alternatives while considering all other samples having the same filtered value as the region R_f .
 - iii. Compute the distortion for the impacted region for each applied filter and find the minimum distortion at step 530. The version that has the minimum distortion is declared the current optimal filter for this sample. In step 540, The sample in image R_f , is updated given the corresponding filtered sample in this filtered version.
 - iv. In step 550, unless the end of the region has been reached, increment the position and repeat the filtering operations.
 - v. If the end of the region has been reached, then embodiments may either terminate (based on a distortion threshold or number of iterations), or repeat the entire process for the sample to further optimize the filter selection. This will provide refinement of the selected downsampler given knowledge from all sides of an image.

- [55] Some embodiments may consider not just a single initial filtered region, but multiple given different filters. Then for each of these alternate regions a decision may be made to perform the above optimization given only a subset of the filters. The same regions or differently partitioned regions with some overlapping could be considered as the alternate regions for this process. After the process completes for all of these alternatives, embodiments can then merge the results together. This can be done by merging the outcome from each co-sited sample from the alternative (or intermediate) optimized regions in a variety of ways. In one embodiment, the intermediate outcomes could be averaged together. In an alternative embodiment, these alternatives are now considered as the alternative filter candidates that could be considered for a subsequent optimization step. In this case, the above process is now repeated using these alternatives in the decision process. In this scenario, a new region partitioning may be considered that may be the same as one or more of the initial partitions used or be completely different than the initial partitions considered. Essentially this is now a hierarchical optimization process which can allow us for some form of parallelization, whereas, given the reduced number of filters that now need to be considered in each alternative subset region, the complexity would end up being lower.
- [56] According to an embodiment, the decision for the filters is augmented by signal pre-analysis, such as edge and texture/variance detection. In particular, embodiments can first analyze an image for edges or texture and classify every sample accordingly. Every sample that is classified as an edge or being near an edge could consider only certain filters for downsampling, whereas flat regions or textured regions could consider other filters. Brightness or color characteristics of a sample or pixel could be also considered. Then, the above optimization steps would only consider the appropriate filters given the mode of the sample.
- [57] Consideration of other color components and their characteristics compared to the current component sample can also be made. If a particular filter, for example, was selected for the Cb component, then that filter may likely be the optimal filter for the Cr component filter decision as well. Embodiments may skip filters that performed poorly for one component's sample when evaluating the other component's sample for the same position. If also the characteristics (e.g. edge or texture classification) of the different color component samples match, then it is more than likely that the same filter would be used for both components. This can considerably reduce complexity and speed up the downsampling process.

- [58] The above process could be performed directly on transform domain data (e.g. power law gamma or using a perceptual quantizer based gamma, e.g. ST.2084/PQ), or directly on linear data.
- [59] The process could involve a 4:4:4 to 4:2:2 downsampling, 4:2:2 to 4:2:0, or 4:4:4 to 4:2:0. For the latter case, an embodiment may first perform adaptive downsampling across one direction, e.g. horizontally, followed by adaptive downsampling across the other direction, e.g. vertically. It is also possible that the process may involve 2D downsampling directly and the conversion could be done in a single step for both dimensions.

Filter Optimization

- [60] An encoder may know the filter and transform functions that will be used to upsample the reconstructed image data. Then, with a known upsampling filter, the downsampling filter may be designed to optimize the distortion that will be induced by the upsampling. As previously noted, in an embodiment, the encoder may target multiple different delivery systems, e.g. different displays that may have different filters. The known filters for these displays could be considered and evaluated to select the downsampler that results in the best average performance across all the available upsamplers. The various known display upsamplers could be considered with equal weighting, or could be weighted based on the prevalence and importance of each anticipated upsampler.
- [61] Such optimization can be achieved by choosing an optimal filter based on the Cb/Cr component of the original source data, or some other color representation of the original source data (e.g. R, G, and B or X, Y, Z representations). FIG. 6 is a flowchart for an example process for selecting a downsample filter. In the example of FIG. 6, performing quantization and downsampling on the Cb/Cr component and then performing the inverse functions 620 to reconstruct the Cbr/Crr component using each different available filter, the original Cb/Cr may be compared to the reconstructed Cbr/Crr data to calculate the distortion added during the processing. The data can optionally be converted back to R, G, and B, or X, Y, and Z, and the distortion can be computed in those spaces instead. The filter that best minimizes distortion may then be selected for use in the encoding process.
- [62] As shown in FIG. 6, initially for a portion of the image data, the Cb and Cr components of the portion are encoded using one of the available upsampling filters (block 610). Then the

reconstructed Crr and Cbr components of the portion of the image data are created using the corresponding downsampling filter (block 620). Then the distortion introduced in the encoding and reconstruction process may be calculated by comparing the original Cr/Cb components to the reconstructed Crr/Cbr components (block 630). Once all the available filters have been considered, the filter that results in the lowest distortion will be selected (block 640). The distortion metric used in the encoding decision process may be, for example, the mean or sum of absolute differences (MAD or SAD), the sum of absolute transformed differences (SATD), the mean or sum of square differences/errors (MSE or SSE), the peak signal to noise ratio (PSNR), the structural similarity index (SSIM), or other suitable operations.

- [63] Filter optimization may also occur end to end in different domains. For example, after Cbr and Crr are calculated, data in the RGB or XYZ color space may be calculated based on each of the original Y'CbCr and the recovered Y'rCbCr. Then the filter that minimizes distortion XYZ and XrYrZr may be calculated. This approach may require that embodiments first make a preliminary decision for one color component, e.g. Cr, and using that decision try to optimize the other color component, i.e. Cb. After the optimization of this color component is completed embodiments can go back to Cr and refine it further given the initial joint decision for Cb. This process may iterate multiple times. Iteration may repeat until no further change in performance is observed, or after N steps that may be determined by the user or application. The application, for example, may determine the number of steps adaptively, based for example an overall complexity budget involving the downsampling/upsampling process. The Y' component would also need to be considered in this process, whereas characteristics and quantization on the Y' component, as discussed in other sections of this application, may also be considered. Distortion in this extended color space could again be based on MAD, SAD, SATD, SSE, or PSNR. Distortion could be computed in the linear space or using an appropriately defined transfer function. Distortion from each color component in this extended space could be combined using an average or a weighted average, based on an importance of each color component, to generate a single distortion measurement. Weighting could also include content characteristics such as local and global brightness, whether the sample corresponds or is near an edge, texture, or a flat region among others.
- [64] Filters may be chosen based on comparisons of an original and a reconstructed sequence, scene, image, slice, block, pixel, or other portion of image data.

- [65] Similarly, with known filters, the color transform matrix (M) can be optimized in a similar manner as described above to minimize distortion.
- [66] With known upsampling and downsampling filters, and when a fixed bit-depth for quantization is used, the quantization parameters used in the quantization transform $Q()$ may be optimized in a similar manner as described to minimize distortion. Such optimization may also take into consideration quantization boundaries and deadzones.
- [67] Information about the selected optimizations may be sent from the encoder to a receiver or decoder as part of encoding hints data transmitted with the encoded data. Such encoding hints data may include the transform matrix used in color transform, the parameters used in the quantization transform, and information about the filters used in the optimization process among others. A more complex process may also include aspects of the actual video encoding and decoding, i.e. through an initial coding pass using a codec such as H.264 or H.265. Such information could be fed back to the filter optimization stage to further refine the downsampling process. For example, if it is known that the encoding would be at a particular bitrate and chroma precision below a certain level will be lost due to quantization, that could be considered during the filtering process to either reduce complexity or improve quality. Noise characteristics of the signal, as well as the denoising impact of the filters and/or of the encoding process, may also be considered for the optimization and the filtering process.
- [68] It should be noted that all the operations above could be applied not only on non-constant luminance $Y'CbCr$ data, but also on constant luminance $Y'CbCr$ data, or other color spaces such as $Y'u'v'$ (CIE 1976), $Y'u''v''$, IPT, and ICtCp color spaces, or other color spaces that may be appropriate for video encoding.

Chroma Re-sampling

- [69] Conventional color transform techniques use a non-linear transfer function (the transfer domain). This is done in an effort to perform an initial basic compression of the signal to a fixed bitdepth using some subjectively defined process (the transfer function). However, operations performed on color components in the transfer domain may result in a loss of precision and may also introduce objectionable distortion, given the non-linearity of the transform function. These problems could be remedied by performing operations in the linear domain instead. The process

may also be followed by additional color format conversion steps that aim at de-correlating color signals and isolating, commonly, intensity/brightness information from color.

- [70] FIG. 7 is an example dataflow diagram for converting R'G'B' to Y'CrCb. To perform such operations, Y' in the non-constant luminance case may be calculated as above i.e. $Y' = (M[1,1] * R' + M[1,2] * G' + M[1,3] * B')$. Then the Y_ncl, B, R, and G components (in the linear domain) may be calculated using the inverse transform function represented as ITF(). For example, in the Y_ncl can be optionally computed as $Y_ncl = ITF(Y')$, and the other components could be computed $B = ITF(B')$, $R = ITF(R')$, and $G = ITF(G')$. Then the downsampled version of each component may be calculated by applying a downsampling filter Down() to the linear components. Then the non-linear version of each downsampled component may be calculated using the transform function TF(x). Using the downsampled, non-linear version of the color components (B', R', and G'), the Y'CbCr components in the transfer domain may be calculated (as above). Alternatively, instead of the downsampled G' data embodiments can use the downsampled Y_ncl data to generate the Cb and Cr components (as above). It should be noted that that derivation would not be the same as using the downsampled G' data, since the downsampled Y_ncl is derived directly from Y', which involves the non-linearities of the transfer function. In this scenario, an appropriate decoder that also considers the downsampled Y_ncl is necessary in deriving the final signals.
- [71] According to an embodiment, the calculation of the G component may not be necessary. The Y' value calculated initially at the Y conversion block from the R', G', and B' components may be output as the Y' component.
- [72] According to an embodiment, the Y' component may not be available. For example, Y2' may not be generated directly from the downsampled RGB values. Then Cr and Cb may be generated from R2, B2, and G2.
- [73] Embodiments may determine that it is best to use a linear method for generating the downsampled version for one component, and a non-linear for the other. It is also possible to select that, for some instances, the non-linear method would be used for both or a combination of the two could be considered. This decision could be made adaptively or based on some predefined conditions. For example, this can be determined by evaluating for both cases the distortion introduced in each scenario, as in the adaptive filtering process, compared to the

original Cb and Cr components (without downsampling). An alternate color space could also be considered instead for this evaluation (e.g. RGB or XYZ), given an appropriate distortion measurement as discussed earlier. All possible or a subset of the combinations could be considered, e.g. consideration of non-linear downsampled Cb with linear downsampled Cr or/and vice versa, linear or non-linear downsampling for both components, etc. The decision process could be done for an entire image, region of an image, or even a single sample. Additional combinations could be generated by averaging the samples together from each conversion processes. Averaging could be a simple average or weighted average based on some characteristics of the signal, or based on distortion performance.

- [74] The process of downsampling in the linear domain or the adaptive technique, may be implemented in both the constant luminance and non-constant luminance domain, given the characteristics of each particular conversion, and may also be applied in alternative color spaces, such as $Y'u'v'$, $Y'u''v''$, IPT, ICtCp, or others. In those cases, for example, conversion to an intermediate color space may be required other than RGB. In particular, conversion to XYZ or other color spaces such as LMS, e.g. for the ICtCp and IPT cases, may first be required. Then, downsampling is performed in those spaces to generate the downsampled versions, and the appropriate downsampled signals that correspond to the color components are derived from these images.

Closed Loop Conversions

- [75] Conventionally, each color component of image data is quantized and converted independently of each other. For example, the Y' , Cb, and Cr components in the constant luminance or non-constant luminance domain, may be calculated and then each will be quantized by applying a quantizing function $Q()$. However, once the Y_q component is calculated, this value may be used to generate the Cb/Cr components. The same consideration could be made for other color spaces where there might be a dependency between the color components.
- [76] FIG. 8 is an example dataflow diagram for converting $R'G'B'$ to YCbCr. In this example, in the non-constant luminance domain, upon receiving the RGB input, Y' may be calculated (in the transfer domain) as above ($Y' = M[1,1] * R' + M[1,2] * G' + M[1,3] * B'$). Then the quantized value of Y' may be calculated and using the quantized value, Y_r' may be reconstructed. Then, using the reconstructed value of Y_r' , Cb' and Cr' may be calculated as described above ($Cb' =$

$(B' - Yr') * Sb$ and $Cr' = (R' - Yr') * Sr$). The quantized values of Cb/Cr may then be calculated using a quantization function. The downsampling process, in the case of converting the data to 4:2:2 or 4:2:0, and the distortion this introduces, may also be considered in this step, as discussed in previous sections.

- [77] Similarly, in the constant luminance domain, Y in the linear domain is first calculated as $Y = M[1,1] * R + M[1,2] * G + M[1,3] * B$ and then Y' in the transfer domain is calculated as $Y' = TF(Y)$. Then the quantized value of Y' , Cr' , and Cb' may be calculated as described above for the non-constant luminance case.
- [78] The decoder or receiver may inverse these processes as necessary to generate recovered color components.
- [79] As shown in FIG. 8, the Y component may additionally be encoded and decoded to account for compression loss when calculating the Cb/Cr components.
- [80] According to an embodiment, any error introduced in previously quantized and processed color component can be fed into later quantized and processed color components. By changing the order of the component calculation to compute different components first and then use that information to calculate the other components, the 1) quantization error, 2) compression error, and/or 3) chroma subsampling error of any one component may be considered in the creation of the remaining components.
- [81] For example, Cb may be calculated as $Sb * M[1,1] * R - Sb * M[1,2] * G + (Sb - Sb * M[1,3]) * B$. Then Y is calculated as $Y = B - Cb/Sb$ and Cr is calculated as $Cr = (Sr - Sr * M[1,1]) * R - Sr * M[1,2] * G - Sr * M[1,3] * B$. Similarly, Cr may be calculated first, then Y , and then Cb , or Cr may be calculated first, then Cb , and then Y , etc.
- [82] The above steps could be applied on other color spaces and not only $Y'CbCr$ data. Other spaces may include, for example, the $Y'u'v'$, $Y'u''v''$, IPT, and ICtCp color spaces among others. Intermediate conversion to other color spaces, such as XYZ or LMS may be required for this conversion. These steps could be combined with all other methods discussed in all other sections of this disclosure.

Extensions

- [83] In this section, extensions to the closed loop color conversion methods described above are presented. As discussed, improved chroma conversion, e.g. from 4:4:4 RGB to 4:2:0 Y'CbCr, could be achieved by accounting for the distortion introduced during the conversion process. In particular, when converting RGB data to Y'CbCr a codec or preprocessor may estimate the impact of quantization on luma (Y') when converting the Cb and Cr components, or estimate the impact of quantization and potentially of downsampling and upsampling to the Cb and Cr components to convert the Y' component using simple formulations.
- [84] In this extension, a refinement of that approach may be employed that improves performance over the original discussion. Furthermore, these refinements may find application in other conversion techniques that employ “micrograding” approaches by improving optimization bounds of those techniques, which speeds convergence. Alternatives that improve not just the luminance information, but additional or other information such as color, are also discussed.
- [85] As discussed above, derivation of chroma and or luma information can be performed using already-processed luma and/or chroma information respectively. In this extension, the derivation of luma information given conversion of co-located chroma data and the processing applied on that data is presented. Commonly, color conversion from R'G'B' data to Y'CbCr is performed using a 3x3 matrix conversion of the form:

$$\begin{bmatrix} Y' \\ Cb \\ Cr \end{bmatrix} = \begin{bmatrix} a_{YR} & a_{YG} & a_{YB} \\ a_{CbR} & a_{CbG} & a_{CbB} \\ a_{CrR} & a_{CrG} & a_{CrB} \end{bmatrix} \begin{bmatrix} R' \\ G' \\ B' \end{bmatrix}$$

- [86] However, Cb and Cr are also related to Y' in the following manner:

$$Cb = \frac{B' - Y'}{\alpha} \text{ with } \alpha = 2 * (1 - a_{YB})$$

$$Cr = \frac{R' - Y'}{\beta} \text{ with } \beta = 2 * (1 - a_{YR})$$

with also the following relationships:

$$a_{CbR} = -\frac{a_{YR}}{2*(1-a_{YB})}$$

$$a_{CbG} = -\frac{a_{YG}}{2*(1-a_{YB})}$$

$$a_{CbB} = 0.5$$

$$a_{CrR} = 0.5$$

$$a_{CrG} = -\frac{a_{YG}}{2*(1-a_{YR})}$$

$$a_{CrB} = -\frac{a_{YB}}{2*(1-a_{YR})}$$

- [87] Given these formulations, as discussed above, instead of performing the conversion as a single 3x3 matrix conversion process, prior embodiments use a two-step approach, where the Cb and Cr values first are generated from source image content and, then, the Y' component is generated from an estimate of distortion introduced in the Cb and Cr quantities through quantization and, if used, downsampling and upsampling. More specifically, consider Cb and Cr conversion that is performed as:

$$Cb = a_{CbR}R' + a_{CbG}G' + a_{CbB}B'$$

$$Cr = a_{CrR}R' + a_{CrG}G' + a_{CrB}B'$$

followed by quantization and downscaling (QD) and subsequently upscaling and inverse quantization (IQD) (these steps could be performed in any order) as:

$$Cb^* = \text{IQU}(\text{QD}(Cb))$$

$$Cr^* = \text{IQU}(\text{QD}(Cr)).$$

Then, given the formulations of luma and chroma, luma could be computed as:

$$Y'_{Cb} = B' - Cb^* * 2 * (1 - a_{YB}) = B' - Cbfactor$$

$$Y'_{Cr} = R' - Cr^* * 2 * (1 - a_{YR}) = R' - Crfactor$$

These computed Y'_{Cb} and Y'_{Cr} values can be used in various ways to determine a final Y' value to be used along with Cr and Cb . In some embodiments, a final selected Y' value may be a weighted linear combination of Y'_{Cb} and Y'_{Cr} . Such a final solution may be computed as:

$$Y'_{final} = w * Y'_{Cb} + (1 - w) * Y'_{Cr}$$

where w is a weighting parameter. Combining also with the directly computed Y' given the original matrix conversion with an appropriate weight is also possible.

[88] The above formulation, although straightforward, has the drawback that it ignores the different errors that may have been introduced during the conversion processes of Cb and Cr . Accordingly, a first embodiment may account for that distortion when selecting the value of Y'_{final} . In particular, the above computation is extended as follows.

[89] Apart from computing Y'_{Cb} and Y'_{Cr} , which essentially captures the impact on Y' given the errors in Cb and Cr and the original Red and Blue components of the source image data, a color converter also may compute the value of Y'_G that essentially captures the impact from the Green component of the source image data as well. Close inspection of the conversion process shows us that Y'_G can be computed as:

$$Y'_G = G' + \frac{Cb^* * 2 * a_{YB} * (1 - a_{YB}) + Cr^* * 2 * a_{YR} * (1 - a_{YR})}{a_{YG}} = G' + Gfactor$$

[90] Now, given the three values of Y' , i.e. Y'_{Cb} , Y'_{Cr} , and Y'_G , as well as the values of Cb^* and Cr^* , embodiments may then compute for each case the resulting values for R' , G' , and B' . Embodiments may then base the decision by selecting the value that results in the least overall distortion among these three. More specifically, embodiments may compute the R' , G' , and B' components, given a particular Y' value and the already computed $Cbfactor$, $Crfactor$, and $Gfactor$ quantities, as:

$$B'_{rec} = Y' + Cbfactor$$

$$R'_{rec} = Y' + Crfactor$$

$$G'_{rec} = Y' - Gfactor$$

and the introduced distortion as:

$$D(Y') = w_R * D(R', R'_{rec}) + w_G * D(G', G'_{rec}) + w_B * D(B', B'_{rec})$$

where w_R , w_G , and w_B are weighting factors that can control the importance of a particular component versus the other components, and D is a distortion function, such as absolute difference, square error, etc. The value of Y' that results in the least distortion as formulated above can be selected as the final Y' for the signal. The values of w_R , w_G , and w_B can be fixed, e.g. all equal, or can be based on psycho-visual models, such as the [1, 2, 1] model commonly employed by most cameras, or could be adaptive per region or per sample and could be derived based on an analysis of the spatial and even temporal characteristics of the signal. Information about the viewing target, e.g. the characteristics of the target display and the viewing environment/ambient lighting, could also be considered to derive these weighting factors. A different formulation for this distortion, where even the distortion for each color component is computed using a different method, can also be considered.

- [91] In a refinement of this method, embodiments can compute the minimum and maximum Y' values from the Y' value options computed above, e.g. $Y'_{min} = \min(Y'_{Cb}, Y'_{Cr}, Y'_G)$ and $Y'_{max} = \max(Y'_{Cb}, Y'_{Cr}, Y'_G)$ and then perform a search across all values from Y'_{min} to Y'_{max} to find the value that results in a minimum D . That is, the pseudocode for such a search would be as follows:

$$Y'_{min} = \min(Y'_{Cb}, Y'_{Cr}, Y'_G)$$

$$Y'_{max} = \max(Y'_{Cb}, Y'_{Cr}, Y'_G)$$

$$bestY = Y'_{min}$$

$$bestD = \text{computedD}(\text{currY})$$

$$\text{for } (\text{currY} = Y'_{min} + 1; \text{currY} \leq Y'_{max}; \text{currY}'_{min} += \text{stepY}) \{$$

```

currD= computeD(currY)
if (currD<bestD) {
    bestD=currD
    bestY=currY
}
}

```

where computeD computes the distortion as specified above, stepY is the step size of the search (commonly stepY=1, but other, larger values could be used to accelerate the search). The above pseudocode allows us to determine basically the optimal Y' value given the specified distortion criterion D. It is obvious that if all values are the same, then no search will be performed and the optimal point would be found after a single step. Speed ups to the above could also be performed, e.g. by assuming that the distortion follows a monotonic behavior around the minimum point or by performing other fast type searches such as using a bisection, Newton Raphson, Secant, Brent, Broyden or other search among others, performing a hierarchical search and first starting with a larger value for stepY (first hierarchy), then refining the search with smaller step sizes (subsequent hierarchies) when the optimal/best value for a hierarchy has been reached. A suboptimal search would be to find the points among Y'_{Cb} , Y'_{Cr} , and Y'_G that result in the two lowest distortion values for D and only search in the area between them, however that might not always result in the optimal point.

[92] FIG. 9 illustrates a method 900 according to an embodiment of the present disclosure. The method 900 may begin by estimating Y' values from different sources – Cb, Cr and G – yielding three different estimates of Y' (box 910). The method 900 may define a range of Y' from the minimum and maximum values obtained from the estimates (box 920). The method 900 then may perform an iterative search along the range of Y' values for a value that minimizes distortion. For example, at each iteration, the method 900 may result in a distortion value that would arise from use of a Y' value of the current iteration (curr_Y) (box 930). The method may determine whether the estimated distortion is lower than distortions estimated in prior iterations (box 940) and, if so, the method 900 may select the Y' value of the current iteration as the best Y' value (best_Y) to use (box 950). The method 900 may repeat this process through each iteration until the end of the range is encountered (box 960). At the end of the search, the

method 900 may identify the Y' value within the range Y'_{\min} to Y'_{\max} that generates the least amount of distortion.

- [93] The present embodiment accommodates additional processing to speed up the search. For example, in circumstances where distortion is expected to increase or decrease monotonically across the range, the method 900 may determine whether the distortion estimate of a current iteration is larger than the distortion estimate of a prior iteration. If so, the method 900 may terminate the search and use the best Y value that was identified to that point in the method 900.
- [94] The principles of the present disclosure may find application in other schemes to estimate Y' values. For example, the computation of Y'_{Cb} , Y'_{Cr} , and Y'_G can speed up the optimization process to derive Y' according to a micrograding approach. In micrograding approaches, the value of Y' (luma) was derived in a manner that would result in the best possible value of Y (luminance) for the signal. From the earlier formulations, embodiments may basically compute that:

$$Y = a_{YR}R + a_{YG}G + a_{YB}B \Rightarrow$$

$$Y = a_{YR} * iTF(Y' + Crfactor) + a_{YG} * iTF(Y' - Gfactor) + a_{YB} * iTF(Y' + Cbfactor)$$

where iTF is the inverse of the transfer function that was applied on the R , G , and B data to generate the luma information. Unfortunately, due to the non-linearity of this transfer function, solving for Y' given Y and the values of $Crfactor$, $Gfactor$, and $Cbfactor$ is difficult. A bisection method has been proposed, although such proposals required elaborate computation because the proposal did not compute the values of $Crfactor$, $Gfactor$, and $Cbfactor$, resulting in some unnecessary computations in implementation.

- [95] An issue with the bisection method is that it can take some time to find the optimal solution. Prior proposals tried to improve convergence and to find the optimal solution by determining bounds of Y' based on the relationship of luminance (Y), the color conversion used for the constant luminance conversion, and the transfer function used. More specifically, the limits that were derived involved computing first the transfer function converted luminance information, i.e. $TF(Y)$, the resulting R' , B' , and G' values if that value of $Y'=TF(Y)$ was used, the minimum among these three, i.e. $\min(R', B', G')$, as well as the upper bound of the quantized value of $TF(Y)$. The value of $\min(R', B', G')$ was used as the lower bound for the optimization

(minYpBound), whereas the quantized value of $TF(Y)$ was used as the upper bound (maxYpBound). That can help in speeding up the search for the minimum somewhat.

- [96] However, much better low and upper bounds could be determined by, instead, considering the values of Y'_{Cb} , Y'_{Cr} , and Y'_G , computation that was presented above. In particular, after computing minYpBound and maxYpBound as discussed above or alternatively from computing the bounds in that manner, the present embodiment limits the bounds based on the $Y'_{min} = \min(Y'_{Cb}, Y'_{Cr}, Y'_G)$ and $Y'_{max} = \max(Y'_{Cb}, Y'_{Cr}, Y'_G)$ described above. That is, an embodiment may set $\text{minYpBound} = \max(\text{minYpBound}, Y'_{min})$ and set $\text{maxYpBound} = \min(\text{maxYpBound}, Y'_{max})$. The use of these bounds in a micrograding process can result in substantial computational savings compared to the original proposal, i.e. basically a faster computation of the optimal Y' value. The consideration also of the computation given the Crfactor, Gfactor, and Cbfactor, instead of the full computation of RGB given the inversion of the 3x3 matrix from RGB to $Y'CbCr$, that is being used in the original proposal can also provide additional speedups (although it should be noted that this can be seen as more of an implementation optimization instead of an algorithmic optimization, unlike the improved bounds computation method). The proposed method could be combined with other numerical analysis methods that are used for finding roots of a function, such as the Newton, Secant, Brent, and Broyden methods among others.
- [97] FIG. 10 illustrates a method 1000 according to an embodiment of the present disclosure. The method 1000 may begin by setting a target value of linear luminance (L_{target}) from the content of the source image (box 1010). The method 1000 also may estimate Y' values from Cb, Cr, and G values as discussed above (box 1015). The method 1000 further may set Y'_{max} and Y'_{min} values from the Y' estimates obtained in box 1020 (box 1020).
- [98] Following these operations, the method 1000 may derive a Y' value (Y'_{final}) according to a micrograding search process. As illustrated in FIG. 10, the method may determine whether Y'_{max} is greater than $Y'_{min}+1$ (box 1025). If so, the method 1000 may develop a curr_ Y' value as an average of Y'_{max} and Y'_{min} (box 1030) and compute a linear luminance value L_{res} from the curr_ Y' value and the Cb, Cr values (box 1035). The method 1000 may determine whether L_{res} is less than the L_{target} value (box 1040). If so, the method 1000 may reset the Y'_{min} value to the curr_ Y' value (box 1045). If not, the method 1000 may reset the Y'_{max} value to the curr_ Y' value

(box 1050). The method 1000 may return to box 1025 for another iteration of processing following the operations represented by boxes 1045 and 1050.

- [99] If, at box 1025, the method determines that Y'_{\max} is not greater than $Y'_{\min}+1$, the method 1000 may determine whether Y'_{\max} is equal to Y'_{\min} . If so, the method 1000 may conclude, setting the derived Y' value, Y'_{final} , as Y'_{\max} (box 1060).
- [100] If not, however, the method 1000 may derive linear luminance values L_{resmax} and L_{resmin} from the Y'_{\max} , Y'_{\min} , C_b and C_r values (box 1065). Specifically, the L_{resmax} value may be derived by converting the values of Y'_{\max} , C_b , and C_r , from the YCbCr space to another space, such as XYZ (with $L = Y$), and the L_{resmin} value may be derived by a similar conversion of the values represented by Y'_{\min} , C_b , and C_r value. The method 1000 may estimate amounts of distortion D_{max} , D_{min} associated respectively with the L_{resmax} and L_{resmin} values based on a comparison between the L_{resmax} and L_{resmin} values and the target value L_{target} according to a distortion function D (box 1070). The method may determine whether the estimated D_{min} distortion is less than the estimated D_{max} distortion (box 1075). If so, the method 1000 may advance to box 1060, setting the derived Y' value, Y'_{final} , as Y'_{\max} and the method 1000 may conclude. If not, the method 1000 may conclude, setting the derived Y' value, Y'_{final} , as Y'_{\min} (box 1080).
- [101] Although FIG. 10 illustrates the range being set solely from $Y'_{\min} = \min(Y'_{Cb}, Y'_{Cr}, Y'_G)$ and $Y'_{\max} = \max(Y'_{Cb}, Y'_{Cr}, Y'_G)$ in box 1020, as discussed, another embodiment may set $\text{minYPBound} = \max(\text{minYPBound}, Y'_{\min})$ and $\text{maxYPBound} = \min(\text{maxYPBound}, Y'_{\max})$. In another embodiment these could be set as $f_1(\text{minYPBound}, Y'_{\min})$ and $f_2(\text{maxYPBound}, Y'_{\max})$ where $f_1()$ and $f_2()$ are other functions such as averaging or weighted averaging, which may result in less bounded limits. This may be helpful if the behavior of the process is not monotonic.
- [102] The improved bounds computation method provides the ability to also extend the method in a less complex manner and to compute the best Y' not only given the distortion for L/Y (luminance) but also given the distortion for other components, such as X and Z (given CIE 1931) or R , G , and B . The bounds can still specify the range of values that embodiments may perform a search on and essentially compute the joint distortion of not only Y , but also X and Z , or alternatively or additionally R , G , and B (in the linear domain instead of the non-linear domain that was described earlier). Other features, such as saturation S and hue H , or color

values u' and v' based on CIE 1976, could also be considered instead or in addition to the other sample features, during the optimization process, i.e. by computing and accounting for their distortion. For example, embodiments may now have a distortion function for the optimization process that may look as follows:

[103] For example, in the XYZ color space, distortion may be estimated according to a process as:

$$D(Y') = w_X * D(X', X'_{rec}) + w_Y * D(Y', Y'_{rec}) + w_Z * D(Z', Z'_{rec})$$

or, when operating on saturation S and hue H values, distortion may be estimated as:

$$D(Y') = w_S * D_S(S, S_{rec}) + w_H * D_H(H, H_{rec}).$$

[104] Moreover, distortion estimates may consider distortion effects in multiple color spaces simultaneously, such as by:

$$D_{overall}(Y') = w_R * D_R(R', R'_{rec}) + w_G * D_G(G', G'_{rec}) + w_B * D_B(B', B'_{rec}) + w_Y * D_Y(Y, Y_{rec}) \\ + w_X * D_X(X, X_{rec}) + w_Z * D_Z(Z, Z_{rec}) + w_S * D_S(S, S_{rec}) + w_H * D_H(H, H_{rec})$$

Such distortion estimates find application, for example, in the method of FIG. 9.

[105] Note that this disclosure uses a different notation for the distortion of each color component since it may be desirable to compute distortion for each component in a different domain or with a different formulation. For example, distortion for Y (luminance) may be computed after the application of a corresponding transfer function (i.e. allowing better consideration of the psychovisual impact of a particular value), using absolute difference versus square error etc. Some values may also be combined and considered jointly, e.g. by computing the square root of the distortion values from R, G, and B prior to combining them with Y. It should be understood that the above formulation is not the only possible way to consider the joint impact on distortion among all these values, and other formulations can be used instead.

General Considerations

[106] Each of the processes described above may be applied in alternative color spaces including YUV, $Y'u'v'$, XYZ, $Y'dzdx$, $Y'u''v''$, IPT, ICtCp, LAB, etc.

- [107] According to an embodiment, the encoder may transmit information with the coded video data in logical channels established by the governing protocol for out-of-band data. Such information may include filter selection, quantization parameters, and other hint information. As one example, used by the AVC/H.264 and HEVC/H.265 video coding standards/protocols, the encoder 200 may transmit accumulated statistics in a supplemental enhancement information (SEI) channel specified by AVC or HEVC. In such an embodiment, processes introduce the information in a logical channel corresponding to the SEI channel. When the present invention is to be used with protocols that do not specify such out-of-band channels, a separate logical channel for the noise parameters may be established within the output channel.
- [108] Although the foregoing description includes several exemplary embodiments, it is understood that the words that have been used are words of description and illustration, rather than words of limitation. Changes may be made within the purview of the appended claims, as presently stated and as amended, without departing from the scope and spirit of the disclosure in its aspects. Although the disclosure has been described with reference to particular means, materials and embodiments, the disclosure is not intended to be limited to the particulars disclosed; rather the disclosure extends to all functionally equivalent structures, methods, and uses such as are within the scope of the appended claims. For example, embodiments of the present invention may provide a method of coding; a non-transitory computer readable medium storing program instructions that, when executed by a processing device, causes the device to perform one or more of the methods described herein; a video coder, etc.
- [109] As used herein, the term “computer-readable medium” may include a single medium or multiple media, such as a centralized or distributed database, and/or associated caches and servers that store one or more sets of instructions. The term shall also include any medium that is capable of storing, encoding or carrying a set of instructions for execution by a processor or that cause a computer system to perform any one or more of the embodiments disclosed herein.
- [110] The computer-readable medium may comprise a non-transitory computer-readable medium or media and/or comprise a transitory computer-readable medium or media. In a particular non-limiting, exemplary embodiment, the computer-readable medium may include a solid-state memory such as a memory card or other package that houses one or more non-volatile read-only memories. Further, the computer-readable medium may be a random access memory or other

volatile re-writable memory. Additionally, the computer-readable medium may include a magneto-optical or optical medium, such as a disk or tapes or other storage device to capture carrier wave signals such as a signal communicated over a transmission medium. Accordingly, the disclosure is considered to include any computer-readable medium or other equivalents and successor media, in which data or instructions may be stored.

- [111] The present specification describes components and functions that may be implemented in particular embodiments which may operate in accordance with one or more particular standards and protocols. However, the disclosure is not limited to such standards and protocols. Such standards periodically may be superseded by faster or more efficient equivalents having essentially the same functions. Accordingly, replacement standards and protocols having the same or similar functions are considered equivalents thereof.
- [112] The illustrations of the embodiments described herein are intended to provide a general understanding of the various embodiments. The illustrations are not intended to serve as a complete description of all of the elements and features of apparatus and systems that utilize the structures or methods described herein. Many other embodiments may be apparent to those of skill in the art upon reviewing the disclosure. Other embodiments may be utilized and derived from the disclosure, such that structural and logical substitutions and changes may be made without departing from the scope of the disclosure. Additionally, the illustrations are merely representational and may not be drawn to scale. Certain proportions within the illustrations may be exaggerated, while other proportions may be minimized. Accordingly, the disclosure and the figures are to be regarded as illustrative rather than restrictive.
- [113] For example, operation of the disclosed embodiments has been described in the context of servers and terminals that implement encoding optimization in video coding applications. These systems can be embodied in electronic devices or integrated circuits, such as application specific integrated circuits, field programmable gate arrays and/or digital signal processors. Alternatively, they can be embodied in computer programs that execute on personal computers, notebook computers, tablets, smartphones or computer servers. Such computer programs typically are stored in physical storage media such as electronic-, magnetic- and/or optically-based storage devices, where they may be read to a processor, under control of an operating system and executed. And, of course, these components may be provided as hybrid systems that distribute

functionality across dedicated hardware components and programmed general-purpose processors, as desired.

- [114]** In addition, in the foregoing description, various features may be grouped or described together the purpose of streamlining the disclosure. This disclosure is not to be interpreted as reflecting an intention that all such features are required to provide an operable embodiment, nor that the claimed embodiments require more features than are expressly recited in each claim. Rather, as the following claims reflect, subject matter may be directed to less than all of the features of any of the disclosed embodiments. Thus, the following claims are incorporated into the description, with each claim standing on its own as defining separately claimed subject matter.
- [115]** Also, where certain claims recite methods, sequence of recitation of a particular method in a claim does not require that that sequence is essential to an operable claim. Rather, particular method elements or steps could be executed in different orders without departing from the scope or spirit of the invention.

WE CLAIM:

1. An image conversion method, comprising:
 - determining values for Cb and Cr for image data according to a transform from the image data's source color space to a Y'CrCb color space;
 - producing a reconstructed Cb* value and a reconstructed Cr* value by processing the Cb and Cr values according to a lossy process, then inverting the lossy process;
 - deriving a Y' value from the image data and the Cb* and Cr* values; and
 - outputting the derived Y' value, Cb value, and Cr value as converted image data.
2. The method of claim 1, wherein the source color space is R'G'B' and the deriving comprises:
 - determining a first Y' value (Y'_{Cb}) from B' and Cb*;
 - determining a second Y' value (Y'_{Cr}) from R' and Cr*;
 - determining a third Y' value (Y'_G) from Cb*, Cr* and G', and
 - the deriving includes blending the Y'_{Cb} , Y'_{Cr} and Y'_G values.
3. The method of claim 1, wherein the source color space is R'G'B' and the deriving comprises:
 - determining a first Y' value (Y'_{Cb}) from B' and Cb*;
 - determining a second Y' value (Y'_{Cr}) from R' and Cr*;
 - determining a third Y' value (Y'_G) from Cb*, Cr* and G';
 - calculating distortion metrics corresponding to the first, second, and third Y' values, where the distortion metric is based on the Cb* and Cr* values and the corresponding Y' value; and
 - the deriving includes selecting the Y' from amongst the first, second, and third Y' values with the lowest corresponding distortion.
4. The method of claim 1, further comprising:
 - determining a minimum Y' value option and a maximum Y' value option based on Cb* and Cr*;
 - searching for a minimum of a distortion metric over Y' values that range from the minimum Y' value option to the maximum Y' value option; and

the deriving includes selecting the Y' value corresponding to the minimum of the distortion metric.

5. The method of claim 1, wherein:

the source color space is $R'G'B'$,

the deriving is based on a distortion metric for candidate Y' values; and

the distortion metric for a candidate Y' value is calculated as a weighted linear combination of distortions values for R' , G' , and B' where:

the distortion value for R' is based on Cr and the candidate Y' value;

the distortion value for B' is based on Cb and the candidate Y' value; and

the distortion value for G' is based on G and the candidate Y' value.

6. The method of claim 1, wherein the reconstructed Cb^* and Cr^* values are produced by one or more of the following:

quantizing and then inverse quantizing the Cb and Cr values;

downscaling and then upscaling the Cb and Cr values; and

encoding and then decoding the Cb and Cr values.

7. The method of claim 1, wherein the deriving includes a micrograding process.

8. A non-transitory computer readable medium comprising instructions for color space conversion, the medium comprising instructions that, when executed on a computer, cause at least:

determining values for Cb and Cr for image data according to a transform from the image data's source color space to a $Y'CrCb$ color space;

producing a reconstructed Cb^* value and a reconstructed Cr^* value by processing the Cb and Cr values according to a lossy process, then inverting the lossy process;

deriving a Y' value from the image data and the Cb^* and Cr^* values; and

outputting the derived Y' value, Cb value, and Cr value as converted image data.

9. The non-transitory computer readable medium of claim 8, wherein the source color space is $R'G'B'$ and wherein the instructions for deriving a Y' value include instructions to cause:

determining a first Y' value (Y'_{Cb}) from B' and Cb^* ;

determining a second Y' value (Y'_{Cr}) from R' and Cr*;
determining a third Y' value (Y'_G) from Cb*, Cr* and G', and
blending the Y'_{Cb} , Y'_{Cr} and Y'_G values.

10. The non-transitory computer readable medium of claim 8, wherein the source color space is R'G'B' and wherein the instructions for deriving a Y' value include instructions to cause:

determining a first Y' value (Y'_{Cb}) from B' and Cb*;
determining a second Y' value (Y'_{Cr}) from R' and Cr*;
determining a third Y' value (Y'_G) from Cb*, Cr* and G', and

calculating distortion metrics corresponding to the first, second, and third Y' values, where the distortion metric is based on the Cb* and Cr* values and the corresponding Y' value; and

selecting the Y' from amongst the first, second, and third Y' values with the lowest corresponding distortion.

11. The non-transitory computer readable medium of claim 8, wherein the instructions further cause:

determining a minimum Y' value option and a maximum Y' value option based on Cb* and Cr*;

searching for a minimum of a distortion metric over Y' values that range from the minimum Y' value option to the maximum Y' value option; and

the deriving includes selecting the Y' value corresponding to the minimum of the distortion metric.

12. The non-transitory computer readable medium of claim 8, wherein the instructions further cause:

the source color space is R'G'B',

the deriving is based on a distortion metric for candidate Y' values; and

the distortion metric for a candidate Y' value is calculated as a weighted linear combination of distortions values for R', G', and B' where:

the distortion value for R' is based on Cr and the candidate Y' value;

the distortion value for B' is based on Cb and the candidate Y' value; and

the distortion value for G' is based on G and the candidate Y' value.

13. The non-transitory computer readable medium of claim 8, wherein the instructions further cause:

quantizing and then inverse quantizing the C_b and C_r values;
downscaling and then upscaling the C_b and C_r values; and
encoding and then decoding the C_b and C_r values.

14. The non-transitory computer readable medium of claim 8, wherein the deriving includes a micrograding process.

15. A system comprising at least a processor and a memory storing instructions thereon that, when executed by the system, cause at least:

determining values for C_b and C_r for image data according to a transform from the image data's source color space to a $Y'CrCb$ color space;

producing a reconstructed C_b^* value and a reconstructed C_r^* value by processing the C_b and C_r values according to a lossy process, then inverting the lossy process;

deriving a Y' value from the image data and the C_b^* and C_r^* values; and

outputting the derived Y' value, C_b value, and C_r value as converted image data.

16. The system of claim 15, wherein the instructions for the determining includes instructions that cause:

determining a first Y' value (Y'_{Cb}) from B' and C_b^* ;

determining a second Y' value (Y'_{Cr}) from R' and C_r^* ;

determining a third Y' value (Y'_G) from C_b^* , C_r^* and G' , and

the deriving includes blending the Y'_{Cb} , Y'_{Cr} and Y'_G values.

17. The system of claim 15, wherein the wherein the instructions for the determining includes instructions that cause:

determining a first Y' value (Y'_{Cb}) from B' and C_b^* ;

determining a second Y' value (Y'_{Cr}) from R' and C_r^* ;

determining a third Y' value (Y'_G) from C_b^* , C_r^* and G' ;

calculating distortion metrics corresponding to the first, second, and third Y' values, where the distortion metric is based on the Cb^* and Cr^* values and the corresponding Y' value; and

the deriving includes selecting the Y' from amongst the first, second, and third Y' values with the lowest corresponding distortion.

18. The system of claim 15, wherein the instructions further cause:

determining a minimum Y' value option and a maximum Y' value option based on Cb^* and Cr^* ;

searching for a minimum of a distortion metric over Y' values that range from the minimum Y' value option to the maximum Y' value option; and

the deriving includes selecting the Y' value corresponding to the minimum of the distortion metric.

19. The system of claim 15, wherein

the source color space is $R'G'B'$,

the deriving is based on a distortion metric for candidate Y' values; and

the distortion metric for a candidate Y' value is calculated as a weighted linear combination of distortions values for R' , G' , and B' where:

the distortion value for R' is based on Cr and the candidate Y' value;

the distortion value for B' is based on Cb and the candidate Y' value; and

the distortion value for G' is based on G and the candidate Y' value.

20. The system of claim 15, wherein the instructions further cause:

quantizing and then inverse quantizing the Cb and Cr values;

downscaling and then upscaling the Cb and Cr values; and

encoding and then decoding the Cb and Cr values.

21. The method of claim 3, wherein the distortion is computed as the square error difference between the original luminance Y value and the reconstructed luminance value for each Y' , Cb^* , and Cr^* combination.

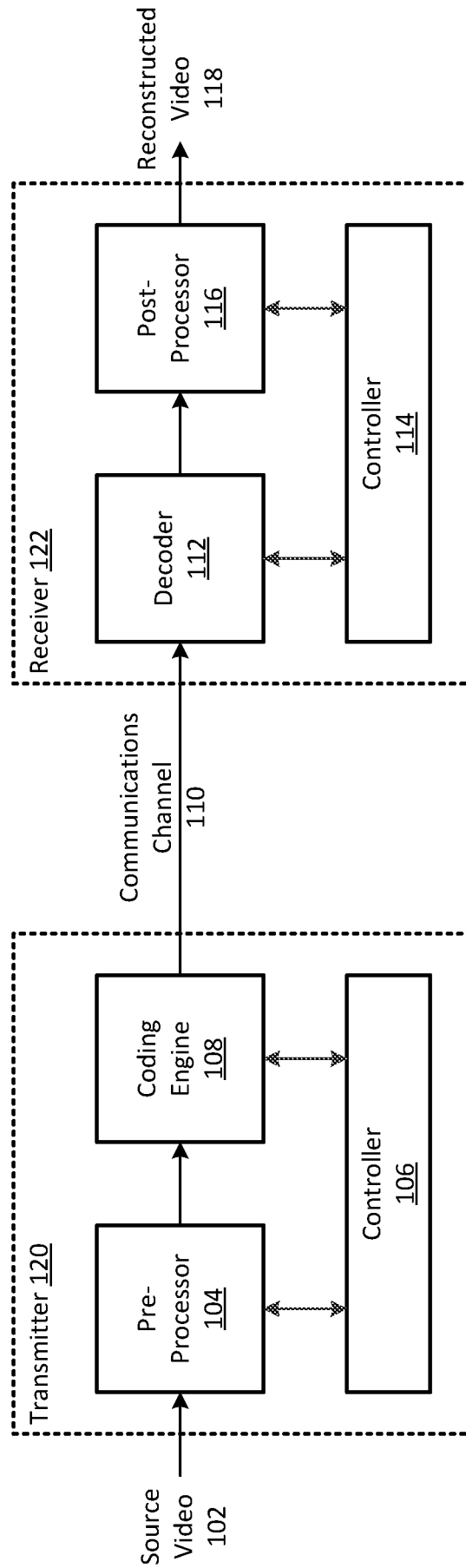

FIG. 1

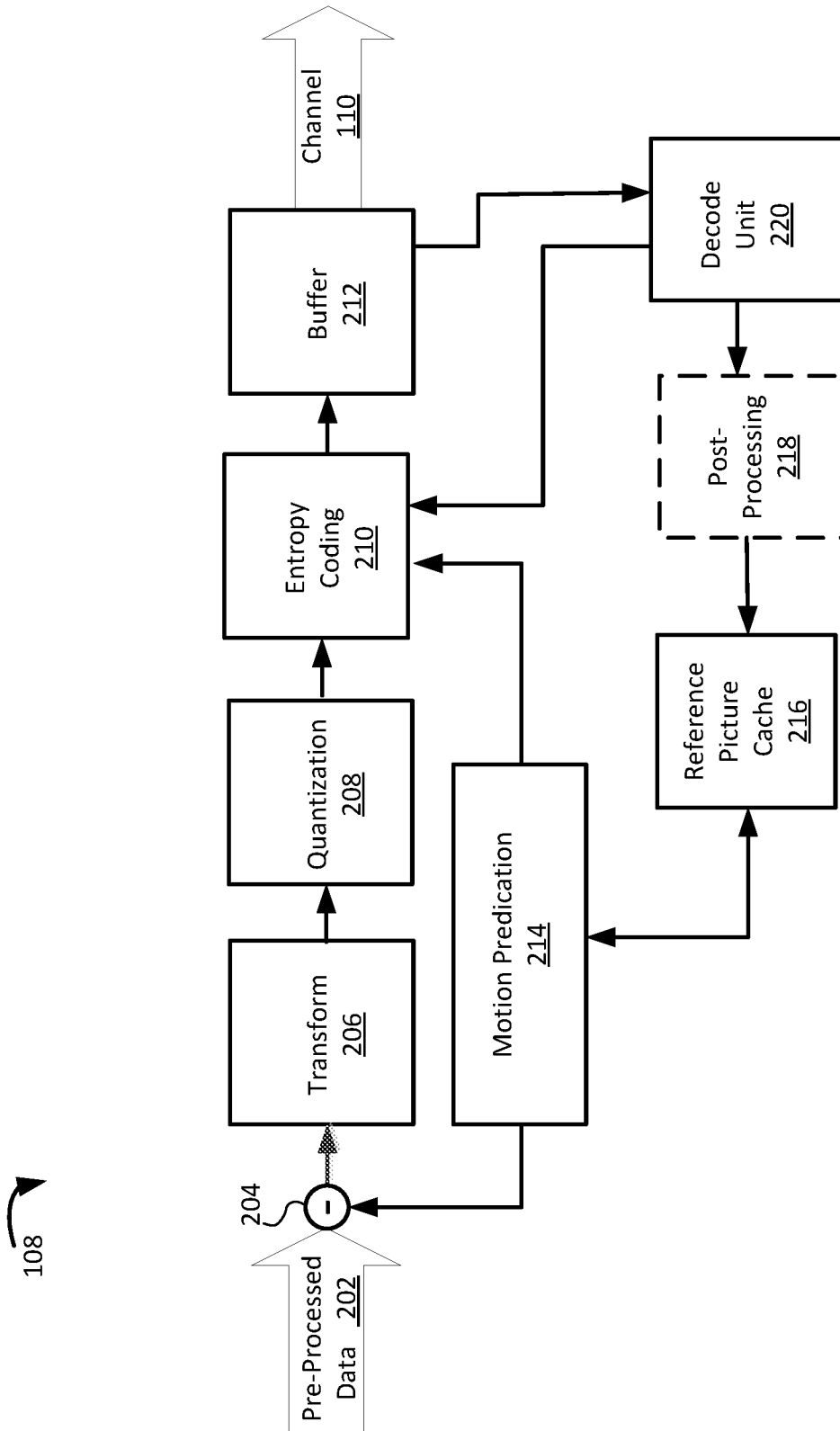

FIG. 2

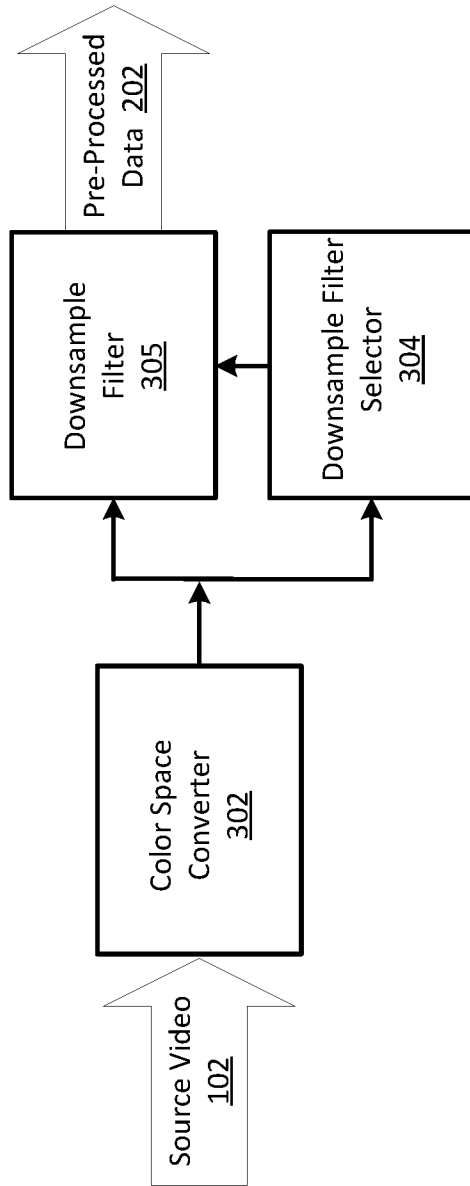

FIG. 3

4/10

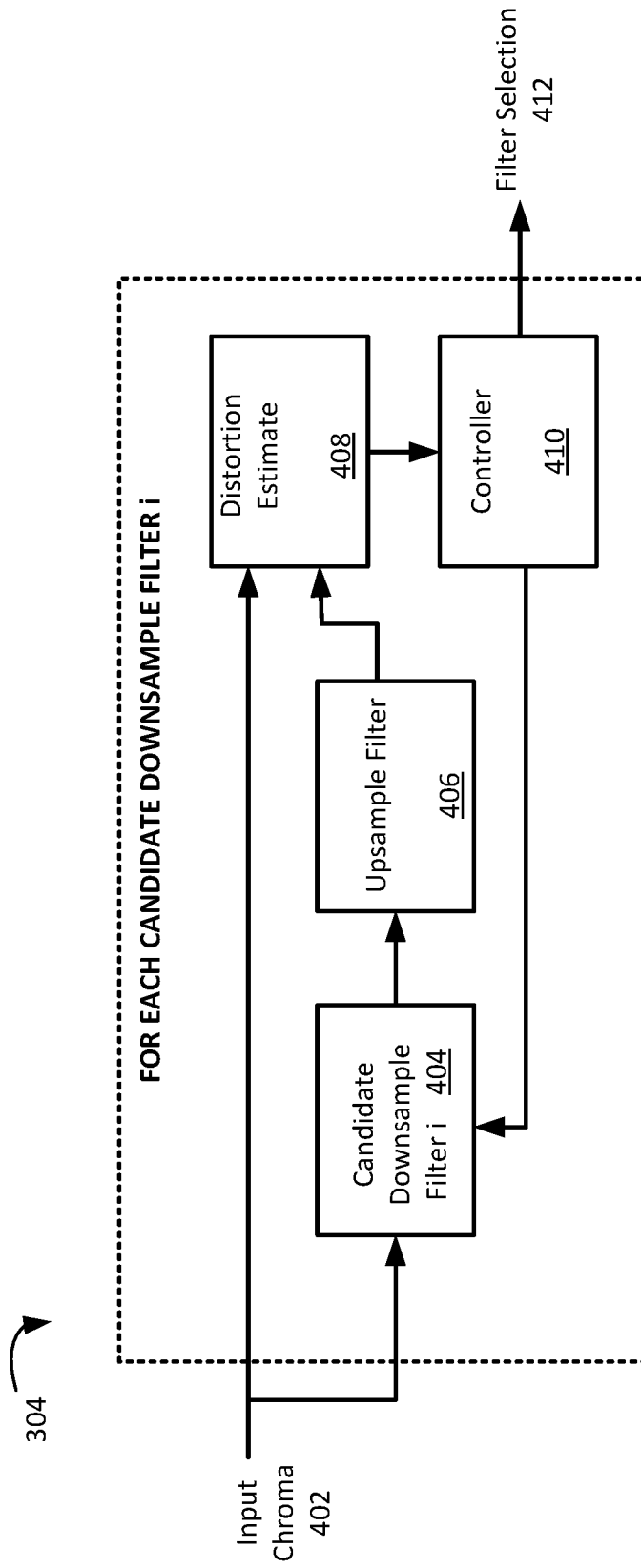

FIG. 4

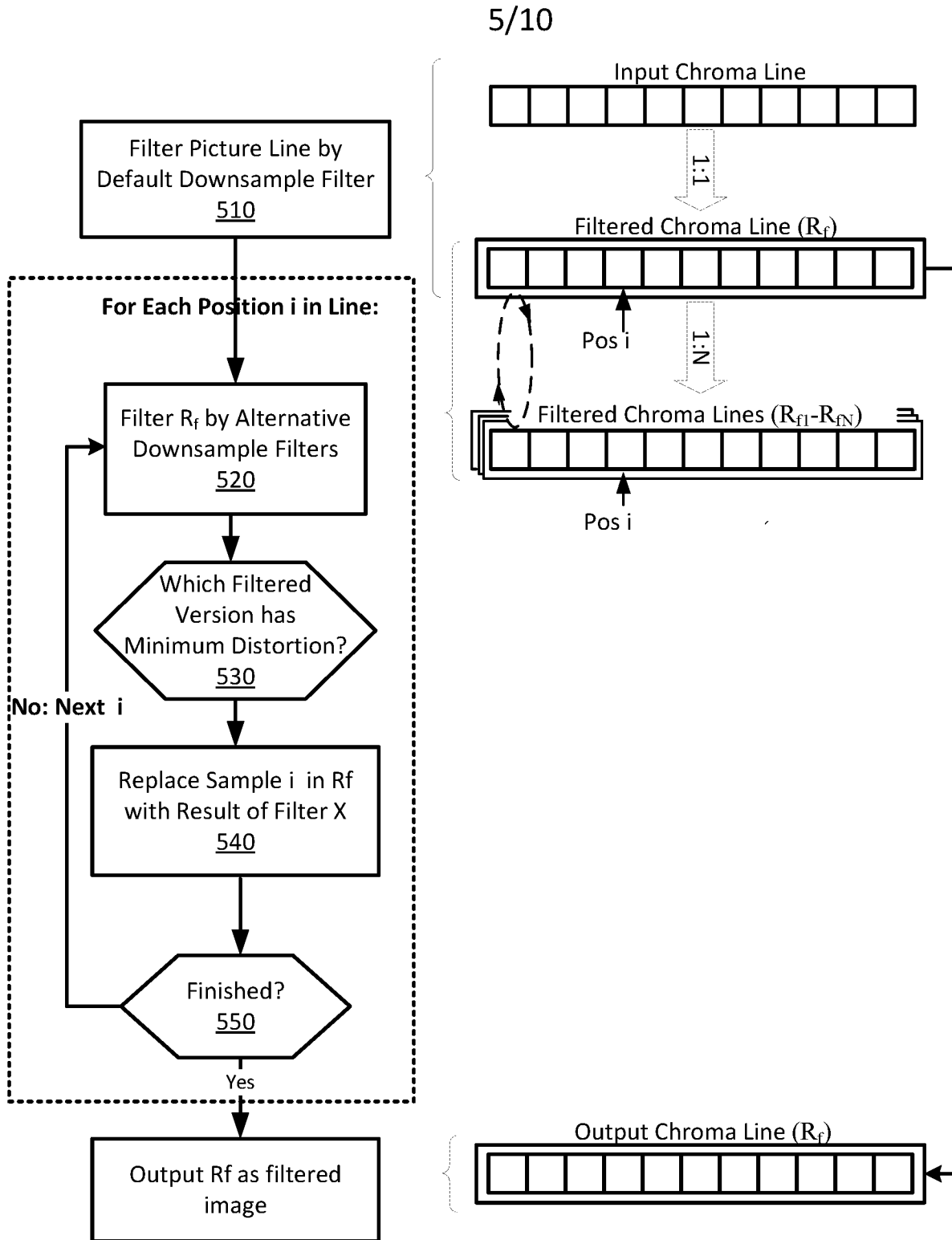

FIG. 5

6/10

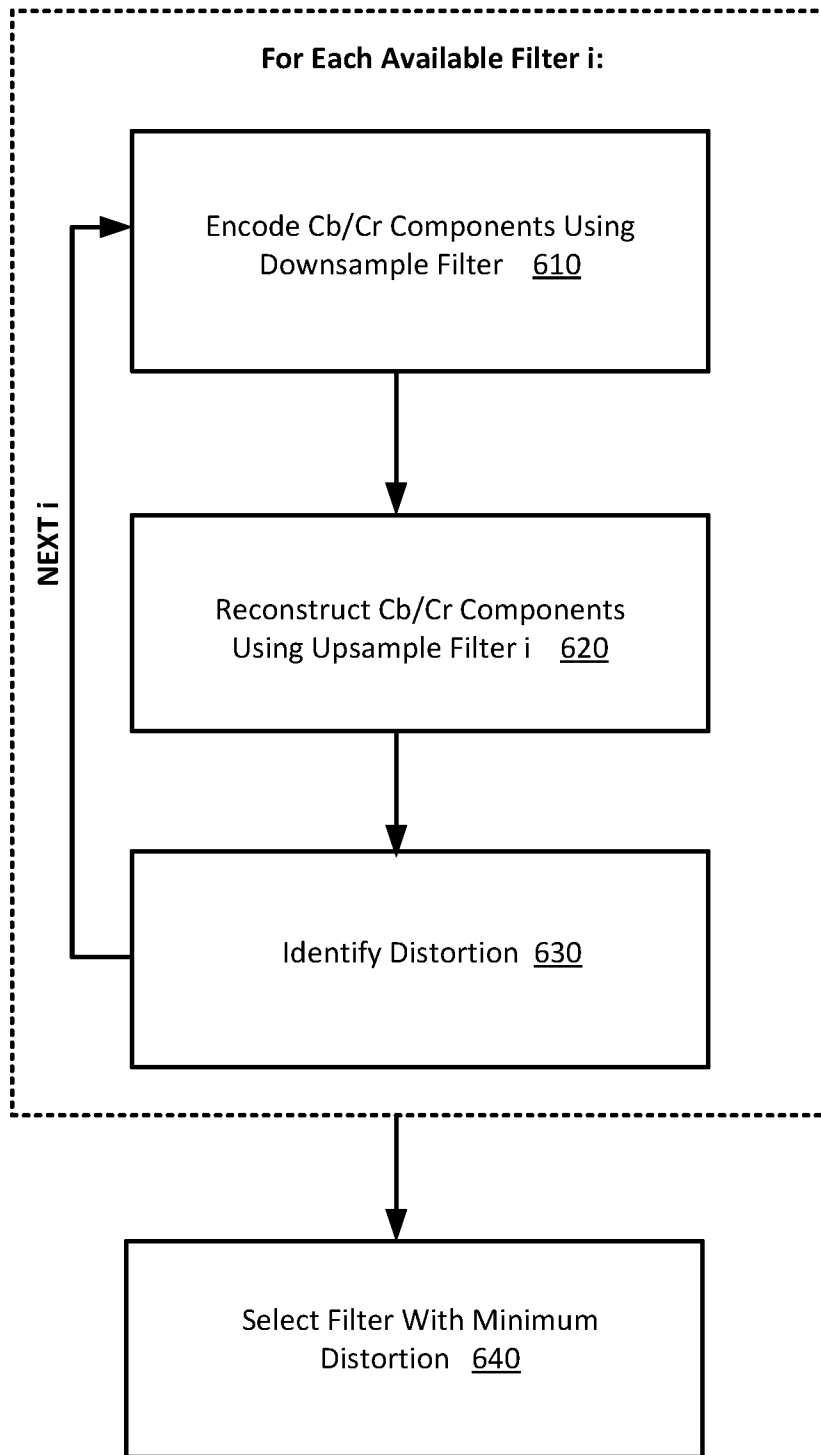

FIG. 6

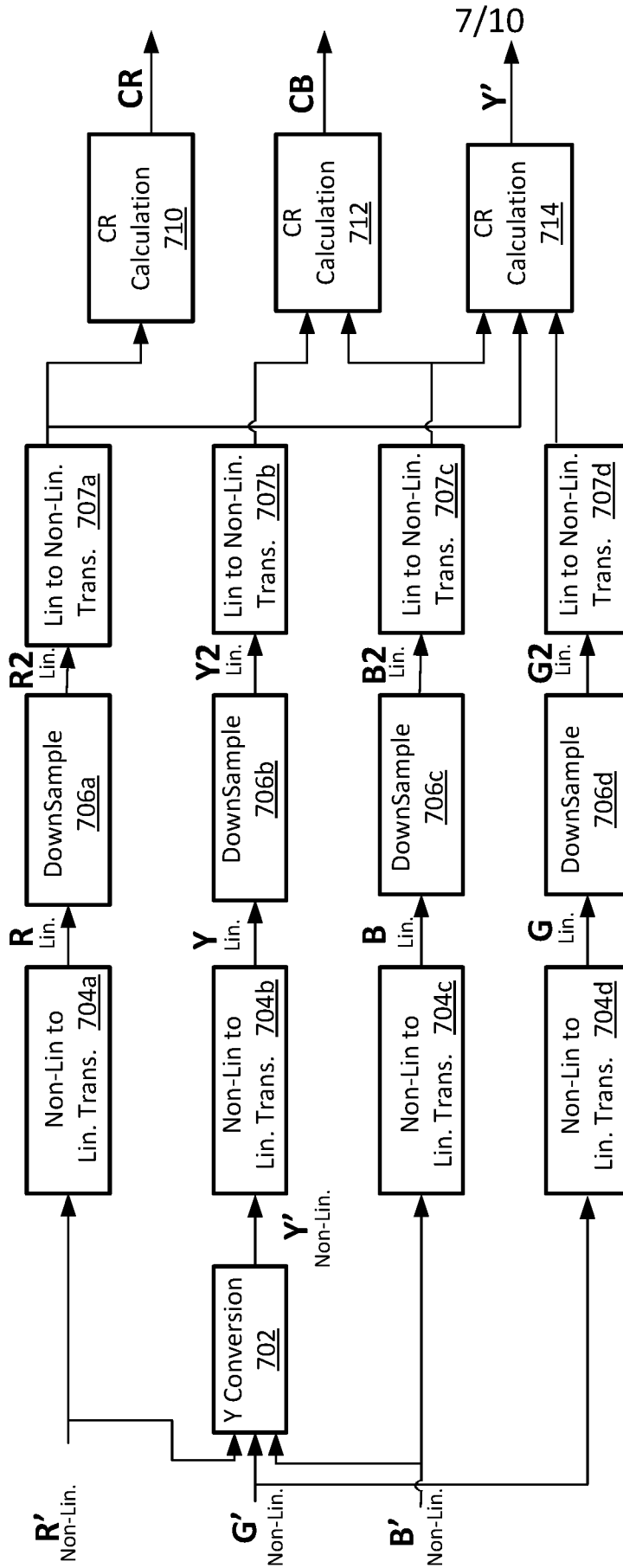

FIG. 7

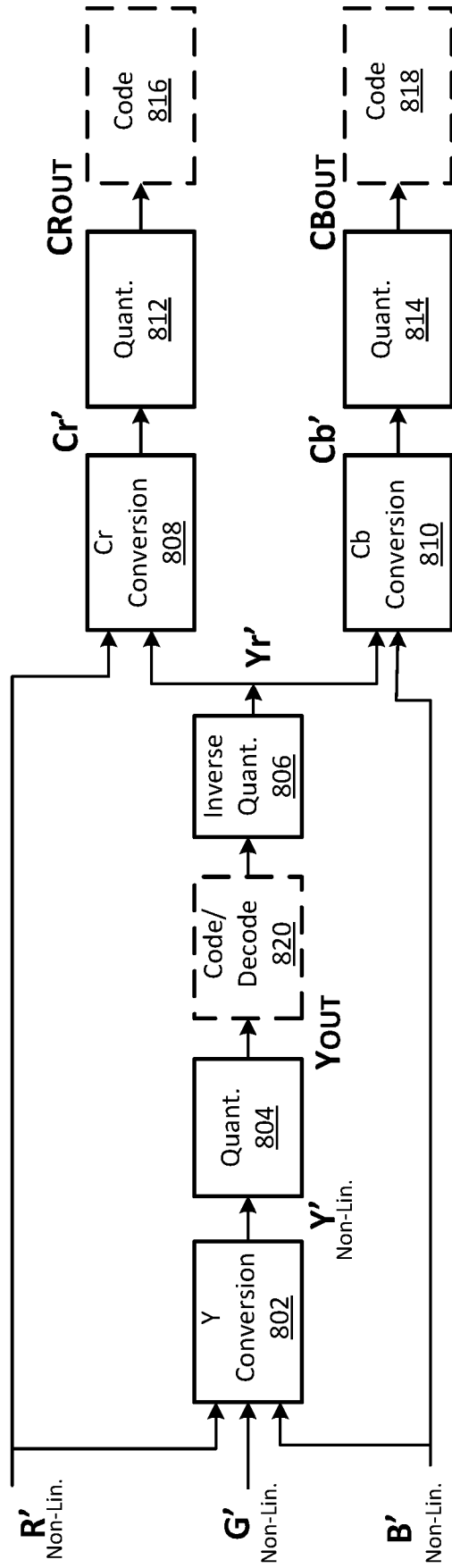

FIG. 8

FIG. 9

900

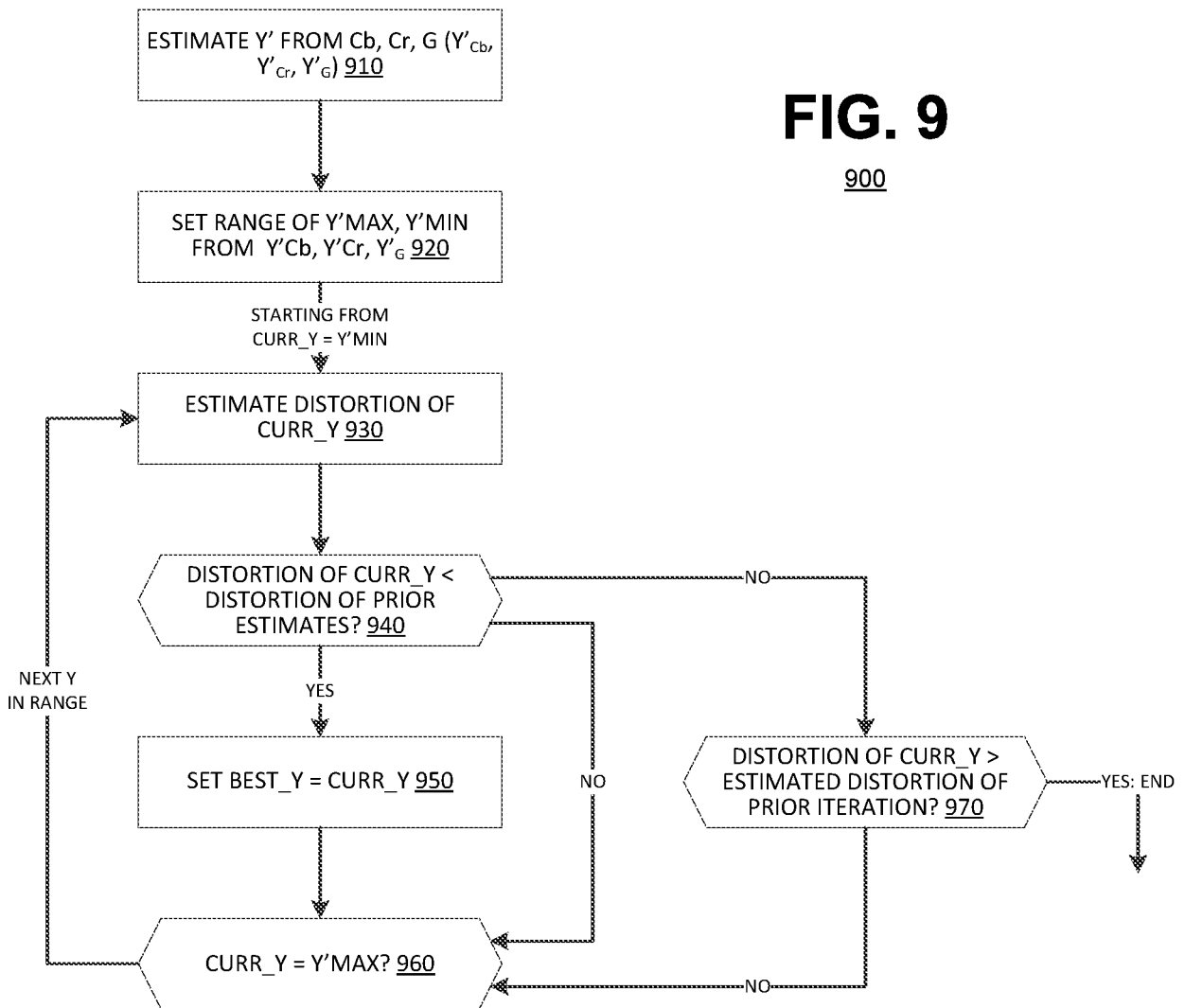
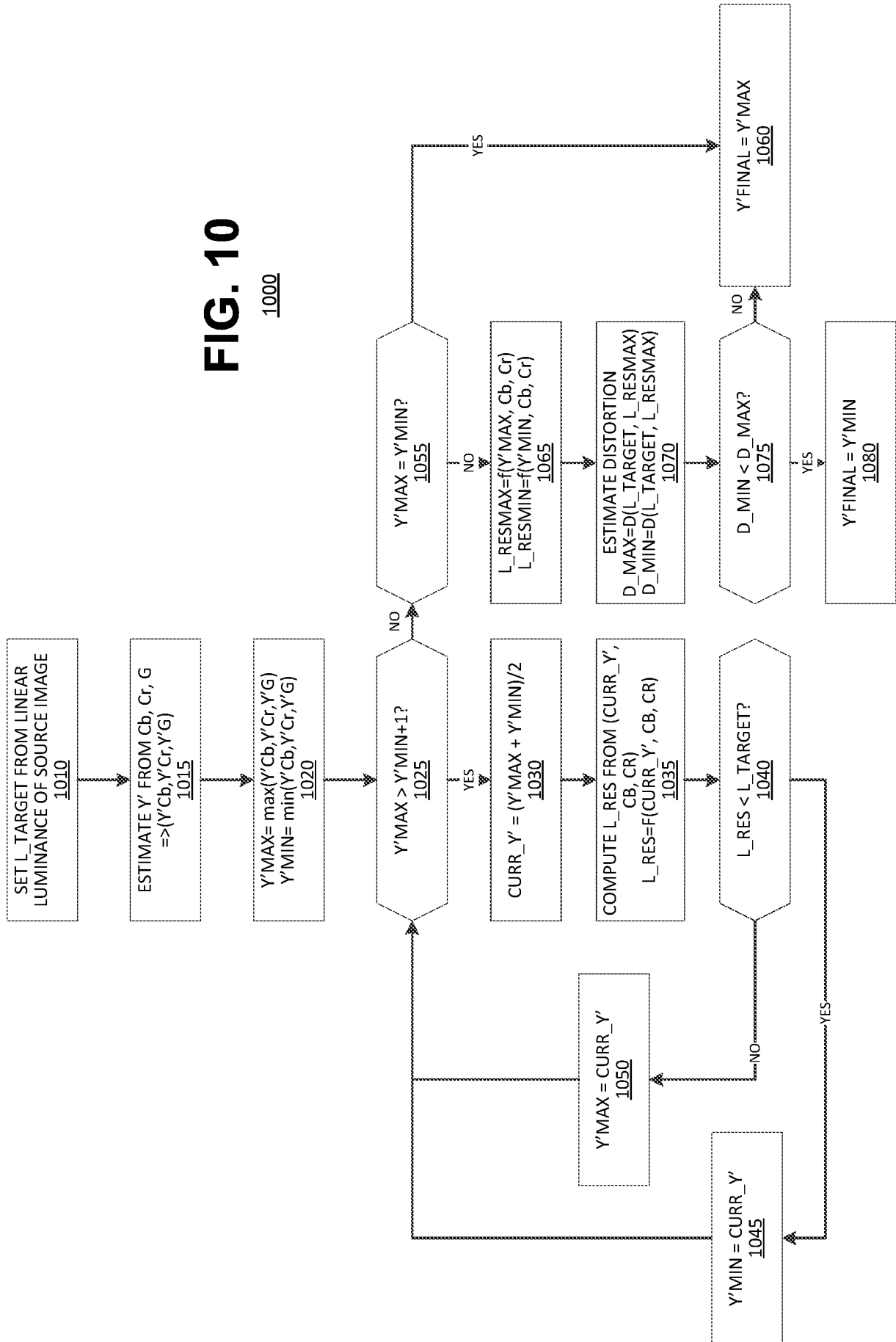

FIG. 10

1000



INTERNATIONAL SEARCH REPORT

International application No
PCT/US2016/061712

A. CLASSIFICATION OF SUBJECT MATTER
INV. H04N1/64 H04N9/67 H04N9/64
ADD.
According to International Patent Classification (IPC) or to both national classification and IPC

B. FIELDS SEARCHED
Minimum documentation searched (classification system followed by classification symbols)
H04N
Documentation searched other than minimum documentation to the extent that such documents are included in the fields searched

Electronic data base consulted during the international search (name of data base and, where practicable, search terms used)
EPO-Internal, WPI Data

C. DOCUMENTS CONSIDERED TO BE RELEVANT		
Category*	Citation of document, with indication, where appropriate, of the relevant passages	Relevant to claim No.
X	WO 98/27745 A1 (THOMSON BRANDT GMBH [DE]; BRUCK GUIDO [DE]) 25 June 1998 (1998-06-25)	1,6,8, 13,15,20
A	page 8, line 1 - page 13, line 8; figures 3, 4, 5	2-5,7, 9-12,14, 16-19,21
X	----- EP 0 176 093 A1 (TELEFUNKEN FERNSEH & RUNDFUNK [DE]) 2 April 1986 (1986-04-02)	1,2,6,8, 9,13,15, 16,20
A	page 3, line 9 - page 16, line 17; figures 1-15 -----	3-5,7, 10-12, 14, 17-19,21

Further documents are listed in the continuation of Box C.

See patent family annex.

* Special categories of cited documents :

- "A" document defining the general state of the art which is not considered to be of particular relevance
- "E" earlier application or patent but published on or after the international filing date
- "L" document which may throw doubts on priority claim(s) or which is cited to establish the publication date of another citation or other special reason (as specified)
- "O" document referring to an oral disclosure, use, exhibition or other means
- "P" document published prior to the international filing date but later than the priority date claimed

- "T" later document published after the international filing date or priority date and not in conflict with the application but cited to understand the principle or theory underlying the invention
- "X" document of particular relevance; the claimed invention cannot be considered novel or cannot be considered to involve an inventive step when the document is taken alone
- "Y" document of particular relevance; the claimed invention cannot be considered to involve an inventive step when the document is combined with one or more other such documents, such combination being obvious to a person skilled in the art
- "&" document member of the same patent family

Date of the actual completion of the international search
8 February 2017

Date of mailing of the international search report
16/02/2017

Name and mailing address of the ISA/
European Patent Office, P.B. 5818 Patentlaan 2
NL - 2280 HV Rijswijk
Tel. (+31-70) 340-2040,
Fax: (+31-70) 340-3016

Authorized officer
Seytter, Fritz

INTERNATIONAL SEARCH REPORT

Information on patent family members

International application No

PCT/US2016/061712

Patent document cited in search report	Publication date	Patent family member(s)	Publication date
WO 9827745	A1	25-06-1998	
		AU 5560998 A	15-07-1998
		CN 1238101 A	08-12-1999
		DE 19652362 A1	18-06-1998
		EP 0947106 A1	06-10-1999
		JP 3682927 B2	17-08-2005
		JP 2001506437 A	15-05-2001
		US 6519289 B1	11-02-2003
		WO 9827745 A1	25-06-1998
EP 0176093	A1	02-04-1986	
		EP 0176093 A1	02-04-1986
		HK 57391 A	02-08-1991