

(19) **DANMARK**

(10) **DK/EP 3222148 T3**



Patent- og
Varemærkestyrelsen

(12) **Oversættelse af
europæisk patentskrift**

-
- (51) Int.Cl.: **A 23 G 1/18 (2006.01)** **A 23 G 1/00 (2006.01)** **A 23 G 3/02 (2006.01)**
A 23 G 3/34 (2006.01)
- (45) Oversættelsen bekendtgjort den: **2019-07-29**
- (80) Dato for Den Europæiske Patentmyndigheds bekendtgørelse om meddelelse af patentet: **2019-05-08**
- (86) Europæisk ansøgning nr.: **16000711.8**
- (86) Europæisk indleveringsdag: **2016-03-24**
- (87) Den europæiske ansøgnings publiceringsdag: **2017-09-27**
- (84) Designerede stater: **AL AT BE BG CH CY CZ DE DK EE ES FI FR GB GR HR HU IE IS IT LI LT LU LV MC MK MT NL NO PL PT RO RS SE SI SK SM TR**
- (73) Patenthaver: **Bühler GmbH, Daimlerstrasse 8, 74211 Leingarten, Tyskland**
- (72) Opfinder: **Grötsch, Heiko, Kremper Str. 4, 20251 Hamburg, Tyskland**
HILTSCHER, Markus, Susebekweg 10, 22339 Hamburg, Tyskland
Schieritz, Peter, Weckmannweg 8, 20257 Hamburg, Tyskland
- (74) Fuldmægtig i Danmark: **RWS Group, Europa House, Chiltern Park, Chiltern Hill, Chalfont St Peter, Bucks SL9 9FG, Storbritannien**
- (54) Benævnelse: **TEMPERERINGSMODUL**
- (56) Fremdragne publikationer:
EP-A2- 0 727 147
DE-A1- 19 637 098
DE-U1-202014 001 005
GB-A- 826 502
GB-A- 2 186 476
US-A- 3 291 031

Description

The present invention relates to a tempering module for a tempering machine for controlling the temperature of a food mass. The present invention relates further to a tempering machine having at least one tempering module of this kind.

Tempering machines and tempering modules are known from the prior art. One of the tempering modules known from the prior art is shown in Figs. 12 to 14 wherein Fig. 14 shows a sectional view along the cross-section line A-A in Fig. 13. This tempering module 200 comprises a tempering tube 201 and a worm gear 202. The tempering tube 201 comprises an inner tube 203 and an outer tube 204 (Fig. 14). Connecting flanges 205 and 206 are arranged at the ends of the tempering tube 201 and at the ends of the inner tube 203 and the outer tube 204 respectively. The connecting flanges 205 and 206 are braced against one another by tie rods 207. For this, the connecting flanges 205 and 206 have openings into which the tie rods 207 can be inserted. Nuts 208 are provided to tension the connecting flanges 205 and 206 via the tie rods 207. In Figs. 12 and 14 the drive of the worm gear 202 is marked by reference numeral 209. The drive 209 comprises gear rings 210 and 211 which can be driven by a motor (not shown) via chain drives (not shown). The motor is arranged spaced from the tempering module 200.

As a result of the plurality of individual parts, the tempering module 200 shown in Figs. 12 to 14 can only be cleaned with a relatively great deal of time since for cleaning, inter alia, the nuts 208 of the tie rods 207 have to be released and the tie rods 207 have to be dismantled. Furthermore, dirt and impurities can collect at the joining places or joining gaps, by way of example between the inner tube 204 of the tempering tube 201 and the connecting flanges 205, 206, which must be avoided at all costs for hygienic reasons during the production of foods or when handling food masses.

GB 826 502 A1 discloses a device which has worm gears arranged

in two cylinders. Channels are formed round the worm gears in the two cylinders through which a tempering medium can be passed.

5 The object of the present invention is to provide a tempering module of the type mentioned at the beginning which with a simple structure prevents contamination in the food mass and which can be rapidly and hygienically cleaned.

10 This is achieved with a tempering module of the type mentioned at the beginning having the features of claim 1.

Further embodiments are apparent from the dependent claims.

15 The tempering module according to the invention for a tempering machine for tempering a food mass comprises

- at least one worm gear, and
- at least one tempering tube into which the worm gear can
20 be inserted. The tempering tube and the worm gear delimit a food mass conveying channel between them. The tempering tube comprises at least one inner tube and at least one outer tube. The inner tube and the outer tube delimit at least one tempering chamber between them. According to the invention the inner tube
25 and the outer tube are connected permanently fixed connected to one another.

30 With the tempering module according to the invention, as a result of the permanently fixed connection between the at least one inner tube and the at least one outer tube, the tempering tube can be handled as a separate one-piece unit which enables a hygienic processing of the food mass and which ensures rapid simple cleaning of the tempering module. The tempering tube has no releasable joining points or joining gaps where impurities
35 could collect. Furthermore, through the permanently fixed connection of the at least one inner tube and the at least one outer tube it can be guaranteed that no impurities can be introduced from the tempering chamber into the food mass

conveying channel and thus into the food mass.

With the tempering module according to the invention only the interior circumferential surface of the tempering tube can come
5 into contact with the food mass. If the food mass which is to be tempered with the tempering module has to be replaced, then it is sufficient to clean the interior circumferential surface or the inner tube of the tempering tube and then remove the residues of the food mass. After cleaning the worm gear and
10 fitting the tempering module back together again, the tempering module can then be used for tempering a new food mass without the new food mass becoming contaminated with residues of the previous food mass. In this way a rapid change of food mass is achieved through the tempering module according to the
15 invention.

According to one embodiment of the invention, the tempering tube can comprise at least one first connecting flange and at least one second connecting flange. The first connecting flange and
20 the second connecting flange can connect the inner tube and the outer tube permanently fixedly to one another. The inner tube and the outer tube can, together with the first connecting flange and the second connecting flange, form one structural unit permanently fixedly connected to one another. This unit can be
25 handled and cleaned as one part. As a result of the permanently fixed connection no joining gaps are formed between the inner tube and the outer tube or between the first connecting flange and the second connecting flange. No connecting means or means for tensioning the connecting flanges, such as for example the
30 tie rods known from the prior art, are required for connecting the inner tube and the outer tube with the connecting flanges. The connecting flanges can delimit the tempering chamber at the axial ends of the inner tube and the outer tube. In other words, the tempering chamber can be delimited by the inner tube, the
35 outer tube, the first connecting flange and the second connecting flange. The connecting flanges can extend at least in some sections between the inner tube and the outer tube to delimit the at least one tempering chamber

The inner tube, the outer tube, the first connecting flange and the second connecting flange can be connected to one another by material bonding. In particular the inner tube, the outer tube, 5 the first connecting flange and the second connecting flange can be welded to one another. It is however also conceivable that these components of the tempering module are connected to one another via another type of material-bonding connection, such as for example adhesive bonding. Where possible all components 10 which are connected to one another by material bonding, in particular by welding, are made from stainless steel.

The first connecting flange can be connected with at least one connecting piece for a motor. The motor can serve to drive the 15 worm gear. The motor can be attached directly on the at least one connecting piece. The motor can be connected to the tempering tube via the connecting piece. The connecting piece can form an intermediate member between the motor and the first connecting flange or tempering tube. As a result of its direct 20 connection with the tempering tube via the connecting piece the motor can be rapidly dismantled from the tempering tube for cleaning.

The second connecting flange can be connected to a closure 25 element on which the worm gear is mounted and which forms one end of the tempering module.

The closure element can be removably connected to the second connecting flange for removing the at least one worm gear. By 30 way of example the closure element can be screwed to the second connecting flange. In order to make it easier for a user to reach the worm gear in the tempering tube, the screws can be designed by way of example in the form of handle screws or wing nuts. The handle screws can be by way of example star handle 35 screws. With screws of this kind, the user can dismantle the closure element without additional tools in order to remove the worm gear from the tempering tube

The motor can be connected to the at least one worm gear via at least one shaft. The motor can drive the worm gear directly via the shaft. The shaft can be extended by the connecting piece. As mentioned previously above, the motor can be attached to the
5 at least one connecting piece and can be coupled to the tempering tube via the connecting piece. In order to clean the tempering module the motor can be rapidly and easily released from the tempering tube and the worm gear by dismantling the connecting piece from the tempering tube. The motor can be screwed by way
10 of example to the at least one connecting piece which in turn can be screwed to the at least one tempering tube.

The first connecting flange and the second connecting flange can each have an inlet opening for inserting the food mass into the
15 food mass conveying channel or at least one outlet opening for discharging the food mass from the food mass conveying channel. In other words, either the first connecting flange has an inlet opening and the second connecting flange has an outlet opening or the first connecting flange has an outlet opening and the
20 second connecting flange has an inlet opening. Which arrangement of inlet opening and outlet opening is used depends accordingly on the further components connected to the tempering module which supply the food mass to the tempering module or to which the food mass is supplied from the tempering module. A
25 component to which food mass can be supplied from a tempering module can be a further tempering module.

The tempering chamber can have one or more tempering channels, preferably at least one first tempering channel and at least one
30 second tempering channel. The first tempering channel and the second tempering channel can be separated via at least one separating element in the at least one tempering chamber. The at least one separating element can be a separating ring. In order to be able to control the temperature of the food mass as
35 efficiently as possible to a predetermined target temperature, at least two tempering channels are formed which do not extend over the entire length of the tempering tube, but only over partial sections of the tempering tube. The first tempering

channel and the second tempering channel thus extend over a predetermined section of the tempering tube so that each tempering channel can bring the food mass in the food channel to the temperature assigned to the respective tempering channel.

5

The first tempering channel and the second tempering channel can extend substantially helically through the tempering chamber. For this, ribs or walls can be provided in the tempering chamber to determine and delimit the helical turns for the two tempering channels in the tempering chamber. The walls or ribs can themselves extend helically through the tempering channels. This can be achieved by way of example by inserting a substantially helically formed round steel or square steel.

15 The tempering tube can have connections via which the first tempering channel and the second tempering channel can be coupled to a first tempering circuit and to a second tempering circuit for supplying a tempering fluid. In other words, each tempering channel is assigned a separate tempering circuit. Each tempering channel can have a supply connection and a discharge connection for the tempering fluid. The supply connection and the discharge connection are each provided at one end of the first tempering channel and the second tempering channel. Since each tempering channel can be coupled to a tempering circuit, a predetermined temperature of the tempering fluid can be set and maintained which is suitable for tempering the food mass. In this way it can be ensured that food mass has the predetermined temperature in the food mass conveying channel at the end of the tempering tube or tempering module. The food mass in the food conveying channel can be continuously brought to the predetermined temperature through coupling the tempering channels to the separate or individual tempering circuits.

35 The tempering tube can have at least one connection for controlling the temperature of the food mass in the food mass conveying channel. The connection for temperature control can extend through the outer tube and the inner tube up to the food mass conveying channel. The connection for temperature control

can be provided with a temperature sensor or coupled to a temperature sensor.

5 The present invention further relates to a tempering machine for tempering a food mass with at least one tempering module of the type described above.

10 According to one embodiment the tempering machine can have several tempering modules of the type previously described. The individual tempering modules can each be coupled via a connecting channel for conveying the food mass from one tempering module to the tempering module lying downstream in the mass flow. The connecting channel can extend by way of example between connecting flanges of adjacent tempering modules and can
15 couple these connecting flanges to one another.

The connecting channel can, for conveying the food mass from one tempering module to the next tempering module, couple an outlet opening of one tempering module with an inlet opening of the
20 next tempering module.

The tempering module can be arranged on at least one movable or stationary frame. The tempering module can be arranged in particular horizontally on the at least one frame. If the frame
25 is designed to be displaceable then the frame can also be displaced in the vertical direction between a production position and a moving position. For this the frame can have a lever assembly. The lever assembly can be configured so that it can move the tempering machine between the production
30 position and a moving position. In the moving position the tempering machine can then be relatively moved. In the moving position the tempering machine can be brought away from the production position and the production line by way of example to a cleaning station. The lever assembly can be actuated by
35 way of example in a first direction in order to move the tempering machine from the production position into the moving position, and in a second direction in order to transfer the tempering machine from the moving position into the production

position. The control and handling of the at least one lever assembly is accordingly relatively simple.

5 The tempering machine can furthermore comprise a control. The control of the tempering machine can be mounted in a switch cabinet. The control of the tempering machine can be designed separately from the control of further assemblies of a production line for manufacturing food products. The tempering machine can likewise have water circuits assigned solely to the
10 tempering machine. The tempering machine can thus be controlled and supplied with water independently of the further assemblies of a production line. The further assemblies of a production line can be by way of example a tank containing the food mass, and a coating device for coating food products with the food
15 mass. The food mass from the tank is supplied to the tempering machine, brought in the tempering machine to a predetermined temperature suitable for coating the food products, and then supplied to a coating device which can coat the food products with the tempered food mass.

20

With a further development of the invention it can be proposed in particular that the tempering machine is designed to be arranged adjacent a material storage container for storing the food mass and/or adjacent to a device for further processing the
25 food mass, in particular a food mass coating machine and/or a food mass decorating machine and/or a food mass pouring machine. It is then possible that the material storage container is arranged directly in front of the tempering machine or with the interposition of further components. It is equally possible
30 that the food mass processing device is arranged directly downstream of the tempering machine or with the interposition of further components.

The present invention further relates to a method for tempering
35 a food mass with a tempering module of the type described above, wherein a tempering fluid, in particular a glycol-containing water or other suitable fluid, flows through the tempering chamber in order to control the temperature of the food mass in

the food mass conveying channel.

A further development of the method according to the invention proposes that the food mass is introduced into a first tempering
5 channel which forms a decrystallization stage for the food mass, wherein the food mass is further directly or indirectly led from the first tempering channel into a second tempering channel which forms a cooling stage, and wherein the food mass is led from the second tempering channel into a third tempering channel
10 which forms a warming stage, wherein in particular each of the tempering channels can be supplied with the tempering fluid via a separate tempering fluid circuit. It is also possible to assign more than one tempering channel to the decrystallization stage and/or to the cooling stage and/or to the warming stage,
15 and to configure these so that they extend over several tempering modules. A predetermined temperature level can be set in the food mass in each of the components decrystallization stage, cooling stage(s) and warming stage. The decrystallization stage and the warming stage are optional and can also be omitted.

20 According to the invention it can be proposed that this temperature level is reached by controlling the temperature and the through-flow of the respective tempering fluid in the associated tempering fluid circuit and/or by controlling the
25 conveying speed of the food mass through the respective tempering channel in accordance with the length of the respective tempering channel. By suitably adjusting and controlling these parameters, a predetermined residence time of the food mass in the respective tempering channel is set and
30 thus the desired temperature level is reached in the food mass during the process. A selective adjustable temperature gradient is thus achieved overall over the entire tempering machine.

Exemplary embodiments of the invention will now be described
35 below with reference to the accompanying drawings. In the drawings:

Fig 1 shows a front view of a tempering module

according to the invention;

Fig. 2 shows a front view, partially transparent, of the tempering module according to the invention;

5

Fig. 3 shows a sectional view along the section line III-III in Fig. 2;

Fig. 4 shows a sectional view along the section line IV-IV in Fig. 2;

10

Fig. 5 shows an enlarged view of the detail V-V in Fig. 4;

Fig. 6 shows a front view, partially transparent, of a tempering tube according to the invention;

15

Fig. 7 shows a side view, partially transparent, of the tempering tube according to the invention;

20

Fig. 8 shows a perspective view of the tempering machine according to the invention in the cleaning stage;

Fig. 9 shows a perspective of the tempering machine according to the invention in the production stage;

25

Fig. 10 shows an enlarged view of the detail X in Fig. 9;

Fig. 11 shows a diagrammatic illustration for explaining the temperature control of the tempering machine;

30

Figs. 12-14 show illustrations of the prior art.

Fig. 1 shows a front view of a tempering module 10.

35

The tempering module 10 comprises a tempering tube 12. The first connecting flange 24 and the second connecting flange 26

are arranged at the ends of the tempering tube 12. A connecting piece 28 is fixed on the first connecting flange 24. The motor 30 is attached to the connecting piece 28. The motor 30 is thus coupled directly to the tempering tube 12 via the connecting piece 28. The second connecting flange 26 is provided with a closure element 32. The closure element 32 is screwed to the second connecting flange 26 via screws 56. The screws 56 can be handle screws, in particular star handle screws.

10 Connections 46, 48, 50 and 52 can be seen on the tempering tube 12. The connections 46, 48 and the connections 50, 52 are each assigned to a tempering channel 40, 42 formed in the tempering tube 12 (see Fig. 2). The first tempering channel 40 and the second tempering channel 42 (Fig. 2) can be supplied with
15 tempering fluid via the connections 46, 48, 50, 52. The tempering fluid is glycol-containing water.

The further connection 54 which can be seen in Fig. 1 serves to control the temperature of the food mass. The connection 54 can
20 have a temperature sensor (not shown) or can be coupled to a temperature sensor.

Fig 2 shows a front view of the tempering module 10 with a tempering tube 12 shown partly transparent.

25

The tempering tube 12 has an inner tube 18 and an outer tube 20. The inner tube 18 is arranged substantially coaxially with the outer tube 20. The inner tube 18 and the outer tube 20 delimit a tempering chamber 22 between them. The first tempering channel
30 40 and the second tempering channel 42 are formed in the tempering chamber 22 and are separated by a ring-shaped separating element 44. The tempering channels 40, 42 extend helically through the tempering chamber 22. The helical-shaped tempering channels 40, 42 are formed by ribs or walls 58 which
35 likewise extend helically through the tempering chamber 22.

The first tempering channel 40 has the connections 46, 48 via which the tempering channel 40 can be coupled to a tempering

circuit. One of the connections 46 or 48 forms an inlet for the tempering fluid. The respective other connection 46 or 48 forms an outlet for the tempering fluid. The same applies for the connections 50, 52 of the second tempering channel 42.

5

The inner tube 18, the outer tube 20, the first connecting flange 24 and the second connecting flange 26 are connected permanently fixed to one another through material bonding. In particular the said components of the tempering tube 12 can be welded to one another. The tempering tube 12 represents a one-piece unit which encloses the tempering chamber 22 in same. The tempering chamber 22 in the tempering tube 12 is closed in itself except for the connections 46, 48, 50, 52.

15 Fig. 2 also shows the connection 54 for controlling the temperature of the food mass. The connection 54 is formed on the tempering tube 12 and extends up to the inner circumferential surface of the inner tube 18. The connection 54 forms a passage through the tempering tube 12 up to the food mass conveying channel 16 (Fig. 3).

20 Fig. 3 shows a sectional view along the section line III-III in Fig. 2.

25 The tempering module 10 comprises a worm gear 14 arranged in the tempering tube 12. The tempering tube 12 and the worm gear 14 delimit a food mass conveying channel 16 between them.

The worm gear 14 has a coupling element 60. The coupling element 30 60 is arranged at the end of the worm gear 14 facing the motor 30. The coupling element 60 is connected to a shaft 34. The coupling element 60 is coupled to the motor 30 via the shaft 34. The shaft 34 extends through the connecting piece 28 from the motor 30 to the coupling element 60 of the worm gear 14. The 35 worm gear 14 has a further coupling element 62 at its end facing the closure element 32. A bearing section 64 is formed on the coupling element 62. The bearing section 64 is designed in the form of a bearing projection or a bearing pin. The bearing

section 64 on the coupling element 62 is received for mounting the worm gear 14 in a bearing point 66 on the closure element 32. The bearing point 66 on the closure element 32 can be formed as a cylindrical recess which receives the bearing section 64.

5 After removing the closure element 32, the worm gear 14 can be removed from the tempering tube 12, by way of example for cleaning purposes.

The inner tube 18 and the outer tube 20 together with the first
10 connecting flange 24 and the second connecting flange 26 delimit the tempering chamber 22 in the tempering tube 10. The first tempering channel 40 and the second tempering channel 42 are formed in the tempering chamber 22. The first tempering channel 40 and the second tempering channel 42 are separated via a
15 separating element 44 in the form of a separating ring. The first tempering channel 40 extends over about two thirds of the length of the tempering tube 12. The second tempering channel 42 correspondingly occupies about one third of the length of the tempering tube 12. The tempering tube 12 and the tempering
20 channels 40 and 42 formed therein surround the food mass conveying channel 16, which is fixed between the inner tube 14 of the tempering tube 12 and the worm gear 14, in order to control the temperature of the food mass moved by the worm gear 14 in the food mass conveying channel 16.

25

Fig. 4 shows a sectional view along the section line IV-IV in Fig. 2.

Fig. 4 shows the tempering tube 12 and the worm gear 14 of the
30 tempering module 10. The connections 48 and 50 are formed on the tempering tube 12 for supplying the first tempering channel 40 and the second tempering channel 42 with tempering fluid.

Fig. 4 further shows the connection 54 for the temperature
35 control which is arranged in the sectional view according to Fig. 4 between the connections 48 and 50.

Fig. 5 shows an enlarged detailed view of detail V in Fig. 4.

The inner tube 18 and the outer tube 20 of the tempering tube 12 delimit the tempering chamber 22 between them. The second tempering channel 42 of the tempering chamber 22 is shown in sectional view in Fig. 5.

The connections 48 and 50 are provided on the tempering tube 12 via which the tempering chamber 22 and the tempering channels 40 and 42 can be supplied with tempering fluid. The connection 50 is of tubular design. The connection 50 changes into an opening 68 in the outer tube 20 of the tempering tube 12. The opening 68 opens into the second tempering channel 42 of the tempering chamber 22. Tempering fluid can thus be supplied to the second tempering channel 42 or discharged from the second tempering channel 42 via the connection 50 and the opening 68. The same also applies for the further connections 46, 48, 52. In Fig. 5 only the connection 50 is shown in section so that the description is based on this connection 50 shown in section. The effect of the division into different tempering channels will be explained below with reference to Fig. 11.

The food mass conveying channel 16 is delimited between the inner tube 18 of the tempering tube 12 and the worm gear 14, with the food mass being conveyed along the tempering tube 12 in the channel through the effect of the rotating worm gear 14. The connection 54 for temperature control extends through the tempering tube 12, i.e. through the inner tube 18 and the outer tube 20 up to this food mass conveying channel 16. The connection 54 for temperature control has a temperature sensor 70 with which the temperature of the food mass can be measured or determined.

Fig. 6 shows a front view of a tempering tube 12, shown partly transparent.

The tempering tube 12 represents a separate unit which can be handled as one part. The tempering tube 12 comprises the inner tube 18, the outer tube 20, the first connecting flange 24 and

the second connecting flange 26. The inner tube 18, the outer tube 20, the first connecting flange 24 and the second connecting flange 26 are connected permanently fixed to one another. The said components can in particular be welded to one another.

5 Connecting the components of the tempering tube 12 permanently fixed together into one unit or assembly prevents dirt and impurities from collecting at the joining gaps and from contaminating the food mass in the food mass conveying channel 16. Connecting the inner tube 18, outer tube 20, first

10 connecting flange 24 and second connecting flange 26 and the thereby substantially closed tempering chamber 22 permanently fixed to one another can likewise prevent tempering fluid from the tempering chamber 22 entering into the food mass conveying channel 16 and contaminating the food mass. As a result of the

15 tempering tube 12 formed as a structural unit, cleaning the tempering module 10 can be simplified and accelerated since no parts of the tempering tube 12 have to be dismantled and laboriously cleaned individually. As a result of the permanently fixed connection of the components of the tempering

20 tube 12 to one another it is sufficient to clean the internal circumferential surface of the tempering tube 10 since no further components or parts of the tempering tube 12 can come into contact with the food mass.

25 Fig. 6 shows the inlet openings and outlet openings 36, 38 in the first connecting flange 24 and the second connecting flange 26 respectively. Food mass can be introduced into the tempering module 10 or into the food mass conveying channel 16, or discharged from the food mass conveying channel 16, via the

30 openings 36, 38. The openings 36, 38 extend substantially radially through the connecting flanges 24, 26. A pressure sensor (not shown in detail) can also be arranged on the outlet opening 38 to detect for example a rise or fall in pressure. This can indicate by way of example an unacceptably severe

35 crystallization of the food mass in the associated tempering module 10 so that action is required in the temperature control, which will be explained below.

Fig. 7 shows a side view of the tempering tube 12 according to Fig. 6.

5 It is apparent in Fig. 7 that the tempering tube 12 has a constant inner diameter. There are no shoulders or the like on the tempering tube 12 where impurities could collect. The constant internal diameter of the tempering tube 12 thus likewise aids a rapid simple cleaning of the tempering tube 12.

10 Fig. 8 shows a perspective view of a tempering machine 100 and the switch cabinets 150.

The control of the tempering machine 100 is housed in the switch cabinets 150. The tempering machine 100 has its own control
15 which is independent of the control of the further components of a production line for producing food products. The tempering machine 100 can be connected to a tank (not shown) which supplies the tempering machine 100 with food mass. After tempering the food mass with the tempering machine 100 the tempered food mass,
20 by way of example chocolate, can be supplied to a coating device (not shown) with which the food products can be coated with a layer of food mass (chocolate).

Fig. 8 shows the tempering machine 100 in the cleaning stage.
25 The tempering machine 100 comprises four tempering modules 10₁, 10₂, 10₃, 10₄ which are arranged horizontally on a movable frame 102. The movable frame 102 has a lifting carriage 106. The frame 102 can be moved via the lever assemblies 108 from a production position in which the frame 102 is supported by the
30 feet 110 on the foundation, into a movement position in which the frame 102 is supported on the foundation via the wheels 112, and back again into the production position. The tempering machine 100 can be raised or lowered vertically via the lever assemblies 108.

35

That the tempering machine 100 is located in Fig. 8 in the cleaning stage, is apparent through the tempering module 10₄ which is partly dismantled. The worm gear 14 was removed from

the tempering tube 12 of the tempering module 10₄ and deposited onto a rolling truck 114. The connecting piece 28 was furthermore dismantled with the motor 30 from the tempering tube 12. Since the worm gear 14 is driven directly by the motor 30 via the shaft 34 (see Fig. 3), the worm gear 14 can be released relatively quickly and easily from the motor 30 for cleaning the tempering module 10₄. The frame 102 can have a holder 116 on which the dismantled components can be deposited. Furthermore, the motor 30 can be moved on the holder 116 as it is removed.

10

Fig. 9 shows a perspective view of the tempering machine 100 and the switch cabinets 150 in the production stage.

In the production stage, a food mass can be tempered with the tempering machine 100. For this, the food mass is guided through an inlet opening 36 of the tempering modules 10₄ into the tempering module 10₄ and conveyed along the arrow R1 through the tempering module 10₄. The tempering module 10₄ is coupled to the tempering module 10₃ via the connecting channel 104. Food mass can be guided via the connecting channel 104 from the tempering module 10₄ into the tempering module 10₃. The food mass is conveyed in the direction of the arrow R2 through the tempering module 10₃. The tempering module 10₃ is in turn connected to the tempering module 10₂ via a connecting channel (not shown). The food mass is conveyed in the direction of the arrow R3 through the tempering module 10₂. The tempering module 10₂ is connected via a connecting channel 104 to the tempering module 10₁. The food mass is conveyed in the direction of the arrow R4 through the tempering module 10₁. The food mass is directed out from the tempering machine 100 through the outlet opening 36 of the tempering module 10₁ and can then be supplied by way of example to a coating device. The conveying direction R1, R2, R3, R4 of the food mass in the tempering modules 10₁, 10₂, 10₃, 10₄ runs in the tempering module 10₂, 10₃, 10₄ opposite the conveying direction R1, R2, R3, R4 of the previous tempering module 10₁, 10₂, 10₃, 10₄. The conveying direction thus changes in the tempering modules 10₁, 10₂, 10₃, 10₄. The food mass is consequently conveyed in meander fashion through the tempering

machine 100.

Fig. 10 shows an enlarged view of the detail X in Fig. 9.

5 Fig. 10 shows how adjacent tempering modules, here the tempering modules 10_1 and 10_2 , are coupled to one another via the connecting channel 104. For this, the connecting channel 104 can be connected to the second connecting flanges 26 of the tempering modules 10_1 and 10_2 . In particular the connecting channel 104
10 can be screwed to the second connecting flanges 26 of the tempering modules 10_1 and 10_2 . The connecting channel 104 thus couples the outlet and inlet openings 38 to the second connecting flanges 26 of the tempering modules 10_1 and 10_2 to one another, in order to be able to guide the food mass from one tempering
15 module 10_2 to the next tempering module 10_1 .

Fig. 11 shows diagrammatically the principle of the temperature control: this shows the arrangement of the tempering modules 10_1 to 10_4 which are each connected to one another via a
20 connecting channel 104. The flow direction of the food mass is indicated by arrows within the tempering modules 10_1 to 10_4 . The food mass enters into the tempering module 10_4 through the inlet opening 36. The entire tempering module 10_4 and approximately the first third of the tempering module 10_3 following in the
25 material flow direction form a decrystallization stage 118 which is supplied with tempering fluid via a water tempering circuit 120 with an inlet pipe 122, a connecting pipe 124 between the tempering modules 10_4 and 10_3 as well as an outlet pipe 126. This decrystallization stage 118 is separated from a following
30 first cooling stage 128 via a separating element 44_1 . The first cooling stage 128 extends approximately over the following two thirds of the tempering module 10_3 and the following adjoining downstream two thirds of the tempering module 10_2 . This first cooling stage 128 is supplied with tempering fluid with a water
35 tempering circuit 130 with an inlet pipe 132, a connecting pipe 134 between the tempering modules 10_3 and 10_2 as well as an outlet pipe 136. A second cooling stage 138 adjoins the first cooling stage 128 downstream in the material flow and separated

by a further separating element 44₂. The second cooling stage 138 extends approximately over the last following downstream tempering module 10₂ and the adjoining downstream two thirds of the tempering module 10₁. This second cooling stage 138 is also
5 supplied with tempering fluid with a water tempering circuit 140 with an inlet pipe 142, a connecting pipe 144 between the tempering modules 10₂ and 10₁, as well as an outlet pipe 146. A warming stage 148 adjoins the second cooling stage 138 downstream in the material flow, separated by a further
10 separating element 44₃. The warming stage 148 extends approximately over the last following third of the tempering module 10₁. This warming stage 148 is also supplied with tempering fluid with a water tempering circuit 150 with an inlet pipe 152 and an outlet pipe 154.

15 Finally several temperature and pressure sensors 156 are provided to detect the temperature and pressure of the food mass.

20 This structure of several tempering modules in series with corresponding water tempering circuits allows a targeted temperature control for the food mass for preparation and processing. A temperature gradient arises which can be described as follows:

25 Temperature stages:

tDS = Temperature in the decrystallization stage

30 tK1 = Temperature in the cooling stage 1

tK2 = Temperature in the cooling stage 2

tAW = Temperature in the warming stage

35 Temperature gradient between the decrystallization stage and first cooling stage:

$$\Delta t_1 = t_{DS} - t_{K1}$$

Temperature gradient between first and second cooling stage:

5
$$\Delta t_2 = t_{K1} - t_{K2}$$

Temperature gradient between second cooling stage and warming stage:

10
$$\Delta t_3 = t_{K2} - t_{AW}$$

Overall temperature gradient:

15
$$\Delta t_{\text{gesamt}} = \Delta t_1 + \Delta t_2 + \Delta t_3$$

This temperature gradient can be adjusted variably in its profile and in its overall amount and adapted to the processed food mass according to the loading of the decrystallization stage, the individual cooling stages as well as the warming stage with tempering fluid set to a desired temperature.

20

It is evident that the division can be configured differently. Separating elements can be removed or added in order to provide additional water tempering circuits or to remove individual water tempering circuits. Also, the separating elements can be changed, for example to make the decrystallization stage, individual cooling stages or the warming stage shorter or longer. The invention offers overall a variable temperature control for the food mass.

25

30

The tempering module described above, as a result of its tempering tube designed as one fixedly connected structural group, enables a rapid and simple cleaning. The tempering module according to the invention thus meets high hygienic standards.

Patentkrav

1. Tempereringsmodul (10) til en tempereringsmaskine (100) til temperering af en levnedsmiddelmasse med
5 - i det mindste en snekke (14) og
- i det mindste et tempereringsrør (12), i hvilket snekken (14) kan indsættes, hvor tempereringsrøret (12) og snekken (14) mellem sig fastlægger en transportkanal (16) for levnedsmiddelmassen, hvor tempereringsrøret (12) omfatter i det
10 mindste et indre rør (18) og i det mindste et ydre rør (20), hvor det indre rør (18) og det ydre rør (20) mellem sig fastlægger i det mindste et tempereringskammer (22), kendetegnet ved, at det indre rør (18) og det ydre rør (20) er forbundet varigt fast med hinanden sådan, at tempereringsrøret
15 (12) er en udelt komponent uden løsbare sammenføjningssteder.
2. Tempereringsmodul (10) ifølge krav 1, hvor tempereringsrøret (12) har i det mindste en første tilslutningsflange (24) og i det mindste en anden
20 tilslutningsflange (26), hvilke tilslutningsflanger forbinder det indre rør (18) og det ydre rør (20) varigt fast med hinanden.
3. Tempereringsmodul (10) ifølge krav 2, hvor det indre rør (18), det ydre rør (20), den første
25 tilslutningsflange (24) og den anden tilslutningsflange (26) er forbundet stofsluttende med hinanden, især sammensvejset.
4. Tempereringsmodul (10) ifølge krav 2 eller 3, hvor den første tilslutningsflange (24) kan forbindes med i det
30 mindste et tilslutningsstykke (28) for en motor (30), hvor den anden tilslutningsflange (26) kan forbindes med i det mindste et lukkeelement (32), på hvilket den i det mindste ene snekke (14) er lejret, og som danner en ende af tempereringsmodulet (10), hvor lukkeelementet (32) med henblik på udtagning af
35 snekken (14) er forbundet aftageligt med den anden tilslutningsflange (26), hvor især motoren (30) via i det mindste en aksel (34) er koblet med snekken (14), hvor akslen (34) strækker sig gennem

tilslutningsstykket (28).

5. Tempereringsmodul (10) ifølge et af kravene 2 til 4,
hvor den første tilslutningsflange (24) og den anden
5 tilslutningsflange (26) hver især har i det mindste en
indledningsåbning (36, 38) til indledning af levnedsmiddelmassen
i transportkanalen (16) for levnedsmiddelmassen og/eller i det
mindste en udledningsåbning (36, 38) til udledning af
levnedsmiddelmassen fra transportkanalen (16) for
10 levnedsmiddelmassen.

6. Tempereringsmodul (10) ifølge et af kravene 1 til 5,
hvor tempereringskammeret (22) har en eller flere
tempereringskanaler, fortrinsvis i det mindste en første
15 tempereringskanal (40) og i det mindste en anden
tempereringskanal (42), hvilke tempereringskanaler er afskilt
via i det mindste et skilleelement (44) i det i det mindste ene
tempereringskammer (22).

20 7. Tempereringsmodul (10) ifølge krav 6,
hvor den første tempereringskanal (40) og den anden
tempereringskanal (42) strækker sig i det væsentlige
spiralformet gennem tempereringskammeret (22).

25 8. Tempereringsmodul (10) ifølge krav 6 eller 7,
hvor tempereringsrøret (12) har tilslutninger (46, 48, 50, 52),
via hvilke den første tempereringskanal (40) og den anden
tempereringskanal (42) kan kobles med et første
tempereringskredsløb og et andet tempereringskredsløb til
30 tilførsel af en tempereringsfluid, hvor især tempereringsrøret
(12) har i det mindste en tilslutning (54) til temperaturkontrol
af levnedsmiddelmassen i transportkanalen (16) for
levnedsmiddelmassen.

35 9. Tempereringsmaskine (100) til temperering af en
levnedsmiddelmasse med i det mindste et tempereringsmodul (10₁,
10₂, 10₃, 10₄) ifølge et af kravene 1 til 8.

10. Tempereringsmaskine (100) ifølge krav 9,
hvor tempereringsmaskinen har flere tempereringsmoduler (10₁,
10₂, 10₃, 10₄) ifølge et af kravene 1 til 9, hvor de enkelte
tempereringsmoduler (10₁, 10₂, 10₃, 10₄) hver især er koblet via
5 en forbindelseskanal (104) til transport af levnedsmiddelmassen
fra et tempereringsmodul (10₁, 10₂, 10₃, 10₄) til det
tempereringsmodul (10₁, 10₂, 10₃, 10₄), der ligger
massenedstrøms,
hvor især forbindelseskanalen (104) kobler en udledningsåbning
10 (36, 38) på et tempereringsmodul (10₁, 10₂, 10₃, 10₄) med en
indledningsåbning (36, 38) på det næste tempereringsmodul (10₁,
10₂, 10₃, 10₄).

11. Tempereringsmaskine (100) ifølge krav 9 eller 10,
15 hvor tempereringsmaskinen (100) har i det mindste et flytbart
eller stationært stativ (102), på hvilket det i det mindste ene
tempereringsmodul (10₁, 10₂, 10₃, 10₄) er anbragt, især
horisontalt.

20 12. Tempereringsmaskine ifølge et af kravene 9-11, hvor
tempereringsmaskinen er udformet til at være anbragt tilstødende
til en masseforrådsbeholder til lagring af levnedsmiddelmassen
og/eller til en anordning, der videreforarbejder
levnedsmiddelmassen, især en
25 levnedsmiddelmasse-overtrækningsmaskine eller/og en
levnedsmiddelmasse-dekorationsmaskine eller/og en
levnedsmiddelmasse-støbemaskine.

13. Fremgangsmåde til temperering af en levnedsmiddelmasse med
30 et tempereringsmodul (10) ifølge et af kravene 1 til 8, især med
en tempereringsmaskine ifølge et af kravene 9 til 12, hvorved
det i det mindste ene tempereringskammer (22) gennemstrømmes af
en tempereringsfluid, især vand, for at temperere
levnedsmiddelmassen i transportkanalen (16) for
35 levnedsmiddelmassen.

14. Fremgangsmåde ifølge krav 13, hvorved levnedsmiddelmassen
indføres i en første tempereringskanal, der danner et

dekrySTALLISERINGSTRIN for levnedsmiddelmassen, hvorved levnedsmiddelmassen yderligere føres fra den første tempereringskanal indirekte eller direkte ind i en anden tempereringskanal, der danner et køletrin, og hvorved 5 levnedsmiddelmassen føres fra den anden tempereringskanal ind i en tredje tempereringskanal, der danner et opvarmningstrin, hvorved især hver af tempereringskanalerne kan forsynes med tempereringsfluid via en separat tempereringsfluidkreds.

10 15. Fremgangsmåde ifølge krav 13 eller 14, hvorved der under styring af temperaturen og gennemstrømningen af den respektive tempereringsfluid i den tilhørende tempereringsfluidkreds eller/og under styring af levnedsmiddelmassens transporthastighed gennem den respektive tempereringskanal i 15 afstemning med den respektive tempereringskanals længde kan indstilles en forudbestemt opholdstid af levnedsmiddelmassen i den respektive tempereringskanal.

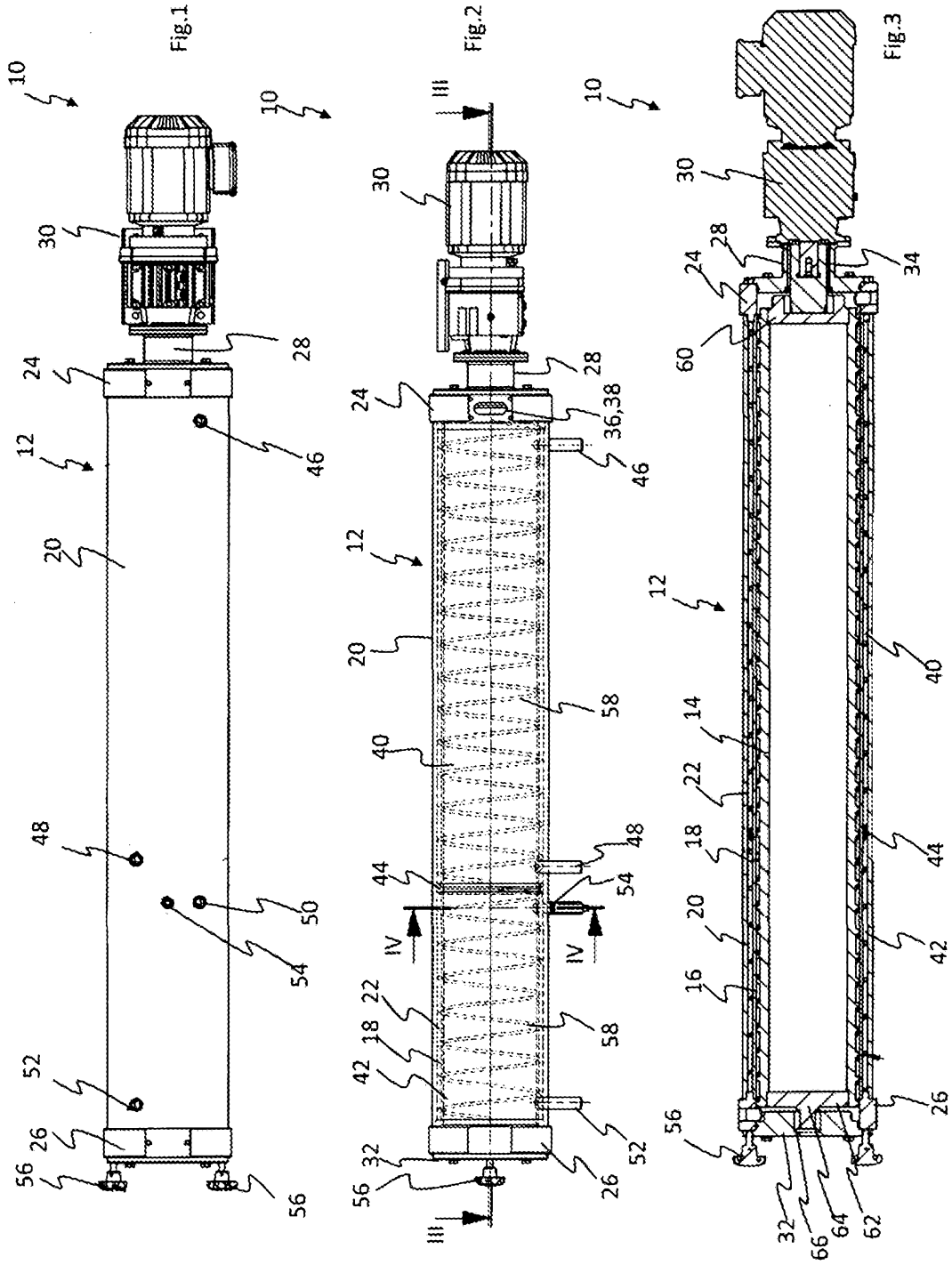

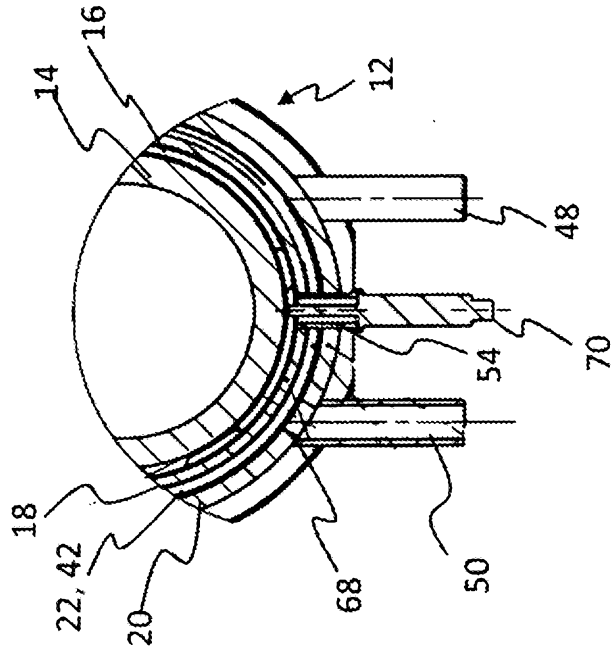

Fig.5

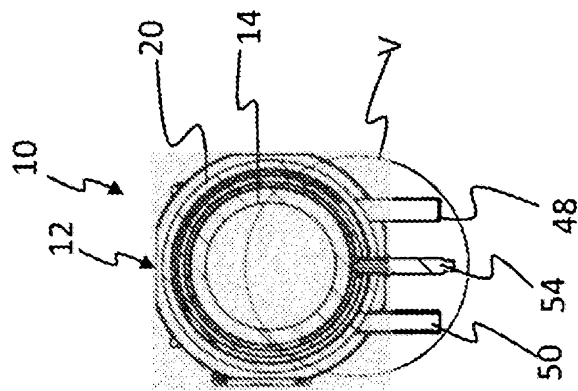

Fig.4

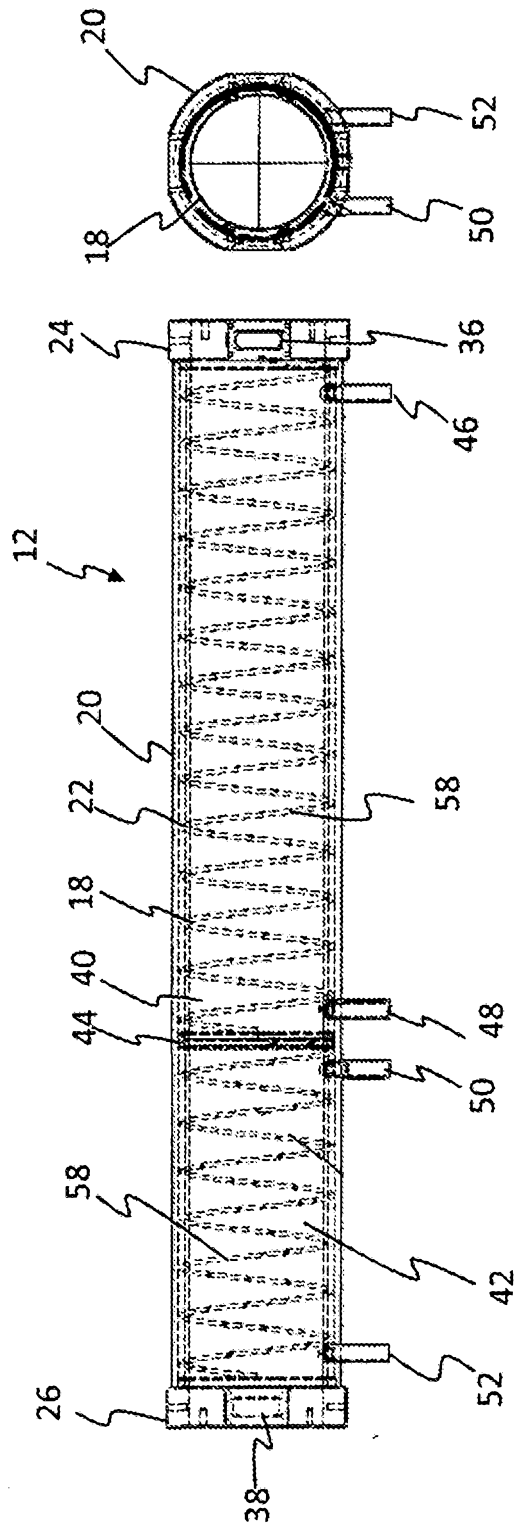
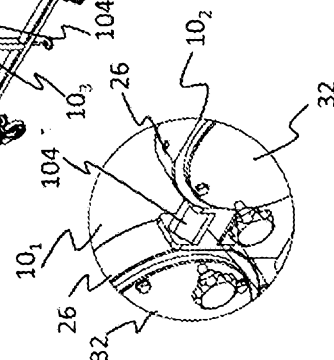
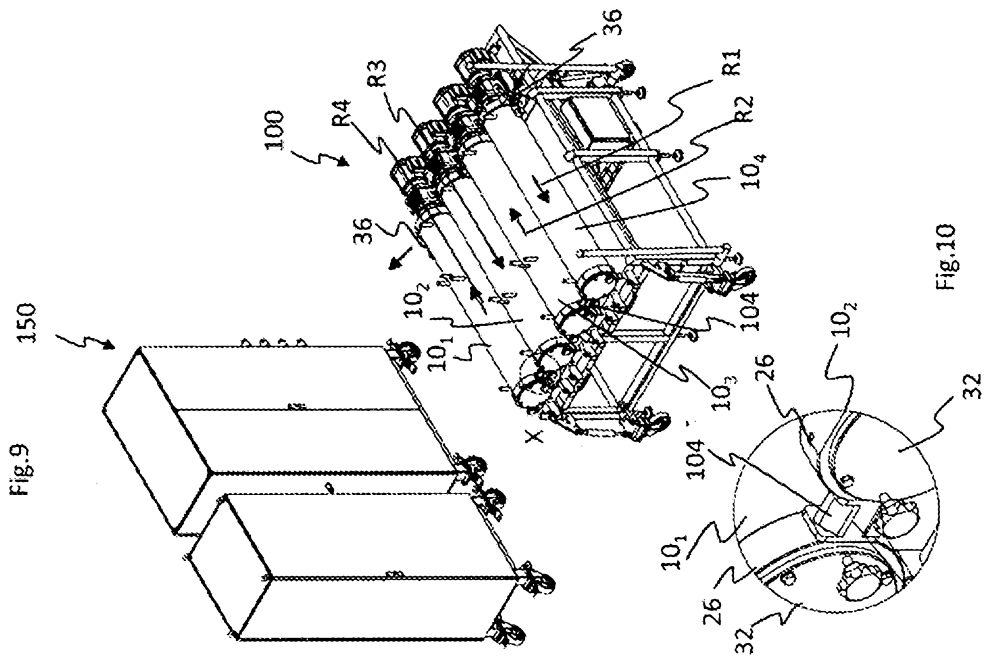
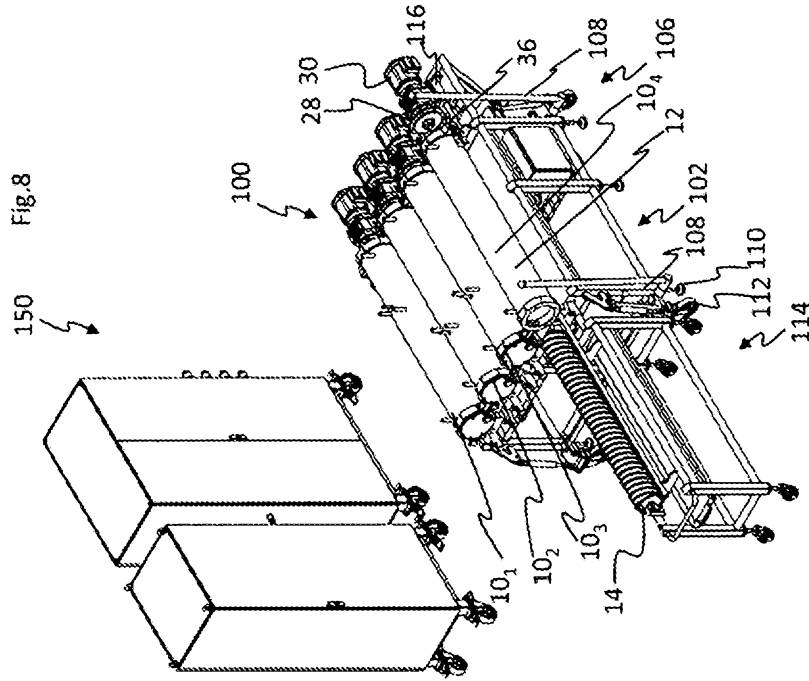

Fig.7

Fig.6



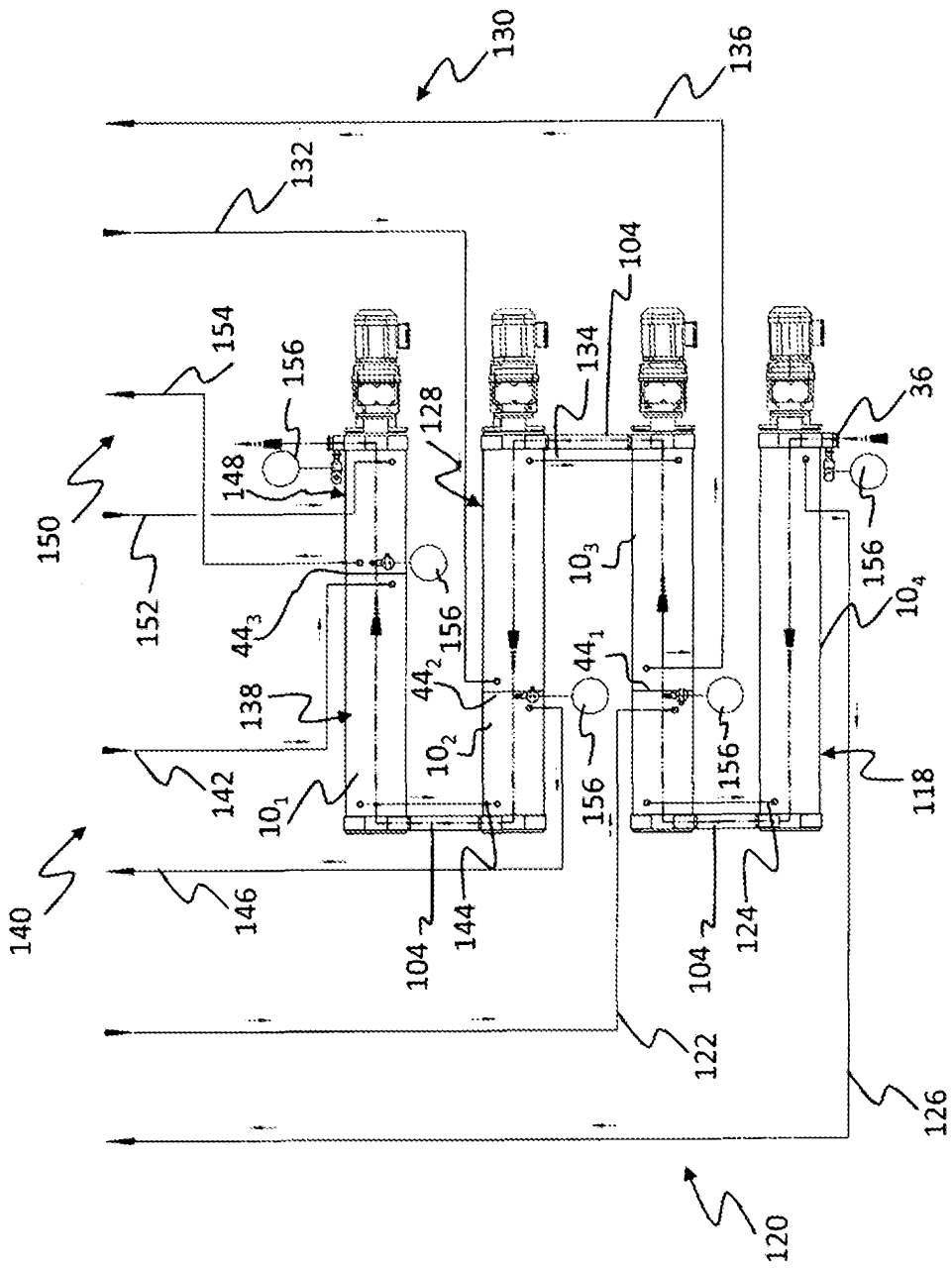

Fig.11

