



## INTERNATIONAL APPLICATION PUBLISHED UNDER THE PATENT COOPERATION TREATY (PCT)

<p>(51) International Patent Classification <sup>5</sup> : A01M 7/00, 9/00, B05B 7/06</p>	<p>A1</p>	<p>(11) International Publication Number: WO 93/17551 (43) International Publication Date: 16 September 1993 (16.09.93)</p>
<p>(21) International Application Number: PCT/AU93/00084 (22) International Filing Date: 2 March 1993 (02.03.93) (30) Priority data: PL 1194 5 March 1992 (05.03.92) AU (71)(72) Applicants and Inventors: BARLOW, Donald, Charles [AU/AU]; Coonoowrin Road, Glasshouse Mountains, QLD 4518 (AU). BICKLE, Trevor, Edward [AU/AU]; 7 Bruce Parade, Glasshouse Mountains, QLD 4518 (AU). (74) Agent: GARDNER, John, R., G.; P.O. Box 443, Mudgeeraba, QLD 4213 (AU).</p>		<p>(81) Designated States: AT, AU, BB, BG, BR, CA, CH, CZ, DE, DK, ES, FI, GB, HU, JP, KP, KR, LK, LU, MG, MN, MW, NL, NO, NZ, PL, PT, RO, RU, SD, SE, SK, UA, US, European patent (AT, BE, CH, DE, DK, ES, FR, GB, GR, IE, IT, LU, MC, NL, PT, SE), OAPI patent (BF, BJ, CF, CG, CI, CM, GA, GN, ML, MR, SN, TD, TG).</p> <p>Published With international search report. With amended claims.</p>
<p>(54) Title: SPRAYING APPARATUS</p>		
<p>(57) Abstract</p> <p>Spraying apparatus (10) for spraying trees with pesticides or other chemicals, the apparatus (10) including a frame (11) which supports a tank (14) for containing liquid to be sprayed. Supported on the frame (11) is a tower assembly (21) which includes a pair of planar faces (22) and (23) separated by vanes (24) which define air passages in the tower assembly (21) which communicate with the outlet of a blower (15). A number of spray outlet nozzles (47) are arranged along the tower assembly (21) in the outlets of the air passages so that air passing through the passages forces the spray from the nozzles outwardly into trees to be sprayed.</p>		

**FOR THE PURPOSES OF INFORMATION ONLY**

Codes used to identify States party to the PCT on the front pages of pamphlets publishing international applications under the PCT.

AT	Austria	FR	France	MR	Mauritania
AU	Australia	GA	Gabon	MW	Malawi
BB	Barbados	GB	United Kingdom	NL	Netherlands
BE	Belgium	GN	Guinea	NO	Norway
BF	Burkina Faso	GR	Greece	NZ	New Zealand
BG	Bulgaria	HU	Hungary	PL	Poland
BJ	Benin	IE	Ireland	PT	Portugal
BR	Brazil	IT	Italy	RO	Romania
CA	Canada	JP	Japan	RU	Russian Federation
CF	Central African Republic	KP	Democratic People's Republic of Korea	SD	Sudan
CG	Congo	KR	Republic of Korea	SE	Sweden
CH	Switzerland	KZ	Kazakhstan	SK	Slovak Republic
CI	Côte d'Ivoire	LI	Liechtenstein	SN	Senegal
CM	Cameroon	LK	Sri Lanka	SU	Soviet Union
CS	Czechoslovakia	LU	Luxembourg	TD	Chad
CZ	Czech Republic	MC	Monaco	TG	Togo
DE	Germany	MG	Madagascar	UA	Ukraine
DK	Denmark	ML	Mali	US	United States of America
ES	Spain	MN	Mongolia	VN	Viet Nam
FI	Finland				

SPRAYING APPARATUSTechnical Field

THIS INVENTION relates to spraying apparatus particularly suited for the application of pesticides, fungicides or other chemicals to growing crops, such as trees or plants.

Background Art

A number of different forms of spraying equipment are presently available for applying pesticide or fungicide to growing plants. In orchard situations where plants such as fruit or nut trees are arranged in rows, the spraying equipment which is employed generally comprises air blast sprayers which are in the form of a mobile chassis which supports a liquid tank for carrying a pesticide and/or fungicide, a driven air fan, and a series of radially located nozzles connected to the tank through which pesticide or fungicide is directed, the air blast generated by the fan causing the sprayed liquid to be directed radially outwardly towards the trees as the sprayer is moved along the rows. Such air blast sprayers may be single sided to spray a row on one side only or double sided to spray a pair of adjacent rows, however, in either configuration, such sprayers have not proved to be particularly efficient. Tests have shown that the coverage achieved is not particularly effective so that regular and repeated applications of pesticide or fungicide are required resulting in excessive chemical usage. Additionally the configuration of such air blast sprayers is such that a large amount of spray drift occurs thereby creating an environmental hazard. Spray penetration into the plants is also limited, particularly in trees such as macadamia nut trees where the foliage tends to block air entry and thus the fungicide or pesticide, from reaching the fruit or nuts.

Summary of the Invention

The present invention aims to provide spraying apparatus which will operate efficiently and ensure reliable application of pesticide, fungicides or other chemicals to trees or other plants. The present invention also aims to

provide apparatus which more effectively applies the sprayed chemical to trees or other plants, thereby permitting an increase ground speed of operation to reduce the time involved in chemical application. The present invention further aims  
5 to provide spraying apparatus which substantially reduces chemical drift to thereby reduce the environmental impact of spraying, and chemical usage.

The present invention thus provides in a first aspect spraying apparatus including a mobile frame, air blast  
10 generating means supported on said frame, liquid storage means on said frame for carrying a liquid to be sprayed, a plurality of ducts opening at one end to one side of said frame to define air outlets and communicating at their other end with said air  
blast generating means whereby air from said air blast  
15 generating means may pass therealong, and a plurality of nozzles located at or adjacent the respective said outlets of said ducts and communicating with said liquid storage means such that liquid sprayed from said nozzles is forced outwardly by air passing along said ducts and through said outlets.

20 The present invention in a second aspect provides spray distribution apparatus adapted to be mounted to an air blast sprayer of the type including a mobile frame, air blast generating means on said frame, and liquid storage means on said frame for carrying a liquid to be sprayed, said spray  
25 distribution apparatus including a plurality of ducts opening at one end in use to one side of said mobile frame to define air outlets and adapted to communicate at their other end with said air blast generating means whereby air from said air blast generating means may pass therealong and a plurality of nozzles  
30 located at or adjacent the respective said outlets of said ducts and adapted to communicate with said liquid storage means such that liquid sprayed from said nozzles is forced outwardly by air passing along said ducts and through said outlets.

35 Preferably the ducts comprise a plurality of side-by-side passageways and the duct outlets are arranged one above the other. Most preferably the ducts are defined in an upright tower assembly which communicates at its lower end with the air

blast generating means. Preferably, such ducts are defined between guide fins or vanes. Preferably the fins or vanes are disposed between opposite planar members or faces of the tower assembly to form an integral assembly of ducts.

5 For the purposes of storage the tower may be formed in two hingedly interconnected parts, one part being mounted to, or adjacent the air blast generating means, and the other part being hingedly mounted to the first part and being movable between an upright operative position in alignment with the  
10 first part and a folded inoperative position. Suitably, in its inoperative position, the other part of the tower is disposed in a generally horizontal attitude. Preferable the other part of the tower is adapted to be moved between its positions by an actuator suitably an hydraulic ram.

15 The ducts may incorporate means to vary air flow therealong so that varying air flow through the outlets can be achieved. Such means may comprise pivotal vane members. Pivotal vane members may also be employed to vary the direction of air flow and thus spray from the outlets.

20 The liquid nozzles are also preferably adjustable in orientation to vary the direction of spray outlet. The nozzles may also be pivotally moved to a fully off position to prevent fluid outlet from a particular nozzle. Preferably the nozzles communicate with liquid in the liquid storage means via a pump.

25 The apparatus is most suitably adapted to be coupled to a prime mover such as a tractor which through its PTO unit may provide power to drive the air blast generating means and the liquid pump. The air blast generating means preferably is in the form of a fan including a rotatable fan blade supported  
30 in a shroud.

#### Brief Description of the Drawings

In order that the invention may be more readily understood and put into practical effect, reference will now be made to the accompanying drawings which illustrate a  
35 preferred embodiment of the invention and wherein :-

Fig. 1 is a perspective view from the front of spraying apparatus according to the present invention in

an operative attitude;

Fig. 2 is a rear view of the apparatus of Fig. 1 in use;

5 Fig. 3 illustrates the spraying apparatus in a folded attitude;

Fig. 4 is a longitudinal sectional view showing the configuration of the air ducts;

Figs. 5, 6 and 7 are enlarged views of the regions A, B and C of Fig. 4; and

10 Fig. 8 is an enlarged side view showing details of the liquid nozzles and air ducts.

#### Detailed Description of the Preferred Embodiment

Referring to the drawings and initially to Fig. 1, there is illustrated spraying apparatus 10 according to the present invention including a mobile frame 11 supported on wheels 12 and adapted to be coupled at 13 to a prime mover, such as a towing tractor. Supported on the frame 11 is a tank 14 for carrying liquid to be sprayed, such as a pesticide, fungicide or other chemical. Arranged at the rear of the tank 14 is a blower 15 (see Figs. 2,3 and 8 ) which includes a fan blade assembly 16 located within an annular shroud 17 and adapted to be driven in this embodiment via a shaft 18 coupled to the power take-off of the prime mover. For safety purposes, a grill or mesh 19 is located over the suction inlet of the blower 15. The blower 15 additionally includes an annular outlet 20 through which air is directed radially outwardly as indicated by the arrows in Figs. 4 and 8 except at the lower side where the outlet is blocked so that air is not directed downwardly. The arrangement of tank 14, blower 15 and frame 11 as described above comprises a conventional air blast sprayer wherein a plurality of nozzles are normally arranged in a circular array about the blower outlet 20. In this instance, however, the nozzles in the blower outlet 20 are eliminated.

35 Mounted on the frame 11 adjacent to the outlet 20 of the blower 15 is a hollow tower assembly 21 which in the embodiment illustrated is in the form of spaced apart planar

faces 22 and 23 separated and joined by a series of vanes shown generally at 24. In this embodiment the tower 21 is formed in upper and lower parts 25 and 26 respectively, the tower part 26 being fixedly mounted to the frame 11 about the blower outlet 20 and communicating therewith and the upper part 25 being hingedly connected through a transverse hinge at 27 to the lower part 26 for movement between the upright position shown in Figs. 1 and 2 and the folded position shown in Fig. 3. The upper tower part 25 is moved between its respective positions by means of a hydraulic ram 28 connected between supporting frames 29 and 30 for the upper and lower tower parts 25 and 26 respectively. In its lowered position, the tower part 25 is supported on a saddle 31 mounted to the frame 11. The supporting frame 30 for the tower part 26 also incorporates bracing members 32 to brace the tower part 26 to the frame 11 in its upright attitude.

As shown more clearly in Figs. 4 to 7 the vanes 24 extend from one side 33 of the tower assembly 21 to positions adjacent the outlet 20 of the blower 15 so as to define therebetween and with the faces 22 and 23 a plurality of passages 34 which open at their upper ends to define outlets 35 arranged one above the other. As shown, the vanes 24 comprise a first set of vanes which extend along the upper part 26 of the tower assembly and into the lower part 26 adjacent the outlet 20 of the blower 15, the first set of vanes being defined by upper vane members 36 in the upper tower part 25 and aligned vanes members 37 in the lower part 26.

A second set of vanes are disposed between the first set of vanes defined by vane members 36 and 37 and comprise first vane members 38 extending from the outlets 35 to the hinge connection 27 whereat they are aligned with adjustable vane members 39 pivotally mounted at 40 between the faces 22 and 23. The pivotal mounting for each vane member 39 may simply comprise a bolt 41 extending between the faces 22 and 23 with adjustment of the vane members 39 achieved by loosening the bolt 41 and pivoting the member 39 by hand between the positions shown in dotted outline in Fig. 5 to a desired

position whereafter the bolt 41 is tightened to maintain the vane member 39 in its adjusted position. This arrangement enables the air to be directed along the passages 34 as desired and adjustment to enable even air flow in adjacent passages 34  
5 if required.

At the lower end of the tower assembly 21 in the tower part 26 and on the outlet side 33 thereof, further vanes 42 are provided. These vanes 42 are pivotally mounted by means of a through bolt 43 at their inner ends and have a number of  
10 set positions determined by opposed sets of apertures 44 in the faces 22 and 23 which may receive securing bolts 45 which pass through flanges 46 formed on opposite sides of the vanes 42 (see also Fig. 8). For adjustment, the bolts 45 are removed, the vanes 42 repositioned by pivoting and the bolts 45 rein-  
15 serted through the flanges 46 and a new set of apertures 44.

Disposed in the outlets 35 are respective adjustable jets or nozzles 47 which communicate with respective manifolds 48 in the upper tower part 26 and manifolds 49 in the lower tower part 25 arranged on the outside of the tower assembly 21  
20 and adjacent the face 23. The manifolds 48 and 49 are connected by respective supply pipes 50 to a pump 51 mounted on the frame 11 and connected to the tank 14. The pump 51 is also arranged to be driven through the power take off unit of the prime mover. The pipes 50 may incorporate valves 52 to  
25 control flow of liquid therealong from the tank 14.

The jets or nozzles 47 are of a known type and may be pivotally adjusted to vary the output angle of spray. Additionally, the jets or nozzles 47 may be pivoted to a position to fully close off communication with their associated  
30 manifolds. Thus selected patterns of spray direction can be achieved.

In use, the nozzles 47 and vane members 46 are adjusted to suit the trees to be sprayed so as to ensure the spray from the nozzles 47 is directed as desired. The tower  
35 assembly 21 is moved to a raised position and the apparatus 10 conveyed along a row of trees 53. Upon operation of the blower 15 and pump 40, the chemical will be sprayed from the nozzles

47 and directed outwardly at angles previously set. The air blast induced by the blower 15 flows along respective passages 34 to exit through the outlets 35 causing the mist or spray generated in the nozzles 47 to be forced into the trees 53.

5 The apparatus 10 will be driven along one row to spray the trees in that row and on its return can spray the trees in the adjacent row. At any time, the vanes 46 may be adjusted to vary air outlet direction at the lower portion of the tower assembly 21 so that say spray can be directed to the underside

10 of the trees whilst the nozzles 47 may also be adjusted to vary spray outlet direction.

It has been found that the spraying apparatus of the invention is particularly effective in ensuring effective penetration of trees and treatment of nuts or fruit. Increased

15 penetration also is accompanied by increased speed of operation so that less time is spent on spraying and additionally, reduced chemical usage results.

The tower assembly 21 is preferably constructed of a non corrosive material such as aluminium or galvanized sheet

20 material and the faces 22 and 23 formed of interconnected sheets. Alternatively the tower assembly 21 may be constructed of plastics. The various vane members preferably are of a form having right angled flanges on opposite sides which permits them to be connected to the faces 22 and 23 by rivets. The

25 spraying apparatus 10 described above includes components of a standard air blast sprayer. The tower assembly 21 however, may be mounted to air blast sprayers of other forms or alternatively the apparatus may include purpose constructed components for use in association with the tower assembly 21.

30 Thus the blower may be a separate driven device as may be the pump supply of chemicals to the nozzles 47.

Whilst the above has been given by way of illustrative embodiment of the invention, all such modifications and variations thereto as would be apparent to

35 persons skilled in the art are deemed to fall within the broad scope and ambit of the invention as herein defined in the appended claims.

CLAIMS

1. Spraying apparatus including a mobile frame, air blast generating means supported on said frame, liquid storage means on said frame for carrying a liquid to be sprayed, a  
5 plurality of ducts opening at one end to one side of said frame to define air outlets and communicating at their other end with said air blast generating means whereby air from said air blast generating means may pass therealong, and a plurality of  
10 nozzles located at the respective said outlets of said ducts and communicating with said liquid storage means such that liquid sprayed from said nozzles is forced outwardly by air passing along said ducts and through said outlets.
2. Apparatus according to Claim 1, wherein said ducts  
15 comprise a plurality of side-by-side passageways and wherein said duct outlets are arranged one above the other.
3. Apparatus according to Claim 1 or Claim 2, wherein said ducts are defined in an upright tower assembly which  
20 communicates at its lower end with said air blast generating means.
4. Apparatus according to Claim 3, wherein said ducts are defined between a plurality of fins or vanes within said  
25 tower assembly.
5. Apparatus according to Claim 4, wherein said tower assembly includes opposite planar faces and wherein said fins or vanes are disposed between said faces.  
30
6. Apparatus according to Claim 3, wherein said tower assembly is formed by two hingedly interconnected parts, one said part being mounted to, or adjacent said air blast generating means, and the other said part being hingedly  
35 mounted to the first part.

7. Apparatus according to Claim 6, wherein said other part of said tower assembly is movable between an upright operative position in alignment with the first part and a folded inoperative position.
- 5
8. Apparatus according to Claim 7, wherein said first part is adapted to be moved between its positions by an actuator.
9. Apparatus according to Claim 7, wherein said first  
10 part of said tower assembly in said inoperative position is arranged substantially horizontally.
10. Apparatus according to Claim 1, wherein said ducts incorporate means to vary air flow therealong so that varying  
15 air flow through the outlets can be achieved.
11. Apparatus according to Claim 9, wherein said varying means comprise pivotal vane members.
- 20 12. Apparatus according to Claim 4, wherein some of said fins or vanes are adjustable adjacent said outlets to vary the direction of air flow therefrom.
13. Apparatus according to Claim 1, wherein said nozzles  
25 are adjustable to vary the direction of spray therefrom.
14. Spray distribution apparatus adapted to be mounted to an air blast sprayer of the type including a mobile frame, air blast generating means on said frame, and liquid storage  
30 means on said frame for carrying a liquid to be sprayed, said spray distribution apparatus including a plurality of ducts opening at one end in use to one side of said mobile frame to define air outlets and adapted to communicate at their other end with said air blast generating means whereby air from said  
35 air blast generating means may pass therealong, and a plurality

of nozzles located at or adjacent the respective said outlets  
of said ducts and adapted to communicate with said liquid  
storage means such that liquid sprayed from said nozzles is  
forced outwardly by air passing along said ducts and through  
5 said outlets.

10

15

20

25

30

35

## AMENDED CLAIMS

[received by the International Bureau on 17 August 1993 (17.08.93); original claims 1, 3, 6, 10, 12 and 14 amended; new claims 15-17 added; other claims unchanged (3 pages)]

1. Spraying apparatus including a mobile frame, air blast generating means supported on said frame, said air blast generating means having an outlet through which air  
5 may pass in a generally radial direction, liquid storage means on said frame for carrying a liquid to be sprayed, a duct assembly supported on said frame adjacent said air outlet of said air blast generating means, said duct assembly including a plurality of ducts, said ducts opening  
10 at one end to one side of said mobile frame to define a plurality of outlets and communicating at their other end with said air outlet whereby air from said air blast generating means may pass therealong, and a plurality of nozzles located at or adjacent the respective said outlets  
15 of said ducts and communicating with said liquid storage means such that liquid sprayed from said nozzles is forced outwardly by air passing along said ducts and through said outlets.

20 2. Apparatus according to Claim 1 wherein said ducts comprise a plurality of side-by-side passageways and wherein said duct outlets are arranged one above the other.

3. Apparatus according to Claim 1 or Claim 2 wherein  
25 said ducts are defined in an upright tower assembly which is mounted at its lower end to or adjacent said air outlet of said air blast generating means.

4. Apparatus according to Claim 3 wherein said ducts  
30 are defined between a plurality of fins or vanes within said tower assembly.

5. Apparatus according to Claim 4 wherein said tower  
assembly includes opposite planar faces and wherein said  
35 fins or vanes are disposed between said faces.

6. Apparatus according to Claim 3 wherein said tower

assembly is formed by two hingedly interconnected parts, one said part being mounted about said air blast generating means, and the other said part being hingedly mounted to the first part.

5

7. Apparatus according to Claim 6 wherein said other part of said tower assembly is movable between an upright operative position in alignment with the first part and a folded inoperative position.

10

8. Apparatus according to Claim 7 wherein said first part is adapted to be moved between its positions by an actuator.

15

9. Apparatus according to Claim 7, wherein said first part of said tower assembly in said inoperative position is arranged substantially horizontally.

20

10. Apparatus according to Claim 1 wherein said ducts incorporate means to vary air flow therealong so that air flow through respective said duct outlets can be adjusted.

25

11. Apparatus according to Claim 9 wherein said varying means comprise pivotal vane members.

30

12. Apparatus according to Claim 4, wherein some of said fins or vanes are adjustable adjacent said duct outlets to vary the direction of air flow therefrom.

30

13. Apparatus according to Claim, wherein said nozzles are adjustable to vary the direction of spray therefrom.

35

14. Spray distribution apparatus adapted to be mounted to an air blast sprayer of the type including air blast generating means, said air blast generating means

having an outlet through which air may flow, and liquid storage means for carrying a liquid to be sprayed, said spray distribution apparatus including a duct assembly defining a plurality of ducts, said duct assembly being  
5 adapted to be mounted at one end to or adjacent said air outlet of said air blast generating means whereby air flowing outwardly from said air outlet may pass into one end of said ducts and flow therealong, said ducts being open at their other end to one side of said apparatus to  
10 define a plurality of outlets, and a plurality of nozzles located at or adjacent the respective said outlets of said ducts and adapted to communicate with said liquid storage means such that liquid sprayed from said nozzles is forced outwardly by air passing along said ducts and through said  
15 outlets.

15. Spray distribution apparatus according to Claim 14, wherein said duct assembly comprises a normally upright tower assembly adapted to be mounted at its lower end about  
20 said air outlet of said air blast generating means.

16. Spray distribution apparatus according to Claim 15, wherein said ducts are defined between a plurality of fins or vanes within said tower assembly.

25

17. Spray distribution apparatus according to Claim 16, wherein said tower assembly includes first and second spaced apart planar faces between which said fins or vanes are located, said faces being disposed on opposite sides of  
30 said air outlet so as to capture air passing therethrough.

35

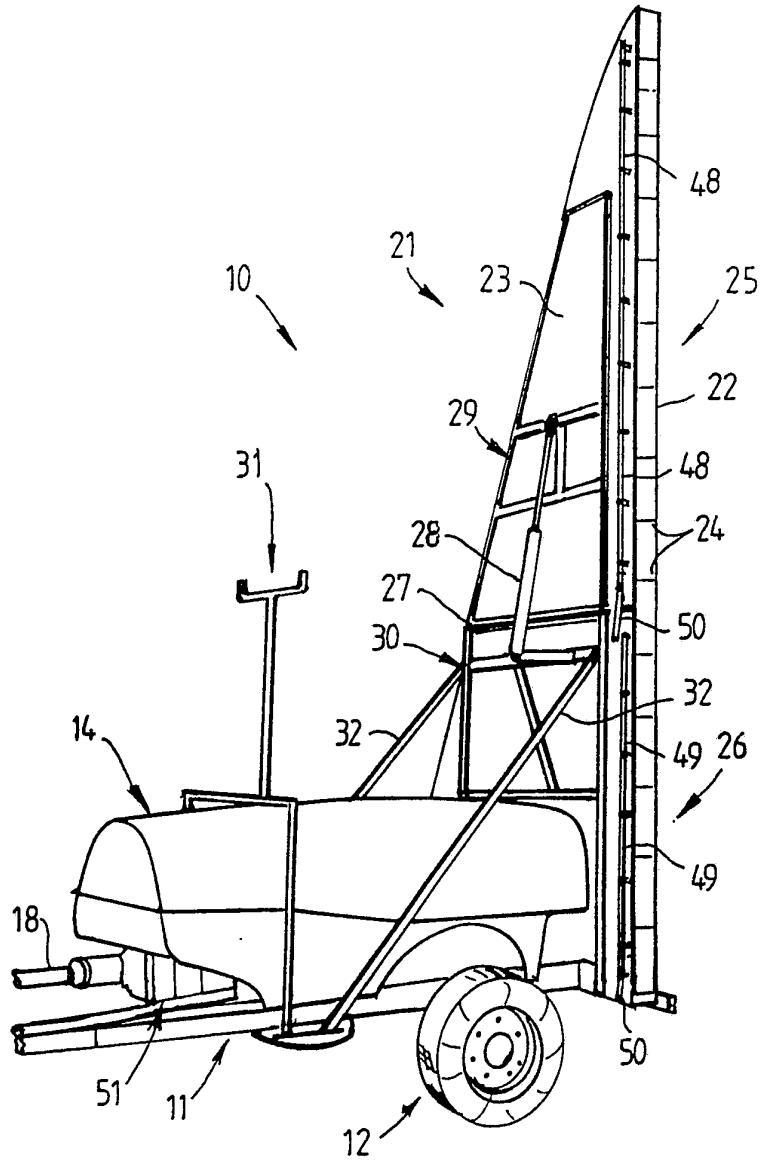

FIG.1

2/5

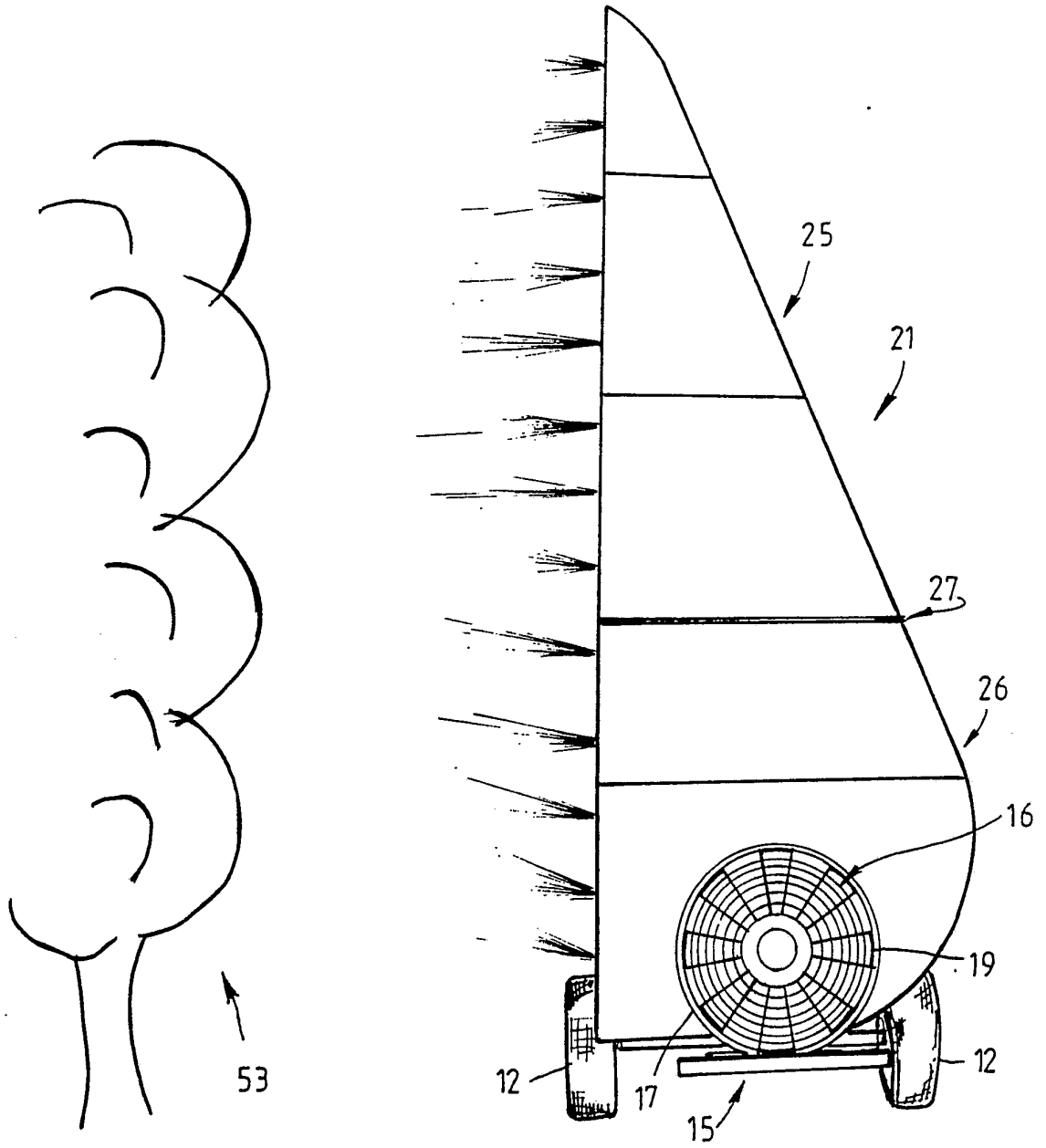
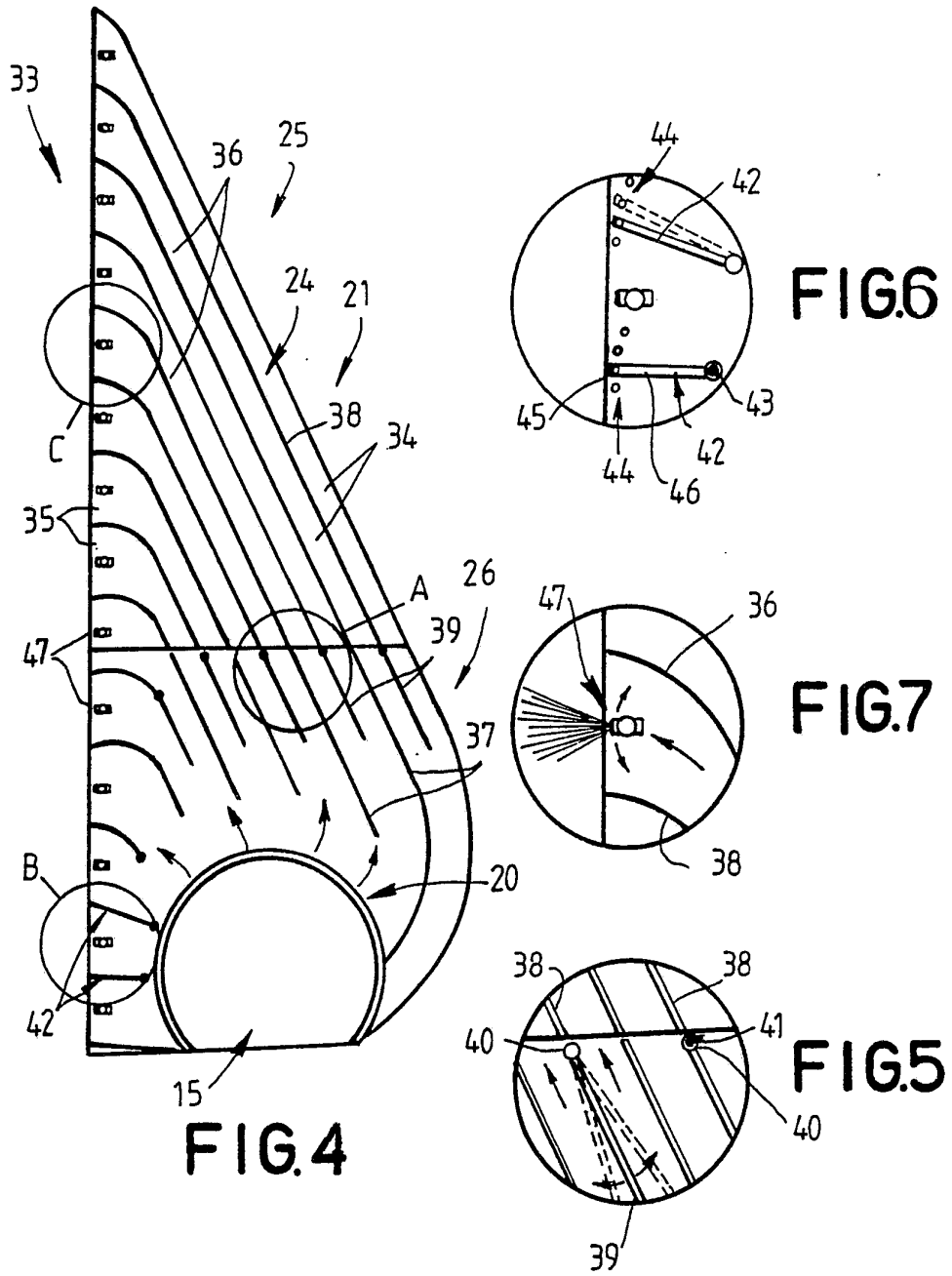

FIG.2





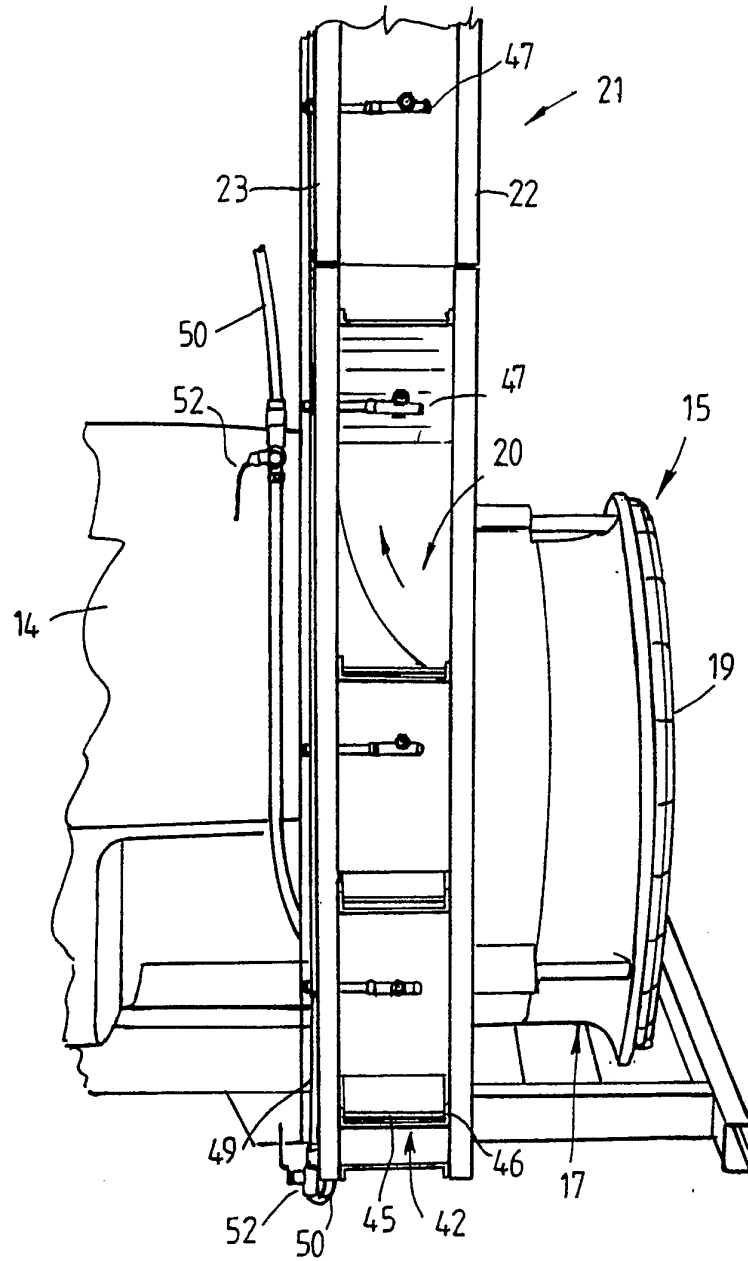
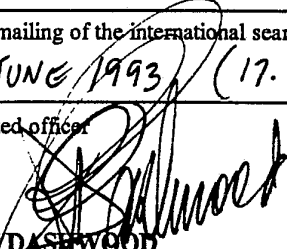

FIG.8

<b>A. CLASSIFICATION OF SUBJECT MATTER</b> Int. Cl. <sup>5</sup> A01M 07/00, 09/00, B05B 07/06  According to International Patent Classification (IPC) or to both national classification and IPC																						
<b>B. FIELDS SEARCHED</b>  Minimum documentation searched (classification system followed by classification symbols) IPC A01M 07/00, B05B 07/06  Documentation searched other than minimum documentation to the extent that such documents are included in the fields searched AU : IPC as above  Electronic data base consulted during the international search (name of data base, and where practicable, search terms used)																						
<b>C. DOCUMENTS CONSIDERED TO BE RELEVANT</b>																						
Category*	Citation of document, with indication, where appropriate, of the relevant passages	Relevant to Claim No.																				
X Y	AU,B, 7126/55 (201728) (A/S R SIGVARDT) 25 August 1955 (22.08.55) Pages 1-3, Claims 1 and 16, Figure 1	1,2,4,13,14 3,5-9																				
X	US,A, 3625426 (SWANSON) 7 December 1971 (07.12.71) Column 1, Figure 1, Claims 1-6	1,11,14																				
X	US,A, 3655130 (PATRICK) 11 April 1972 (11.04.72) Column 2 lines 1-49, Figures 1-3, Claims 1,10	1,13,14																				
<input checked="" type="checkbox"/> Further documents are listed in the continuation of Box C. <input checked="" type="checkbox"/> See patent family annex.																						
* Special categories of cited documents : <table border="0"> <tr> <td>"A"</td> <td>document defining the general state of the art which is not considered to be of particular relevance</td> <td>"T"</td> <td>later document published after the international filing date or priority date and not in conflict with the application but cited to understand the principle or theory underlying the invention</td> </tr> <tr> <td>"E"</td> <td>earlier document but published on or after the international filing date</td> <td>"X"</td> <td>document of particular relevance; the claimed invention cannot be considered novel or cannot be considered to involve an inventive step when the document is taken alone</td> </tr> <tr> <td>"L"</td> <td>document which may throw doubts on priority claim(s) or which is cited to establish the publication date of another citation or other special reason (as specified)</td> <td>"Y"</td> <td>document of particular relevance; the claimed invention cannot be considered to involve an inventive step when the document is combined with one or more other such documents, such combination being obvious to a person skilled in the art</td> </tr> <tr> <td>"O"</td> <td>document referring to an oral disclosure, use, exhibition or other means</td> <td>"&amp;"</td> <td>document member of the same patent family</td> </tr> <tr> <td>"P"</td> <td>document published prior to the international filing date but later than the priority date claimed</td> <td></td> <td></td> </tr> </table>			"A"	document defining the general state of the art which is not considered to be of particular relevance	"T"	later document published after the international filing date or priority date and not in conflict with the application but cited to understand the principle or theory underlying the invention	"E"	earlier document but published on or after the international filing date	"X"	document of particular relevance; the claimed invention cannot be considered novel or cannot be considered to involve an inventive step when the document is taken alone	"L"	document which may throw doubts on priority claim(s) or which is cited to establish the publication date of another citation or other special reason (as specified)	"Y"	document of particular relevance; the claimed invention cannot be considered to involve an inventive step when the document is combined with one or more other such documents, such combination being obvious to a person skilled in the art	"O"	document referring to an oral disclosure, use, exhibition or other means	"&"	document member of the same patent family	"P"	document published prior to the international filing date but later than the priority date claimed		
"A"	document defining the general state of the art which is not considered to be of particular relevance	"T"	later document published after the international filing date or priority date and not in conflict with the application but cited to understand the principle or theory underlying the invention																			
"E"	earlier document but published on or after the international filing date	"X"	document of particular relevance; the claimed invention cannot be considered novel or cannot be considered to involve an inventive step when the document is taken alone																			
"L"	document which may throw doubts on priority claim(s) or which is cited to establish the publication date of another citation or other special reason (as specified)	"Y"	document of particular relevance; the claimed invention cannot be considered to involve an inventive step when the document is combined with one or more other such documents, such combination being obvious to a person skilled in the art																			
"O"	document referring to an oral disclosure, use, exhibition or other means	"&"	document member of the same patent family																			
"P"	document published prior to the international filing date but later than the priority date claimed																					
Date of the actual completion of the international search 1 June 1993 (01.06.93)		Date of mailing of the international search report 17 JUNE 1993 (17.06.93)																				
Name and mailing address of the ISA/AU AUSTRALIAN PATENT OFFICE PO BOX 200 WODEN ACT 2606 AUSTRALIA  Facsimile No. 06 2853929		Authorized officer  BRIAND ASHWOOD  Telephone No. (06) 2832121																				

C(Continuation). DOCUMENTS CONSIDERED TO BE RELEVANT		
Category *	Citation of document, with indication, where appropriate of the relevant passages	Relevant to Claim No.
X	AU,B, 8942/61 (260680) (KINKELDER) 2 May 1963 (02.05.63) Pages 2-4, Figure 1, Claim 1	1,2,10,14
Y	FR,A, 2595205 (SACLIER) 11 September 1987 (11.09.87) Figures 1,4, Claim 1	6,7,8
Y	FR,A, 2623690 (GALLOIS) 2 June 1989 (02.06.89) Pages 1-3, Claim 1, Figures 1,2	3-9,12
Y	US,A, 4019682 (SMITH) 26 April 1977 (26.04.77) Columns 3,4, Claims 1,7,10 & 11, Figures 1-7	4,5,12

This Annex lists the known "A" publication level patent family members relating to the patent documents cited in the above-mentioned international search report. The Australian Patent Office is in no way liable for these particulars which are merely given for the purpose of information.

Patent Document Cited in Search Report	Patent Family Member
US 4019682	GB 1499816
<b>END OF ANNEX</b>	