



Europäisches Patentamt
European Patent Office
Office européen des brevets



(11) **EP 0 916 166 B1**

(12) **EUROPEAN PATENT SPECIFICATION**

(45) Date of publication and mention
of the grant of the patent:

05.06.2002 Bulletin 2002/23

(21) Application number: **97929142.4**

(22) Date of filing: **04.07.1997**

(51) Int Cl.7: **H01Q 1/24**

(86) International application number:
PCT/DK97/00295

(87) International publication number:
WO 98/01919 (15.01.1998 Gazette 1998/02)

(54) **A HANDHELD APPARATUS HAVING ANTENNA MEANS FOR EMITTING A RADIO
SIGNALAPPARATUS AND HOLDER**

TRAGBARES GERÄT MIT ANTENNE ZUM AUSSENDEN EINES FUNKSIGNALS

APPAREIL PORTATIF A SYSTEME D'ANTENNE POUR L'EMISSION DE SIGNAUX
RADIOELECTRIQUES

(84) Designated Contracting States:
DE FI FR GB SE

(30) Priority: **05.07.1996 DK 74296**

(43) Date of publication of application:
19.05.1999 Bulletin 1999/20

(60) Divisional application:
99124720.6 / 1 006 605
99124721.4 / 1 006 606

(73) Proprietor: **ROBERT BOSCH GMBH**
70442 Stuttgart (DE)

(72) Inventor: **JENSEN, Niels, J rgen**
DK-9492 Blokhus (DK)

(56) References cited:

EP-A- 0 017 037	EP-A- 0 214 806
EP-A- 0 451 623	WO-A-94/22235
US-A- 3 241 149	US-A- 4 661 992
US-A- 4 876 709	US-A- 5 530 919

EP 0 916 166 B1

Note: Within nine months from the publication of the mention of the grant of the European patent, any person may give notice to the European Patent Office of opposition to the European patent granted. Notice of opposition shall be filed in a written reasoned statement. It shall not be deemed to have been filed until the opposition fee has been paid. (Art. 99(1) European Patent Convention).

Description

[0001] The invention relates to a hand-help apparatus comprising antenna means for emitting a radio signal, and to such an apparatus comprising a shield which consists of an insulating material and surrounds some of the electronic components of the apparatus, and which is metallized on the side facing away from the components as well as on the side facing the components in order to shield radio frequency signals.

[0002] In e.g. modern mobile telephone systems the portable transmitter and receiver units are usually provided with antennas which have an omnidirectional radiation diagram, as this gives the greatest possible probability that a connection is established to the mobile telephone concerned at a given time, thereby facilitating the system planning of the system operators. Of course, also the users of the mobile telephones wish that the system has a coverage as good as possible.

[0003] The omnidirectional radiation diagram, however, has the drawback that the telephone will usually be arranged in such a manner with respect to a user's head that the head is present precisely where the electrical field from the antenna of the telephone is strongest. This means that a certain power loss will occur, as a part of the radiation energy dissipates in the head, and also involves the risk that precisely this energy dissipation may constitute a health hazard. Because of the possible health hazard in particular, it is therefore desired that the radiation should be directed away from the user's head.

[0004] A proposal for the solution of this problem is known from WO 94/22235, in which a shield element is arranged between the antenna and the user's head. The shield element is intended to absorb, block or reflect the electromagnetic radiation from the antenna. In an alternative embodiment, the shield is an integral part of the antenna itself. However, this solution has the drawback that with the radio frequencies used, which may e.g. be 900 MHz or 1.8 GHz, the extent of the shield in the longitudinal direction is of the same order as the wavelength, which will reduce the effect of the shield since its outermost end will act as an antenna to some extent. Since, in this solution, the radiation is mainly directed away from the user's head, the transmission/reception conditions of the telephone will moreover be impaired, unless a base station is present precisely in this direction. Therefore, the solution is useful only in areas where the base stations are located so close to each other that there will always be a sufficiently close base station in the direction concerned.

[0005] Another solution is known from WO 95/24746. Here, a so-called inverted F-antenna is placed on the rear side of the telephone so that the free end of the telephone is present at the end of the telephone which is positioned against the user's ear in use. This means that here too the radiation from the antenna is mainly directed away from the user's head, and the solution

therefore makes the same requirements with respect to the locations of the base stations as described above.

[0006] It is also known to provide a mobile telephone with two different antennas. US 5 530 919, e.g., describes an apparatus which has a built-in directional antenna and a rod antenna. The directional antenna is used as a transmitter antenna and the rod antenna as a receiver antenna. This apparatus, too, therefore relies on the presence of a base station in the direction in which the directional antenna is oriented, as the apparatus can only transmit in this direction. On the other hand, the rod antenna enables reception from all directions.

[0007] Also EP 214 806 describes an apparatus with a built-in directional antenna and a rod antenna. Both antennas are used here as receiver antennas in order to obtain receiver diversity, while only the rod antenna is used as a transmitter antenna. Thus, this apparatus does not avoid radiation into the user's head.

[0008] Particularly as regards mobile telephones, a small and Handy size is of great importance, and this therefore makes it necessary that the two antennas must be capable of being integrated in the apparatus without this adding considerably to the size of it. Since the omnidirectional antenna is already included in the design of most existing apparatuses, this means that it must be possible to incorporate the directional antenna without changing the design of the apparatus considerably.

[0009] The above-mentioned US 5 530 919 discloses an apparatus which has an incorporated antenna and a shield which is disposed between the antenna and the user's head. However, they are two separate components which therefore still take up some space. Accordingly, a further object of the invention is to provide an apparatus having a built-in patch antenna which takes up less space than in the known devices.

[0010] This is achieved, when the apparatus, as stated in claim 1, comprises a shield which surrounds some of the electronic components of the apparatus and consists of an insulating material metallized on the side facing away from the components as well as on the side facing the components, in that at least part of the metallization facing away from the components constitutes a patch antenna which is adapted to transmit and/or receive said radio signals.

[0011] Typically, devices of this type will be provided with a shield against radio frequency signals. It will usually be a metallized plastics shield which is metallized on both sides for reasons of production, so that in fact it is a double shield. When the outer side of the shield (or part thereof) is used as a patch antenna, the inner side of the shield can still serve the function of a shield against radio frequency signals, as stated in claim 2, while constituting the ground plane associated with the patch antenna.

[0012] Since the radiation diagram from such a patch antenna will be very directional, the desired radiation di-

agram is achieved in that the patch antenna, like in claim 3, is disposed on the side of the apparatus which, when used by a person, faces away from the person. For a mobile telephone, this will be the rear side of the telephone. The directional effect is achieved because the other metal parts and printed circuit boards of the telephone perform a shielding effect toward the person.

[0013] The invention will not be explained more fully below with reference to the drawing, in which

fig. 1 shows part of a circuit in an existing mobile telephone,

fig. 2 shows the structure of a patch antenna according to the invention,

fig. 3 shows the radiation from a mobile telephone having a patch antenna according to the invention,

fig. 4 shows the radiation from a mobile telephone having a patch antenna as well as an activated telescoping antenna,

fig. 5 shows a block diagram for an alternative embodiment of the invention, and

fig. 6 shows a mobile telephone placed in a specially adapted holder having a path antenna.

[0014] It is shown in fig. 1 how part of the circuit in existing mobile telephones may be designed. A printed circuit board 1 mounts a plurality of electronic components 2, and owing to incident and emanating radiation of radio frequency signals the components are surrounded by a shield 3, which typically consists of a plastics material 4 provided with a metallization 5, 6 on both sides. Metallization on one of the sides will normally be sufficient to perform the shielding function; but, generally, the shield will be metallized on both sides for reasons of production. This means that the metallization on the outer side may be used for other purposes.

[0015] It is shown in fig. 2 how this may be utilized for a patch antenna according to the invention. The metallization 6 is still present on the inner side of the plastics material 4, while the metallization 5 from fig. 1 on the areas 7 and 8 is removed. The metallization constitutes a patch antenna 9 on the central part of the outer side. This patch antenna, inter alia because of the shielding metallization 6, will particularly radiate radio frequency signals in a direction away from the plastics material 4 and thereby away from the components 2. The printed circuit board 1 itself and the other metal parts of the telephone will provide a further shielding effect in the opposite direction. Fig. 3 shows that when the shield 4 with the patch antenna 9 is placed on the rear side 10 of a telephone 11, a radiation diagram is obtained where the radiation 12 is directed away from the person 13 who uses the telephone. It will be seen that the telephone 11

is also provided with a rod antenna 14 which, in this situation, is not connected and therefore does not emit radio signals.

[0016] As appears from fig. 4, the rod antenna 14 may be arranged as a telescoping antenna which is connected only when it is extended. In that case, it has an omnidirectional radiation diagram, which means that when it is extended, the telephone 11, generally speaking, emits (and receives) radio signals equally well in all directions, and thus also in the direction of the person 13. The idea is thus that in areas having sufficient radio coverage, the radiation 12 from the patch antenna 9 will be sufficient to ensure connection, as there will usually be a sufficiently close base station in the direction of the radiation 12. The telescoping antenna 14 may thus be retracted and thereby be disconnected. Then, the person 13 will not be exposed to the strong radiation from the telephone. This corresponds to the situation shown in fig. 3.

[0017] In areas where the radio coverage is not good enough for this, the antenna 14 may then be extended and thereby connected so that the telephone 11 has the omnidirectional radiation diagram with the radiation 15. In this situation, which corresponds to fig. 4, the person 13 is exposed to radiation in the same manner as in ordinary mobile telephones which are just provided with an omnidirectional antenna; but, as mentioned, this will just be the case where the radio coverage is not very good. In practice, the radio coverage in urban areas will usually be sufficient for the situation in fig. 3 to be used, thereby avoiding exposing the person to the incident radiation, while outside the urban areas it will typically be necessary to supplement with the telescoping antenna and the associated incident radiation of radio energy. For the great majority of subscribers, the radiation to which they are exposed will thus be reduced considerably.

[0018] In the embodiment described above, the omnidirectional antenna 14 is thus connected in that the user himself extends it when the transmission/reception conditions so require. Fig. 5 shows a block diagram for an alternative embodiment. The signal to and from the antenna 4 is here connected to the transmitting/receiving circuit 16 of the telephone via a switch 17. A detecting circuit 18 can measure the field strength of a signal received on the patch antenna 9 and control the switch 17 in response thereto. If the field strength is above a predetermined threshold value, the connection between the antenna 14 and the transmitting/receiving circuit is disconnected, while, correspondingly, this connection is established when the field strength of the received signal is below this threshold value. Thus, the antenna 14 is connected only when the signal received on the patch antenna 9 is too low to ensure a good connection. Since transmission takes place to one and the same base station, the signal received will frequently be a sufficiently good indicator of whether the emitted signal is sufficiently strong. If, in this situation too, the antenna 14 is a tel-

escoping antenna, the full effect of this principle is achieved only if the antenna is extended, of course.

[0019] Alternatively, a special signal may be transmitted from the base station to the telephone if the signal received therefrom is too weak, and the detecting circuit 18 may then be adapted to receive this signal and control the switch 17 in response thereto. Hereby, it will be the signal received on the base station that decides whether it is necessary to connect the omnidirectional antenna 14.

[0020] With the patch antenna, described above, on the rear side of the telephone, it is also possible to obtain a much simpler connection to an external antenna in e. g. a car than has been possible in the past. An external antenna on e.g. the roof of the car is used for increasing the range of the telephone. Till now, the transfer of the radio frequency signals between the mobile telephone and the external antenna has usually taken place by means of coaxial cables, as the telephone e.g. has a coaxial connector in the bottom to which the external antenna may be connected.

[0021] According to the invention, however, the coaxial cables may be replaced by two patch antennas arranged opposite to each other, as will be seen in fig. 6. The holder 20, also called cradle, of the telephone is provided with a patch antenna 19 whose size corresponds to the size of the patch antenna 9 in the telephone, and which is arranged so that it will be right opposite it when the telephone is placed in the holder. The patch antenna 19 is connected to the external antenna by means of the cable 21. The holder 20 may moreover be provided with e.g. guide rails capable of ensuring that a telephone is always placed in the holder such that the two patch antennas are right opposite each other and at a well-defined distance from each other.

[0022] The radio frequency signals are thus transferred wirelessly between the two patch antennas. This means that the coaxial connectors may be saved, while obtaining a solution which is not subjected to wear, as is the case with the coaxial connectors.

Claims

1. A hand-held apparatus (11) for emitting radio signals and comprising a shield (3) which surrounds some of the electronic components (2) of the apparatus and consists of an insulating material (4) metallized on the side facing away from the components as well as on the side facing the components, **characterized in that** at least part of the metallization (5) facing away from the components constitutes a patch antenna (9) which is adapted to transmit and/or receive said radio signals.
2. An apparatus according to claim 1, **characterized in that** the metallization (6) facing the components is adapted to shield radio frequency components.

3. An apparatus according to claim 1 or 2, **characterized in that** the patch antenna (9) is placed in the side (10) of the apparatus which, when used by a person (13), faces away from the person.

Patentansprüche

1. Tragbare Vorrichtung (11) zum Aussenden von Funksignalen, die eine Abschirmung (3) aufweist, die einen Teil der elektronischen Bauelemente (2) der Vorrichtung umgibt und aus einem isolierenden Material (4) besteht, das auf der von den Bauelementen abgewandten Seite und auf der den Bauelementen zugewandten Seite metallisiert ist, **dadurch gekennzeichnet, daß** mindestens ein Teil der von den Bauelementen abgewandten Metallisierung (5) eine Patch-Antenne (9) bildet, die so ausgelegt ist, daß sie die Funksignale sendet und/oder empfängt.
2. Vorrichtung nach Anspruch 1, **dadurch gekennzeichnet, daß** die den Bauelementen zugewandte Metallisierung (6) so ausgelegt ist, daß sie Funkfrequenzkomponenten abschirmt.
3. Vorrichtung nach Anspruch 1 oder 2, **dadurch gekennzeichnet, daß** die Patch-Antenne (9) in der Seite (10) der Vorrichtung angeordnet ist, die bei Benutzung durch eine Person (13) von der Person abgewandt ist.

Revendications

1. Appareil portatif (11) pour émettre des signaux radio, comprenant un blindage (3) qui entoure certains des composants électroniques (2) de l'appareil et consiste en un matériau isolant (4) métallisé sur le côté tourné à l'opposé des composants ainsi que sur le côté tourné vers les composants, **caractérisé en ce qu'** une partie au moins de la métallisation (5) tournée à l'opposé des composants constitue une antenne plaquée (9) destinée à émettre et/ou recevoir les signaux radio.
2. Appareil selon la revendication 1, **caractérisé en ce que** la métallisation (6) tournée vers les composants est destinée à blinder les composants radiofréquence.
3. Appareil selon la revendication 1 ou 2, **caractérisé en ce que** l'antenne plaquée (9) est placée du côté (10) de l'appareil qui, lorsque l'appareil est utilisé par une personne (13), est tourné à l'opposé de cette personne.

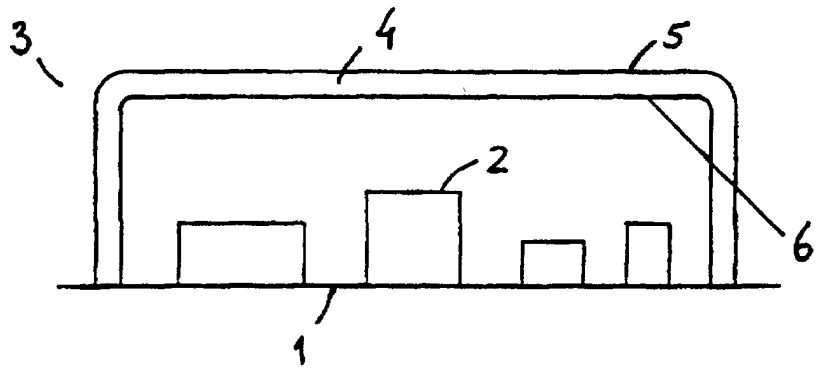

Fig. 1

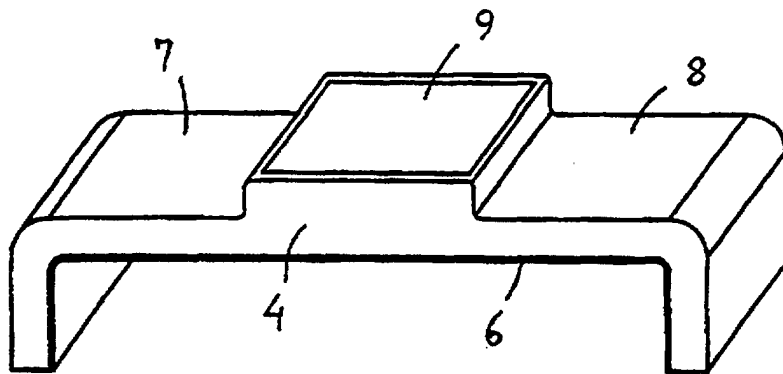

Fig. 2

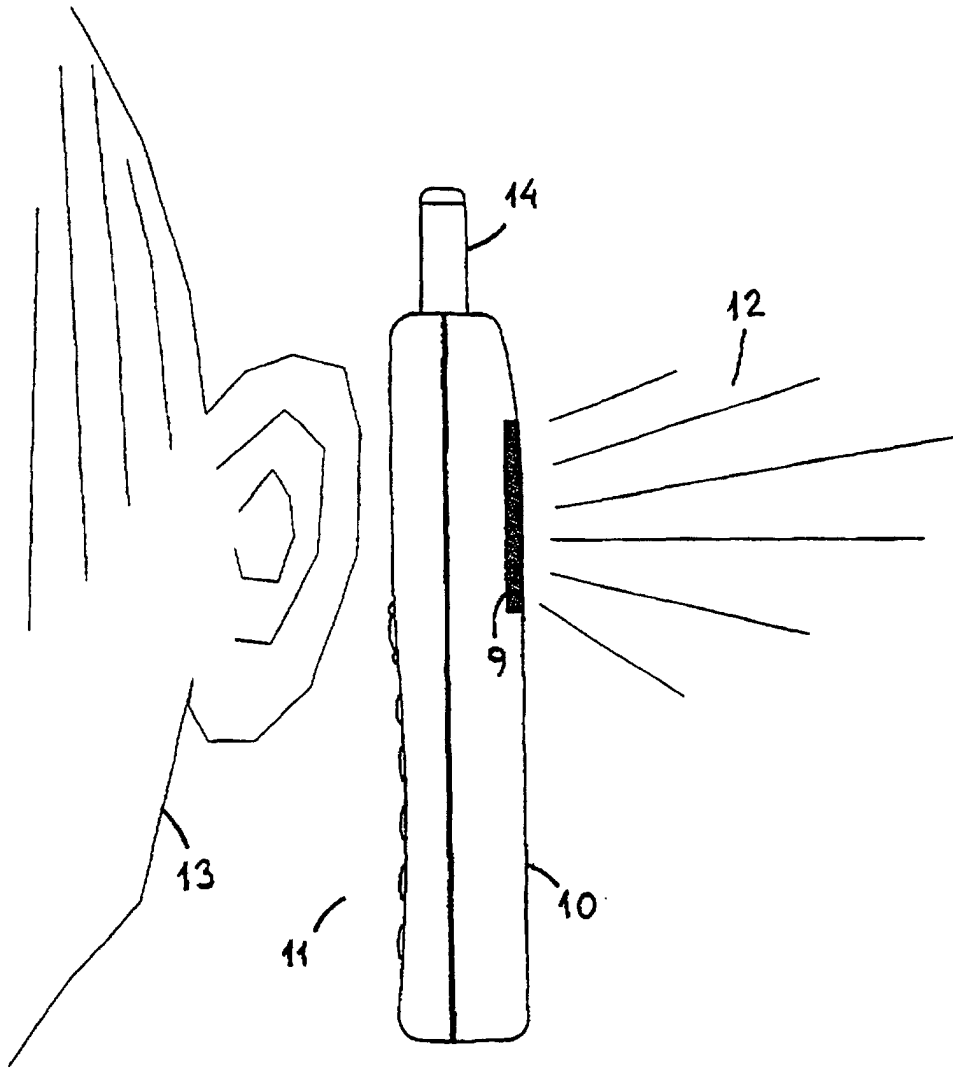

Fig. 3

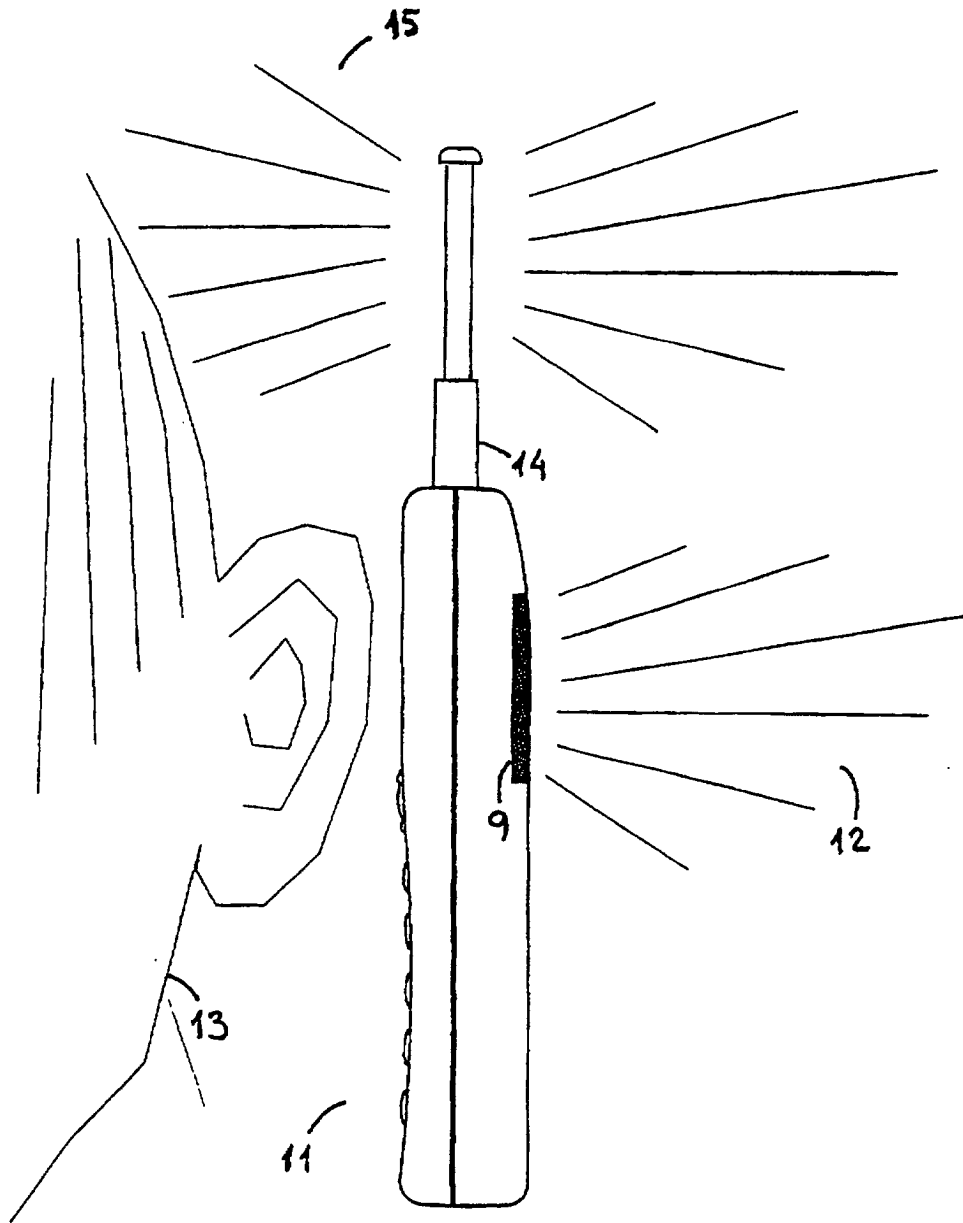

Fig. 4

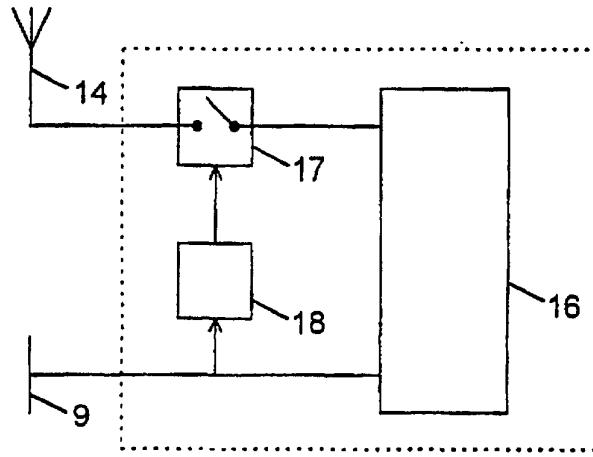

Fig. 5

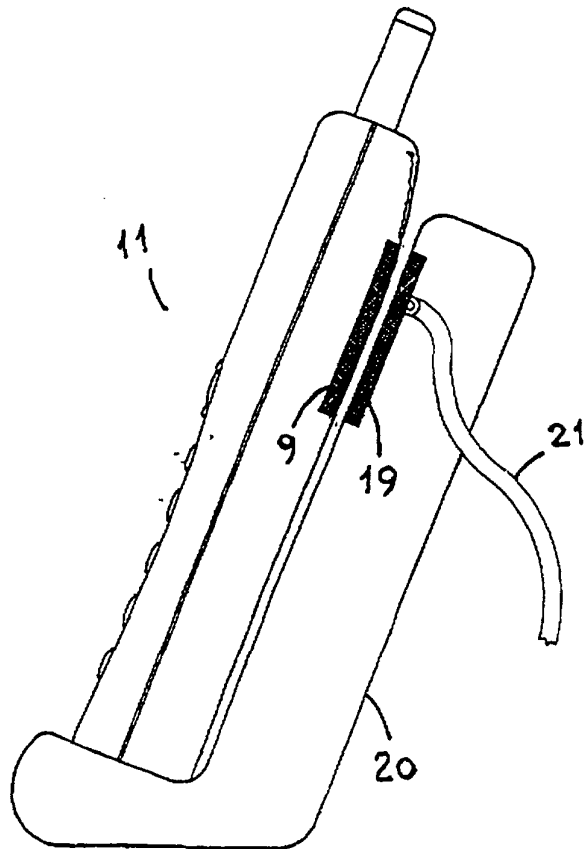

Fig. 6