



EUROPEAN PATENT APPLICATION

Application number : **91308241.8**

Int. Cl.⁵ : **E04B 9/34, E04B 9/12**

Date of filing : **10.09.91**

Priority : **10.09.90 GB 9019767**

Inventor : **Brugman, Johannes Antonius Henricus**
Groenetuin 85
3078 KC Rotterdam (NL)

Date of publication of application :
18.03.92 Bulletin 92/12

Designated Contracting States :
AT BE CH DE DK ES FR GB GR IT LI NL SE

Representative : **Allen, William Guy Fairfax et al**
J.A. KEMP & CO. 14 South Square Gray's Inn
London WC1R 5LX (GB)

Applicant : **HUNTER DOUGLAS INDUSTRIES B.V.**
Piekstraat 2
NL-3071 EL Rotterdam (NL)

A grid ceiling system.

This invention relates to a grid ceiling comprising a plurality of main runners (10), extending substantially parallel to one another, a plurality of transverse runners (12), extending substantially parallel to one another and transverse to the main runners (10), to define rectangular grid opening therewith, each of said runners being of generally channel shaped cross-section, including a lower web portion (14) joining two spaced side flanges (16,18), forming the upstanding sides of the main (10) and transverse runners (12), the longitudinal ends of the transverse runners (12) abutting upstanding sides of the main runners (10), grid elements located in each of said grid openings, each grid element including a plurality of parallel first grid members (64) and a plurality of parallel second grid members (66) transverse to the first grid members (64), generally channel shaped clips (50) engaged in the ends of said grid members (64,66), hooks (62) projecting from the ends of said clips (50), and apertures or recesses (28) in said runners (10,12) engageable by the hooks of said clips (50) to retain the grid elements in place, a least a number of the grid members (64,66) being adapted to be of modified length, as compared to the remainder of said grid members (64,66).

Fig. 1.

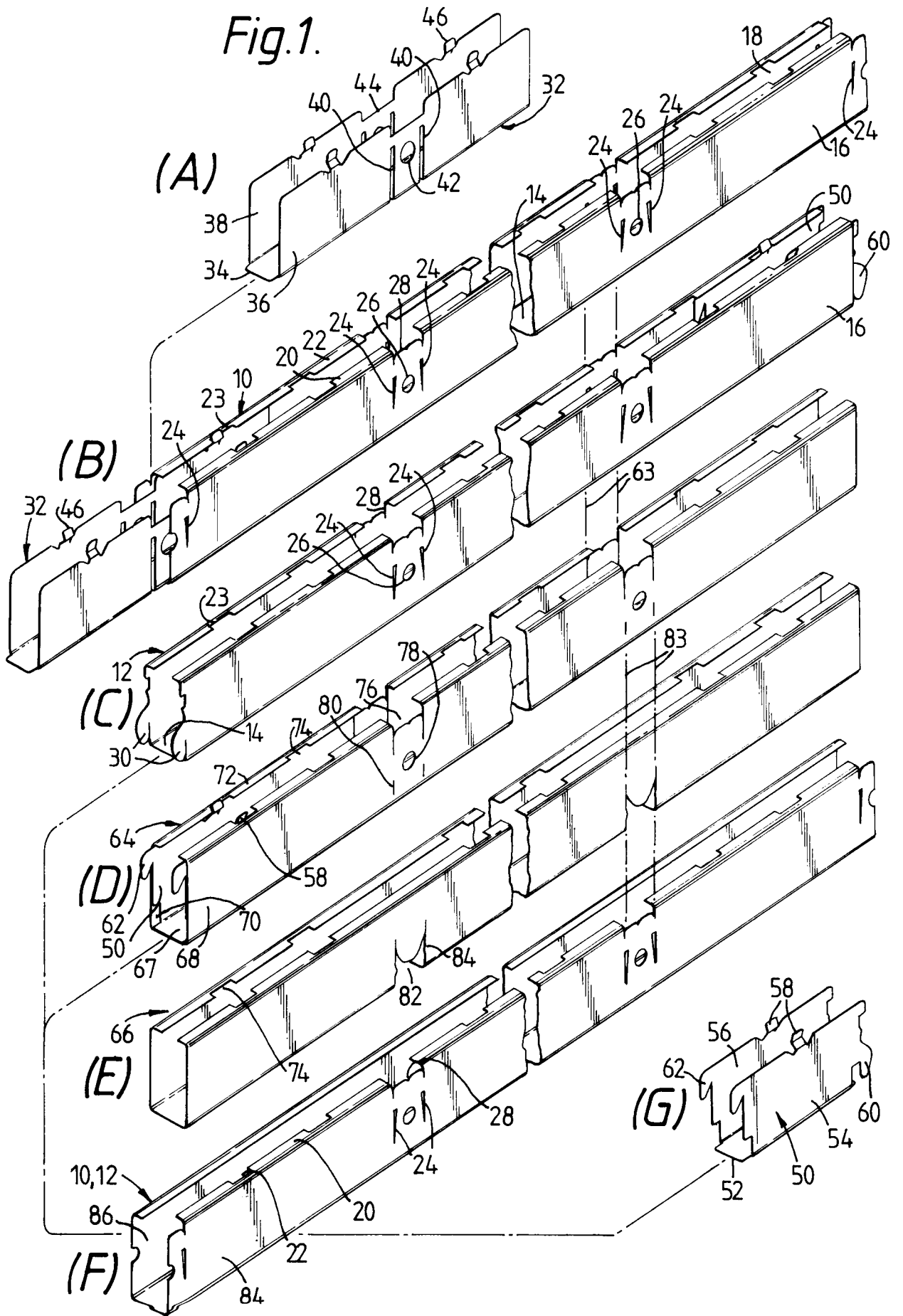

The present invention relates to grid ceilings.

There are many known types of grid ceiling such as, for example, as illustrated in GB-A-2173231 and 2173528. These ceilings comprise a number of runners in the form of a first elongate hollow member and a second elongate hollow member, the first and second hollow members each being of a channel shaped cross section including a lower web portion joining two spaced side flanges, forming the upper sides of the first and second members, the cross-section of at least the second members additionally comprising inturned rims along the upper edges of said side flanges, the second member being arranged transverse to the first member, with a longitudinal end of the first member abutting an upstanding side of the second member intermediate the longitudinal ends.

Mounted within the generally rectangular openings formed between the first and second sets of members, are grid elements which commonly are made of similar material to the grid members and are mounted by one form of clip or another.

A problem with all such grid ceilings is that the spacing between the elongate members (which is traditionally uniform at least for the first members and for the second members and often the spacing between the first members is the same as that between the second members) is not the same as the dimensions of the room in which the ceiling is being mounted and this can cause problems in making sure that the ceiling covers a uniform part or the whole of the ceiling to be covered.

It is now proposed, according to the present invention, to provide a grid ceiling comprising a plurality of main runners, extending substantially parallel to one another, a plurality of transverse runners, extending substantially parallel to one another and transverse to the main runners, to define rectangular grid opening therewith, each of said runners being of generally channel shaped cross-section, including a lower web portion joining two spaced side flanges, forming the upstanding sides of the main and transverse runners, the longitudinal ends of the transverse runners abutting upstanding sides of the main runners, grid elements located in each of said grid openings, each grid element including a plurality of parallel first grid members and a plurality of parallel second grid members transverse to the first grid members, generally channel shaped first clips engaged in the ends of said grid members, hooks projecting from the ends of said first clips, and apertures or recesses in said runners engageable by the hooks of said first clips to retain the grid elements in place, at least a number of the grid members being adapted to be of modified length, as compared to the remainder of said grid members.

With such a structure it is readily possible to adapt the grid ceiling to the size of the room in which the grid ceiling is to be mounted.

Preferably the main runners and the transverse runners are of the same cross-sectional size as the first and second grid members, and clips are engaged in the ends of said transverse runners, and apertures or recesses are formed in said main runners, said hooks of said clips engaging in said apertures or recesses to retain the transverse runners on the main runners.

In a preferred construction, the clips have at each end a pair of hooks, the hooks at one end being higher than those at the other end, the higher hooks being used to locate the transverse runners with respect to the main runners and the lower hooks being arranged to mount the grid elements on the runners.

It is contemplated that the channel section runners should include inturned rims at the upper edges of the flanges and that spaced notches be formed on these rims. Such a structure may be used in combination with a splicing element in the form of a channel section member engaged in a first of said runners adjacent the end thereof and extending beyond the end, said splicing elements having lugs engageable in the recesses formed in the rims, and wherein a second runner portion is engaged on the free portion of said splicing element and is secured to the runner thereby.

Additionally, or alternatively, the clip element or elements may include a lug, on each flange of the clip element, engageable in an opposite pair of said notches.

At least one of the main runners and/or of the transverse runners may have one flange which is provided with no apertures, recesses or notches, and this flange can be a flange which is visible at one side of the grid ceiling.

In order that the present invention may more readily be understood, the following description is given, merely by way of example, reference being made to the accompanying drawings in which:-

Figure 1 is a perspective exploded view showing the individual parts which may be used to form a grid ceiling according to the present invention; and

Figure 2 is an underneath plan of one embodiment of grid ceiling formed according to the invention.

If reference is first made to Figure 1, it will be seen that this is made up of seven portions, that is Figures 1A-1F. Figures 1B and 1C show main runners 10 and transverse runners 12, each in the form of channel section members having a lower web 14, and front and rear side flanges 16,18, each terminating in an upper inturned rim 20,22 respectively. The main and transverse runners 10,12 are each also provided at modular locations along the length of each of the side flanges 16,18, with pairs of slits 24, one on each axial side of an aperture 26, and with an upper recess 28. The transverse runners 12 are additionally provided,

at their ends, with downwardly directed hooks 30 on each side flange 16,18. These hooks are so positioned as to be engageable in the slits 24 of a main runner 10, thereby to define a main grid as illustrated in Figure 2.

Figure 1A illustrates a splicing element 32 which has many similarities to the main and transverse runners 10,12, and is of a slightly smaller dimension so as to be insertable in the main runner. Thus the splicing element is of channel cross-section having a web 34, and side flanges 36,38. Again, these side flanges are provided with slits 40, apertures 42, and recesses 44, located to align with the corresponding elements 24,26,28 in the main runner. The upper edges of the side flanges 36,38 are also provided with lugs 46. These splicing elements are used to connect, end to end, two main runners 10 to provide a more elongate structure. As seen in Figure 1B, with the splicing element located in the end of the main runner 10, the lugs 46 can be engaged in opposite notches 23, in the rims 20,22 of the main runner. In fact, this will be done in notches adjacent the ends of each of the two main runners to be connected by a such a splicing element.

At the right-hand end of the transverse runner 12 as seen in Figure 1C, the transverse runner has been shown cut off at the desired modular location to suit the size of the grid opening to be formed in the ceiling which is desired. In order to mount that end of the transverse runner on an adjacent main runner, a clip element 50, as seen in Figure 1G, is used. This again is of channel cross-section having a web 52, and side flanges 54,56, with upper lugs 58 on each of these side flanges.

At the right-hand end the clip element 50 is provided a hook 60 which is similar in configuration and location to the hook 30 on the end of the transverse runner 12. At the other end, and at a higher level, are further hooks 62, for a reason to be described shortly.

When the clip element 50 is inserted in the cut off end of the transverse runner 12, the lugs 58 are engaged in the adjacent notches 23, and the hook 60 projects outwardly as shown on the right in Figure 1C and thus in a manner similar to the hook 30 at the left end.

As indicated, the transverse runners can be cut off at any modular location as illustrated, for example, by the line 63 to provide a shorter length of transverse runner. Similarly the main runners 10 can be cut off at such locations, to suit a particular room size.

Figures 1D and 1E show first and second grid members 64,66 respectively. These are generally similar to one another and indeed are similar to the main and transverse runners 10,12 in their general structure. Thus, each consists of a lower web 67, and side flanges 68,70 provided with inturred rims 72, having notches 74. The first grid members 70 are of an underslung variety and have upper cut out 76, apertures 78 and short slits 80. The grid members

64,66 can be cut off at any modular location to a desired length, along cutting lines 83 which are conveniently at the location of the slits 80.

The second grid members 66 have lower cut outs 82 adapted to inter-fit with the cut out 76 in a conventional way, projections 84 on the sides of the cut outs 82 being adapted lockingly to engage in the short slits 80.

It will be seen that at the left-hand end, at least, of the first grid member 64, a clip 50 is inserted with the lugs 58 being engaged in adjacent notches 74. The hooks 62 at the left-hand end (as seen in Figure 1G) project outwardly of the first grid members 64 and are adapted to engage in recesses 28 in the main runners and/or in the transverse runners.

On occasions it is possible that the edge of the grid ceiling is spaced from the wall of the room and a slightly adapted main or transverse runner 10,12 is illustrated in Figure 1F. Here, the side flange 86 is shown as entirely plain, whereas the flange 84 is substantially identical to the flange 16 shown in Figure 1B and like parts have been indicated by like reference numerals.

If reference is now made to Figure 2, a grid ceiling made using the various components shown in Figure 1 is illustrated. Thus, it can be seen that the grid ceiling comprises three main runners 10, and three transverse runners 12, the transverse runners extending perpendicular to the main runners to define a number of differently shaped openings. Thus, there is a first square opening 90, a second rectangular opening 92, a third rectangular opening 94, and a fourth square opening 96. Each of these openings have therein a grid element 91,93,95,97 respectively. It will be noted that the central main runner 10 is made up of two parts 10a,10b, joined at the point 11 by a splicing element (not shown in Figure 2) as shown in Figure 1A. Similarly the left-hand transverse runner 12 is made of two parts 12a,12b, joined at 13 in a similar way. The grid element 91 is made up of two first grid members 64, and two secondary members 66, each of identical length. The second grid element 93 is made up of three first grid members 64, and two second grid members 66, the latter being longer than the former.

The third grid element 95 is made up of two first grid elements 64, and three second grid elements 66, these being shorter than the first grid members 64. Finally, the fourth grid element 97 is made up of three first grid members 64, and three second grid members 66, each of which is longer than the corresponding grid members 64,66 of the first grid element 91 thereby providing a square grid element which is larger than the grid element 91.

It can be appreciated that great versatility can be achieved by this method and that the runners and the grid elements can be adapted in their dimensions to suit a particular requirement of room dimension.

Claims

1. A grid ceiling comprising a plurality of main runners (10), extending substantially parallel to one another, a plurality of transverse runners (12), extending substantially parallel to one another and transverse to the main runners (10), to define rectangular grid opening therewith, each of said runners being of generally channel shaped cross-section, including a lower web portion (14) joining two spaced side flanges (16,18), forming the upstanding sides of the main (10) and transverse runners (12), the longitudinal ends of the transverse runners (12) abutting upstanding sides of the main runners (10), grid elements located in each of said grid openings, each grid element including a plurality of parallel first grid members (64) and a plurality of parallel second grid members (66) transverse to the first grid members, generally channel shaped first clips (50) engaged in the ends of said grid members (64,66), hooks (62) projecting from the ends of said first clips (50), and apertures or recesses (28) in said runners (10,12) engageable by the hooks of said first clips (50) to retain the grid elements in place, at least a number of the grid members (64,66) being adapted to be of modified length, as compared to the remainder of said grid members (64,66).

5

at one end being higher than those at the other end, the higher hooks being those of the second clips used to locate the transverse runners with respect to the main runners and the lower hooks being those of the first clips arranged to mount the grid elements on the runners.

2. A grid ceiling according to claim 1, wherein the main runners (10) and the transverse runners (12) are of the same cross-sectional size as the first and second grid members (64,66), and wherein second clips (50) of generally channel shape are engaged in the ends of said transverse runners (12), apertures or recesses (24) are formed in said main runners (10), and hooks (60) of said second clips (50) engage in said apertures or recesses to retain the transverse runners (12) on the main runners (10).

10

6. A grid ceiling according to any preceding claim wherein the channel section runners (10,12) include intumed rims (20,22) at the upper edges of the flanges, (14,18) and wherein spaced notches (23) are formed in said rims (20,22).

3. A grid ceiling according to claim 2 comprising clips (50) of generally channel shape, each clip forming one of said first clips (50) on one end and one of said second clips (50) on the other end.

15

7. A grid ceiling according to claim 6 and further comprising at least one splicing element (32) in the form of a channel section member engaged in at least one of said runners (10,12) adjacent the end thereof and extending beyond the end, said splicing elements (32) having lugs (46) engageable in the recesses (23) formed in the rims (20,22), and wherein a second runner portion (10,12) is engaged on the free portion of said splicing element (23) and is secured to the runner (10,12) thereby.

4. A grid ceiling according to claim 3, wherein the clips (50) have at each end a pair of hooks (60,62), the hooks (62) at one end being higher than those (60) at the other end, the lower hooks (60) being those of the second clips used to locate the transverse runners (12) with respect to the main runners (10) and the higher hooks (62) being those of the first clips arranged to mount the grid elements on the runners (10,12).

20

8. A grid ceiling according to claim 6 or 7, wherein the clip element (50) includes a lug (58), on each flange (54,56) of the clip element (50), engageable in an opposite pair of said notches (23).

5. A grid ceiling according to claim 3, wherein the clips have at each end a pair of hooks, the hooks

25

9. A grid ceiling according to any preceding claim, wherein at least one of said main runners (10) and/or said transverse runners (12) have one flange (86) which is provided with no apertures, recesses or notches.

3. A grid ceiling according to claim 2 comprising clips (50) of generally channel shape, each clip forming one of said first clips (50) on one end and one of said second clips (50) on the other end.

30

6. A grid ceiling according to any preceding claim wherein the channel section runners (10,12) include intumed rims (20,22) at the upper edges of the flanges, (14,18) and wherein spaced notches (23) are formed in said rims (20,22).

4. A grid ceiling according to claim 3, wherein the clips (50) have at each end a pair of hooks (60,62), the hooks (62) at one end being higher than those (60) at the other end, the lower hooks (60) being those of the second clips used to locate the transverse runners (12) with respect to the main runners (10) and the higher hooks (62) being those of the first clips arranged to mount the grid elements on the runners (10,12).

35

7. A grid ceiling according to claim 6 and further comprising at least one splicing element (32) in the form of a channel section member engaged in at least one of said runners (10,12) adjacent the end thereof and extending beyond the end, said splicing elements (32) having lugs (46) engageable in the recesses (23) formed in the rims (20,22), and wherein a second runner portion (10,12) is engaged on the free portion of said splicing element (23) and is secured to the runner (10,12) thereby.

5. A grid ceiling according to claim 3, wherein the clips have at each end a pair of hooks, the hooks

40

8. A grid ceiling according to claim 6 or 7, wherein the clip element (50) includes a lug (58), on each flange (54,56) of the clip element (50), engageable in an opposite pair of said notches (23).

6. A grid ceiling according to any preceding claim wherein the channel section runners (10,12) include intumed rims (20,22) at the upper edges of the flanges, (14,18) and wherein spaced notches (23) are formed in said rims (20,22).

45

9. A grid ceiling according to any preceding claim, wherein at least one of said main runners (10) and/or said transverse runners (12) have one flange (86) which is provided with no apertures, recesses or notches.

7. A grid ceiling according to claim 6 and further comprising at least one splicing element (32) in the form of a channel section member engaged in at least one of said runners (10,12) adjacent the end thereof and extending beyond the end, said splicing elements (32) having lugs (46) engageable in the recesses (23) formed in the rims (20,22), and wherein a second runner portion (10,12) is engaged on the free portion of said splicing element (23) and is secured to the runner (10,12) thereby.

50

8. A grid ceiling according to claim 6 or 7, wherein the clip element (50) includes a lug (58), on each flange (54,56) of the clip element (50), engageable in an opposite pair of said notches (23).

8. A grid ceiling according to claim 6 or 7, wherein the clip element (50) includes a lug (58), on each flange (54,56) of the clip element (50), engageable in an opposite pair of said notches (23).

55

9. A grid ceiling according to any preceding claim, wherein at least one of said main runners (10) and/or said transverse runners (12) have one flange (86) which is provided with no apertures, recesses or notches.

Fig. 1.

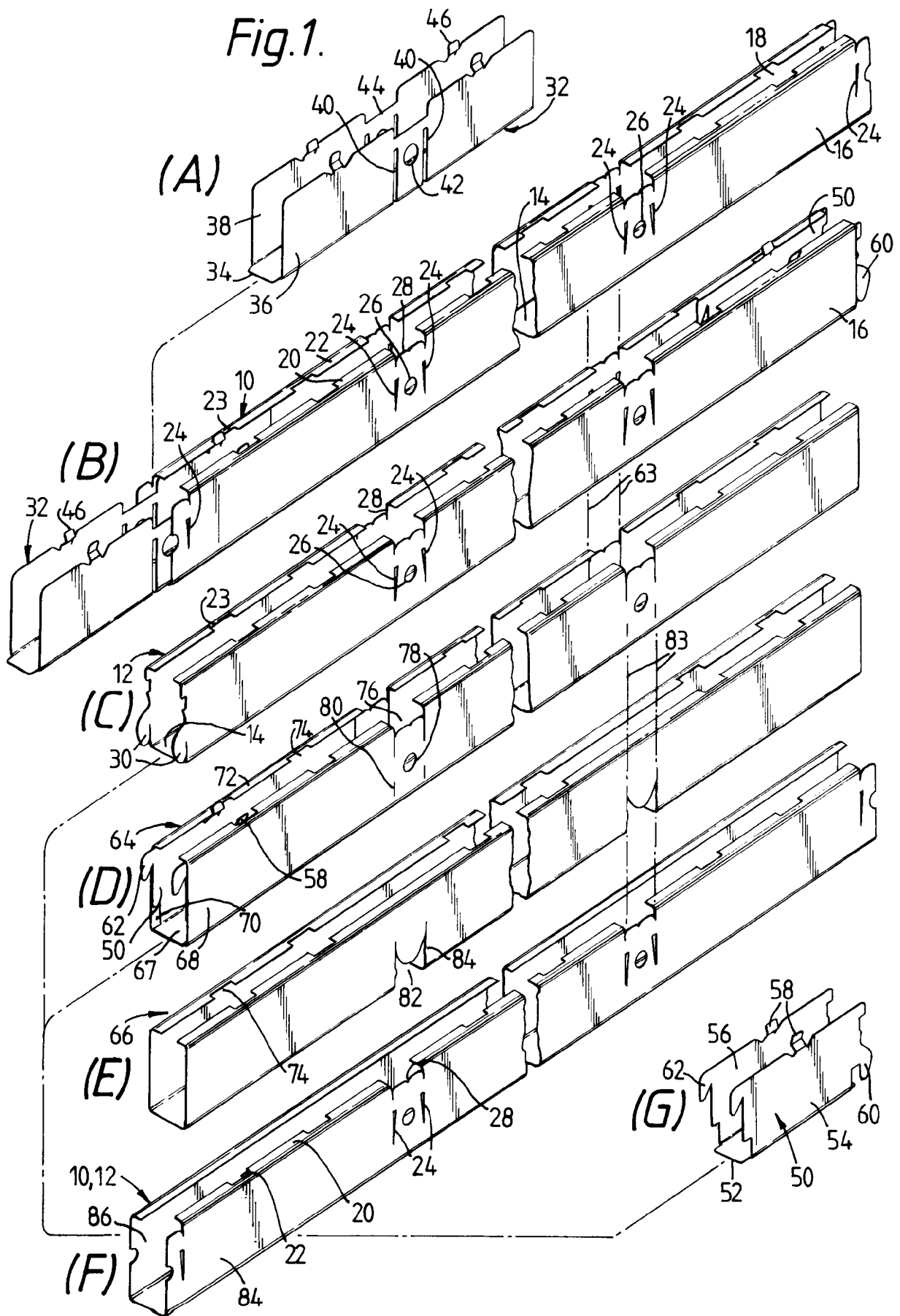



European Patent Office

EUROPEAN SEARCH REPORT

Application Number

EP 91 30 8241

DOCUMENTS CONSIDERED TO BE RELEVANT			
Category	Citation of document with indication, where appropriate, of relevant passages	Relevant to claim	CLASSIFICATION OF THE APPLICATION (Int. Cl.5)
Y, D	GB-A-2 173 528 (HUNTER DOUGLAS INDUSTRIES) * the whole document * ---	1, 2, 3, 6, 7, 8, 9	E04B9/34 E04B9/12
Y, P	GB-A-2 232 694 (HUNTER DOUGLAS INDUSTRIES) * the whole document * ---	1, 2, 3, 6, 7, 8, 9 4, 5	
A	US-A-4 850 172 (GAILEY) * column 6, line 5 - column 6, line 42; figures 2-4 * ---	1-5	
A	CA-A-1 194 666 (PRICE LTD) * claim 1; figures 1-4 * ---	1	
A	BE-A-707 992 (BERGERIOUX) * page 4, paragraph 1 - page 6, paragraph 2 * * page 7, paragraph 2 - page 7, paragraph 6; figures 1-4, 9-16 * -----	1, 7	
			TECHNICAL FIELDS SEARCHED (Int. Cl.5)
			E04B
The present search report has been drawn up for all claims			
Place of search THE HAGUE		Date of completion of the search 04 DECEMBER 1991	Examiner HENDRICKX X.
CATEGORY OF CITED DOCUMENTS X : particularly relevant if taken alone Y : particularly relevant if combined with another document of the same category A : technological background O : non-written disclosure P : intermediate document		T : theory or principle underlying the invention E : earlier patent document, but published on, or after the filing date D : document cited in the application L : document cited for other reasons ----- & : member of the same patent family, corresponding document	

EPO FORM 1503 (03/87) (P0401)