

No. 668,348.

Patented Feb. 19, 1901.

S. COON.

RAILROAD CROSSING SIGNAL.

(No Model.)

(Application filed July 13, 1900)

3 Sheets—Sheet 1.

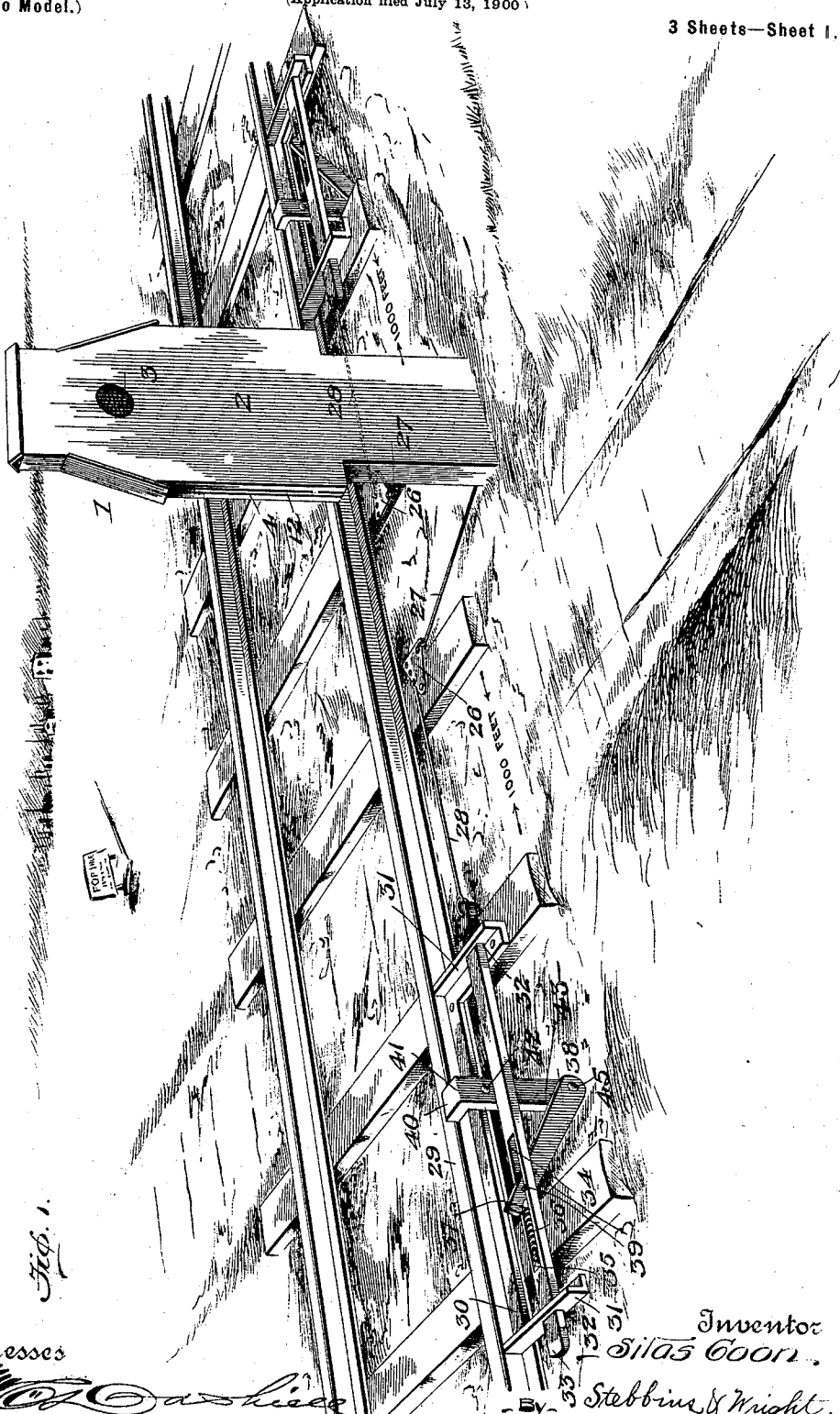

Fig. 1.

Witnesses

Wm. O. Ashlee
Bernard M. Offutt

Inventor
Silas Coon
 By *Stebbins & Wright*
 Attorneys.

No. 668,348.

Patented Feb. 19, 1901.

S. COON.
RAILROAD CROSSING SIGNAL.

(Application filed July 13, 1900.)

(No Model.)

3 Sheets—Sheet 2.

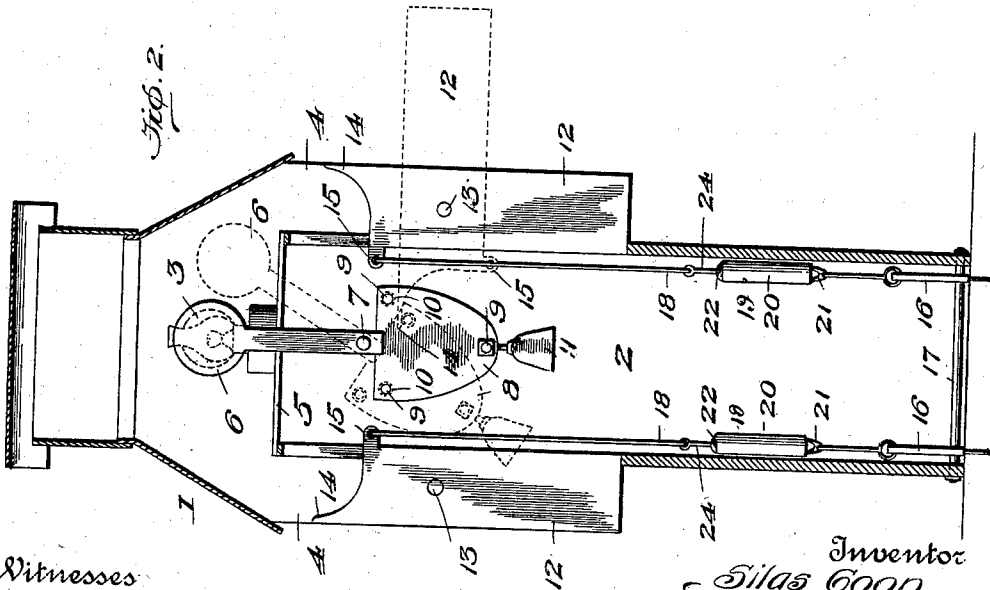
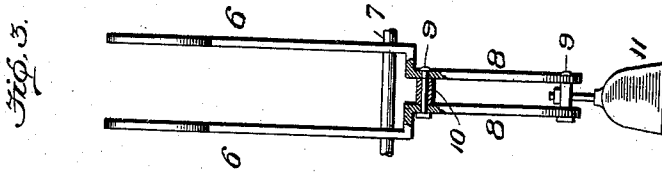
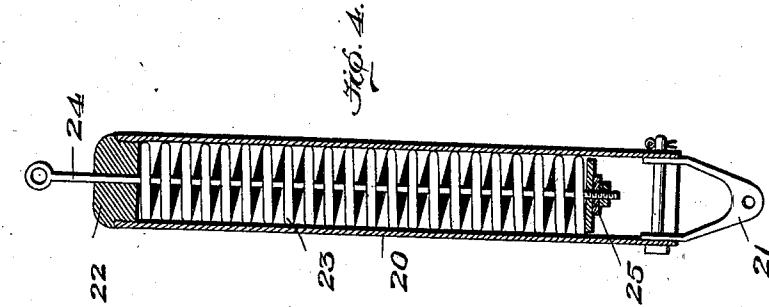

Witnesses

Wm. C. Sullivan
Bernard M. Offutt

Inventor
Silas Coon

By *Stebbins & Wright*,
Attorneys.

No. 668,348.

Patented Feb. 19, 1901.

S. COON.

RAILROAD CROSSING SIGNAL.

(No Model.)

(Application filed July 13, 1900.)

3 Sheets—Sheet 3.

Fig. 5.

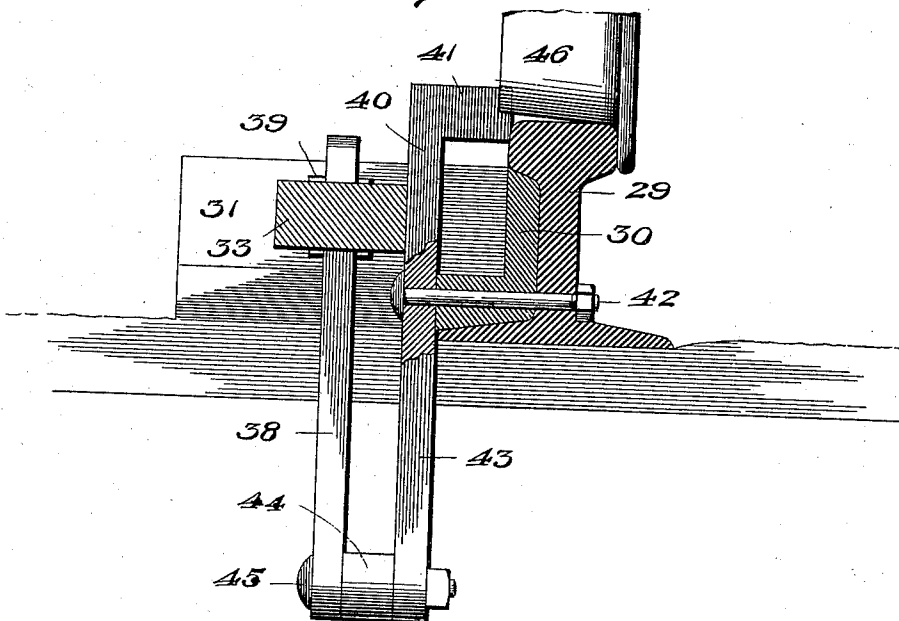

Fig. 6.

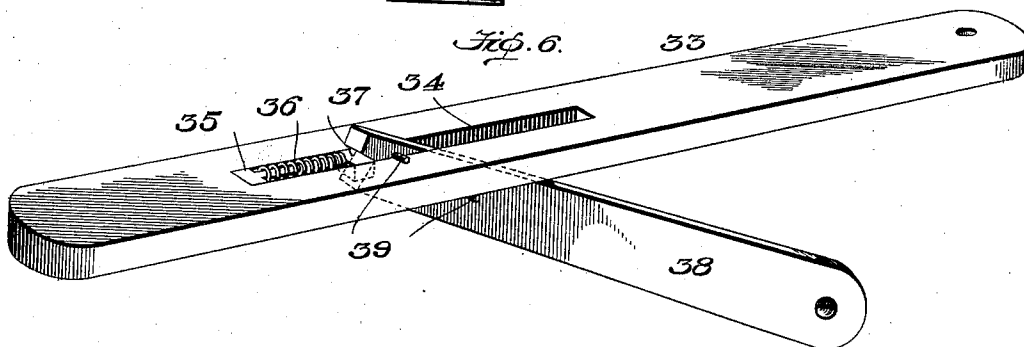
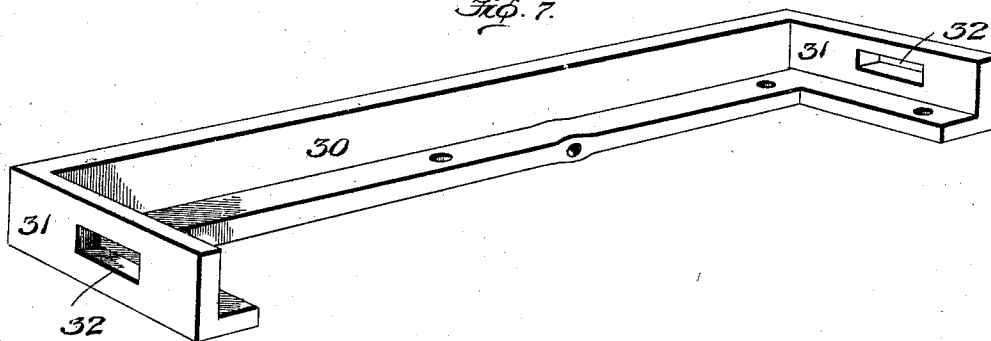

Fig. 7.



Witnesses

William A. Shaver
Bernard M. Offutt.

Inventor
Silas Coon

BY *Stebbins & Wright,*
Attorneys

UNITED STATES PATENT OFFICE.

SILAS COON, OF ASHLAND, KENTUCKY.

RAILROAD-CROSSING SIGNAL.

SPECIFICATION forming part of Letters Patent No. 668,348, dated February 19, 1901.

Application filed July 13, 1900. Serial No. 23,483. (No model.)

To all whom it may concern:

Be it known that I, SILAS COON, a citizen of the United States, residing at Ashland, in the county of Boyd and State of Kentucky, have
5 invented certain new and useful Improvements in Railroad-Crossing Signals; and I do hereby declare the following to be a full, clear, and exact description of the invention, such as will enable others skilled in the art to which
10 it appertains to make and use the same.

The object of my invention is the production of a crossing-signal which shall be operated by a passing train when going in either
15 direction or in one direction and upon a single or double track; which shall be automatic in operation, thus dispensing with the presence of an attendant; which shall display a light signal by night and a colored signal by
20 day; which shall sound a bell or gong by night and day; which shall be comparatively simple in construction and cheap to install and maintain, and which withal shall constitute a superior instrumentality for performing the functions of a reliable automatic
25 signaling device for crossings.

With the above end in view my invention consists in certain novelties of construction and combinations and arrangements of parts, hereinafter set forth, and specified in the
30 claims.

The accompanying drawings illustrate an example of the physical embodiment of my invention constructed according to the best mode I have so far devised for the practical
35 application of the principle.

Figure 1 is a perspective view of a railroad-track and a crossing with my signal apparatus shown in connection therewith, the signal-tower being located near the track and the
40 operating mechanism brought near the tower for the purpose of illustrating the several parts and the crossing-planks being removed to show the location of the connecting-wire.

Fig. 2 is a view of the tower with one of the sides removed. Fig. 3 is an illustration of the blinds and bell or gong detached from the tower. Fig. 4 shows one of the relief-spring mechanisms in section. Fig. 5 is a section of a rail and an elevational view of the lever
45 mechanism. Fig. 6 illustrates a sliding bar and an operating-bar in perspective. Fig. 7 shows a guide-frame in perspective.

Referring to the several views, the numeral 1 designates the signal-tower, made in any
55 suitable shape, of any suitable material, and of any desired dimensions; 2, the perpendicular sides, which may be of metal or wood; 3, two bull's-eyes located in the upper part of the tower; 4, perpendicular openings at the sides
60 of the tower; 5, a shelf for a lamp, located, as shown in Fig. 2, so that the flame of the lamp will be in line with the bull's-eyes; 6, the rocking blinds; 7, the pivot-bolt on which the
65 blinds rock; 8, the lower part of the blinds; 9, three bolts, which unite the lower parts; 10, ferrules on the bolts; 11, a bell or gong; 12, the rocking signal-blades, which may be of any desirable size, color, and material; 13, pivotal
70 pins or bolts about which the blades turn; 14, the projecting ends of the blades; 15, the arms of the blades; 16, triangular pivoted levers at the bottom of the tower; 17, a rod or bolt on which the levers are pivoted; 18, wires
75 which unite the levers and the arms of the blades; 19, relief-springs; 20, a tube; 21, an eye; 22, a cap with a central hole; 23, a spring; 24, a rod with an eye; 25, a nut and washer; 26, triangular levers pivotally secured to the
80 cross-ties; 27, wires uniting levers 16 and 26, as indicated in Figs. 1 and 2; 28, wires which extend along the track to any desired point; 29, a rail; 30, a frame, made of any material and secured to the rail and cross-ties; 31, arms
85 at right angles to the rail; 32, slots in the arms; 33, slide-bars; 34, slots in the slide-bars; 35, supports for springs in the slots; 36, relief-springs; 37, sliding blocks located in the slots; 38, operating-bars; 39, pins at
90 the ends of the bars; 40, levers or triggers; 41, the projecting ends of the levers adjacent the rail; 42, fulcrum-bolts; 43, the long arms of the levers; 44, washers; 45, bolts uniting the long arms of the levers and the operating-bars, and 46 is a fragment of a car-wheel.

The *modus operandi* of the signal mechanism is as follows: When a train approaches
95 from the left in Fig. 1, the tread of the wheel will strike the end 41 of the lever 40 and rotate it about the fulcrum-bolt 42, which action will force the operating-bar 38 against
100 the spring 36 and move the sliding bar 33 in the slots. The wire 28, secured to the end of the sliding bar, will rock the triangular lever 26, which in turn will rock the trian-

gular lever 16 and draw down the wire 18 in the tower. This movement rotates a blade 12 and throws it out to the position shown in Fig. 2. While being rotated to a horizontal position the projecting end 14 of the blade will engage a ferrule 10 and rock the blinds 6 from in front of the bull's-eyes, allow the light from the lamp to pass outwardly, and at the same time ring the bell or gong. This operation will of course be repeated as the end of the lever is successively struck by the wheels. The operation is the same when a train approaches from the right.

From the foregoing description, taken in connection with the illustrations, it becomes evident that I have produced a crossing-signal device which fulfils all the conditions set forth as the purpose or object of my invention.

While I have shown only one example of the physical embodiment of my improvement, I do not thereby intend to limit the scope of the invention to such specific example, inasmuch as many changes may be made in practical application of the same in different situations. The signal-tower may be of any dimensions desired and located in any position relative to the track and crossing, the light be of any color, the blades be of any shape, color, size, and material, the mechanism in connection with the track may be located at any distance from the tower, one thousand feet, as indicated, or at a greater or less distance therefrom, the lever mechanism be changed in form and construction, and the remaining elements of the mechanism altered at will. When a double track is used, the track mechanisms will of course be located on different tracks and the connections to the tower made in any desirable operative way.

Many other modifications may be introduced, equivalents substituted, and alterations made which are colorable in their nature, and the employment of which I shall not regard as constituting a substantial departure from my invention.

What I claim as new, and desire to secure by Letters Patent, is—

1. The combination in a railroad-crossing signal, of a tower provided with two bull's-eyes; two blinds suitably pivoted; a rocking signal-blade; a triangular lever at the bottom

of the tower; a wire uniting the blade and triangular lever; a lever or trigger in connection with the track; a sliding bar; and a wire uniting the sliding bar and the triangular lever in the tower.

2. The combination in a railroad-crossing signal, of a tower provided with two bull's-eyes; two blinds suitably pivoted in the tower; two signal-blades; two triangular levers at the bottom of the tower; wires connecting the triangular levers and the signal-blades; two operating mechanisms in connection with the track, one located at a suitable distance to the left of the tower and the other at the right of the tower, and each mechanism embracing a lever or trigger, an operating-bar, a slide-bar, and a wire uniting the slide-bar and a triangular lever at the bottom of the tower.

3. The combination in a railroad-crossing signal, of lever mechanism located adjacent the rail embracing an operating-lever; a trigger and a slide-bar; a tower containing a pivoted signal-blade having an arm and a projecting end; two blinds adapted to be operated by the projecting end of the blade; two bull's-eyes in the tower; and a wire uniting the signal-blade and the operating mechanism adjacent the track.

4. The combination in a railroad-crossing signal, of a tower having suitable signal mechanism therein; operating mechanism adjacent a rail consisting of a lever or trigger suitably pivoted, an operating-bar, a slide-bar having a slot and relief-spring; and a wire uniting the operating mechanism and the signal mechanism in the tower.

5. The combination in a railroad-crossing signal, of a tower having a bell or gong pivotally supported therein; means for moving the bell; operating mechanism adjacent a rail consisting of a pivoted lever or trigger adapted to be struck by a car-wheel, an operating-bar, and a slide-bar movable within slots made in a frame; and a wire uniting the slide-bar and the means for moving the bell.

In testimony whereof I affix my signature in presence of two witnesses.

SILAS COON.

Witnesses:

THEO. PFEIFER,
GEO. W. MOORE.