

No. 886,564.

PATENTED MAY 5, 1908.

K. WIESER.
MECHANICAL TIME FUSE.
APPLICATION FILED APR. 9, 1906.

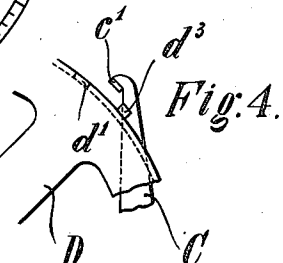
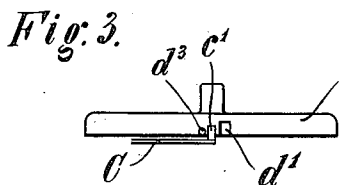
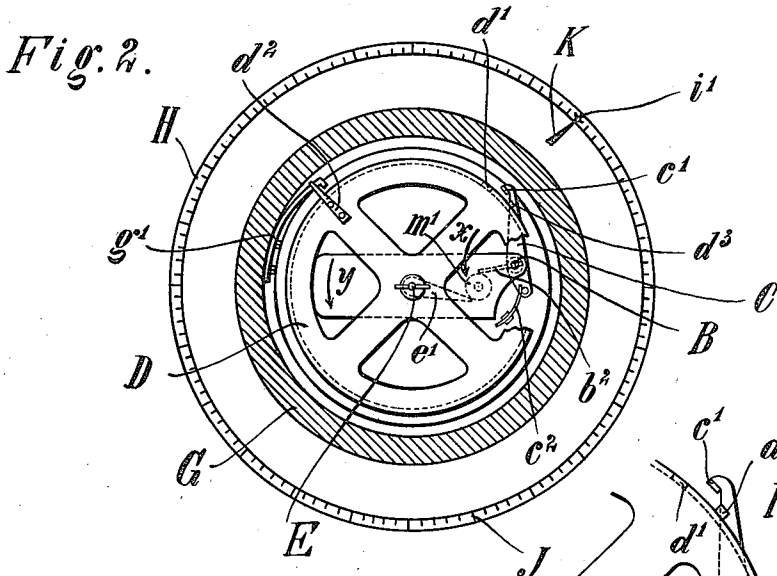
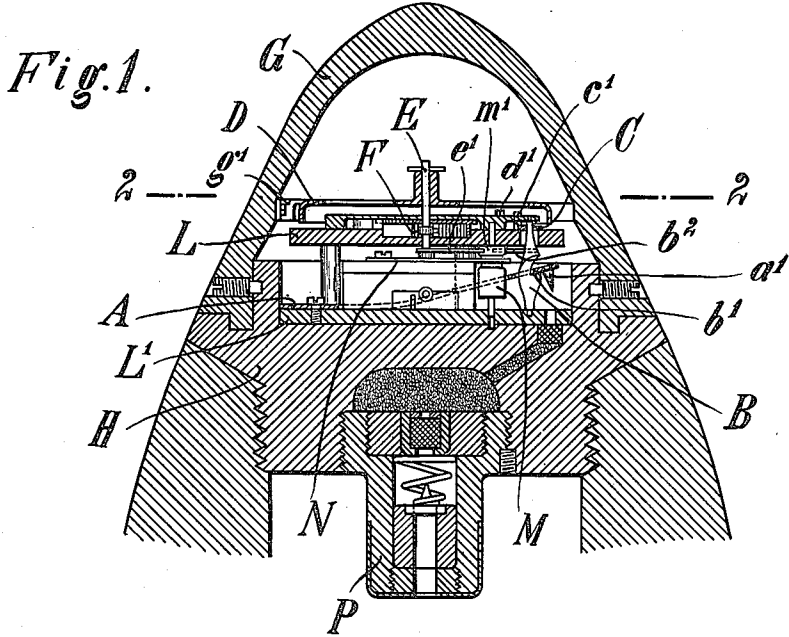

Witnesses
J. M. Olynck
H. A. Cotton

Inventor
Karl Wieser
By Knight
7/1/08

UNITED STATES PATENT OFFICE.

KARL WIESER, OF ESSEN-RÜTTENSCHIED, GERMANY, ASSIGNOR TO FRIED. KRUPP AKTIENGESELLSCHAFT, OF ESSEN-ON-THE-RUHR, GERMANY.

MECHANICAL TIME-FUSE.

No. 886,564.

Specification of Letters Patent.

Patented May 5, 1908.

Application filed April 9, 1906. Serial No. 310,802.

To all whom it may concern:

Be it known that I, KARL WIESER, a subject of the Emperor of Germany, and a resident of Essen-Rüttenscheid, Germany, have invented certain new and useful Improvements in Mechanical Time-Fuses, of which the following is a specification.

The present invention relates to mechanical time-fuses in which the igniting mechanism (igniting spring or the like) is held under tension through the medium of a rotatable locking-ring.

The object of the invention is to provide the time-fuse with a so-called "dead-point"; that is to say, provide means whereby the fuse may be adjusted to a position in which it cannot act as a time-fuse.

In the accompanying drawing, in which the invention is shown, by way of example, as applied to the fuse forming the subject matter of U. S. Letters Patent No. 728,151, granted May 12, 1903, to Carl Baker:—Figure 1 is a longitudinal section through the time-fuse, an impact fuse connected therewith and a part of the projectile; Fig. 2 is a section on line 2—2, Fig. 1, looking from above; Fig. 3 shows a detail in side-view, and Fig. 4 shows a part of Fig. 2 on an enlarged scale.

The general arrangement and mode of operation of the mechanical time-fuse selected to illustrate the use of my invention, is well known.

When the firing spring A, which carries the firing pin a' , is under tension, it lies against the shoulder b' , of the locking shaft B which carries the locking lever C with upwardly bent free end c' . The spring c^2 (Fig. 2) tends to turn the lever C and the shaft B in the direction of the arrow x (Fig. 2); that is to say, it tends to bring the shaft B in a position in which the shoulder b' releases the firing spring A.

D is the locking ring which is fitted on the spindle E of the clock-work (only partly shown) and which is provided with a notch d' permitting the passage of the end c' of the locking lever. The spindle E is engaged by the spiral spring F (Fig. 1) which, when under tension, tends to turn the spindle in the direction of the arrow y (Fig. 2). In order to adjust the time of ignition of the fuse by turning the cap G, the locking ring D is connected with the cap G by means of a coupling g' , d^2 , which is automatically released by centrif-

gal force developed in the rotation of the projectile.

In the plates L L', of the clockwork, a safety-bolt M is arranged in such a manner that it can move under its own inertia when the projectile is fired. A spring N tends to hold the bolt M in the securing position shown in the drawing. In this position the head m' of the bolt M is located in the path of travel of two arms e' and b^2 , one of which (e') is rigidly connected to the spindle E and the other (b^2) to the locking shaft B. The securing arrangement is so selected that the end c' of the locking lever is slightly spaced from the outer surface of the locking ring D when the arm b^2 of the locking shaft B lies against the head m' of the bolt M.

No invention *per se* is claimed for the arrangement as hitherto described, as it does not form the subject matter of the present application.

The outer face of the locking ring D is provided with a stop d^3 (Figs. 2 to 4) which is situated a short distance from the notch d' in the direction opposite the arrow y . The radial dimension of the stop is such that its path of rotation is not intersected by the end c' of the locking lever, when the arm b^2 lies against the head m' of the bolt M; consequently the locking lever C does not prevent rotation of the locking ring D in timing the fuse.

The impact fuse P arranged on the fuse body H is of known construction.

The outer face of the fuse body H is provided with a scale J (Fig. 2) while the cap G carries an index K. An arrow i' on the scale J indicates the dead point of the fuse.

In the transport condition of the mechanical time fuse, the springs A and F are under tension and the arms e' and b^2 lie against the head m' of the bolt M so as to prevent both the starting of the clock work and the turning of the locking shaft B, necessary for the release of the firing spring.

If it is desired to ignite the charge by means of the impact fuse P, and not by means of the mechanical time fuse, the cap G is adjusted to the position in which the index K registers with the arrow i' on the scale J. In this position of the cap (the dead point position of the fuse) the part of the locking ring D that lies between the notch d' and the stop d^3 is opposite the end c' of the locking lever.

When the projectile is fired off the bolt M

moves under its own inertia to such an extent that the arms e' and b^2 can swing freely outward. The clock-work starts and the spindle E turns in the direction of the arrow y and takes the locking ring D along with it. At the same time the lever C with the shaft B turns under the action of the spring c^2 and the end e' of the locking lever C swings against the locking ring D. In quick succession, the stop d^3 on the locking ring hits the end c^2 of the locking lever C so as to prevent further turning of the locking ring and the firing spring A is therefore held in the locked position and does not become released. When the projectile hits the target, the fuse P acts in the known manner.

It will be noted that the locking ring provides a spring-driven timing means, adjustable to determine the lapse of time prior to the action of the fuse, the ignition-controlling detent or means for producing ignition being controlled by the ring and adapted to engage or interlock with the ring to prevent the action of the ring when the latter is moved to a certain position. The stop d^3 serves as a locking-member with which the ignition-controlling detent is adapted for interlocking connection. It will be further noted that I provide a means thrown into locking engagement with the timing mechanism only when the fuse is projected, to prevent the action of the timing mechanism after the timing mechanism has been adjusted to a certain position.

Having thus described my invention, what I claim as new therein and desire to secure by Letters Patent is:

1. In a time fuse, a timing means adjustable to determine the lapse of time prior to the action of the fuse on the bursting charge and having in addition to its timing adjustment, a dead point adjustment at which the action of the time fuse is prevented.

2. A time fuse having means for timing the fuse by a predetermined movement; said timing means being movable to a point from which it can not move to release the firing means.

3. A time fuse having a timing means movable to determine the time that will elapse before a charge is ignited, and a detent adapted to engage said timing means when the timing means is moved to a dead point, to prevent movement of the timing means in the direction to cause ignition of the charge.

4. In a time fuse, the combination of the charge to be ignited, the means for igniting the charge, the timing mechanism releasing said igniting means by a predetermined movement of the timing mechanism; said timing mechanism being movable to a dead point from which it can not move to release the igniting means.

5. In a time fuse, the combination of the igniting means, the timing means moving to

a given point to release the igniting means and adjustable to different time points to vary the distance through which it moves to reach the releasing point, and also movable to a dead point beyond the time points, and a detent adapted to engage the timing means when the latter is set to the dead point.

6. In a time fuse, the combination of an igniting means, a locking ring controlling the igniting means movable to a point at which the igniting means is released and also adapted to be set at different time points to predetermine the distance through which the locking ring must move to reach the releasing point and also movable to a dead point from which it can not move to the releasing point, and a locking lever adapted to engage and arrest the ring when set at the dead point.

7. In a time fuse, the combination of the igniting means, the time mechanism rotatable from different time points at which it may be set to a point to release the igniting means, a locking arm through which said locking ring controls the igniting means, means actuated by the firing of the projectile to release said locking arm, and a projection on the locking ring through which the ring is engaged by the locking arm and arrested in its movement toward the releasing point when said ring has been previously set to a dead point.

8. In a time fuse, the combination of the firing device, the rotating shaft having a shoulder for retaining said firing device in inactive position, a locking arm controlling the rotation of said shaft, a locking ring having a recess to admit the locking arm when the ring reaches a point at which the firing means is to be released, a retaining device holding the locking arm normally away from the ring but releasing it when the projectile is fired to permit the locking arm to move against the ring, and a projection on the ring whose path is intersected by the locking arm after the latter is released, and when the ring has been previously adjusted to a dead point.

9. In a time fuse, the combination with the spring-driven timing-means adjustable to determine the lapse of time prior to the action of the fuse, of means for preventing the action of the timing-means when the timing-means is adjusted to a certain position.

10. In a time fuse, the combination with a locking-ring adjustable to determine the lapse of time prior to the action of the fuse, of means to engage the ring and prevent its movement when the latter has been adjusted to a certain position.

11. In a time fuse, the combination with a locking-ring adjustable to determine the lapse of time prior to the action of the fuse, of means for producing ignition controlled by said ring, said means being adapted to engage the ring when the latter is adjusted to a certain position, to prevent the action of the

12. In a time fuse, the combination with a locking-ring, of an ignition-controlling detent controlled by the ring and being adapted to interlock with the ring to prevent the movement of the ring when the latter is moved to a certain position.

13. In a time fuse, the combination of a time-adjustable locking-member, and an ignition-controlling detent adapted for interlocking connection with the locking-member to prevent the action of the locking-member.

14. In a time fuse, a spring driven time-adjustable locking-member and an ignition-controlling detent adapted for interlocking connection with the locking-member to prevent the action of the locking-member.

15. A time fuse having adjustable timing-mechanism, and means for preventing the action of the timing-mechanism when the latter is adjusted to a certain position.

16. A time fuse having adjustable timing-mechanism, and means for preventing the action of the timing-mechanism when the latter is adjusted to a certain position and thrown into locking engagement only when the fuse is projected.

The foregoing specification signed at Düsseldorf, this nineteenth day of March, 1906.

KARL WIESER.

In presence of—

WILLIAM ESSENWEIN,
PETER LIEBER.