

(19) World Intellectual Property
Organization
International Bureau



(43) International Publication Date
4 November 2004 (04.11.2004)

PCT

(10) International Publication Number
WO 2004/094823 A2

- (51) International Patent Classification⁷: **F04B** **R.** [US/US]; 52 James Brite Circle, Mahwah, NJ 07430 (US).
- (21) International Application Number: PCT/US2004/012797 (74) Agents: STUTIUS, Wolfgang, E. et al.; Ropes & Gray LLP, One International Place, Boston, MA 02110-2624 (US).
- (22) International Filing Date: 23 April 2004 (23.04.2004)
- (25) Filing Language: English (81) Designated States (unless otherwise indicated, for every kind of national protection available): AE, AG, AL, AM, AT, AU, AZ, BA, BB, BG, BR, BW, BY, BZ, CA, CH, CN, CO, CR, CU, CZ, DE, DK, DM, DZ, EC, EE, EG, ES, FI, GB, GD, GE, GH, GM, HR, HU, ID, IL, IN, IS, JP, KE, KG, KP, KR, KZ, LC, LK, LR, LS, LT, LU, LV, MA, MD, MG, MK, MN, MW, MX, MZ, NA, NI, NO, NZ, OM, PG, PH, PL, PT, RO, RU, SC, SD, SE, SG, SK, SL, SY, TJ, TM, TN, TR, TT, TZ, UA, UG, US, UZ, VC, VN, YU, ZA, ZM, ZW.
- (26) Publication Language: English
- (30) Priority Data: 60/465,070 23 April 2003 (23.04.2003) US
- (71) Applicant (for all designated States except US): BIO-VALVE TECHNOLOGIES, INC. [US/US]; One Innovation Drive, Three Biotech, Worcester, MA 01605-4307 (US).
- (72) Inventor; and (84) Designated States (unless otherwise indicated, for every kind of regional protection available): ARIPO (BW, GH, GM, KE, LS, MW, MZ, SD, SL, SZ, TZ, UG, ZM, ZW),
- (75) Inventor/Applicant (for US only): GONNELLI, Robert,

[Continued on next page]

(54) Title: HYDRAULICALLY ACTUATED PUMP FOR LONG DURATION MEDICAMENT ADMINISTRATION

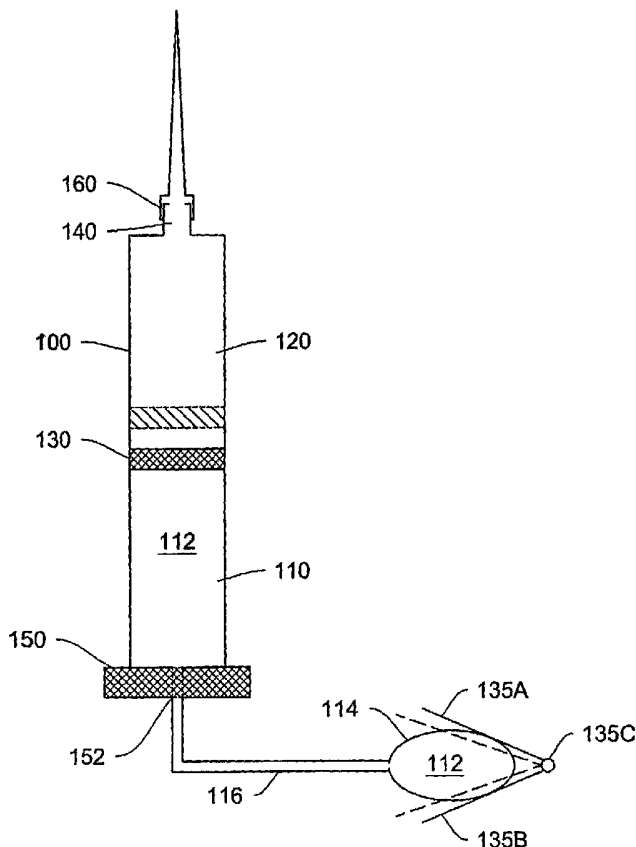

(57) Abstract: Presently disclosed is a hydraulic pump device and its use thereof, especially in a fluid delivery system. In one embodiment, the fluid delivery system is an inexpensive, single-use device for slow dosing medicament applications. The fluid delivery system may employ a spring-compressed bellows crank or other combination of simple mechanisms operating according to the well-known peristaltic principle to force a volume of ultrapure bio-inert hydraulic fluid through an aperture, thereby expanding one chamber of a two chamber hydraulic cylinder. The second, fluid storage chamber, containing the medicament, is emptied through a conventional orifice in response to the expansion of the pump chamber. The medicament may thence flow through any suitable infusion set into a patient removeably attached thereto.

WO 2004/094823 A2



Eurasian (AM, AZ, BY, KG, KZ, MD, RU, TJ, TM), European (AT, BE, BG, CH, CY, CZ, DE, DK, EE, ES, FI, FR, GB, GR, HU, IE, IT, LU, MC, NL, PL, PT, RO, SE, SI, SK, TR), OAPI (BF, BJ, CF, CG, CI, CM, GA, GN, GQ, GW, ML, MR, NE, SN, TD, TG).

For two-letter codes and other abbreviations, refer to the "Guidance Notes on Codes and Abbreviations" appearing at the beginning of each regular issue of the PCT Gazette.

Published:

— *without international search report and to be republished upon receipt of that report*

HYDRAULICALLY ACTUATED PUMP FOR LONG DURATION MEDICAMENT ADMINISTRATION

BACKGROUND OF THE INVENTION

The systems and methods described herein relate to a hydraulic pump system
5 that can be used in medicament pumps for injectibles, specifically to low-cost,
miniature, single-use pump systems.

Various people, such as diabetics, people require continuous or near
continuous infusion of certain drugs or medicines (broadly referred to herein as
medicaments).

10 Many attempts have been made to provide continuous or near continuous
dosing of medicaments, such as insulin, using pump systems. For example, one
known pumping technique uses gas generated by various means to advance a
plunger in a syringe, thereby injecting the medicament through an infusion set. The
infusion sets is a means for conveying medicament through the patient skin and may
15 comprise a standard needle, a microneedle, a microneedle array, and a catheter and
cannula system.

Although these systems can work quite well, patients using these systems,
particularly in continuous dose mode, need to monitor closely or deactivate these
devices under circumstances where the ambient air pressure may vary greatly, such
20 as in an airplane. In particular, patients need to be careful that the infusion pump
does not deliver a dangerously increased dosage in airplanes at high altitudes, where
the ambient pressure is significantly reduced.

What is needed is a simple, inexpensive, single-use only medicament pump
system. Such a system must have the capacity to provide variable dosing under
25 patient control as well as safety and consistency in the metered dose at any range of
ambient pressures or operating conditions.

SUMMARY

In an exemplary embodiment, the systems described herein include, *inter alia*, a pump device, which may be single use, and that that provides for sustained low volume (preferably high potency) medicament application, such as for use by
5 insulin-dependent diabetics and other patients. The pump may employ as an actuator a spring-compressed bellows crank, hinged plate, paired roller set, or other peristaltic mechanisms to force a volume of hydraulic fluid through a flow restrictor, such as an aperture, thereby expanding one chamber of a two chamber hydraulic cylinder. The second, fluid storage chamber, containing a medicament, is
10 vented through a conventional orifice as the hydraulic chamber is expanded by introduction of additional hydraulic fluid. The medicament thus expelled may then be injected or infused into a patient via any suitable injection and/or infusion mechanism.

The restrictor, in one embodiment, may be a hydraulic fluid aperture and may
15 be a fixed micro-aperture of approximately 0.1 - 10 μm in diameter, or about 1-5 μm in diameter, and one ten-thousandths of an inch (0.0001", or about 2.5 μm) in diameter. In another embodiment, the hydraulic fluid aperture may be an adjustable aperture providing either continuous or step-wise diameter variations of approximately 0.1 - 10 μm in diameter, or about 1-5 μm in diameter, preferably one
20 ten-thousandths of an inch (0.0001", or about 2.5 μm) in diameter. Combined with a hydraulic fluid of appropriate viscosity, the micro-aperture provides precise pressure regulation that is insensitive to ambient pressure or other environmental conditions. This insensitivity, in turns, allows for highly accurate dosing and dose regulation under a wider range of conditions than previously seen in the arts.

25 Thus one aspect of the invention provides a hydraulically actuated fluid delivery system for sustained delivery of a liquid component, comprising: a pump chamber, and a fluid storage chamber having an orifice and being functionally connected to said pump chamber by a moveable barrier; a hydraulic fluid reservoir for storing a high viscosity fluid, said reservoir being connected to said pump
30 chamber via a restrictor, such as an aperture, which may be less than 10 μm in

diameter, and the largest insoluble particle, if any, in said hydraulic fluid may optionally be no more than the size of said aperture; and, an actuator functionally connected to said hydraulic fluid reservoir to cause said hydraulic fluid to flow into said pump chamber through said aperture, thereby expanding the volume of said
5 pump chamber, displacing said moveable barrier and causing a quantity of said liquid component stored in said fluid storage chamber to be delivered at a sustained rate.

In one embodiment, the pump chamber and the fluid storage chamber are both within a compartment.

10 In one embodiment, the moveable barrier is a piston or plunger plate.

In one embodiment, the movement of the piston or plunger plate is guided such that the piston or plunger plate does not flip or generate leakage when moving.

In one embodiment, the moveable barrier is one or more deformable membrane separating the pump and the fluid storage chambers.

15 In one embodiment, the liquid component is a medicament, and the wall of the fluid storage chamber is composed of bio-inert materials.

In one embodiment, the aperture has a fixed size.

In one embodiment, the aperture is adjustable in size to allow variable hydraulic pressure.

20 In one embodiment, the size of the aperture is adjusted by a thumbwheel control / dial.

In one embodiment, the thumbwheel control activates a miniaturized valve or iris device.

25 In one embodiment, the quantity of said liquid component is expelled at a rate selected from: about 100 nl -1 μ l per minute, about 1-10 μ l per minute, or about 10-100 μ l per minute.

In one embodiment, the actuator is a miniaturized bellows crank, paired rollers, one or more piezoelectric elements, a ratchet or stepper motor driven unit, a two-plate hinged peristaltic mechanism, an electrically driven or piezoelectric mechanism.

- 5 In one embodiment, the actuator employs one or more external springs having a constant spring coefficient over its full range of motion.

In one embodiment, the fluid delivery system further comprises a connective passage linking the hydraulic fluid reservoir to the pump chamber through the aperture.

- 10 In one embodiment, the liquid component is a solution of a medicament.

In one embodiment, the medicament is insulin, an opiate, a hormone, a psychotropic therapeutic composition.

In one embodiment, the orifice of the fluid storage chamber is connected to an infusion set for delivering the liquid component to a patient.

- 15 In one embodiment, the patient is a mammalian patient selected from human or non-human animal.

In one embodiment, the infusion set is a needle, a lumen and needle set, a catheter-cannula set, or a microneedle or microneedle array attached by means of one or more lumens.

- 20 In one embodiment, the pump is manufactured with inexpensive material for single-use.

In one embodiment, the inexpensive material is latex-free and is suitable for use in latex-intolerant patient.

In one embodiment, the inexpensive material is disposable or recyclable.

- 25 In one embodiment, the inexpensive material is glass or medical grade PVC.

In one embodiment, the fluid delivery system further comprises a second hydraulic reservoir.

In one embodiment, the second hydraulic reservoir is separately and independently controlled by a second actuator.

5 In one embodiment, the second hydraulic reservoir and the original reservoir are both connected via a common connective passage and through the aperture to the pump chamber.

In one embodiment, the second hydraulic reservoir is connected to the pump chamber through a second aperture.

10 In one embodiment, one of the two hydraulic reservoirs is used for sustained delivery of the liquid component, and the other of the two hydraulic reservoir is used for a bolus delivery of the liquid component at predetermined intervals.

In one embodiment, both apertures are independently adjustable.

In one embodiment, one of the two apertures are adjustable.

15 In one embodiment, the sustained delivery is over a period of: more than 5 hours, more than 24 hours, more than 3 days, or more than one week.

In one embodiment, the viscosity of the hydraulic fluid is at least about ISO VG 20, or at least about ISO VG 32, or at least about ISO VG 50, or at least about ISO VG 150, or at least about ISO VG 450, or at least about ISO VG 1000, or at
20 least about ISO VG 1500 or more.

Another aspect of the invention provides a hydraulically actuated pump system comprising: a pump chamber functionally connected to a moveable barrier; a hydraulic fluid reservoir for storing a high viscosity fluid, said reservoir being connected to said pump chamber via an aperture of less than 10 and in some
25 embodiments less than 3 μm in diameter, and the largest insoluble particle, if any, in said hydraulic fluid is no more than the size of said aperture; and, an actuator

functionally connected to said hydraulic fluid reservoir to cause said hydraulic fluid to flow into said pump chamber through said aperture, thereby expanding the volume of said pump chamber, displacing said moveable barrier.

Another aspect of the invention provides a method of administering a
5 medicament, comprising: compressing a hydraulic fluid reservoir to force said hydraulic fluid through a connection means; passing said hydraulic fluid through an adjustable aperture into a pump chamber, wherein said pump chamber is separated from an adjacent fluid storage chamber by a moveable barrier and wherein said fluid storage chamber is filled with a medicament; displacing said moveable barrier into
10 said fluid storage chamber by filling said pump chamber with said hydraulic fluid, wherein said displacing causes a quantity of said medicament to be expelled from said fluid storage chamber through an output orifice.

In one embodiment, the passing is regulated by the adjustable aperture varying the flow of the hydraulic fluid and thus the quantity of the medicament
15 expelled through the orifice.

In one embodiment, the method further comprises injecting a quantity of the medicament into a patient through an infusion set connected to the orifice.

In one embodiment, the compressing employs peristaltic compaction of the reservoir at a constant rate.

20 In one embodiment, the compressing employs peristaltic compaction of the reservoir at a variable rate.

In one embodiment, the method further comprises rapidly compressing a second hydraulic reservoir fluidly connected to the pump chamber to displace the moveable barrier and thus cause a bolus of the medicament to be expelled through
25 the orifice.

In one embodiment, the method further comprises passing the hydraulic fluid from the second hydraulic reservoir through a second aperture into the pump chamber.

It should be understood that the individual embodiments described above are meant to be freely combined with one another, such that any particular combination may simultaneously contain two or more features described in different embodiments whenever appropriate. In addition, all embodiments described for one aspect of the invention (such as device) also applies to other aspects of the invention (e.g. method) whenever appropriate.

BRIEF DESCRIPTION OF THE DRAWINGS

The present disclosure may be better understood and its numerous features and advantages made apparent to those skilled in the art by referencing the accompanying drawings.

Figure 1 is a high-level functional schematic drawing of a hydraulic pump system, according to one embodiment of the invention.

Figure 2 is a high-level functional schematic drawing of a fluid delivery system comprising the hydraulic pump system, according to one embodiment of the invention.

Figure 3 is a schematic drawing illustrating one of the advantages of the fluid delivery system comprising the hydraulic pump system.

Figure 4 is a high-level functional schematic drawing of several fluid delivery system with various barriers.

Figure 5 is a high-level functional schematic drawing of an alternative fluid delivery system, according to one embodiment of the invention. The alternative fluid delivery system in this embodiment features arrayed microneedles on an transdermal patch.

Figure 6 is a high-level functional schematic drawing of several actuator mechanisms that can be used with the fluid delivery system employing the hydraulic pump, according to one embodiment of the invention.

Figure 7 is a high-level functional schematic drawing of the adjustable control for aperture opening size.

Figure 8 is a high-level functional schematic drawing of several fluid delivery system with multiple actuators, according to one embodiment of the invention.

The use of the same reference symbols in different drawings indicates similar or identical items.

DETAILED DESCRIPTION OF THE INVENTION

Described herein is a drug delivery system, uses thereof and methods for making the same. In one embodiment, the systems described herein provide pump devices for delivering a medicant, agent, fluid or some other material to a patient, typically through the skin. To this end, the system includes an actuator that operates on a reservoir of viscous fluid. The actuator causes the viscous fluid to apply pressure to medicant to the medicant being delivered. The viscous fluid is controlled by a restrictor that, in one practice, controls the rate of flow of the fluid so that an uneven application of pressure to the reservoir is mediated, and a controlled rate of fluid movement is achieved. This controlled rate of fluid movement is employed to cause a medicant to be delivered at a selected rate.

In one embodiment the systems and methods described herein include a hydraulic pump system that may include a chamber (the "pump chamber") that can be filled with high viscosity fluid, which, when forced by pressure, enters the pump chamber through a restrictor, for example an opening / aperture, which is dimensionally adapted to control the rate of fluid flow therethrough. In one embodiment, the aperture is about the size of a 1-100 μm diameter circle (but not necessarily circular in shape). However, those of skill in the art will understand that any suitable restrictor may be employed, and that the size and the shape of the restrictor can vary to achieve the desired flow rate of the fluid being mediated under the expected conditions, including temperature and ambient pressure.

The increase in volume of the working fluid inside the pump chamber triggers the movement of a barrier mechanism, which can be coupled to other devices, such as a second, fluid storage chamber.

5 One advantage of the instant hydraulic pump system resides with the restrictor through which the high viscosity working fluid flows. For example, when the restrictor is an aperture, when subjected to varying pressure, the working fluid enters the chamber through the aperture at a slow, yet relatively constant rate, thus mostly eliminating the potentially large variations in the force generating the pressure, while ensuring a substantially less variable expansion in volume of the
10 working fluid in the chamber. This in turn leads to a relatively smooth and constant movement of the coupled barrier mechanism.

An additional advantage of the hydraulic pump system is that its relatively low requirement for a constant pressure source, or its high ability to tolerate relatively large variations in force generated by the pressure source. This is
15 especially useful in manufacturing simple and inexpensive devices, such as single-use, disposable devices for medical use.

Partly because of the over-pressure employed in the hydraulic pump system, a further advantage is that the hydraulic pump is relatively insensitive to environmental changes, such as ambient temperature, altitude, or external pressure.

20 An illustrative embodiment of the hydraulic fluid system described herein is shown in the high-level functional drawing of Figure 1. The pump chamber 110 may be shaped like, but is not limited to, a cylinder. The hatched lines represent a moveable barrier 130, which may (but need not to) be at the distal end of aperture 152. Hydraulic fluid 112 enters aperture 152 on pump chamber wall 150 into pump
25 chamber 110, optionally via a connective passage 116.

As used herein, the term "ultrapure" is understood to encompass, although not be limited to, a fluid wherein the largest insoluble impurity particle in the working fluid is smaller than the aperture size (which may be for example about 2-3 μm in diameter, but could be smaller or larger, and may be adjustable). In those

embodiments wherein the restrictor is an aperture, the aperture need not be circular in shape, and could be an oval, a square, a rectangle, a triangle, a polygon, or irregular in shape. In those embodiments wherein the restrictor is a tube, valve, sieve, or other mechanism or combination of mechanisms, the size and shape of the restrictor may be determined empirically by testing the fluid flow of selected fluids at conditions of interest. In one particular embodiment, the largest impurity particle is no more than 1 mm in diameter, or no more than 500 nm in diameter, or no more than 100 nm in diameter. In addition, the total amount of insoluble impurity particle is less than 0.1%, or 0.01%, or 0.001% in volume.

Viscosity is ordinarily expressed in terms of the time required for a standard quantity of the fluid at a certain temperature to flow through a standard orifice. The higher the value, the more viscous the fluid. Since viscosity varies inversely with temperature, its value is less meaningful unless accompanied by the temperature at which it is determined. As used herein, "high viscosity" means the working fluid has a viscosity grade of at least about ISO VG 20, or at least about ISO VG 32, or at least about ISO VG 50, or at least about ISO VG 150, or at least about ISO VG 450, or at least about ISO VG 1000, or at least about ISO VG 1500. See www.superiorlubricants.com/classtable.html.

The hydraulic pump system can be employed in a fluid delivery system that can be manufactured inexpensively, and could take advantage of the slow, yet relatively constant delivery rate associated with the hydraulic pump system. Partly due to the slow rate of delivery, the fluid delivery system can be used to continuously deliver a fluid over a long period of time, e.g. 6 hrs, 12 hrs, 1 day, 3 days, 5 days, 10 days, one month, etc. The fluid delivery system comprises the hydraulic pump, coupled to a separate chamber for storing fluid to be delivered (the "fluid storage chamber" or "fluid chamber" in short). There could be various mechanisms coupling the movement of the barrier mechanism in the hydraulic pump to the fluid chamber, such that a small amount of fluid (ideally equal to, or at least proportional to the amount of the working fluid entering the hydraulic pump

chamber) is expelled from the fluid chamber, through one or more orifice, in response to the movement of the barrier.

One embodiment of the fluid delivery system is illustrated in a high-level schematic drawing in Figure 2 (see detailed description below). This type of fluid
5 delivery system / device can be used for a broad range of applications, including but are not limited to biomedical research (e.g. microinjection into cells, nuclear or organelle transplantation, isolation of single cells or hybridomas, etc.), and clinical applications (administration of medicaments, etc.).

For example, to provide a low level or variable dose of medicine over a long
10 period of time (e.g., hours or even days), the fluid delivery system may form a portion of a single-use dispenser for a medicament to be applied through any of the standard, infusions sets available on the market today or likely to be available in the future. The fluid delivery system, formed in some embodiments as low-cost plastic parts, may comprise a hydraulic cylinder containing two chambers, one function as
15 the pump chamber described above, the other the fluid chamber for storing medicaments. In those embodiments, the hydraulic cylinder may be configured similarly to most conventional hydraulic cylinders, and the wall, especially the inner wall of at least the chamber for storing a liquid medicament to be delivered, may be composed of bio-inert and inexpensive materials.

20 The following description is for principal illustration only, and should not be construed as limiting in any respect. Various illustrative alternative embodiments are described further below.

Hydraulic cylinder 100, as described in Figure 2, consists of two chambers, 110 and 120. Chamber 110 (corresponding to the pump chamber) is filled by
25 hydraulic working fluid 112 from a hydraulic reservoir 114. Filling is accomplished by means of a connective passage 116, such as (but not limited to) a tube or lumen either flexibly or rigidly connecting hydraulic reservoir 114 and hydraulic cylinder 100. As hydraulic fluid 112 is forced out of reservoir 114 by actuator 135 (consisting, in an exemplary embodiment, of peristaltic compression plates 135A

and 135B and hinge 135C), chamber 110 fills with hydraulic fluid expanding its volume and thus forcing piston element 130 (barrier mechanism) into chamber 120 (corresponding to the fluid chamber). The dotted lines in the actuator and the piston in Figure 2 represent the later-in-time position of a plate-hinge actuating mechanism,
5 and the later-in-time position of the barrier / piston.

Figure 3 is a schematic diagram illustrating one advantage of the fluid delivery system, e.g., its ability to tolerate relatively large variations in force generating the over-pressure, to create a relatively constant fluid delivery rate over time or distance traveled by the barrier piston. It is apparent that without the
10 hydraulic pump system, any direct use of force to expel fluid in the fluid chamber will be hard to control, and will be subjected to a large variation in delivery rate of the fluid (Figures 3A). In contrast, with the hydraulic pump, the delivery rate is much more constant (Figure 3B).

Chambers 110 and 120 can be, but are not necessarily separate, physical
15 chambers, since both chambers can exist within the confines of a hydraulic cylinder such as the one in Figure 2 (hydraulic cylinder 100). The chambers are separated by a moveable barrier, such as the piston element 130 in Figure 2, where piston 130 may be a fluid-tight barrier that prevents hydraulic fluid 112 from entering the second medicament fluid storage chamber 120. However, the invention is not
20 limited in the type of hydraulic cylinder 100 or the contours, dimensions or finishes of the interior surfaces of cylinder 100, chamber 110, or chamber 120. Furthermore, the invention is not limited to particular configurations of piston element 130. The following description illustrates several of many possible alternative embodiments that can be employed in the subject fluid delivery system.

25 In one embodiment, as shown in Figure 4A, the piston element 130 in Figure 2 is replaced by a flexible membrane 132 separating the pump chamber 110 and the fluid chamber 120. The flexible membrane can expand in response to the increased pressure from the pump chamber 110, due to the increase in volume of the working fluid entering the pump chamber 110 through aperture 152. This in turn expels fluid
30 from the fluid chamber 120 via orifice 140.

In another embodiment, as shown in Figure 4B, chambers 110 and 120 may each have a separate wall unit 134 and 136, respectively (such as expandable bags made from flexible materials). By virtue of being within the limited confinement of cylinder 100, the expansion in volume of chamber 110 necessarily leads to the
5 decrease in volume of chamber 120, creating a force to expel liquid from chamber 120 via orifice 140.

In yet another embodiment, as shown in Figure 4C, the pump chamber 110 and the fluid chamber 120 may be separated from each other, but are mechanically coupled through a barrier mechanism 138 that transmits movements in pump
10 chamber 110 to that in the fluid chamber 120. The coupling mechanism 138 can either augment or diminish the magnitude of the initial movement in the pump chamber 110, such that the corresponding movement in the fluid chamber 120 is increased, or decreased, respectively, resulting in expelling a larger or smaller amount of medicament fluid from the fluid chamber 120. For example, the coupling
15 mechanism 138 can be two pistons linked by a shaft, as shown in Figure 4C. In one embodiment, the fluid chamber 120 may be detached from the pump chamber 110, so that a new fluid chamber (120', not shown) may be re-attached.

As noted above, chamber 120 is to be initially filled with a quantity of liquid component to be delivered, such as a medicament. In the case of a medicament, the
20 quantity would typically be determined by a medical professional in order to provide the necessary dosing over a pre-determined period of time. The volume of the fluid chamber may be about 100 μ l, 500 μ l, 1 ml, 3 ml, 5 ml, 10 ml, 30 ml, 50 ml, 100 ml or more.

The depicted hydraulic cylinder 100 in Figure 2 can be further connected to
25 an infusion set 160 through orifice 140 at the distal end of chamber 120 (distal here meaning the end of chamber 120 distant from piston 130). In other words, the output orifice 140 of hydraulic cylinder 100 is on the opposite end of the cylinder from hydraulic fluid input aperture 152, as one would commonly expect in a hydraulic system. However, this is merely one of the preferred designs. The output orifice 140

could be located on the wall of cylinder 100 at the chamber 120 portion if desired (see Figure 5 below).

Attached to orifice 140, in some embodiments, is an infusion device or “set” 160 selected from any of the infusion means conventionally known and used in the medical arts. Examples of infusion devices include: a needle, such as depicted in Figure 1; a lumen and needle set; a catheter-cannula set; or a microneedle or microneedle array attached by means of one or more lumens. One of ordinary skill in the art will readily appreciate that many devices exist to convey medicaments into a body. Accordingly, the invention is not limited in the types of infusion or injection devices used therewith.

In an illustrative embodiment, as shown here in a high-level schematic drawing in Figure 5, the fluid delivery system is affixed to a delivery area of a patient, e.g. skin 200, by an adhesive means, such as a transdermal patch. The fluid chamber 120 is connected to a microneedle or an array of microneedles 180, such as those described in U.S. Pat. No. 6,503,231 (incorporated herein by reference). Unlike what is shown in Figure 5, the microneedle(s) need not completely enter the skin layer 200. To achieve a low profile, both the pump chamber 110 and the fluid chamber 120 may be flat in shape (rather than shaped like a cylinder), and the outer-surfaces may hug the contour of the attached skin layer 200. The orifice(s) (not shown) connecting the fluid chamber and the microneedle(s) preferably opens on a side-wall of the fluid chamber 120. Alternatively, a connective passage may link the orifice on fluid chamber 120 to the microneedle or microneedle(s) array. Barrier 130 and aperture 152 are as described above. Also shown is one embodiment of the actuator, where plates 135 actuated by spring mechanism squeeze the hydraulic fluid reservoir 114 to inject hydraulic working fluid into the pump chamber 110. Other actuators, such as those described in other parts of the specification, may be adapted for use in this embodiment.

As exemplified in Figure 2, in operation, the fluid (e.g. medicament) is administered by compressing hydraulic fluid reservoir 114 in a controlled manner with actuator 135. Figure 2 shows an exemplary peristaltic mechanism actuator

135. However, the actuator may be alternatively selected from any of a number of squeeze devices that apply a force on the reservoir, such as a miniaturized bellows crank or paired rollers bearing on reservoir 114 (see Figure 6 below). Moreover, in other embodiments, the reservoir can be acted on by an expanding gas volume,
5 thermal energy, or any other device or process that will be capable of causing the fluid to apply a pressure, either directly or indirectly, to the medicant being delivered.

In the embodiment shown in Figure 2, plates 135A and 135B are attached by hinge 135C and forced together by means of a spring or, in some embodiments, one
10 or more piezoelectric elements, such that flexible (e.g., elastomeric) hydraulic fluid reservoir 114 is squeezed between them. Squeezing an elastomeric reservoir forces the contents of the reservoir out through whatever aperture exists in the reservoir. In some embodiments, an aperture 152 is provided by the coupling tube 116 and the adjustable aperture 150, further described below.

15 Actuator 135 may also take on others forms. Ratchet or stepper motor driven units that compress plates or other structures bearing on hydraulic reservoir 114 that move hydraulic fluid may also be used without departing from the present invention. Additionally, for a two-plate hinged peristaltic mechanism such as that represented by reference designator 135 in Figure 2, springs mounted internally or externally to
20 the plates (not shown) may be used to force the plates together. Electrically driven or piezoelectric mechanisms, such as those described in the prior art, may also be employed.

In one embodiment, as shown in Figure 6A, one or more external spring(s) 135D having a constant spring coefficient over its full range of motion is (are)
25 employed. (For the sake of simplicity, a single spring configuration is described. But multiple springs may be used to adjust forces.) This spring is disposed so as to connect portions of plates 135A and 135B distant from hinge 135C and to draw them together (inwardly), thus bearing on reservoir 114. Thus, when the system is initially prepared for use, the spring is extended (i.e., placed in tension) by forcing
30 plates 135A and 135B apart. The plates are then held in place with a removable

brace or other device (not shown) to keep them from compressing hydraulic reservoir 114. Once the pump is in place and connected through infusion means 160 (see Figure 2, but not shown here) to inject the medicament into the patient, the brace may be removed. The constant spring tension placed on plates 135A and 135B of actuator 135 will then slowly force the plates together and squeeze hydraulic fluid 112 out of reservoir 114 in a peristalsis-like action.

In another embodiment, as illustrated in Figure 6B, a compressed spring or set of springs 260 may be used to push a piston element 250 through a guided-path to compress the hydraulic fluid reservoir 114. At the end of the reservoir, distal to the piston element 250, is an aperture 152 that allows the hydraulic fluid 112 to enter the adjacent pump chamber 110, so that barrier 130 may move accordingly. In a more simplified version, the spring mechanism 250 and 260 may be replaced by thumb force 300, just like in a traditional syringe (Figure 6C). In both Figures 6B and 6C, there is no connective passage separating the fluid reservoir 114 from the pump chamber 110.

The adjustable aperture provides regulation of the hydraulic pressure and flow rate in the pump chamber 110. This regulation may be effected by allowing the aperture 152 (in Figure 2) to be adjusted to extremely small dimensions, for example, to a diameter of one-ten thousandths of an inch (0.0001 inches, or about 2.5 μm) or less.

In one embodiment, the aperture 152 has a fixed size. It does not have to be round / circular in shape. For example, it could be roughly a square, a triangle, an oval, an irregular shape, or a polygon. Whatever the shape, the area of the opening will be sized to achieve the flow rate desired. In example, the opening may be about one-tenth thousandths of an inch (or 2-3 μm) in diameter. Depending on use, the opening size can be anything, including an opening between 200 nm – 500 nm, or 500 nm – 1000 nm, or 1-2 μm , or 5-10 μm . Other sizes and dimensions can be selected and the size and dimension selected will depend upon the application at hand.

In other embodiments, as shown in Figure 7, the aperture 152 may be adjustable in size, as by means of a conventional iris mechanism (see Figure 7), miniature valve, or paired gating slits (for example and not by way of limitation) currently known in the arts. For example, the adjustable aperture 152 may be
5 adjusted by means of a simple thumb wheel 150 that activates the conventional, miniaturized valve or iris device discussed above. In an alternate embodiment, an electrical motor or piezoelectric device may be used to open or close the aperture, thus affecting the rate at which hydraulic fluid 112 flows into chamber 110 and moves barrier 130.

10 Regardless of whether the aperture is adjustable or not, the flow rate of the hydraulic fluid can be controlled to suit different needs. In certain embodiments, the quantity of the fluid in the fluid chamber is expelled at a rate selected from: about 100 nl -1 μ l per minute, about 1-10 μ l per minute, or about 10-100 μ l per minute. In other embodiments, the fluid rate is mediated and controlled to be from .001 μ l per
15 hour to 100 milliliters per hour. The rate selected will depend upon the application at hand, and those of skill in the art will be able to determine the proper dosage rate for a given application.

One feature of aperture 152, whether adjustable or not, is that it can be made extremely small so that hydraulic fluid 112 enters chamber 110 at very low rates,
20 such as but not limited to rates as low as ones or tens of micro-liters per minute. When used with a hydraulic fluid of appropriate viscosity (further discussed below), the configuration of aperture 152 enables precise pressure regulation that is insensitive to ambient pressure or other environmental conditions. This insensitivity, in turns, allows for highly accurate dosing and dose regulation under a wider range
25 of conditions than previously seen in the arts.

Hydraulic fluid 112 is, in some embodiments, an ultrapure, high viscosity, bio-inert material. Viscosity is limited at its upper bound by the amount of force developed by the actuator. In certain embodiments, the force generated by the actuator is about 10 lb, 5 lb, 3 lb, 2 lb, 1 lb, 0.5 lb, 0.1 lb, .001 lb or less. At its lower
30 bound, the fluid must be viscous enough so that the flow can remain highly regulated

by the combination of actuator pressure and aperture diameter in all environment conditions, especially in the presence of low atmospheric pressure and/or high ambient temperature (where viscosity tends to decrease). A simple test may be performed to roughly determine the average flow rate of the hydraulic fluid, by
5 fixing an aperture size and the pushing force exerted on the fluid reservoir, and determining the amount of hydraulic fluid remaining in the reservoir (and thus the amount exited) after a period of time. Consecutive periods of hydraulic fluid loss (e.g. fluid loss in consecutive 5-minute periods, etc.) may be measured to determine if the rate of hydraulic fluid loss from the reservoir is constant over time under the
10 condition used.

Medicaments suitable for use with the system presently disclosed include: insulin, opiates and/or other palliatives, hormones, psychotropic therapeutic composition, or any other drug or chemical whose continuous low volume dosing is desirable or efficacious for use in treating patients. Note too that "patients" can be
15 human or non-human animal; the use of continuous dosing pumps is not confined solely to human medicine, but can equally applied to veterinarian medicines.

In an alternate embodiment of the system, two or more hydraulic reservoirs and actuators are provided (Figure 8). In an illustrative embodiment shown in Figure 8A, the first reservoir 400 and actuator 235 are the same as or similar to items 114
20 and 135 in Figure 2. The second reservoir 500 and actuator 235, which may use the same peristaltic actuator 135 as shown in Figure 2 or any other conventional alternative, such as those described above, are provided with a separate control. In other words, the second actuator may be controlled independently of the first. Both fluid reservoirs are connected to the pump chamber wall 150, through apertures 154
25 and 156, respectively. The connection may optionally go through connective passages 116. Such a configuration is useful in situations where special, discrete doses of the medicament may be necessary. For example, an insulin-dependent diabetic may often find it necessary to receive an additional booster dose or bolus of insulin immediately after meals, in addition to and along with continuously supplied

insulin during the day. The second actuator control may thus be operated independently of the first actuator control mechanism to deliver the bolus.

In an alternative embodiment, shown in Figure 8B, hydraulic fluid 112 from both reservoirs 400 and 500 may pass together through a common lumen 116 and
5 thence through adjustable aperture 152 (Figure 8B). Alternatively, as described above, the two reservoirs may lead into hydraulic chamber 110 by way of separate lumens and separately adjustable apertures 154 and 156 (Figure 8A). In this latter configuration, the rate of dosing affected by either reservoir may be independently controlled through their respective adjustable apertures.

10 In a further alternative, one of the reservoirs may lead to a fixed aperture while the other leads to an adjustable aperture. In this embodiment, useful in cases such as the insulin-dependent diabetic described above, the fixed-aperture-connected hydraulic reservoir can be actuated to provide bolus dosing at discrete intervals, while the adjustable-aperture-connected hydraulic reservoir can be used to provide
15 continuous slow dosing.

EXEMPLARY EMBODIMENT USING THE FLUID DELIVERY SYSTEM

In one exemplary embodiment, there is provided a method of administering a medicament, comprising: compressing a hydraulic fluid reservoir to force said hydraulic fluid through a connection means; passing said hydraulic fluid through an
20 adjustable aperture into a first, pump chamber, wherein said pump chamber is separated from an adjacent fluid storage chamber, for example, by a moveable barrier, and wherein said fluid storage chamber is filled with a medicament; displacing said moveable barrier into said fluid storage chamber by filling said pump chamber with said hydraulic fluid, wherein said displacing causes a quantity of said
25 medicament to be expelled from said fluid storage chamber through an orifice.

Said passing may be regulated by said adjustable aperture varying the flow of said hydraulic fluid and thus the quantity of said medicament expelled through said orifice. Furthermore, the method may further comprise injecting a quantity of said medicament into a patient through an infusion set connected to said orifice.

In some embodiments, the step of compressing may employ peristaltic compaction of said reservoir at a constant rate. Alternatively, the compressing step may employ peristaltic compaction of said reservoir at a variable rate.

5 In yet another alternate embodiment, the method may further comprise rapidly compressing a second hydraulic reservoir fluidly connected to said pump chamber to displace said moveable barrier and thus cause a bolus of said medicament to be expelled through said orifice. This embodiment may further comprise passing said hydraulic fluid from said second hydraulic reservoir through a second aperture into said pump chamber.

10 Alternate Embodiments

The order in which the steps of the present method are performed is purely illustrative in nature, and may not need to be performed in the exact sequence they are described. In fact, the steps can be performed in any suitable order or in parallel, unless otherwise indicated as inappropriate by the present disclosure.

15 While several illustrative embodiments of the hydraulic pump system and its use in the fluid delivery system have been shown and described, it will be apparent to those skilled in the art that changes and modifications may be made without departing from this invention in its broader aspect and, therefore, the appended claims are to encompass within their scope all such changes and modifications as
20 fall within the true spirit of this invention.

CLAIMS:

1. A hydraulically actuated fluid delivery system for sustained delivery of a liquid component, comprising:
 - 5 a pump chamber, and a fluid storage chamber having an orifice and being functionally connected to said pump chamber by a moveable barrier;
 - a hydraulic fluid reservoir for storing a high viscosity fluid, said reservoir being connected to said pump chamber via a restrictor capable of controlling the rate of flow of the high viscosity fluid,
 - 10 and,
 - an actuator functionally connected to said hydraulic fluid reservoir to cause said hydraulic fluid to flow into said pump chamber through said restrictor, thereby expanding the volume of said pump chamber, displacing said moveable barrier and causing a quantity of said liquid
 - 15 component stored in said fluid storage chamber to be delivered at a sustained rate.
2. The fluid delivery system of claim 1, wherein said pump chamber and said fluid storage chamber are both within a compartment.
3. The fluid delivery system of claim 2, wherein said moveable barrier is a
20 piston or plunger plate.
4. The fluid delivery system of claim 3, wherein the movement of said piston or plunger plate is guided such that said piston or plunger plate does not flip or generate leakage when moving.
5. The fluid delivery system of claim 2, wherein said moveable barrier is one or
25 more deformable membrane separating said pump and fluid storage chambers.
6. The fluid delivery system of claim 1, wherein the liquid component is a medicament, and the wall of said fluid storage chamber is composed of bio-inert materials.
- 30 7. The fluid delivery system of claim 1, wherein said restrictor comprises an aperture having a selected size.

8. The fluid delivery system of claim 1, wherein said restrictor is adjustable in size to allow variable hydraulic pressure.
9. The fluid delivery system of claim 7, wherein the size of said aperture is adjusted by a control dial.
- 5 10. The fluid delivery system of claim 9, wherein said control activates a miniaturized valve or iris device.
11. The fluid delivery system of claim 1, wherein said quantity of said liquid component is expelled at a rate selected from: about 100 nl -1 μ l per minute, about 1-10 μ l per minute, about 10-100 μ l per minute, about 100 μ l – 100
10 milliliters per hour.
12. The fluid delivery system of claim 1, wherein said actuator comprises a miniaturized bellows crank, paired rollers, one or more piezoelectric elements, a ratchet or stepper motor driven unit, a two-plate hinged peristaltic mechanism, an electrically driven or piezoelectric mechanism.
- 15 13. The fluid delivery system of claim 1, wherein said actuator employs one or more external springs.
14. The fluid delivery system of claim 1, further comprising a connective passage linking said hydraulic fluid reservoir to said pump chamber through said aperture.
- 20 15. The fluid delivery system of claim 1, wherein said liquid component is a solution of a medicament.
16. The fluid delivery system of claim 15, wherein said medicament is insulin, an opiate, a hormone, a psychotropic therapeutic composition.
17. The fluid delivery system of claim 1, wherein said orifice of said fluid
25 storage chamber is connected to an infusion set for delivering said liquid component to a patient.
18. The fluid delivery system of claim 1, wherein said patient is a mammalian patient selected from human or non-human animal.
19. The fluid delivery system of claim 1, wherein said infusion set is a needle, a
30 lumen and needle set, a catheter-cannula set, or a microneedle or microneedle array attached by means of one or more lumens.

20. The fluid delivery system of claim 1, wherein said pump is manufactured with inexpensive material for single-use.
21. The fluid delivery system of claim 20, wherein said inexpensive material is latex-free and is suitable for use in latex-intolerant patient.
- 5 22. The fluid delivery system of claim 20, wherein said inexpensive material is disposable or recyclable.
23. The fluid delivery system of claim 20, wherein said inexpensive material is glass or medical grade PVC.
24. The fluid delivery system of claim 1, further comprising a second hydraulic
10 reservoir.
25. The fluid delivery system of claim 24, wherein said second hydraulic reservoir is separately and independently controlled by a second actuator.
26. The fluid delivery system of claim 25, wherein the second hydraulic reservoir and the original reservoir are both connected via a common connective
15 passage and through said aperture to said pump chamber.
27. The fluid delivery system of claim 25, wherein the second hydraulic reservoir is connected to said pump chamber through a second aperture.
28. The fluid delivery system of claim 27, wherein one of the two hydraulic reservoirs is used for sustained delivery of said liquid component, and the
20 other of the two hydraulic reservoir is used for a bolus delivery of said liquid component at predetermined intervals.
29. The fluid delivery system of claim 25, wherein both apertures are independently adjustable.
30. The fluid delivery system of claim 25, wherein one of the two apertures are
25 adjustable.
31. The fluid delivery system of claim 1, wherein said sustained delivery is over a period of: more than 5 hours, more than 24 hours, more than 3 days, or more than one week.
32. The fluid delivery system of claim 1, wherein the viscosity of said hydraulic
30 fluid is about ISO VG 20 or more.
33. A hydraulically actuated pump system comprising:
(1) a pump chamber functionally connected to a moveable barrier;

- (2) a hydraulic fluid reservoir for storing a high viscosity fluid, said reservoir being connected to said pump chamber via an aperture less than 3 μm in diameter, and the largest insoluble particle, if any, in said hydraulic fluid is no more than the size of said aperture; and,
- 5 (3) an actuator functionally connected to said hydraulic fluid reservoir to cause said hydraulic fluid to flow into said pump chamber through said aperture, thereby expanding the volume of said pump chamber, displacing said moveable barrier.
34. A method of administering a medicament, comprising:
- 10 (1) compressing a hydraulic fluid reservoir to force said hydraulic fluid through a connection means;
- (2) passing said hydraulic fluid through an adjustable aperture into a pump chamber, wherein said pump chamber is separated from an adjacent fluid storage chamber by a moveable barrier and wherein
- 15 said fluid storage chamber is filled with a medicament;
- (3) displacing said moveable barrier into said fluid storage chamber by filling said pump chamber with said hydraulic fluid, wherein said displacing causes a quantity of said medicament to be expelled from said fluid storage chamber through an output orifice.
- 20 35. The method of claim 34, wherein said passing is regulated by said adjustable aperture varying the flow of said hydraulic fluid and thus the quantity of said medicament expelled through said orifice.
36. The method of claim 34, further comprising injecting a quantity of said medicament into a patient through an infusion set connected to said orifice.
- 25 37. The method of claim 34, wherein said compressing employs peristaltic compaction of said reservoir at a constant rate.
38. The method of claim 34, wherein said compressing employs peristaltic compaction of said reservoir at a variable rate.
39. The method of claim 34, further comprising rapidly compressing a second
- 30 hydraulic reservoir fluidly connected to said pump chamber to displace said

moveable barrier and thus cause a bolus of said medicament to be expelled through said orifice.

40. The method of claim 39, further comprising passing said hydraulic fluid from said second hydraulic reservoir through a second aperture into said pump chamber.

5

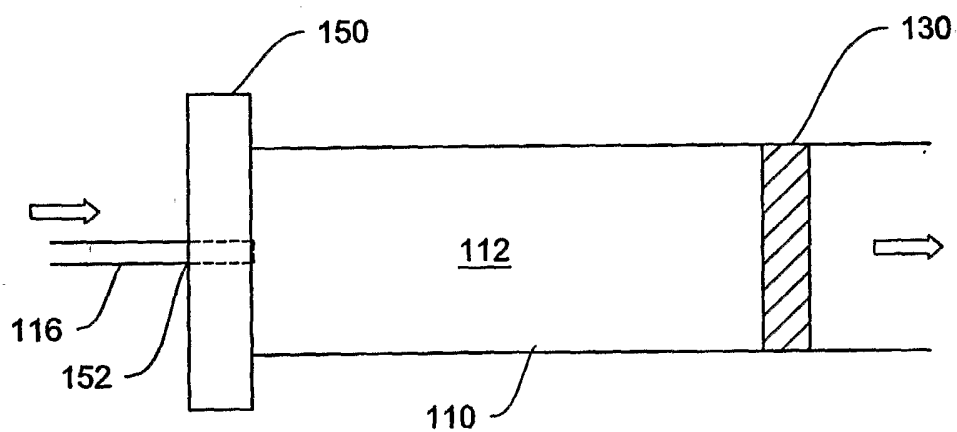

Fig. 1

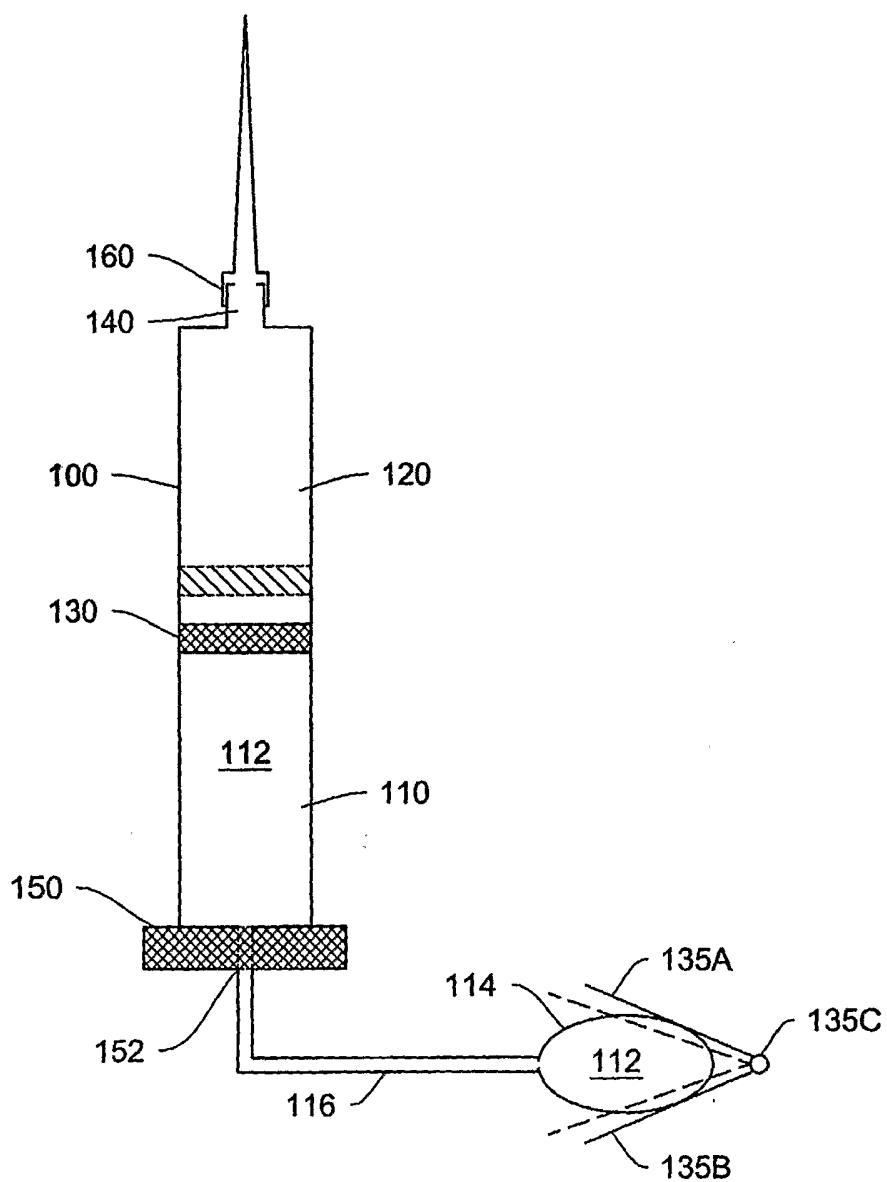

Fig. 2

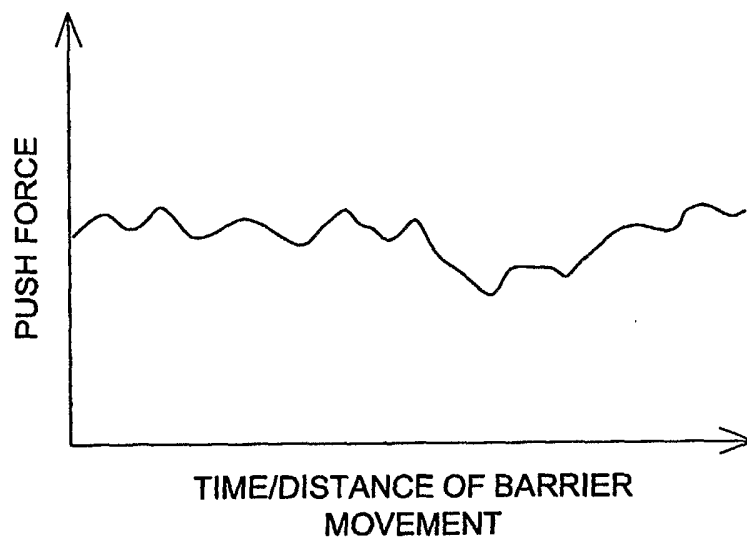

Fig. 3A

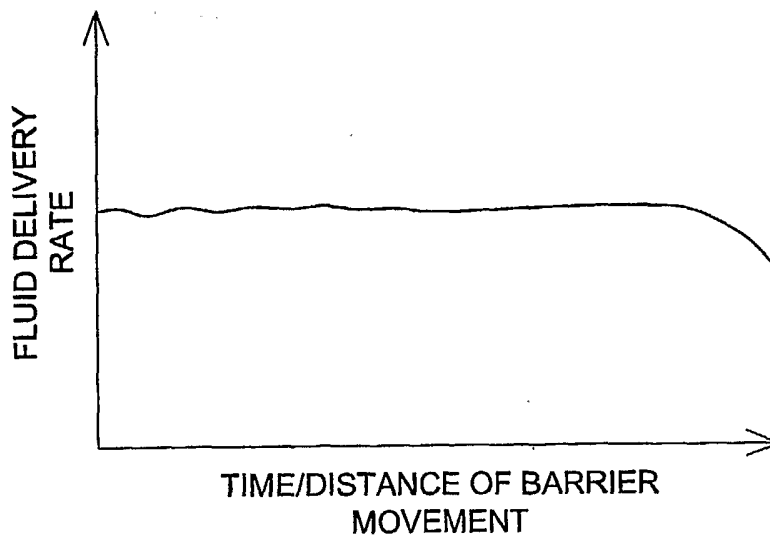

Fig. 3B

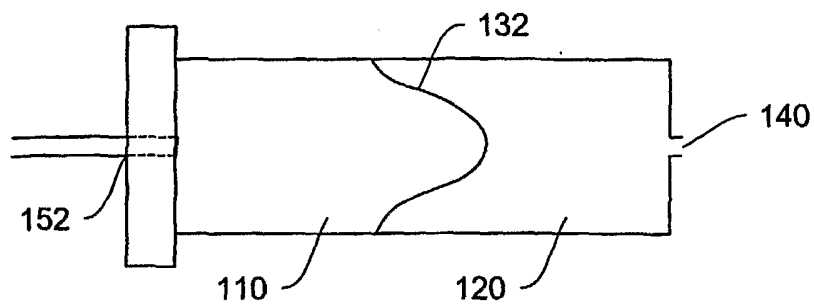

Fig. 4A

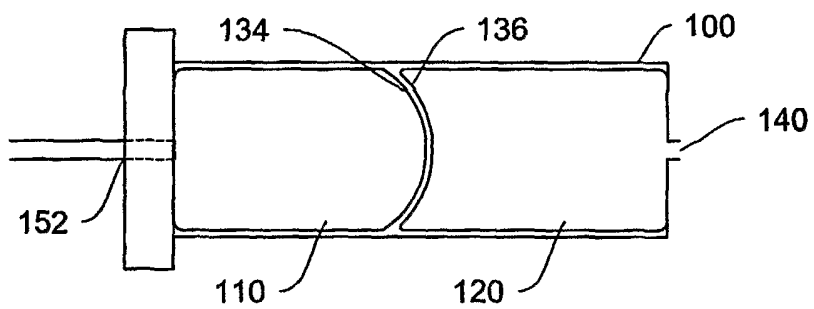

Fig. 4B

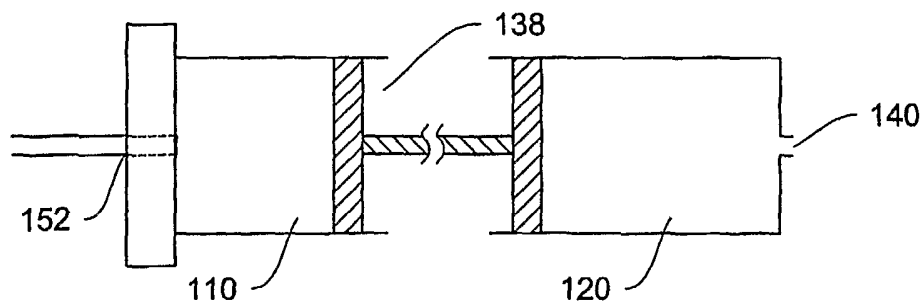

Fig. 4C

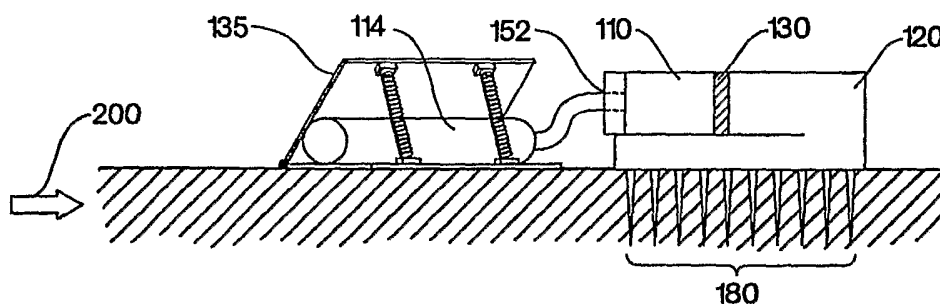

Fig. 5

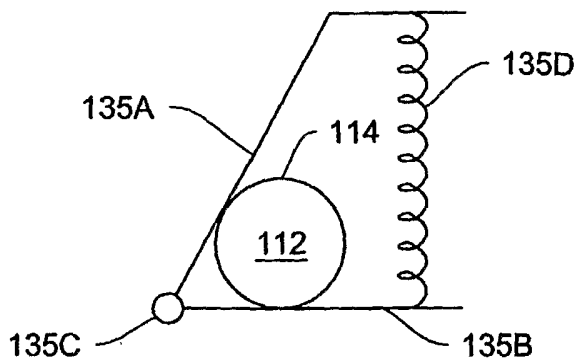

Fig. 6A

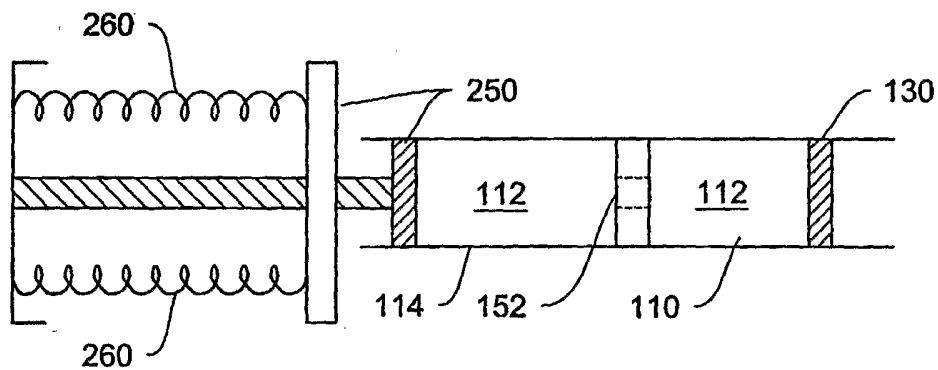

Fig. 6B

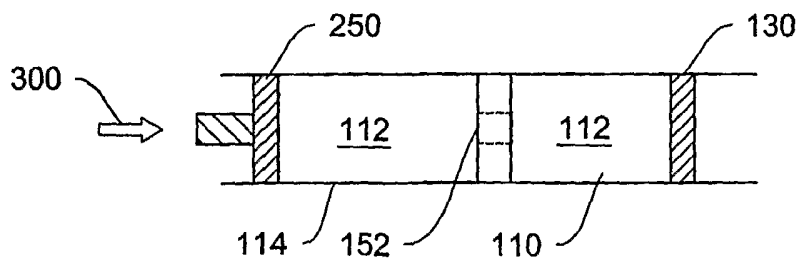

Fig. 6C

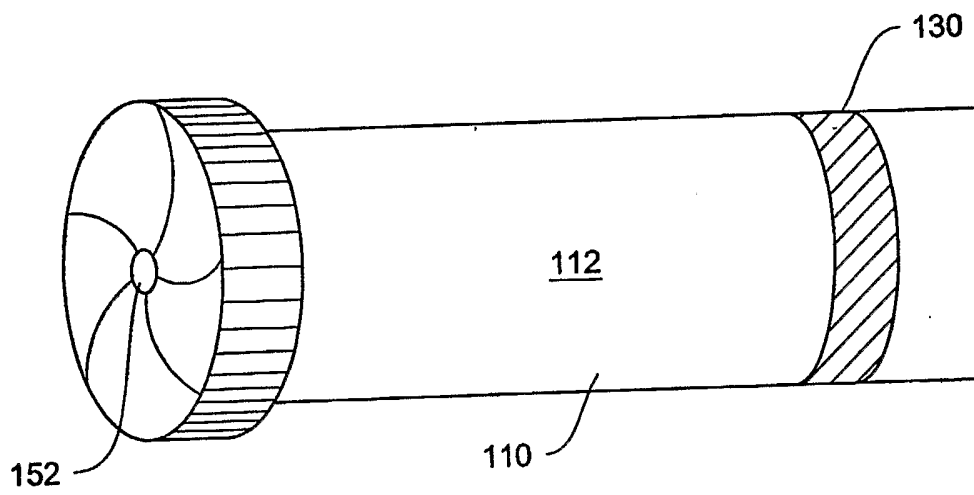

Fig. 7

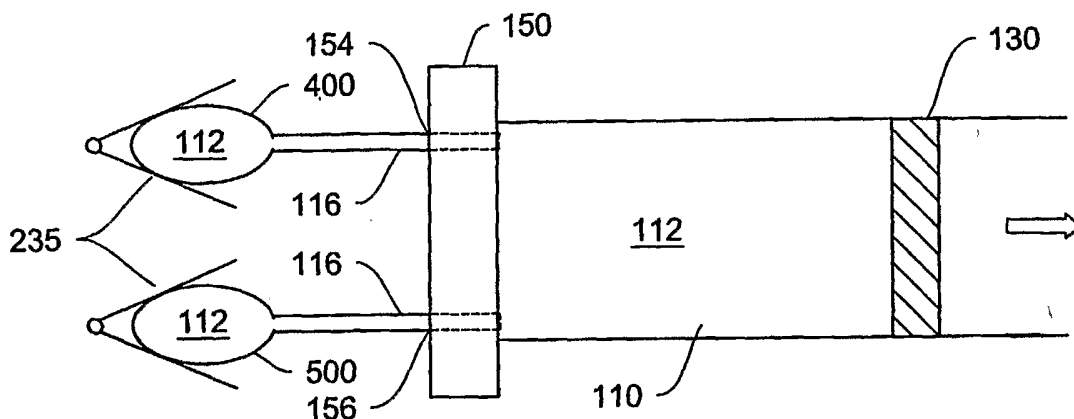

Fig. 8A

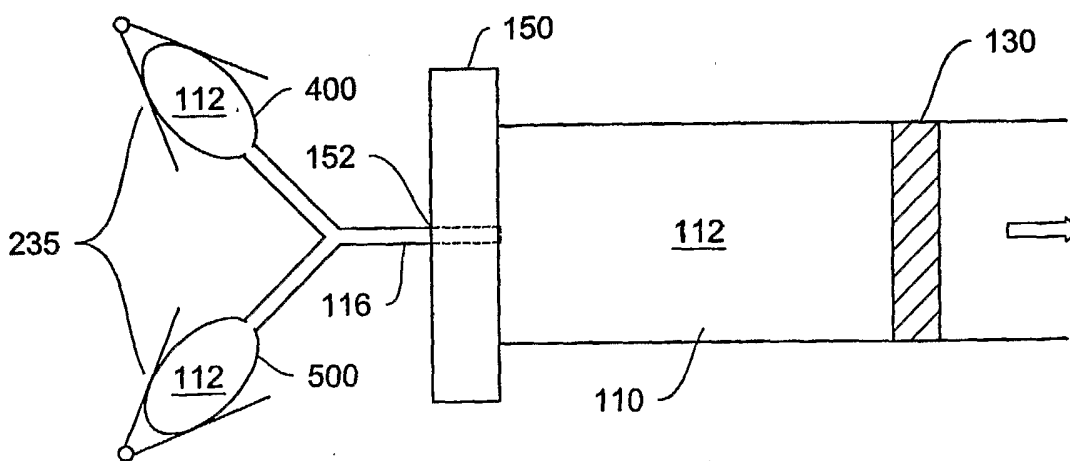

Fig. 8B