

Oifig
Na
bPaitinní
The
Patents
Office

IE 2009/0774

ABSTRACT

The pick up hitch 1 comprises a frame 2 and a towing arm 3 coupled with the frame 2. A hydraulic cylinder 11 having an actuating ram 10 mounted in the interior of the frame 2 and is engaged with the towing arm 3 via a pivot shaft 12. Each free end of the pivot shaft 12 is slidably engaged with the frame 2 via a guide slot 13 formed in each longitudinal side face 2a of the frame. The pick up hitch 1 further comprises a chain 14 and chain take-up and release arrangement to allow the chain take-up and release arrangement to cooperate with the actuating ram 10 so that when the pivot shaft 12 is moved by the actuating ram 10 between first and the second positions in the guide slot 13, the chain 14 is synchronously taken up and released thereby raising and lowering the towing arm 3. <Figure 1>

**TRUE COPY
AS
LODGED**

IE 090774

AN IMPROVED HITCH

The present invention relates to hitches for tractors, and more particularly to pick-up hitches for agricultural tractors.

Pick up hitches of tractors and similarly powered vehicles are typically located between
5 the rear wheels of such vehicles on the aft portion of the chassis. A pick up hitch for an industrial or agricultural vehicle typically comprises a main frame fixedly mounted at a rear portion of the vehicle and a towing arm pivotally connected to the main frame to pivot vertically with respect to the longitudinal axis of the vehicle. The towing arm usually comprises a coupler, e.g. a hook or a ball, for engaging with a towing implement of a
10 trailer. The towing arm can be raised into a towing position wherein the coupler is engaged with the towing implement. The towing arm can also be lowered in order to release the towing implement when desired. In one known pick up hitch the towing arm is movable between the upper engaged and the lower released positions by means of lift-rods coupled between the free end of the towing arm and the tractor and operated by
15 the vehicle's hydraulic or pneumatic system. The disadvantage of this arrangement lies in their relatively complex multi-component structure and the requirement for substantial space to accommodate those components. Furthermore, the visibility of the coupling implement during the coupling manoeuvre is limited.

The object of the present invention is to mitigate and obviate the above problems and to
20 provide an improved trailer pick up hitch having more compact configuration and which is easier to operate.

Accordingly, the present invention provides a pick up hitch comprising:

a frame for mounting to a body of a vehicle and a towing arm coupled with the frame so
25 as to move between a lower released position and an upper trailer engaging position;
each of the frame and the towing arm having a first, trailer facing end and a second, vehicle facing end and a longitudinal axis and the towing arm having a coupling means at the first end for coupling with a towing implement of a trailer;

30 an actuating ram engaged with the towing arm via a pivot means at a location spaced apart from the first end of the towing arm, the pivot means having a pivot axis extending

SEARCHED
INDEXED
JUL No. 250 of 12/10/10

187 CL (2009)
A01B 59/50,
B60D 1/00

substantially laterally transversely with respect to the longitudinal axis of the frame and the pivot means being engaged with the frame via a guide means formed with the frame; the actuating ram being movable on actuation with respect to the frame and the guide means, thereby causing the pivot means to travel along the guide means between a first position, proximal the first end of the frame and a second position distal the first end of the frame;

a chain having first and second ends, a first end of the chain being fastened about the first end of the towing arm at a first anchor point and the chain being engaged with a chain take-up and release means;

the chain take-up and release means being arranged to cooperate with the actuating ram so that when the pivot means is moved by the actuating ram into the first position in the guide means, thereby also shifting the towing arm longitudinally outwardly with respect to the first end of the frame, the chain is synchronously released thereby allowing the towing arm to lower into the released position as it pivots about the pivot axis;

and the chain take-up and release means being further arranged to cooperate with the actuating ram so that when the pivot means is moved by the actuating ram into the second position in the guide means, thereby also shifting the towing arm longitudinally inwardly with respect to the pivot axis, the chain is synchronously taken up thereby raising the towing arm as the towing arm pivots about the pivot axis, so that when the pivot means reaches the second position, the chain is fully taken up and the towing arm assumes the trailer engaging position.

Preferably, the length of the towing arm, the length of the guide means and the angle between the towing arm and the frame when the towing arm is in the lower released position are selected such that in the raised trailer engaging position, the first ends of the frame and the towing arm are substantially aligned, and when the towing arm is in the lower released position, the first end of the towing arm is also substantially aligned with the first end of the frame, or may project longitudinally outwardly with respect to the pivot axis to a pre-determined distance beyond the first end of the frame.

Ideally, the chain take-up and release mechanism is connected with and actuated by the actuation ram.

Due to the arrangement of the pick up hitch provided by the present invention, in use, as the towing arm is pivoted into the lowered position, the first, i.e. the trailer facing end of the towing arm is shifted longitudinally outwardly in the direction away from the vehicle. Thus, in the lowered position, the first end of the towing arm is not offset inwardly
5 towards the vehicle as would be the case in a conventional pick up hitch having a fixed pivot axis. This provides the advantage in that as the driver manoeuvres the vehicle in order to engage the trailer, with the towing arm lowered, the coupling means (e.g. the hook) of the towing arm remains unobstructed by other elements of the hitch and the vehicle and thereby provides for easier and quicker engagement with the trailer
10 implement. Furthermore, the coupling implement remains visible to the driver during the entire manoeuvre thereby facilitating the alignment of the coupling means with the towing implement. On completion of the raising motion of the towing arm, the towing arm is retracted inwardly and the first end of the towing arm is aligned with the first end of the frame. A retaining means may be provided at the first end of the frame for
15 retaining the trailer coupling means in engagement with the trailer implement by cooperating with the coupling means. On retraction of the towing arm, the coupling means of the towing arm is moved sufficiently close to the first end to enable the cooperation between the retaining means and the coupling means. For example, an automatic latching mechanism may be provided on the trailer facing end of the frame
20 which activates upon contact with the coupling means of the towing arm or with the towing implement of the trailer. Due to the provision of the chain and the chain take-up and release means of the invention, a compact, efficient, reliable and space-saving hitch configuration comprising fewer components is achieved. Advantageously, since the chain take up and release mechanism is actuated by the actuating ram, such an
25 arrangement eliminates the need for a separate actuation means for the chain take up and release mechanism. Thus, during a single first stroke of the actuating ram, both the outward shifting of the towing arm and the release of the chain are achieved. Similarly, during a single second stroke of the actuating ram, both the inward shifting and the taking up of the chain are achieved.

30

The length of the guide means determines the length of the longitudinal outward shifting of the first end of the towing arm. Preferably, this length substantially equals the length of a longitudinal inward offset of the first end of the towing arm in a similar pick up hitch but having a fixed pivot axis. Therefore, the length of the guide means, and, as a result,

the length of the longitudinal outward shifting of the first end of the towing arm is preferably substantially less than the actual distance between the first ends of the frame and the towing arm when the towing arm is the lower released position. Therefore, the first end of the towing arm travels a distance longer between the lowered and raised
5 positions than the pivot means between the first and second positions in the guide means.

Accordingly, the length of the chain that needs to be taken up during the lifting of the towing arm is also greater than the length of the guide means.

10 In a most advantageous arrangement, the length of the guide means is half the said actual distance.

In a preferred embodiment, the chain take-up and release means comprises a first pulley member mounted on the frame at a fixed location adjacent the first end of the frame;
a second pulley member rotatably mounted on and movable with the pivot means along
15 the guide means;

and a second anchor point provided on the frame to which second anchor point the second end of the chain is fastened;

wherein the chain is engaged with the first and second pulley members so that the chain is taught between the first and second anchor points;

20 wherein the second anchor point is located on the frame between the location of the first position of the pivot means in the guide means and the first pulley member so that a length of the chain proximal the second end of the chain bends around the second pulley member and extends towards the first end of the frame so that when the pivot means together with the second pulley member travels from the first position into the second
25 position in the guide means, the length of the chain taken up by the second pulley member in cooperation with the second anchor point is double the distance travelled by the pivot means.

When the pivot means reaches the second position in the guide means, the chain is fully taken up and the towing arm assumes the trailer engaging position.

In one embodiment, the second pulley member is rotatably mounted on the pivot means. Such an arrangement takes into account the difference between the length of the guide means and the length of the chain taught between the first end of the towing arm and the first pulley member when the towing arm is in the lower released position and fully takes up the chain when the towing arm is raised. Furthermore, the chain remains taught regardless of the position of the towing arm, be that an end position (i.e. the raised or the lowered position) or an intermediate position.

The use of a chain consisting of a plurality of links for meshing with cogs of a sprocket is preferred as in this way slippage is prevented. However, it will be appreciated that the term "chain" used in the present application also includes belt, cord, cable and the like. Furthermore, the term "pulley member" comprises any known type of pulley and sprocket. The engagement between the "chain" and the "pulley" may be in fact of any known type suitable for this purpose, and includes meshing and friction engagement.

Ideally, the actuating ram comprises a part of a hydraulic or a pneumatic cylinder arrangement, which may be actuated from the respective hydraulic or pneumatic system of the vehicle. In a preferred arrangement, in a first stroke of the actuating ram the pivot means is moved from the first into the second position and in a second stroke the pivot means is moved from the second into the first position.

The pivot means preferably comprises a pivot shaft but the invention is not in any way limited thereto.

In one configuration, the guide means comprises a slot formed in a side wall of the frame in which the pivot means is slidably movable. The use of other known guide means is also possible.

A retaining means, such as for example a recess for receiving a hook of the towing arm, of a spring loaded latch, may be provided at the first of the frame for preventing the trailer implement from disengaging with the trailer coupling means.

The coupling implement may comprise for example a hook for engaging an eye of a trailer implement or a spherical ball for engaging in a recess of corresponding spoon member of a trailer.

Ideally, the position of the first pulley member is substantially aligned with the retaining means along an axis laterally transverse the longitudinal axis.

Ideally, a pair of chains and a pair of corresponding chain take-up and release mechanisms is provided at opposing longitudinal sides of the frame.

The invention will now be described with reference to the accompanying drawings which show by way of example only one embodiment of a pick up hitch according to the invention. In the drawings:

Figure 1 is a perspective view of the pick up hitch of the invention with the towing arm in the lower released mode;

Figure 2 is a side elevation of the pick up hitch of Figure 1;

Figures 3 and 4 are respectively end elevation and top view of the pick up hitch of Figure 1; and

Figure 5 is a perspective view of the pick up hitch of the invention with the towing arm in the upper, trailer engaging mode.

Referring to the drawings a pick up hitch in accordance with the invention is indicated generally by reference numeral 1. The pick up hitch 1 comprises a frame 2 for mounting to a body of a vehicle and a towing arm 3 (sometimes also referred to in the art as a drop-base) coupled with the frame 2 so as to move between a lower, released position (as shown in Figures 1 to 4), and an upper, trailer engaging position (Figure 5).

Each of the towing arm 3 and the frame 2 has a first, trailer facing end 4 and 5, respectively; a second, vehicle facing end 6 and 7, respectively and a longitudinal axis 8 common to the frame 2 and the towing arm 3 when the towing arm 3 in the raised position. The frame 2 comprises a pair of spaced apart opposing longitudinal side faces 2a. The towing arm 3 comprises a pair of spaced apart opposing longitudinal side faces 3a.

In the presently described embodiment, the towing arm 3 has a coupling means in the form of a hook 9 mounted at the first end 5 of the towing arm 3 for coupling with a towing implement of a trailer (not shown). A hydraulic cylinder 11 having an actuating ram 10

(Figures 2 to 4) is mounted in the interior of the frame 2. The hydraulic cylinder 11 is actuated from the hydraulic system of the vehicle (not shown). The actuating ram 10 is engaged with the towing arm 3 via a pivot shaft 12 at the second end 7 of the towing arm 3. The pivot shaft 12 has a pivot axis (not indicated by a numeral) that extends substantially laterally transversely with respect to the longitudinal axis 8 of the frame 2. Each free end of the pivot shaft 12 is slidably engaged with the frame 2 via a guide slot 13 formed in each longitudinal side face 2a of the frame. The actuating ram 10 is movable on actuation by the hydraulic cylinder 11 substantially parallel to the longitudinal axis 8 of the frame 2. On movement of the actuating ram 10 the pivot shaft 12 is caused to travel along the guide slots 13 between a first position (see Figures 1 to 4), proximal the first end 4 of the frame 2 and a second position (see Figure 5) distal the first end of the frame. During a first, outward with respect to the cylinder 11, stroke of the actuating ram 10 the pivot shaft 12 is moved from the first into the second position. During a second, inward with respect to the cylinder 11, stroke of the actuating ram 10 the pivot shaft 12 is moved from the second into the first position.

The pick up hitch 1 further comprises a pair of chains 14 and chain take-up and release means as will be described below. Each chain 14 extends along a respective longitudinal side face 2a of the frame 2 and has first and second ends 15 and 16, respectively. The first end 15 of each chain 14 is fastened at a respective longitudinal side face 3a at the first end 5 of the towing arm 3 at a first anchor point 17. The second end 16 of each chain 14 is fastened at a respective longitudinal side face 2a of the frame 2 at a second anchor point 18 provided on the frame 3. A first pulley 19 is mounted on each longitudinal side face of the frame 2 at a fixed location adjacent the first end 4 of the frame 2. A second pulley 20 is mounted at each free end of the pivot shaft 12 so as to be movable with the pivot shaft 12 along the guide slots 13. Each chain 14 is engaged with the respective first and second pulleys 19, 20 so as to be taught between the respective first and second anchor points 17, 18. Each second anchor point 18 is located on the frame 2 between the location of first position of the pivot shaft 12 in the guide slots 13 and the first pulley 19 so that a length of each chain 14 proximal the second end 16 of the chain 14 bends around the second pulley 20 and extends towards the first end 4 of the frame 2.

Due to the above arrangement, when the pivot shaft 12 together with the second pulley 20 travels from the first position into the second position in the guide slots 13, the length

of each chain 14 taken up by the second pulley 20 in cooperation with the second anchor point 18 is double the distance travelled by the pivot shaft 12. When the pivot shaft 12 reaches the second position in the guide slots 13, the chains 14 are fully taken up and the towing arm 3 assumes the upper, trailer engaging position as shown in
5 Figure 5. This arrangement takes into account the difference between the length of the guide slot and the length of the chains 14 between the first end 5 of the towing arm 3 and the first pulley 19 when the towing arm 3 is in the lower released position. When the towing arm 3 is raised, the chains 14 are fully taken up. The chains 14 remain taught regardless of the vertical position of the towing arm 3, be that an end position (i.e. the
10 raised or the lowered position) or an intermediate position.

When the pivot shaft 12 is moved by the actuating ram 10 into the first position in the guide slots 13, the towing arm 3 is shifted longitudinally outwardly with respect to the first end 4 of the frame 2, the chains 14 are synchronously released thereby allowing the towing arm 3 to lower into the released position (Figures 1 to 4) as it pivots about the
15 pivot axis of the pivot shaft 12. When the pivot shaft 12 is moved by the actuating ram 10 into the second position in the guide slots 13, the towing arm 3 is shifted longitudinally inwardly with respect to the first end 4 of the frame 2, the chains 14 are synchronously taken up thereby raising the towing arm 3 as described above. Thus, during a single first stroke of the actuating ram 10, both the outward shifting of the towing arm 3 and the
20 release of the chains 14 are achieved. Similarly, during a single second stroke of the actuating ram 10, both the inward shifting of the towing arm 3 and the taking up of the chains 14 are achieved.

The length of the towing arm 3, the length of the guide slots 13 and the angle between the towing arm 3 and the frame 2 when the towing arm 3 is in the lower released position
25 are selected such that in the raised trailer engaging position, the first ends 4, 5 of the frame 2 and the towing arm 3 are substantially aligned (Figure 5). When the towing arm 3 is in the lower released position the first 5 end of the towing arm 3 projects longitudinally outwardly with respect to the first end 4 of the frame 2 to a pre-determined distance beyond the first end 4 of the frame 2. The above parameters may of course be
30 selected so that in the lower released position the first 5 end of the towing arm 3 aligned with the first end 4 of the frame 2.

Thus, in the lowered position, the first end 5 of the towing arm 3 is not offset inwardly towards the vehicle as would be the case in a conventional pick up hitch having a fixed pivot axis. On completion of the raising motion of the towing arm 3, the towing arm 3 is retracted inwardly and the first end 5 of the towing arm 3 is aligned with the first end 4 of the frame 2.

The length of the guide slots 13 determines the length of the longitudinal outward shifting of the first end 5 of the towing arm 3. This length substantially equals the length of a longitudinal inward offset of the first end of the towing arm in a similar pick up hitch but having a fixed pivot axis. Therefore, the length of the guide slots 13, and, as a result, the length of the longitudinal outward shifting of the first end 5 of the towing arm 3 is substantially less than the actual distance between the first ends 4, 5 respectively of the frame 2 and the towing arm 3 when the towing arm is the lower released position.

Therefore, the first end 5 of the towing arm 3 travels a greater distance between the lowered and raised positions than the pivot shaft 12 between the first and second positions in the guide slots 13. Accordingly, the length of the chains 14 that needs to be taken up during the lifting of the towing arm 3 is also greater than the length of the guide slots 13. In the presently described embodiment, the length of the guide slots 13 is half the said actual distance travelled vertically by the first end 5 of the towing arm 3.

Bracket 22 is provided at the first end 4 of the frame 2 for engaging with and retaining the hook 9 in engagement with the trailer implement. On retraction of the towing arm 3, the hook 9 is moved sufficiently close to the first end 4 of the frame 2 so as to engage the bracket 22.

Rotatably mounted sprockets (not shown) may be employed instead of the pulleys 19, 20.

It will be appreciated by those skilled in the art that variations and modification can be made without departing from the scope of the invention as defined in the appended claims.

IE 090774

CLAIMS

1. A pick up hitch comprising a frame for mounting to a body of a vehicle and a towing arm coupled with the frame and being movable between a lower released position and
5 an upper trailer engaging position, each of the frame and the towing arm having a first, trailer facing end and a second, vehicle facing end and a longitudinal axis and the towing arm having a coupling means at the first end for coupling with a towing implement of a trailer, an actuating ram engaged with the towing arm via a pivot means at a location spaced apart from the first end of the towing arm, the pivot means having a pivot axis
10 extending substantially laterally transversely with respect to the longitudinal axis of the frame and the pivot means being engaged with the frame via a guide means formed with the frame, the actuating ram being movable on actuation with respect to the frame and the guide means for causing the pivot means to travel along the guide means between a first position, proximal the first end of the frame and a second position distal the first end
15 of the frame, a chain having first and second ends, a first end of the chain being fastened about the first end of the towing arm at a first anchor point and the chain being engaged with a chain take-up and release means, the chain take-up and release means being arranged to cooperate with the actuating ram so that when the pivot means is moved by the actuating ram into the first position in the guide means, thereby also
20 shifting the towing arm longitudinally outwardly with respect to the first end of the frame, the chain is synchronously released thereby allowing the towing arm to lower into the released position as it pivots about the pivot axis and the chain take-up and release means being further arranged to cooperate with the actuating ram so that when the pivot means is moved by the actuating ram into the second position in the guide means,
25 thereby also shifting the towing arm longitudinally inwardly with respect to the pivot axis, the chain is synchronously taken up thereby raising the towing arm as the towing arm pivots about the pivot axis, so that when the pivot means reaches the second position, the chain is fully taken up and the towing arm assumes the trailer engaging position.

2. A pick-up hitch as claimed in claim 1, wherein the length of the towing arm, the length
30 of the guide means and the angle between the towing arm and the frame when the towing arm is in the lower released position are selected such that in the raised trailer engaging position, the first ends of the frame and the towing arm are substantially aligned, and when the towing arm is in the lower released position, the first end of the

IE 090774

towing arm is also substantially aligned with the first end of the frame or projects longitudinally outwardly with respect to the pivot axis to a pre-determined distance beyond the first end of the frame.

3. A pick-up hitch as claimed in claim 1 or claim 2, wherein the chain take-up and
5 release means is connected with and actuated by the actuation ram.

4. A pick-up hitch as claimed in any one of the preceding claims, wherein a retaining means is provided at the first end of the frame for retaining the coupling means in engagement with a towed implement by cooperating with the coupling means.

10

5. A pick-up hitch as claimed in any one of the preceding claims, wherein the length of the guide means and the length of the longitudinal outward shifting of the first end of the towing arm is substantially less than the actual distance between the first ends of the frame and the towing arm when the towing arm is the lower released position.

15

6. A pick-up hitch as claimed in any one of the preceding claims, wherein the length of the chain to be taken up during the lifting of the towing arm is greater than the length of the guide means.

20

7. A pick-up hitch as claimed in any one of the preceding claims, wherein the length of the chain to be taken up during the lifting of the towing arm is twice the length of the guide means.

25

8. A pick-up hitch as claimed in any one of the preceding claims, wherein the chain take-up and release means comprises a first pulley member mounted on the frame at a fixed location adjacent the first end of the frame;

a second pulley member rotatably mounted on and movable with the pivot means along the guide means;

30

and a second anchor point provided on the frame to which second anchor point the second end of the chain is fastened;

wherein the chain is engaged with the first and second pulley members so that the chain is taught between the first and second anchor points;

wherein the second anchor point is located on the frame between the location of the first position of the pivot means in the guide means and the first pulley member so that a length of the chain proximal the second end of the chain bends around the second pulley member and extends towards the first end of the frame so that when the pivot means
5 together with the second pulley member travels from the first position into the second position in the guide means, the length of the chain taken up by the second pulley member in cooperation with the second anchor point is greater than the distance travelled by the pivot means.

9. A pick-up hitch as claimed in claim 8, wherein the second pulley member is rotatably
10 mounted on the pivot means.

10. A pick-up hitch as claimed in any preceding claim, wherein the chain consists of a plurality of links for meshing with cogs of a sprocket.

11. A pick-up hitch as claimed in any preceding claim, wherein the actuating ram comprises a part of a hydraulic or a pneumatic cylinder arrangement actuatable from the
15 respective hydraulic or pneumatic system of the vehicle.

12. A pick-up hitch as claimed in any preceding claim, wherein the pivot means comprises a pivot shaft.

13. A pick-up hitch as claimed in any preceding claim, wherein the guide means comprises a slot formed in a side wall of the frame in which the pivot means is slidably
20 movable.

14. A pick-up hitch as claimed in any preceding claim, wherein a pair of chains and a pair of corresponding chain take-up and release mechanisms are provided at opposing longitudinal sides of the frame.

15. A pick-up hitch substantially as hereinbefore described with reference to and as
25 shown in the accompanying drawings.

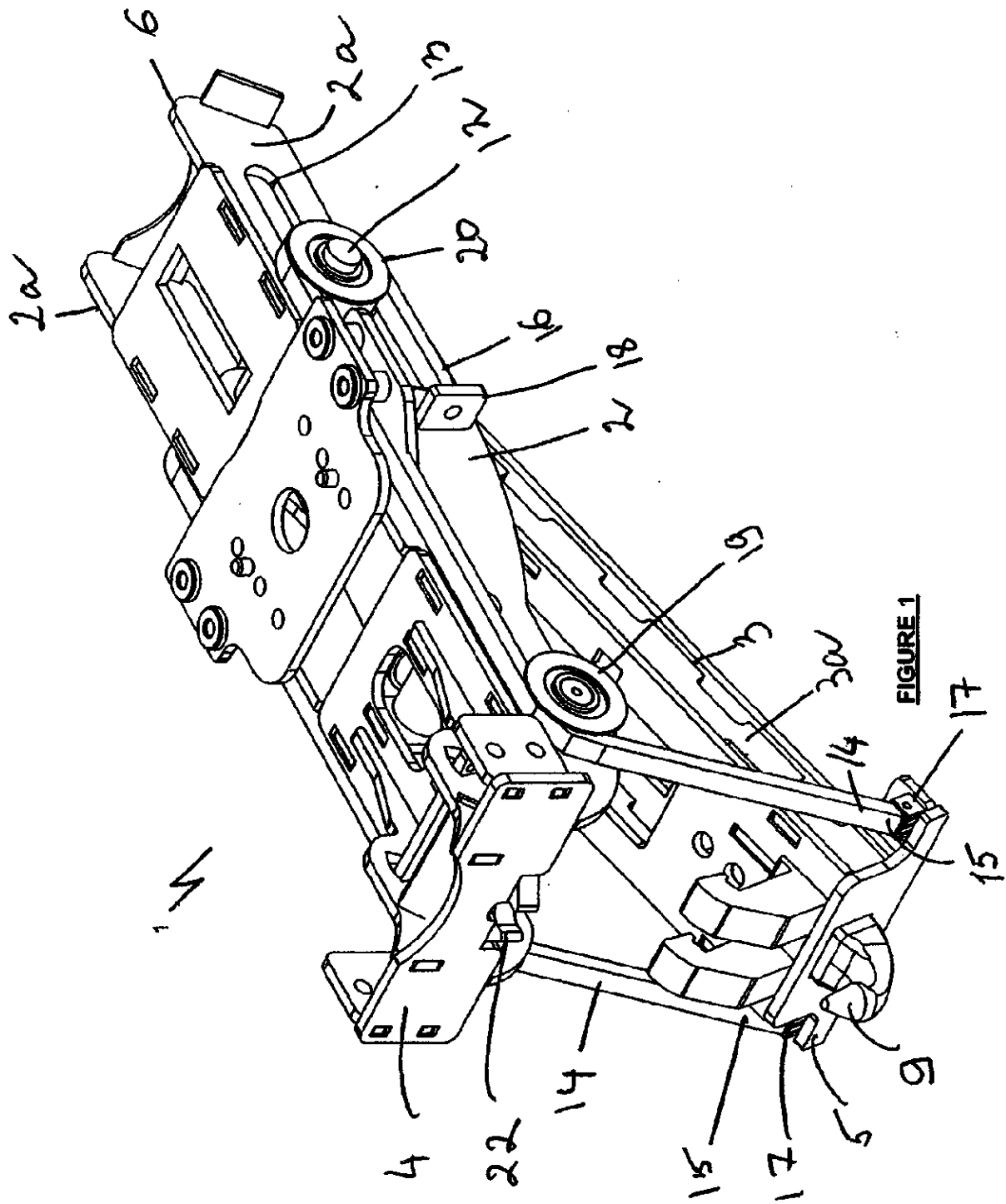

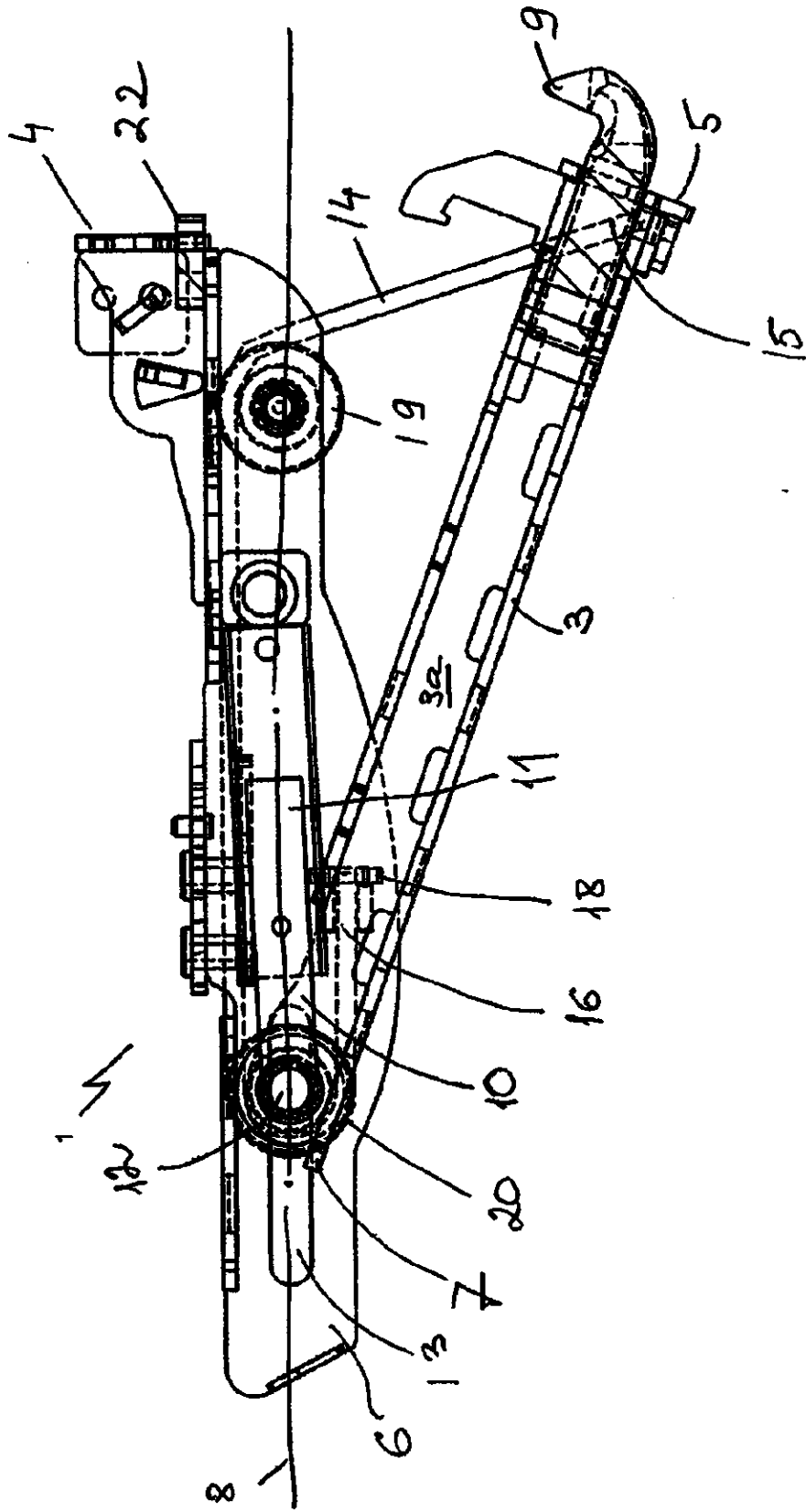

FIGURE 2

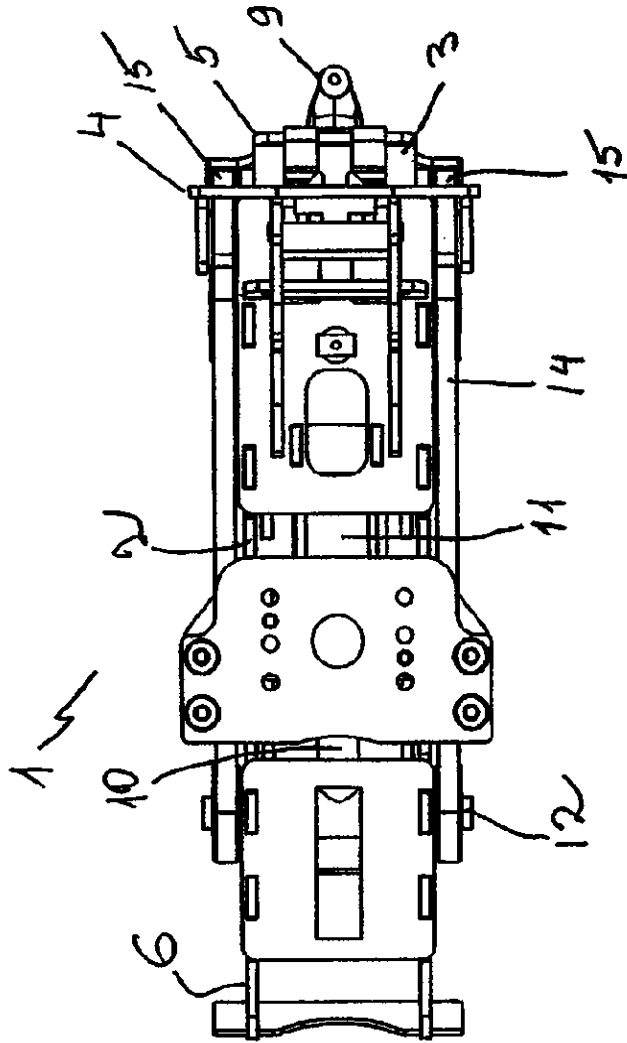

FIGURE 4

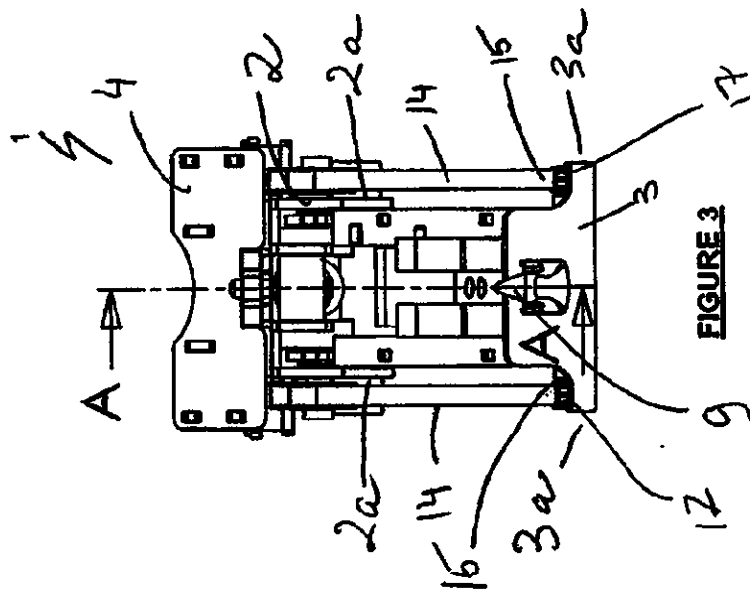

FIGURE 3

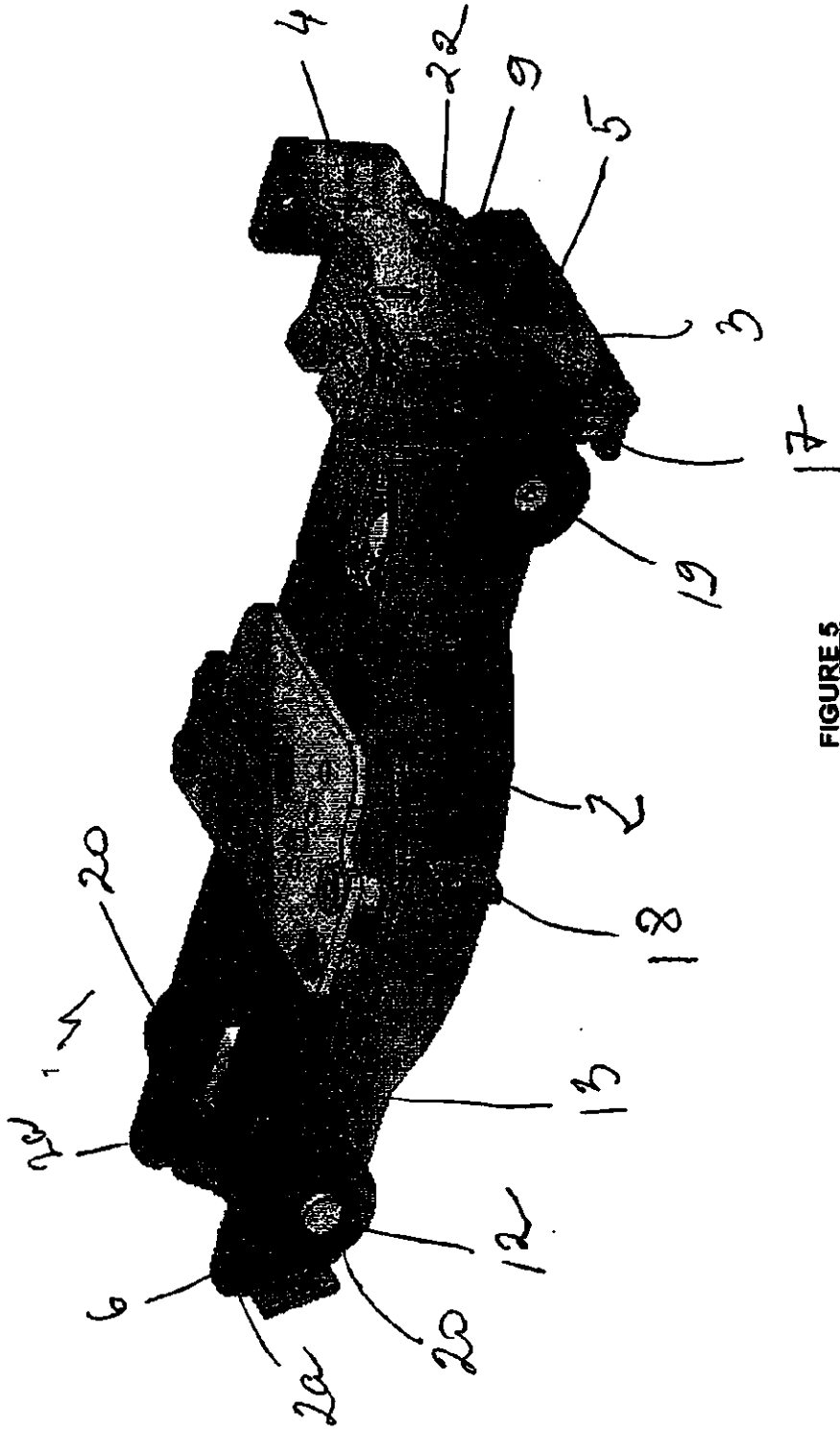

FIGURE 5