

(19) World Intellectual Property Organization
International Bureau



(43) International Publication Date
9 February 2006 (09.02.2006)

PCT

(10) International Publication Number
WO 2006/015138 A1

- (51) International Patent Classification⁷: **A61F 13/15**
- (21) International Application Number: PCT/US2005/026831
- (22) International Filing Date: 28 July 2005 (28.07.2005)
- (25) Filing Language: English
- (26) Publication Language: English
- (30) Priority Data: 04017789.1 28 July 2004 (28.07.2004) EP
- (71) Applicant (for all designated States except US): **THE PROCTER & GAMBLE COMPANY** [US/US]; One Procter & Gamble Plaza, Cincinnati, Ohio 45202 (US).
- (72) Inventors; and
- (75) Inventors/Applicants (for US only): **BLESSING, Horst** [DE/DE]; Arkturstr. 7, 53881 Euskirchen (DE). **JACK-ELS, Hans-Adolf** [DE/DE]; Kirchforst 16, 53894 Mechernich (DE). **RIETZ, Markus** [DE/DE]; Marathonstrasse 19, 53881 Euskirchen (DE).
- (74) Common Representative: **REED, David, T.**; The Procter & Gamble Company, Winton Hill Business Center, 6110 Center Hill Road, Cincinnati, OH 45224 (US).
- (81) Designated States (unless otherwise indicated, for every kind of national protection available): AE, AG, AL, AM, AT, AU, AZ, BA, BB, BG, BR, BW, BY, BZ, CA, CH, CN, CO, CR, CU, CZ, DE, DK, DM, DZ, EC, EE, EG, ES, FI, GB, GD, GE, GH, GM, HR, HU, ID, IL, IN, IS, JP, KE, KG, KM, KP, KR, KZ, LC, LK, LR, LS, LT, LU, LV, MA, MD, MG, MK, MN, MW, MX, MZ, NA, NG, NI, NO, NZ, OM, PG, PH, PL, PT, RO, RU, SC, SD, SE, SG, SK, SL, SM, SY, TJ, TM, TN, TR, TT, TZ, UA, UG, US, UZ, VC, VN, YU, ZA, ZM, ZW.
- (84) Designated States (unless otherwise indicated, for every kind of regional protection available): ARIPO (BW, GH, GM, KE, LS, MW, MZ, NA, SD, SL, SZ, TZ, UG, ZM, ZW), Eurasian (AM, AZ, BY, KG, KZ, MD, RU, TJ, TM), European (AT, BE, BG, CH, CY, CZ, DE, DK, EE, ES, FI, FR, GB, GR, HU, IE, IS, IT, LT, LU, LV, MC, NL, PL, PT,

[Continued on next page]

(54) Title: PROCESS FOR PRODUCING ABSORBENT CORE STRUCTURES

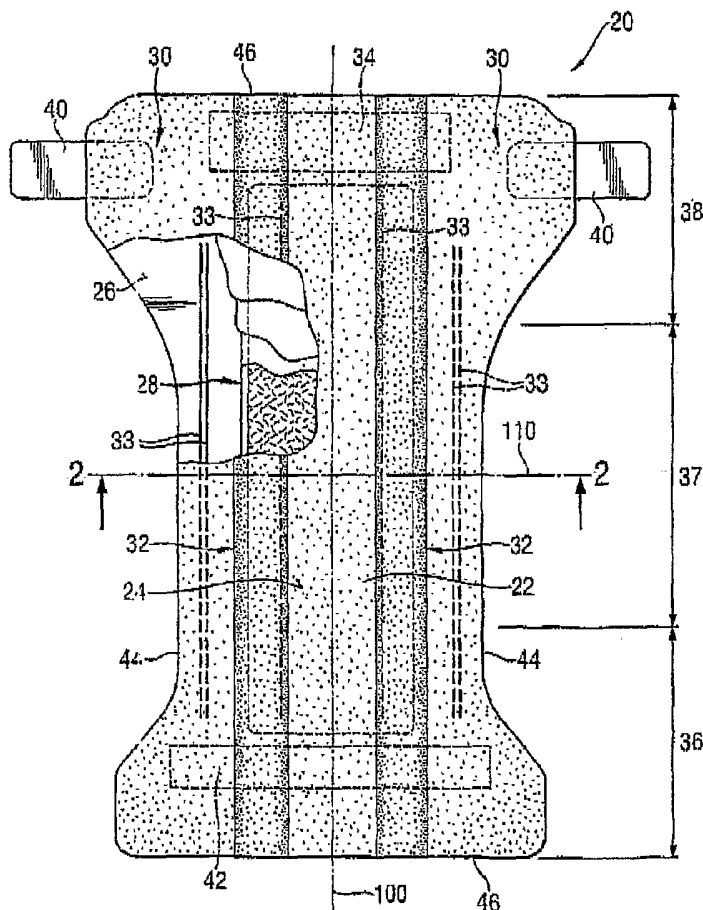

(57) Abstract: The present invention is method for forming a sandwich structure having a pattern of particulate material enveloped between a carrier material and a cover material. The method allows accurate forming of pre-determined pattern at high production speed. Such a method is particularly useful in the manufacture of disposable absorbent articles, such as baby diapers.

WO 2006/015138 A1



RO, SE, SI, SK, TR), OAPI (BF, BJ, CF, CG, CI, CM, GA, GN, GQ, GW, ML, MR, NE, SN, TD, TG).

For two-letter codes and other abbreviations, refer to the "Guidance Notes on Codes and Abbreviations" appearing at the beginning of each regular issue of the PCT Gazette.

Published:

— *with international search report*

Process for producing absorbent core structures

Field of the invention

- 5 The present invention is a process for forming a sandwich structure having a pattern of particulate material enveloped between a carrier and a cover material. In a particular embodiment, the particulate material is super absorbent material, and the sandwich structure is a liquid absorbent structure for use in disposable absorbent products.

Background

- 10 Composite structures comprising particulate material in a particular pattern are well known in the art, see, e.g. EP-1447066 (Busam et al.; P&G), disclosing an absorbent core for an absorbent article, which has a particulate absorbent material that is immobilized when wet. The absorbent core comprises a substrate layer with an absorbent material, such as an absorbent polymer material.

- 15 US 4 381 783 (Elias) discloses an absorbent article with a core comprising pockets of absorbent hydrocolloid material. These pockets are provided to confine the movement of absorbent polymer material, in particular when the article is fully or partially loaded with urine. The pockets form part of an absorbent layer and are typically provided from cellulose material. Hence, as to achieve good immobilization of the absorbent polymer material according to the teaching of this patent
- 20 relatively high amount of cellulosic material is required. Moreover, the provision of such pockets may hinder the free distribution of liquid to the more absorbent areas of the core, for example the areas of the absorbent polymer materials.

- Accordingly, processes to produce absorbent article having a non-homogeneous distribution of absorbent materials such as particulate absorbent polymer material, often referred to as absorbent
- 25 gelling material or as superabsorbent, are also well known. In WO 03/101622A2 (Tombült et al.; P&G) a pulsing process for creating discontinuous particulate distribution is disclosed, and a similar structure may be produced according to US 5213817 (Pelley; McNeill PPC).

- Processes aiming at depositing a pattern of particulate absorbent material onto a web are described in US 4800102 (Takada; Nordson), employing a rotating mask, or in WO 92/019198A
- 30 (Perneborn / Mølnlycke) showing a linearly moving mask. FR-A-2583377 (Piron; Colgate Palmolive) discloses a metering drum into which absorbent powder is fed from a hopper for creating discontinuous pattern on a carrier on a conveyor belt. The drum is operated in a step-wise movement.

- US-5494622 (Heath et al.; K-C), aims at producing pockets of particles in a desired pattern on a
- 35 web moving at high speed. A pattern chamber is supplied with particles of high absorbency

material through which a gas permeable web is transported on a surface having a pattern of openings through which a vacuum is drawn so as to cause the particles to be deposited on the web in the pattern of the openings in the surface. The web carrying the particles is covered by a layer of liquid permeable material or the tension applied to the permeable web is varied to vary the porosity of the web. The particles are held on the web in the desired pattern of pockets while surplus particles between the pockets are removed. The thusly formed pockets form "islands", i.e. they are completely surrounded by bonded regions.

Whilst such documents describe various approaches to the deposition of particulate material onto a surface or on a moving substrate, there is still the need for a method to produce patterned particulate sandwiches in a very well defined pattern and at high production speeds.

Summary

The present invention is a process of creating a sandwich structure comprising particulate material sandwiched between web materials in a very well defined pattern.

The method comprises the step of providing an essentially flat carrier material and an essentially flat cover material for forming the outer sandwich layers, which may be unitary for forming both outer sandwich layers, or which may be different materials forming the outer sandwich layers. Further steps provide an essentially endless support means for the carrier material having a support pattern and a carrier material holding means. The carrier material is positioned over the support means at a carrier speed relative to a fixed frame, whereby the carrier means contacts the support pattern with its support surface and whereby the relative speed between carrier material and the contact surface of the carrier support means is essentially zero. A particulate material is provided and pre-metered. The cover material and the carrier material are combined and affixed by a fixation means with the particulate material positioned there between. The carrier material is supported only in the region of the support pattern of the support means and deformed by a carrier holding means such that indentations are formed in the unsupported regions. The particulate material is transferred to the carrier material into the indentations; thereby forming a primary pattern of particulate material.

In preferred executions, the carrier material is a non-woven material, preferably of the SMS or SMMS type, and it may have a CD-extensibility or a MD-extensibility of more the 20 %, preferably more than 100 %, but even more preferably not more than 200 %. The ratio of MD-extensibility to the CD-extensibility is at a given load not more than one to two. Also the cover material can be a non-woven material, optionally being the same material as the carrier material.

The particulate material can be a bulk material, preferably a superabsorbent, more preferably a partially cross-linked polyacrylate material.

In a preferred execution, the carrier support means is a rotatable drum, preferably having an outer cylinder shell. It is further preferred, that the carrier holdings means is a vacuum air suction.

The carrier support pattern may comprise support pins, which may have a distance of more than 5 mm and not more than 30 mm from each neighboring support pins. The support pins preferably
5 have an outwardly extending surface of at least 0.8 mm², preferably of at least 4 mm², but not more than 170 mm², preferably not more than 80 mm².

The sandwich fixation means is preferably thermo-bonding or glue-bonding, more preferably a sprayed adhesive. The bonding region is at least 2 %, preferably at least 7 %, but more preferably not more than 50 % of the area of the pattern area. Preferably, the bonding region comprises
10 essentially no particulate material, as assessed by the method for determining the absence of particles in the bonding area.

The carrier holding means extends the carrier material such that it deforms out of the original flat state forming an indentation. Preferably, the indentations have a volume of more than 30 mm³, preferably more than 100 mm³, but less than about 1000 mm³. Preferably, the particulate material
15 fills more than 5 % of the volume of the indentations, preferably not more than 150 % of the volume of the indentations.

Brief description of the Figures

- Fig. 1 is a top plan view of a disposable diaper, with the upper layers partially cut away.
20 Fig. 2 shows a cross-sectional view of the disposable diaper of Fig. 1.
Fig. 3A shows a top view of an absorbent core sandwich structure.
Fig. 3B is a cross-sectional view of the sandwich pattern of Fig. 3A.
Fig. 4A is a schematic process diagram for forming a sandwich structure.
Fig. 4B is a schematic enlarged sectional view of a part of the equipment for the process as shown
25 in Fig. 4A.
Fig. 5A is a schematic perspective presentation of the shell of a carrier support means.
Fig. 5B is a schematic cross-sectional view of the shell of Fig. 5A.
Fig. 5C is a schematic top view of a part of the shell of Fig. 5A and B.
Fig. 6 A, C, E, and G show various embodiments of a carrier support means, and Fig. 6 B, D, F, H
30 corresponding cross-sectional views.

Detailed description

The present invention aims at producing a patterned sandwich structure, which contains
35 particulate material being sandwiched between a carrier material in a very well defined amount

and pattern. Such structures are particularly useful for disposable absorbent articles. Such articles have very varying requirements as to the desired absorbency depending on the intended use.

As used herein, the following terms have the following meanings:

"Absorbent article" refers to devices that absorb and contain liquid, and more specifically, refers to devices that are placed against or in proximity to the body of the wearer to absorb and contain the various exudates discharged from the body. Absorbent articles include but are not limited to
5 diapers, adult incontinence briefs, training pants, diaper holders and liners, sanitary napkins and the like.

"Diaper" refers to an absorbent article generally worn by infants and incontinent persons about the
10 lower torso.

"Disposable" is used herein to describe articles that are generally not intended to be laundered or otherwise restored or reused (i.e., they are intended to be discarded after a single use and, preferably, to be recycled, composted or otherwise disposed of in an environmentally compatible manner).

"Comprise," "comprising," and "comprises" is an open ended term that specifies the presence of what follows e.g. a component but does not preclude the presents of other features, elements, steps or components known in the art, or disclosed herein.
15

The term "web material" refers to an essentially endless material in one direction, i.e. the longitudinal extension, or the length, or the x-direction in Cartesian coordinates relative to the web material. Included in this term is an essentially unlimited sequence of pieces cut or otherwise separated from an essentially endless material. Often, though not necessarily, the web materials will have a thickness dimension (i.e. the z-direction) which is significantly smaller than the longitudinal extension (i.e. in x-direction). Typically, the width of web materials (the y-direction) will be significantly larger than the thickness, but less than the length. Often, though not
20 necessarily, the thickness and the width of such materials is essentially constant along the length of the web. Without intending any limitation, such web materials may be cellulosic fiber materials, tissues, woven or non-woven materials and the like. Typically, though not necessarily, web materials are supplied in roll form, or on spools, or in a folded state in boxes. The individual deliveries may then be spliced together to form the essentially endless structure. A web material
25 may be composed of several web materials, such as multilayer non-woven, coated tissues, non-woven / film laminates. Web materials may comprise other materials, such as added binding material, particles, hydrophilizing agents and the like.
30

The terms "superabsorbent", "super absorbent material" or "SAM", "absorbent gelling material" or "AGM", "absorbent polymer material" are used herein interchangeably, and refer to partially
35 cross-linked polymeric materials, which can absorb water whilst they are swelling to form a gel.

All patents and patent applications (including any patents which issue thereon) assigned to the Procter & Gamble Company referred to herein, are hereby incorporated by reference to the extent that it is consistent herewith.

5 An exemplary absorbent structure is depicted in Figures 1 and 2. Figure 1 is a plan view of a diaper 20 as a preferred embodiment of an absorbent article according to the present invention. The diaper is shown in its flat out, uncontracted state (i.e., without elastic induced contraction). Portions of the structure are cut away to more clearly show the underlying structure of the diaper 20. The portion of the diaper 20 that contacts a wearer is facing the viewer. The chassis 22 of the
10 diaper 20 in Figure 1 comprises the main body of the diaper 20. The chassis 22 comprises an outer covering including a liquid pervious topsheet 24 and/or a liquid impervious backsheet 26. The chassis may include a portion of an absorbent core 28 encased between the topsheet 24 and the backsheet 26. The chassis may also include most or all of the absorbent core 28 encased between the topsheet 24 and the backsheet 26. The chassis preferably further includes side panels
15 30, elasticized leg cuffs 32, and elastic waist feature 34, the leg cuffs 32 and the elastic waist feature each typically comprise elastic members 33. One end portion of the diaper 20 is configured as a first waist region 36 of the diaper 20. The opposite end portion is configured as a second waist region 38 of the diaper 20. An intermediate portion of the diaper 20 is configured as a crotch region 37, which extends longitudinally between the first and second waist regions 36
20 and 38. The waist regions 36 and 38 may include elastic elements such that they gather about the waist of the wearer to provide improved fit and containment (elastic waist feature 34). The crotch region 37 is that portion of the diaper 20 which, when the diaper 20 is worn, is generally positioned between the wearer's legs. The diaper 20 is depicted with its longitudinal axis 100 and its transverse axis 110. The periphery of the diaper 20 is defined by the outer edges of the diaper
25 20 in which the longitudinal edges 44 run generally parallel to the longitudinal axis 100 of the diaper 20 and the end edges 46 run between the longitudinal edges 44 generally parallel to the transverse axis 110 of the diaper 20. The chassis also comprises a fastening system, which may include at least one fastening member 40 and at least one landing zone 42.

For unitary absorbent articles, the chassis 22 comprises the main structure of the diaper with other
30 features added to form the composite diaper structure. While the topsheet 24, the backsheet 26, and the absorbent core 28 may be assembled in a variety of well-known configurations, preferred diaper configurations are described generally in U.S. Pat. No. 5,554,145 entitled "Absorbent Article With Multiple Zone Structural Elastic-Like Film Web Extensible Waist Feature" issued to Roe et al. on September 10, 1996; U.S. Pat. No. 5,569,234 entitled "Disposable Pull-On Pant" issued to Buell et al. on October 29, 1996; and U.S. Patent No. 6,004,306 entitled "Absorbent
35

Article With Multi-Directional Extensible Side Panels" issued to Robles et al. on December 21, 1999.

The topsheet 24 in Figures 1 and 2 may be fully or partially elasticized or may be foreshortened to provide a void space between the topsheet 24 and the absorbent core 28. Exemplary structures including elasticized or foreshortened topsheets are described in more detail in U.S. Pat. No. 5,037,416 entitled "Disposable Absorbent Article Having Elastically Extensible Topsheet" issued to Allen et al. on August 6, 1991; and U.S. Pat. No. 5,269,775 entitled "Trisection Topsheets for Disposable Absorbent Articles and Disposable Absorbent Articles Having Such Trisection Topsheets" issued to Freeland et al. on December 14, 1993.

10 The absorbent core 28 in Figure 1 generally is disposed between the topsheet 24 and the backsheet 26. In addition to the absorbent sandwich structure as described herein below, the absorbent core 28 may comprise any absorbent material that is generally compressible, conformable, non-irritating to the wearer's skin, and capable of absorbing and retaining liquids such as urine and other certain body exudates. The absorbent core 28 may comprise a wide variety of liquid-absorbent materials commonly used in disposable diapers and other absorbent articles such as comminuted wood pulp, which is generally referred to as air felt. Examples of other suitable absorbent materials include creped cellulose wadding; melt blown polymers, including co-form; chemically stiffened, modified or cross-linked cellulosic fibers; tissue, including tissue wraps and tissue laminates; absorbent foams; absorbent sponges; superabsorbent polymers; absorbent gelling materials; or any other known absorbent material or combinations of materials. The absorbent core 28 may comprise a liquid storage region 60, and other liquid handling elements 50, such as acquisition layers 52 and / or distribution layers 54. The absorbent core 28 may further comprise minor amounts (typically less than 10 %) of non-liquid absorbent materials, such as adhesives, waxes, oils and the like.

25 Exemplary absorbent structures for use as the absorbent assemblies are described in U.S. Patent 4,610,678 (Weisman et al.); U.S. Patent 4,834,735 (Alemany et al.); U.S. Patent 4,888,231 (Angstadt); U.S. Patent No. 5,260,345 (DesMarais et al.); U.S. Patent No. 5,387,207 (Dyer et al.); U.S. Pat. No. 5,397,316 (LaVon et al.); and U.S. Patent No. 5,625,222 (DesMarais et al.).

The backsheet 26 may be joined with the topsheet 24. The backsheet 26 prevents the exudates absorbed by the absorbent core 28 and contained within the article 20 from soiling other external articles that may contact the diaper 20, such as bed sheets and undergarments. In preferred embodiments, the backsheet 26 is substantially impervious to liquids (e.g., urine) and comprises a laminate of a nonwoven and a thin plastic film such as a thermoplastic film having a thickness of about 0.012 mm (0.5 mil) to about 0.051 mm (2.0 mils). Suitable backsheet films include those manufactured by Tredegar Industries Inc. of Terre Haute, IN and sold under the trade names

X15306, X10962, and X10964. Other suitable backsheet materials may include breathable materials that permit vapors to escape from the diaper 20 while still preventing exudates from passing through the backsheet 26. Exemplary breathable materials may include materials such as woven webs, nonwoven webs, composite materials such as film-coated nonwoven webs, and microporous films such as manufactured by Mitsui Toatsu Co., of Japan under the designation ESPOIR NO and by EXXON Chemical Co., of Bay City, TX, under the designation EXXAIRE. Suitable breathable composite materials comprising polymer blends are available from Clopay Corporation, Cincinnati, OH under the name HYTREL blend P18-3097. Such breathable composite materials are described in greater detail in PCT Application No. WO 95/16746, published on June 22, 1995 in the name of E. I. DuPont. Other breathable backsheets including nonwoven webs and apertured formed films are described in U.S. Patent No. 5,571,096 issued to Dobrin et al. on November 5, 1996.

The diaper 20 may also include such other features as are known in the art including front and rear ear panels, waist cap features, elastics and the like to provide better fit, containment and aesthetic characteristics. Such additional features are well known in the art and are e.g. described in U.S. Pat. No. 3,860,003 and U.S. Patent No. 5,151,092.

In order to keep the diaper 20 in place about the wearer, preferably at least a portion of the first waist region 36 is attached by the fastening member 42 to at least a portion of the second waist region 38, preferably to form leg opening(s) and an article waist. When fastened, the fastening system carries a tensile load around the article waist. The fastening system is designed to allow an article user to hold one element of the fastening system such as the fastening member 42, and connect the first waist region 36 to the second waist region 38 in at least two places. This is achieved through manipulation of bond strengths between the fastening device elements. Diaper 20 according to the present invention may be provided with a re-closable fastening system or may alternatively be provided in the form of pant-type diapers.

The embodiments of absorbent structures according to the present invention comprise a laminate structure, generally also referred to as a "sandwich" structure.

This refers to a design with two essentially flat outer layers, which are web materials or cut pieces of such web materials, as may be core web materials such as tissues, woven or nonwoven materials made from hydrophilized polymeric materials and the like.

One preferred material is a so called SMS material, comprising a spunbonded, a melt-blown and a further spunbonded layer. Highly preferred are permanently hydrophilic non-wovens, and in particular nonwovens with durably hydrophilic coatings. An alternative preferred material comprises a SMMS-structure.

The top layer 56 and the bottom layer 58 may be provided from two or more separate sheets of

materials or they may be alternatively provided from a unitary sheet of material. Such a unitary sheet of material may be wrapped around the storage layer 60 e.g. in a C-fold.

Preferred non-woven materials are provided from synthetic fibers, such as PE, PET and most preferably PP. As the polymers used for nonwoven production are inherently hydrophobic, they are preferably coated with hydrophilic coatings. A preferred way to produce nonwovens with durably hydrophilic coatings is via applying a hydrophilic monomer and a radical polymerization initiator onto the nonwoven, and conducting a polymerization activated via UV light resulting in monomer chemically bound to the surface of the nonwoven as described in co-pending European patent application EP-A-1403419.

5 The storage layer 60 is positioned between the two layers of web material and comprises a particulate material, in particular the above mentioned superabsorbent materials. Typically, these are in irregularly shaped or spherical granules, which can swell upon contact with liquids, such as urine. Whilst this material may be in various shapes or forms, such as granular, spherical, flakes, fibrous, it will often consist of irregularly shaped particles, having a mean particle size of from 10 μm to 1000 μm , preferably with less than 5% by weight having a particle size of 5 μm , and preferably with less than 5% by weight having a particle size of more than 1200 μm .

10 It has been found beneficial to use a particulate absorbent polymer material for absorbent cores made in the present invention. Without wishing to be bound by theory it is believed that such material, even in the swollen state, i.e. when liquid has been absorbed, does not substantially obstruct the liquid flow throughout the material, especially when the permeability as expressed by the saline flow conductivity of the absorbent polymer material is greater than 10, 20, 30 or 40 SFC- units, where 1 SFC unit is $1 \times 10^{-7} (\text{cm}^3 \times \text{s}) / \text{g}$. Saline flow conductivity is a parameter well recognized in the art and is to be measured in accordance with the test disclosed in EP 752 892 B (Goldman et al; P&G).

20 When employing such sandwich structures, there are a number of partly contradicting requirements, which these structures have to satisfy for an acceptable performance.

Thus, the particulate material is preferably immobilized. This refers to maintaining the arrangement of these particles in the structure during production as well as during use. In modern articles, the absorbency requirements in different parts of the article can be very different, such that for example more absorbency and hence absorbent material may be required in the proximity of the loading point than further away. Once the product design criteria have defined the absorbency distribution profile, this should be produced and maintained throughout the use cycle of the article, and in particular during use.

30 Further, the particulate material should be enabled to swell unrestrictedly. Even modern absorbent material such as described hereinabove exhibit absorbency properties depending to a certain

35

extent on the pressure exerted on them. This pressure may be a regular use-pressure, such as when the baby as a user sits on the article. However, such a pressure may be created in sandwich structures, when, for example, the outer web material layers 56 and 58 are tightly bonded to each other in a way which does not allow expansion, thusly reducing the absorbency properties of the structure.

5 A further important requirement relates to the distribution of liquid throughout the structure, both longitudinally (length wise or x-directionally) and laterally (cross- or y-directionally), but also along the thickness or caliper (or z-direction) of the structure.

As discussed in the background section, it is known to arrange particles in an absorbent laminate or sandwich structure, with particulate absorbent material arranged in particular pattern designs. The present invention is aiming at producing a particular pattern under favorable production conditions.

10 It has been found, that in particular for sandwich structures intended for liquid handling purposes, such for the use in absorbent structures, advantages for liquid handling properties can be realized, when the structure is designed such that a cluster of particulate material is not fully separated from a neighboring cluster by a bonding line or region. An exemplary structure is exhibited in Fig. 3, showing a sandwich structure 300 comprising a particulate material 310 sandwiched between a carrier material 320 and a cover material 330. Further, the particle clusters 350 are depicted as well as bonding point regions 360 and channel regions 370 between neighboring clusters.

15 It further has now been found, that it is of particular benefit that between adjacent clusters there is a bonding zone, which is essentially free of any particles, thusly allowing a good bond between the carrier layers, such as through gluing, or other means.

Nonetheless, the structure should enable good immobilization of the absorbent particles, in particular when these are wetted. In particular, the absorbent structures or the absorbent article comprising such structures should provide more than 50% preferably more than 60%, even more preferably more than 80% and most preferably more than 90% when tested in the Wet Immobilization Test, such as described in EP1447066 (Busam et al.; P&G).

20 A pattern of particulate material is considered to comprise a plurality of particle clusters 350, each comprising a plurality of particles 310.

Such a particle cluster (refer to Fig. 3 A and B) may comprise as few as about 10 particles, but may also be up to several hundred or even several thousands of particles. The particles may be arranged essentially in a "monolayer" sandwich structure, or multi-layer structures of essentially constant thickness, or may have varying thickness. This thickness may be expressed in terms of number of overlaying particle layers, or may be expressed by a local or an averaged basis weight,

35

referring to the weight of particles for a given unit area. The skilled person will readily realize, that even a "local" basis weight will need a certain amount of averaging. However, when the basis weight in a given region is by design not constant over this region, such as may be with an increase towards the centre of the region in case of a heap or pile of granular material, the basis weight distribution may be approximated by a smoothed curve when following a cross-sectional view through this heap. Alternatively, the basis weight of a region may be designed to be constant throughout the region, such that an average basis weight for this region can be determined, optionally together with certain variability thereof. The basis weight of the neighboring regions can be the same, but is not required to be so. Typical basis weights as averaged over a particle cluster range from 10 g/m² or even less to 500 g/m² or even 1000 g/m². Typical basis weights averaged over a pattern (i.e. including both particle cluster and the regions between these clusters, which can be essentially free of particles) range from 1 g/m² to more than 400 g/m² or even more than 800 g/m².

A cluster may have various forms and shapes, such as oval or elliptic or may be irregularly shaped. In a preferred embodiment these clusters are essentially circular. A cluster may have a diameter of more than 2 mm, preferably more than 4 mm, but less than 20 mm, preferably less than 8 mm. The distance between two neighboring clusters in a pattern may be more than 2 mm, preferably more than 5 mm, but less than 30 mm, preferably less than 15 mm, and even more preferably less than 7 mm.

A plurality of clusters is forming a primary pattern wherein the clusters are spaced apart in any geometric way. Such a pattern may comprise as few as two clusters, but will typically comprise more than ten clusters. Often, it will comprise less than 1000 clusters. Any plurality of cluster may form regular or irregular sub-patterns of the primary pattern. The clusters may be discrete or disconnected regions, such that each of these regions is essentially circumscribed by a region which is essentially free of particles. These particle free regions do not need to be identical to the bonding regions.

Typically, the particles are arranged to be in direct contact to each other, i.e. each particle will be in contact with at least one other particle. It may, however, also be the case, that they do not contact each other. Then however, the distance between neighboring particles within a cluster will generally be less than the distance of neighboring particle clusters within the primary or sub-pattern.

Whilst the patterns are formed in an essentially continuous arrangement, there will be a certain repetition of the pattern, which will allow the same pattern to repeat in subsequent articles. Thus, the term "macro-pattern" refers to such a repeating pattern each of which may form an element of such an article.

Any of these discrete regions may be arranged in a macro pattern, such as being formed by at least two discrete regions forming a repeating pattern with varying, and generally larger continuous regions there between.

A pattern may be described by a characteristic axis, such as indicated by axis 383 in Fig. 3.

5 Preferably, this axis is angularly offset to the longitudinal axis 100 of the diaper 20 or of the absorbent core respectively.

The bonding regions 360 between the clusters are preferably distinct regions rather than continuous regions, which would prevent channel regions 370 to be formed between the clusters. The bonding points may have varying shape and dimensions. In a preferred embodiment, the
10 bonding regions 360 have a circular form of a diameter 363 of not less than about 1 mm, preferably not less than 2 mm, or even not less than about 5 mm. Further, the bonding point region diameter is preferably less than about 20 mm, preferably less than about 10 mm. The distance 365 of adjacent bonding points is primarily defined by the cluster pattern and may be not less than about 5 mm, preferably not less than about 10 mm, but less than about 20 mm, preferably less
15 than about 15 mm.

A pattern can be unitary or can consist of sub-patterns; each of these sub-patterns may have different dimension or distances, respectively. The transition between sub-patterns may also be a gradual one. A pattern should be repeatable for subsequent absorbent structures for, e.g., a diaper. In addition to the bonding regions 360, there may be a peripheral bonding 387, so as to seal the
20 sandwich structure at the longitudinal or end edges.

Process for producing patterned sandwich structures

In a particular aspect, the present invention relates to a method of producing a sandwich structure having a pattern of particulate material enveloped between a carrier material.

25 Such a process should allow a very precise and repeatable production of the pattern at high or very high production speeds, i.e. preferably not being the overall speed production limiting process step in the overall production process, which may be up to 0.5 m/sec but often are 10 m/sec or even higher. Even further, the process should enable robust and inexpensive equipment designs.

30 Thus, the present invention relates to an essentially continuously operated lay-down of particulate material onto a surface, which is moveable at a preset surface speed, in a predetermined pattern. The pattern consists generally of regions comprising particulate material, and regions being essentially free of particulate material.

A schematic representation of the process can be seen in Fig. 4, showing a particulate material
35 supply 410, supplies 420 and 430 for carrier material 320 and cover material 330 respectively, a

carrier support means 470, and the optional element of a particle transfer devices 440. Also shown is the resulting sandwich structure 300 with the particulate material 310 between carrier material 320 and cover material 330.

5 The particulate material is generally supplied to the process from a particle storage system, and generally will be supplied in bulk form. Bulk refers to the fact, that the multitude of particles may be described by properties and parameters relating to an individual particle, such as composition, size, shape, particle density, and so on, but also by properties and parameters relating to a multitude of such particles, such as bulk density, particle size distribution, or flow properties.

10 The particulate material is deposited on a moving surface of a web material. Thusly, the process may exemplarily be described to position particles from a bulk storage system in a regular pattern onto a web material.

Such processes require not only an accurate positioning of the particulate material, but should be compatible with high of even very high "converting" speeds, which correspond within the current context generally to the speed of the moving surface.

15 Many current particle deposition systems as described in the background section hereinabove are generally very speed dependent, and either create unacceptable losses or variability with regard to positioning and applied weights when being run at such speeds.

20 Co-pending EP-Patent application (attorney docket reference CM2877FQ), which is incorporated herein by reference provides a solution for the aforementioned difficulties by providing a method for indirectly applying absorbent gelling material granules onto a carrier layer for use in an absorbent article, particularly a diaper, wherein particulate granules are taken up by a transfer device from a bulk storage. Referring to Fig. 4, the transfer device 440 has recesses 452 on the surface, wherein the number, size and position thereof determine the amount and pattern of superabsorbent particles 310 taken up by the transfer device 440. The transfer device 440 is
25 moveable from a loading position 442 adjacent to the bulk storage 410 to a discharging position 448 at which the carrier layer 320 is adjacent to the transfer device. The transfer device further has a means 444 for retaining the superabsorbent particles inside its recesses during movement of the transfer device 440 to the discharging position 448, and a means 446 for expelling the particles onto the carrier layer at the discharging meeting position 448. Preferably, these means
30 are vacuum and blow off air, respectively.

The present invention provides a method for creating a pattern of a particulate material sandwiched between a carrier material by depositing a pre-metered amount of the particulate material 310 on a carrier web 320, which forms a particular pattern of indentations 328, i.e. which is deformed out of the flat plane. This is achieved by placing the carrier material 320 on a carrier support structure 470 forming a particular pattern. Between the structure elements 475 forming
35

this pattern there is essentially free space allowing the carrier web to bulge into this space upon drawing forces, such as may be accomplished by a vacuum suction 472 generating a gas (air) flow through the fluid or air permeable carrier material 320. The particulate material 310 is then positioned in these indentations, thusly forming a cluster 350, and may fill these indentations
5 partly, completely or may over-fill these, such as by forming a "heap". In any of these cases, at least a part of the carrier material is essentially free of particulate material. This area is referred to as the bonding region 360, which may correspond to the carrier support area 322, or which may be larger or smaller than this.

The formation of the sandwich structure is completed by covering the patterned particulate
10 material of the indentations 350 with a cover material 330 and fixing the two web materials to each other, such as by applying adhesive material 495 at least to the bonding region of the carrier material or to the corresponding area of the cover material.

According to the present invention, the carrier material 320 is positioned onto a carrier support means 470. The carrier support means 470 comprises a surface, which may be brought into
15 contact with the carrier material at a matched speed. Such a match is achieved, if the surface moves with a speed which corresponds to the overall process speed.

The carrier support means may be of cylindrical shape rotatably positioned around its longitudinal axis. The outer cylindrical surface such as the shell 450 of a rotating drum will then form the support region for the carrier material. The carrier support means may also comprise an
20 essentially endless moveable belt carried upon a system of transporting rollers.

The carrier material 320 will be positioned on the "outer" surface of the carrier support means, outwardly referring to the outer surface of a drum, or to the surface opposite to that surface of a moving belt, which is in contact with the majority of the belt support rollers.

The carrier web will be positioned onto the carrier support area 477. This sub-region of the carrier
25 support means is the area, which is in contact with the carrier web, when this is positioned in an essentially untensioned state onto the carrier. Thus, if the carrier support means were a continuous (unapertured) drum, the carrier support area would be the cylindrical surface. If the carrier support means were an apertured drum, the carrier support area would be the area of the cylindrical surface minus the area of the apertures. If the carrier support means were a square grid formed
30 into a cylindrical shape, the carrier support area were the outwardly facing areas of the ribs of the grid.

In a preferred embodiment, the carrier support area is not a continuous region, i.e. the carrier support area can be represented by "islands", such as may be created by pins 475 protruding of the cylinder shell 450 (Fig. 5). The outermost surface covering the outward end points of the pins
35 475 corresponds to the carrier support area 477. The support pins may have a rectangular cross-

section. In a preferred embodiment, the support pins have a cylindrical shape, having a diameter
376 of preferably more than 1.5 mm, more preferably of more than 5 mm, but not more than 15
mm, more preferably of not more than 10 mm. If the outermost surface of the pins is not a flat
surface (see fig. 6 A, B) , but for example has a rounded, oval or circular cross-sectional shape
5 (see Fig. 6C, D), the area referred to is the projection to the area as would be covered by the
carrier web support material in an essentially untensioned state. The carrier support area may also
be formed by ridges, which may be straight or curved, or in the form of a cross (see Fig. 6E, F).
The carrier support area may be formed by "hybrid" structures, such as pins protruding out of a
grid or a cross, or a grid having varying heights, such that, for example the intersections points of
10 the grip form the most outward oriented areas (see Fig. 6 G, H).

Thus, the carrier web means is intended to be supported by the (most outwardly) oriented carrier
support area, but it may bulge or deform radially inwardly in the area other than the carrier
support area by mechanisms as described herein below.

However, for certain designs, it may be appropriate to support the carrier material not only at the
15 outer enveloping surface, but to also support the carrier material in a secondary support area. Such
an area can be compared with "low level islands", which do not have contact with the carrier
material if applied without deforming forces, but which will contact this only upon a certain
deformation (inward bulging) of the web, and then support it. For example, there can be one set
on carrier support pins having a certain height so as to form the primary carrier support area, and
20 a second set of pins having a lower height so as to form the secondary support area (see also Fig.
6 G, H).

The carrier support area will form a particular, predefined pattern. This pattern corresponds to the
desired particulate material pattern in the sandwich structure. Preferably, it has a macro pattern
generally along the x-direction of the web running over the carrier web support means, but
25 arranged at a predefined angle (see Fig. 5C). This may be repeating, and will typically reflect the
pattern of the patterned absorbent sandwich structure.

The dimensions of the carrier support area should further be adapted to the overall properties of
the carrier material. For example, when using support pins, the support area of an individual pin
should not be below a critical area, under which the local stress in the web might cause
30 destructive deformation, or penetration of the pin through the pores of the web.

These pins may be positioned at distances to the next neighboring pin of 5 mm or the distance
may be 20 mm or more. These pins may have a cylindrical shape. In order to avoid damaging of
the supported web material, each individual pin should have an essentially outwardly facing
surface of at least 3.5 mm², preferably 10 mm², but not more than 40 mm². The pins may also
35 have a non-cylindrical shape at the outwardly facing tip, which is in contact with the web. The

contacting area will then be considered to be the projection of the part of the tip being in contact with the carrier material upon deformation to a plane as formed by the carrier material in an untensioned state. Alternatively or in addition, the carrier support pattern may also be in the form of another geometrical pattern, such as by elongated pins, or ribs or ridges, which may be straight
5 or curved. Preferably, these do not form a continuous pattern; however two or more ribs may be connected, for example forming a cross-shaped support area. The carrier material has to satisfy the requirements for the final resulting structure, such as liquid handling properties in the case of fluid handling applications.

Further, the carrier material has to have the ability to deform under forces as applied during the
10 process. Whilst these forces can be of various types, the most preferred one is the drag force resulting from applying a fluid flow through a fluid permeable carrier material. In a particularly preferred embodiment, the carrier material is air permeable, such as by being an apertured film material or even more preferable a fibrous web.

The air permeability is connected to the material pore size and thickness, and hence – in the case
15 of fibrous materials – to the intrinsic density of the fiber material and the diameter of the fibers, respectively the diameter distribution in case of fibers having varying diameter. Further the carrier material has to have the ability to retain particles as deposited thereon.

This may be related to the permeability of the carrier material, as the above mentioned pore size may allow small particles to pass through. Whilst this is not desired in principle, a certain amount
20 of “fines” can be accepted to pass through. This may be then be recovered downstream.

Important for the present invention are the deformation properties of the carrier material. Deformation refers to the ability to elastically (i.e. essentially recoverably) or plastically deform upon application of forces as exerted by the carrier web deformation and fixation means.

As the most carrier materials for the present invention will be essentially two-dimensional webs
25 having an machine, longitudinal, or x-directional extension and a cross-machine, transversal, or y-directional extension perpendicular to the first.

Upon application of a force in any directions, the material will elongate along this direction. Thereby, the material will tend to compensate for this elongation by reducing its flat dimension perpendicularly to the direction of the direction of the force, as well as its thickness along the z-
30 direction. Typically, web materials are described by their properties measured along the machine direction (MD) as well as in cross-direction (CD), such as by creating stress-strain profiles and/or defining certain characteristic points of these profiles. Typically, such properties are determined by clamping a stripe of the material and applying pull forces to the clamp. The carrier material can further be characterized by its mechanical properties, namely its CD- and MD- extensibility at
35 certain loads, such as may be determined by conventional stress-strain measurements using line

clamps at a crosshead speed of 0.127 m/min. Preferably, the ratio of CD to MD elongation is more than 1 to 0.2, but preferably not more than 1 to 2.

5 As will be described herein below, useful carrier materials will be submitted to a force as may be generated by a fluid flow through the materials, such that a force in z-direction will be applied. However, as the carrier material is supported in the carrier support area, such as by carrier support pins, the deformation in this case will be determined by the CD- and MD- deformation properties. Henceforth, these properties have to be adjusted to the support area pattern.

10 The carrier material will be temporarily affixed to the carrier support means and will be deformed out of its flat / plane arrangement by the material holding means. Whilst a multitude of physical principles may be used, such as magnetic forces in case of magnetically responding materials, a particularly preferred embodiment relies on the use of fluid flow through the web.

15 To this end, the carrier support means may comprise a vacuum suction means 472, arranged such that gas – in particular air – is drawn through the web material. Based on the flow resistance due to the porosity of the web, the flow will induce a force in the z-direction, and thus deform the unsupported parts of the web.

20 Consequently, the web will form an indentation 328 (see Fig. 4B), the upper points will be defined by the support area (e.g. the support pins), and the “bottom of the valley” will be defined by the ratio of vacuum suction force, permeability and stress-strain properties of the carrier material. Thus, if an essentially homogeneous material would have the same properties in MD- and CD- direction, and – for example – the web support structure would consist of support pins arranged in a quadratic arrangement, the indentation would form a trough with its deepest points in the centre of the square.

25 Defining a space curve to connect two points of the squarely arranged support pins to follow the deformation of the web material will generally result in longer curve lengths than the linear distance of these support pins, and if the curve connects two diagonally opposed points, the space curve will have the longest length, generally following a shape which can be approximated by a hyperbolic curve.

30 Similarly defining an outer surface by connecting the support area – i.e. in the present case the square connecting the four corner points of the support pins, and thus the area of the web covers before applying the suction forces – this can be compared to the actual surface area of the deformed material forming the indentation.

35 Similarly, a volume can be defined for the indentation formed by the deformed carrier material, which is circumscribed by the deformed web material and the surface as covered by the web material prior to deformation through the deformation means. Preferably, this volume is at least

30 mm³, preferably at least 100 mm³, but less than 1000 mm³.

This "indentation volume" can be compared to the volume of the particles, which are to be positioned therein. Depending on the design target, the volume of the particles of a cluster may fill more than 5 % of the volume of the indentation, or more than 50 % of the volume. In the case
5 of "overfilling" (or forming a heap), the indentations will typically not be filled by more than 150 % of their volume.

After the carrier material 320 has been deformed to form the indentations 328 and the particulate material 310 has been positioned in or on these indentations, the structure is covered by a cover material, typically a web material, too. This cover material is primarily defined by the
10 requirements of the final application. It may be the same material as the carrier material, and may be unitary with the carrier material, such as when then particulate material is deposited in a region – such as the centre stripe region – of a web material and laterally outwardly oriented part or parts of the material are then folded over such as along a longitudinal fold line, so as to cover the particulate material.

15 It may also be the same kind on material, but being supplied separately, or it may also be a different material, which is suitable for the intended application as well as for being bonded to the carrier material.

The carrier material and the cover material are connected to each other, such as permanently bonded so as to form the composite sandwich structure with the particle pattern between. This
20 bonding can be achieved by conventional means, such as adhesives, or thermo bonding or the like.

It has been found important, that the bonding is not impeded by particles positioned between the webs in the bonding regions. Bonding regions refers to regions, which are essential for ensuring good permanent bonding. Thus, in the above described example of support pins forming the
25 support area, the bonding region will generally coincide with this area, but may be somewhat smaller or larger than the support area.

For example, when spray applying adhesives, it might be preferable to have a bonding area of more than 2%, preferably of more than 7 %, but less than 50 % of the total pattern area. The bonding area may be larger than the support area, which will typically be the case when the
30 indentations are not completely filled with particulate material. If applying melt fusion bonding at the support pins, the bonding area might be as little as 50% of the support area.

Thus, the bonding region is preferably essentially free of particulate material. The term "essentially free" refers to the fact that any particles present in this area should not lead to break up of the bonding under normal use conditions.

35 However, if the particulate material exhibits a broad particle size distribution profile, or if particle

break up is created during the process, a certain amount of "dust" is acceptable in this regions. A method of assessing the amount of "bonding region particle loading" is described hereinafter for the application of absorbent materials.

After having described the elements required for executing the present invention, the following
5 will describe the individual process steps.

Overall, it is assumed, that a sandwich structure is to be produced comprising particulate material in a predefined pattern. The process is an essentially continuous process, starting from essentially endless web materials and combining these with particulate materials as provided in bulk supply form. The resulting continuous sandwich composite may be separated, such as by cutting, into
10 individual pieces, each comprising at least a macro pattern of the particulate material sandwich.

The individual process steps are now explained in more detail. The order does not necessarily reflect a chronological order for these steps.

a - An essentially flat web material is provided to serve as carrier material and / or as cover material forming the outer sandwich layers. Thus, the web material may be unitary forming
15 both outer sandwich layers such as by longitudinal folding. There may also be two different web materials, one forming the carrier material, and the other the cover material. In a preferred execution, the web materials are separate, but of the same type. The properties of the web materials have to be compatible with the intended use. In addition and in a preferred embodiment, the carrier material is permeable for gas, such as air, but not for particles. In a
20 preferred embodiment, the web materials are nonwoven materials, and more preferably a combination of a spunbonded layer (S) with a meltblown layer, so as to form a SMS or more preferably a SMMS type web.

b - An essentially endless support means for the carrier having a support pattern is provided, preferably a rotatable drum with the support pattern being on the outer cylinder or shell
25 surface of this drum. Preferably, the carrier support pattern is formed by carrier support pins. Such pins extend towards the outer surface of the carrier support means, which then can generally be described by enveloping the outwardly facing areas of these pins.

c - In order to first hold the carrier material and to then form indentations therein, a carrier material holding means is actuated. In the preferred embodiment of the carrier means being a
30 rotating drum respectively the rotating shell of a drum, and the carrier material is an air permeable material which is positioned on this shell, the carrier material holding means may be vacuum suction inside the drum. This may be achieved by non-rotating vacuum boxes underneath the surface of the drum. Thereby, air is sucked through the carrier material in this section, thereby exerting forces on the web, thusly holding it affixed on the surface of the
35 drum and deforming it in unsupported regions. The amount of suction, i.e. the degree of

- vacuum created depends on the permeability properties of the web, the unsupported area, and the desired deformation (i.e. the size of the indentations).
- 5 d - The carrier material is guided towards the outer surface of the carrier web support and deformation means at a match speed, e.g. the carrier material moves at a carrier speed of more than 0.5 m/sec, more preferably more than 5 m/sec, matching the radial outer surface speed of the carrier support drum.
- e - As a further process step, a particulate material is provided, such as conventional superabsorbent particles. Preferably this material is provided in bulk form, such as in a hopper.
- 10 f - This material is metered and dosed according to the requirements in the resulting product. This dosing may be constant over time or variable. In a preferred embodiment, the dosing already pre-forms a particle cluster in a particular pattern, as may be desirable for the resulting product.
- 15 g - The particulate material is then transferred to the outwardly facing surface of the carrier material, or the receiving surface of the carrier material, while this is supported by in the web support areas on the web support means, and deformed in to indentations in the unsupported regions.
- 20 h - Further, a sandwich fixation means is actuated for affixing the carrier material and the cover material while the particle pattern is maintained. In a preferred embodiment, the fixations means is application of spray glue before and/or after the particles are transferred onto the carrier material. In case of carrier and cover web having matching melt properties, the bonding means may also be heat fusion bonding, such as by ultra-sound. The carrier and cover webs are affixed to each other in the bonding area. The bonding area can be described by at least covering the web support area, but will typically extend longitudinally and laterally
- 25 outwardly of this region, thusly covering an area of more than 2%, preferably of more than 7 %, but less than 50 % of the support region. Preferably, the bonding area is preferably essentially free of particles. This requirement can be assessed by using the method for determining particles in the bonding area, as described in the method section herein below. Optionally, the bonding means may also be applied to the particles.
- 30 i - After the particles are positioned on the carrier material the cover material is applied and bonded to the carrier material, thereby closing the sandwich structure. This is a preferred but optional step. In accordance with the present invention a sandwich structure comprising a carrier material but no cover material can be provided, as the sandwich fixation means can provide sufficient integrity to the structure and make it a sandwich-like structure, such that it
- 35 is unnecessary to further provide a cover material.

During this process, it is important, that the carrier web is supported only in the support pattern region of the web support means, and that the carrier material is deformed by the carrier holding means such that indentations are formed in the unsupported regions. This forms a primary pattern, optionally comprising sub-patterns. The pre-metered particulate material is preferably deposited essentially exclusively in these indentations, preferably thereby filling at least 5 % of the indentation volume, preferably filling not more than 150 % of the indentation volume.

Method for determining absence of particles in bonding area

10 The test has the purpose of assessing the bonding areas with regard to contamination of particulate material, in particular of superabsorbent material.

A test solution is prepared by diluting 1.5 g of purple bromocresol indicator (CAS number 115-40-2) in 10 l of de-ionized water, and adding 4 ml of 1 mol/l hydrochloric acid (1 N HCl). The test specimen is wetted by the test solution, e.g. by using a pointed pipette and adding the solution drop wise, or by using a fine spray bottle. The amount of added test liquid will depend on the size of the sample and the amount of superabsorbent material. It should be sufficient to wet all particles in the considered region so as to ease visual counting, which is then performed on the respective regions. The assessment may also be supported by employing a magnifying glass or a microscope with suitable magnification. Very fine particles also referred to as dusts, and generally having a size corresponding to the pore size of the carrier and/or cover material, are not counted. A region is classified as being "free of superabsorbent particles", if less than two particles are detectable. A region is classified as being "essentially free of superabsorbent particles", if particles present in the bonding area do cover more than about 50 % of this area.

25 All documents cited in the Detailed Description of the Invention are, in relevant part, incorporated herein by reference; the citation of any document is not to be construed as an admission that it is prior art with respect to the present invention.

While particular embodiments of the present invention have been illustrated and described, it would be obvious to those skilled in the art that various other changes and modifications can be made without departing from the spirit and scope of the invention.

Each parameter for which a value is defined herein is a technical parameter, which in the context of the present invention is not to be understood literal. Hence, all embodiments having parameters functionally equivalent to the parameters stated herein are intended to be covered by the scope of the invention, e.g. a length of "10 mm" has to be understood as meaning "about 10 mm".

Claims

1. A method for producing a sandwich structure (300) comprising a pattern of particulate material (310), said method comprising the steps of
- 5 a - providing at least one essentially flat web material as carrier (320) and / or cover (330) material ;
- b - providing an essentially endless support means (470) for said carrier material (320) having a support pattern,
- c - providing a carrier material holding means (472),
- 10 d - positioning said carrier material (320) over said support means (470), whereby said carrier material (320) contacts said support pattern with its support surface
- and whereby the relative speed between carrier material and the contact surface of said carrier support means is essentially zero;
- e - providing a particulate material (310);
- 15 f - pre-metering the amount of the particulate material (310),
- g - providing a sandwich fixation means (495),
- h - preferably combining said cover material (330) with said carrier material (320) and said particulate material (310) being sandwiched there between;
- characterized in that
- 20 i- said carrier material (320) is supported only in the region of the support pattern of the support means;
- j- said carrier material (320) is deformed by said carrier holding means (472) such that indentations (328) are formed in the unsupported regions,
- k- and in that said particulate material (310) is transferred to said carrier material (320)
- 25 into said indentations (328);
- thereby forming a primary pattern of particulate material.
2. A method for producing a sandwich structure (300). according to claim 1, wherein said carrier material is a non-woven material, preferably of the SMS or SMMS type.
- 30
3. A method for producing a sandwich structure (300) according to claim 1 or 2, wherein said carrier material (320) has a CD-extensibility or a MD-extensibility of more the 20 %, preferably more than 100 %, but even more preferably not more than 200 %.

4. A method for producing a sandwich structure (300) according to claim 1, 2, or 3, wherein said carrier material has a ratio of MD-extensibility to CD-extensibility at a given load of not more than one to two.
- 5 5. A method for producing a sandwich structure (300) according to any of the preceding claims, wherein said cover material is a non-woven material, optionally being the same material as the carrier material.
- 10 6. A method for producing a sandwich structure (300) according to any of the preceding claims, wherein said particulate material (310) is a bulk material, preferably a superabsorbent, more preferably a partially cross-linked polyacrylate material.
- 15 7. A method for producing a sandwich structure (300) according to any of the preceding claims, wherein said carrier support means (470) is a rotatable drum, preferably having an outer cylinder shell (450).
8. A method for producing a sandwich structure (470) according to any of the preceding claims, wherein said carrier holdings means (472) is a vacuum air suction.
- 20 9. A method for producing a sandwich structure (300) according to any of the preceding claims, wherein said carrier support pattern comprises support pins (475).
- 25 10. A method for producing a sandwich structure (300) according to claim 9, wherein said carrier support pins (475) have a distance (355) of more than 5 mm and not more than 30 mm from each neighboring support pin.
- 30 11. A method for producing a sandwich structure (300) according claim 9 or 10, wherein said support pins (375) have outwardly extending surface of at least 0.8 mm², preferably of at least 4 mm², but not more than 170 mm², preferably not more than 80 mm².
12. A method for producing a sandwich structure (300) according to any of the preceding claims, wherein said sandwich fixation means (375) is thermo-bonding or glue-bonding, preferably a sprayed adhesive.

13. A method for producing a sandwich structure (300) according to any of the preceding claims, wherein said bonding region (360) is at least 2 %, preferably at least 7 %, but more preferably not more than 50 % of the area of the pattern area.
- 5 14. A method for producing a sandwich structure (360) according to any of the preceding claims, wherein said bonding region (360) comprises essentially no particulate material, as assessed by the method for determining the absence of particles in the bonding area.
- 10 15. A method for producing a sandwich structure (360) according to any of the preceding claims, wherein said carrier fixation means (472) extends said carrier material such that it deforms out of the original flat state forming an indentation (328).
- 15 16. A method for producing a sandwich (300) structure according to claim 15, wherein said indentations (328) have a volume of more than 30 mm³, preferably more than 100 mm³, but less than about 1000 mm³.
17. A method for producing a sandwich structure (300) according to claim 15 or 16, wherein the particulate material fills more than 5 % of the volume of said indentations (328), preferably not more than 150 % of the volume of said indentations (328).

Fig. 2

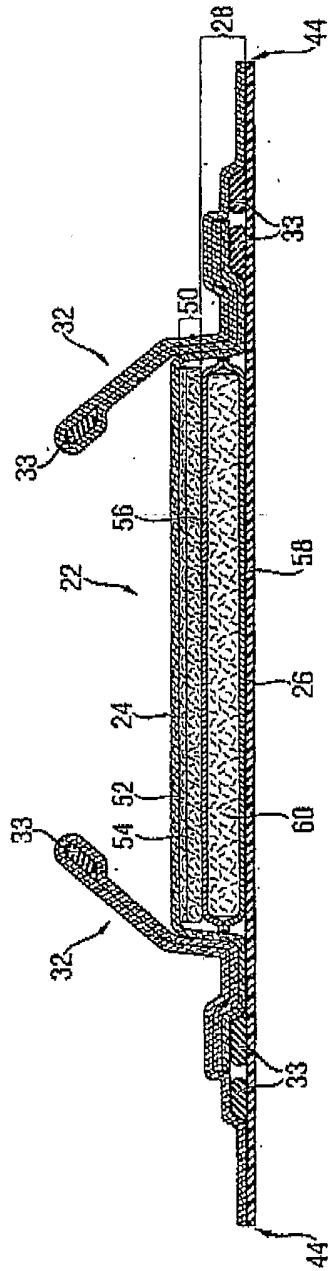

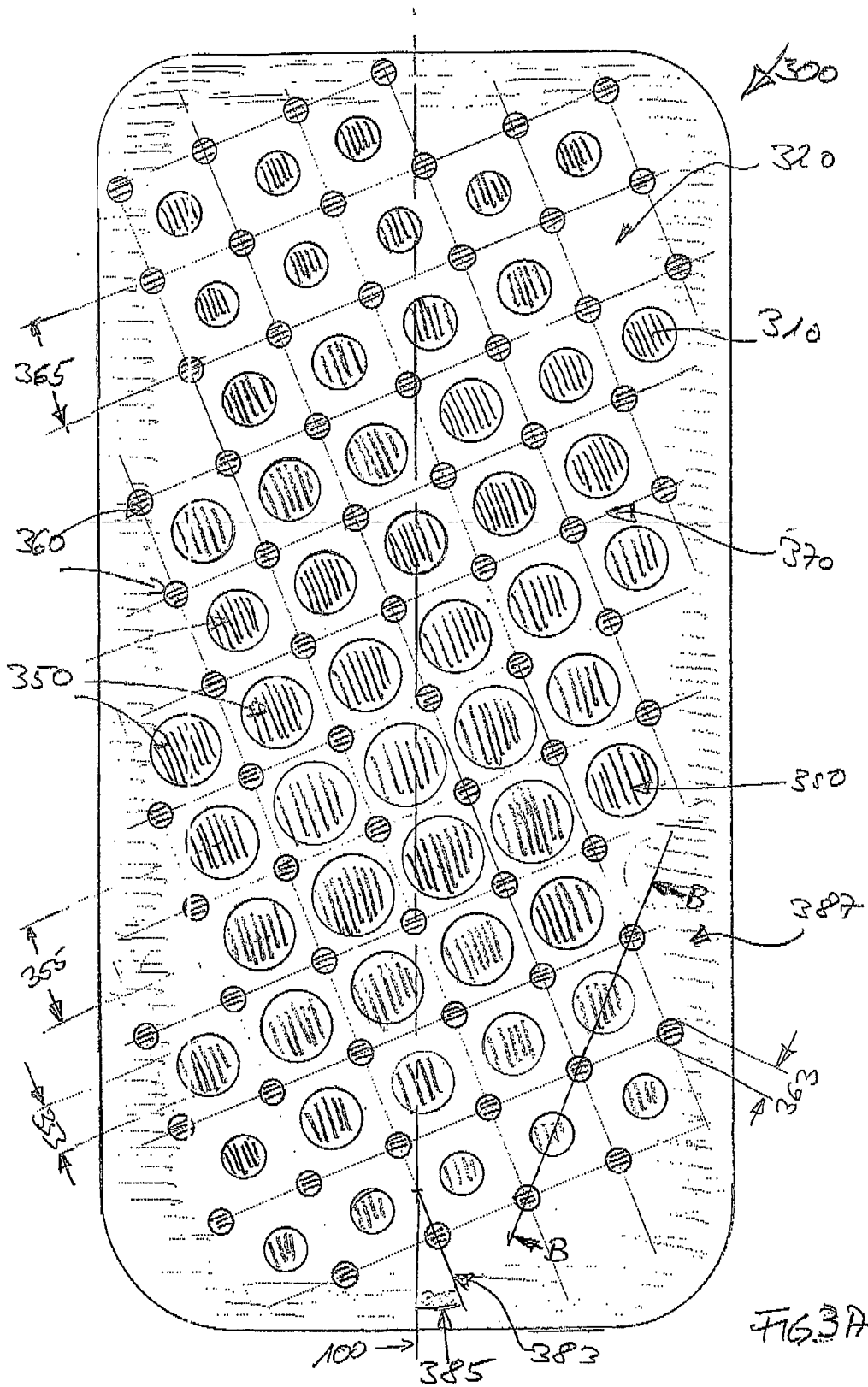

FIG 3A

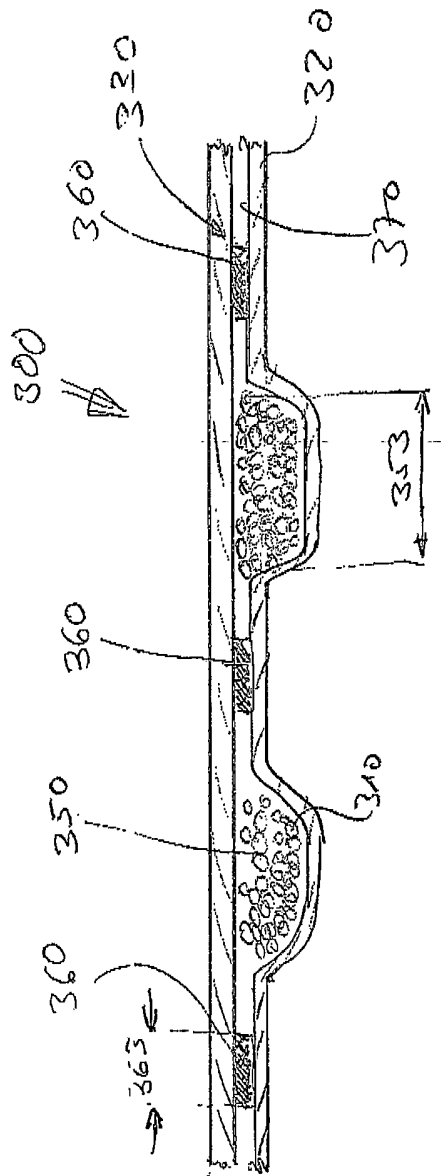

FIG. 3B

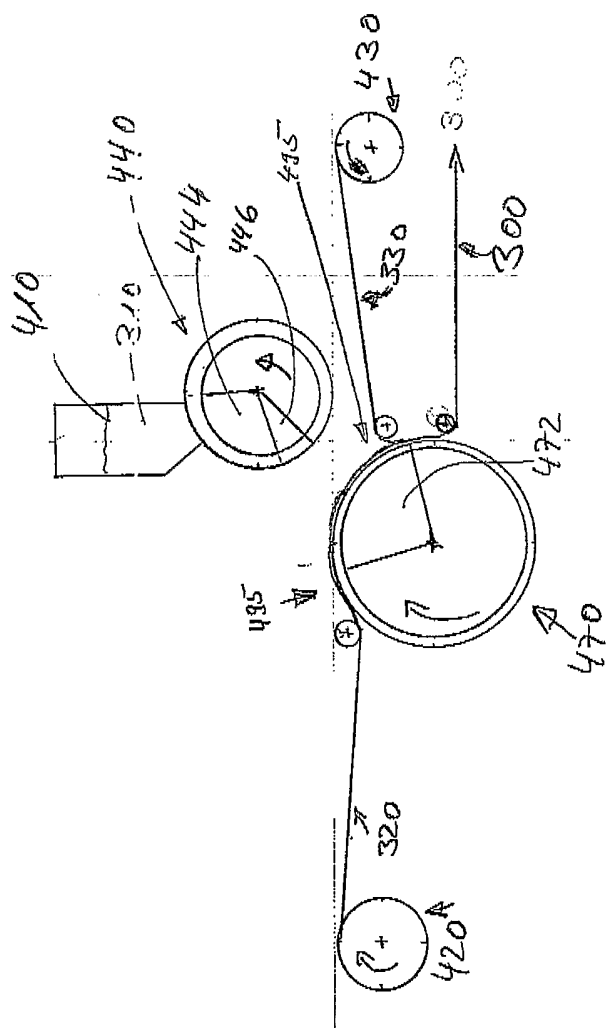
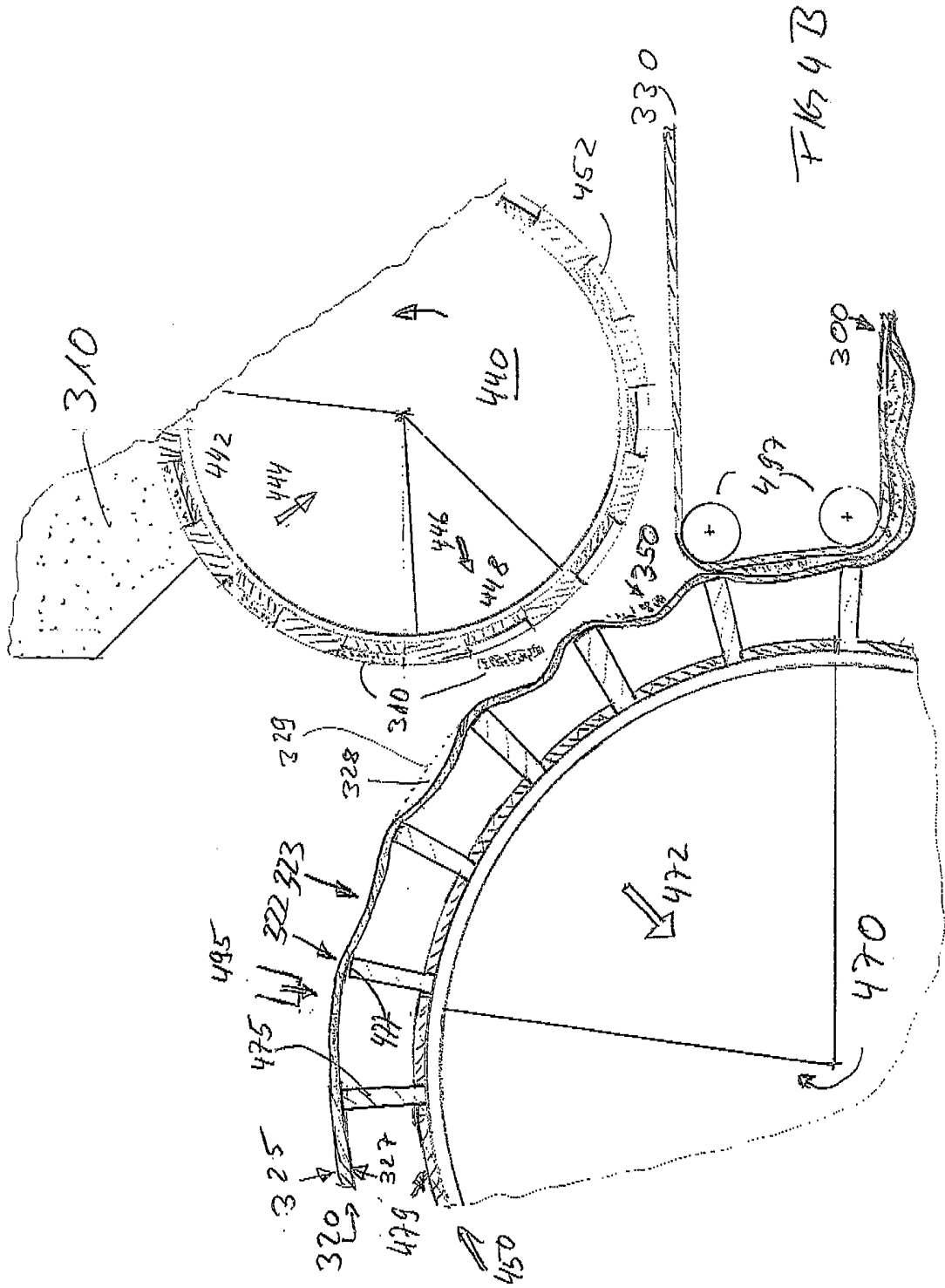

FIG. 4A



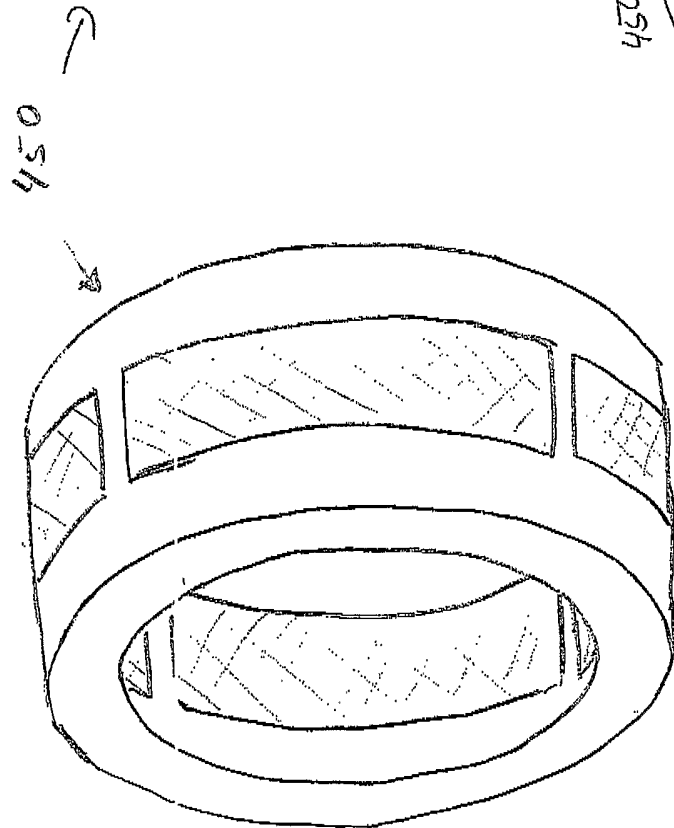
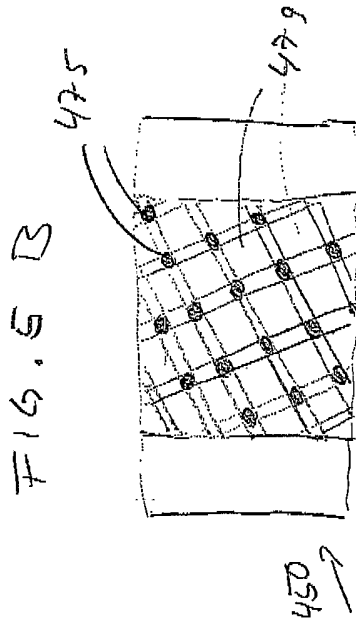
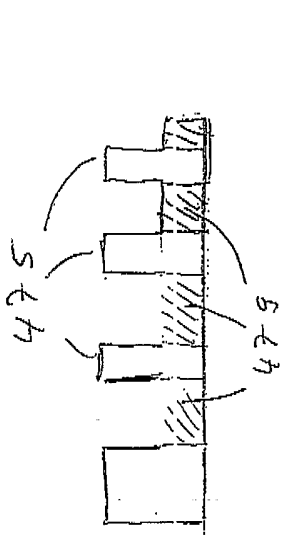

FIG. 5G

FIG. 5A

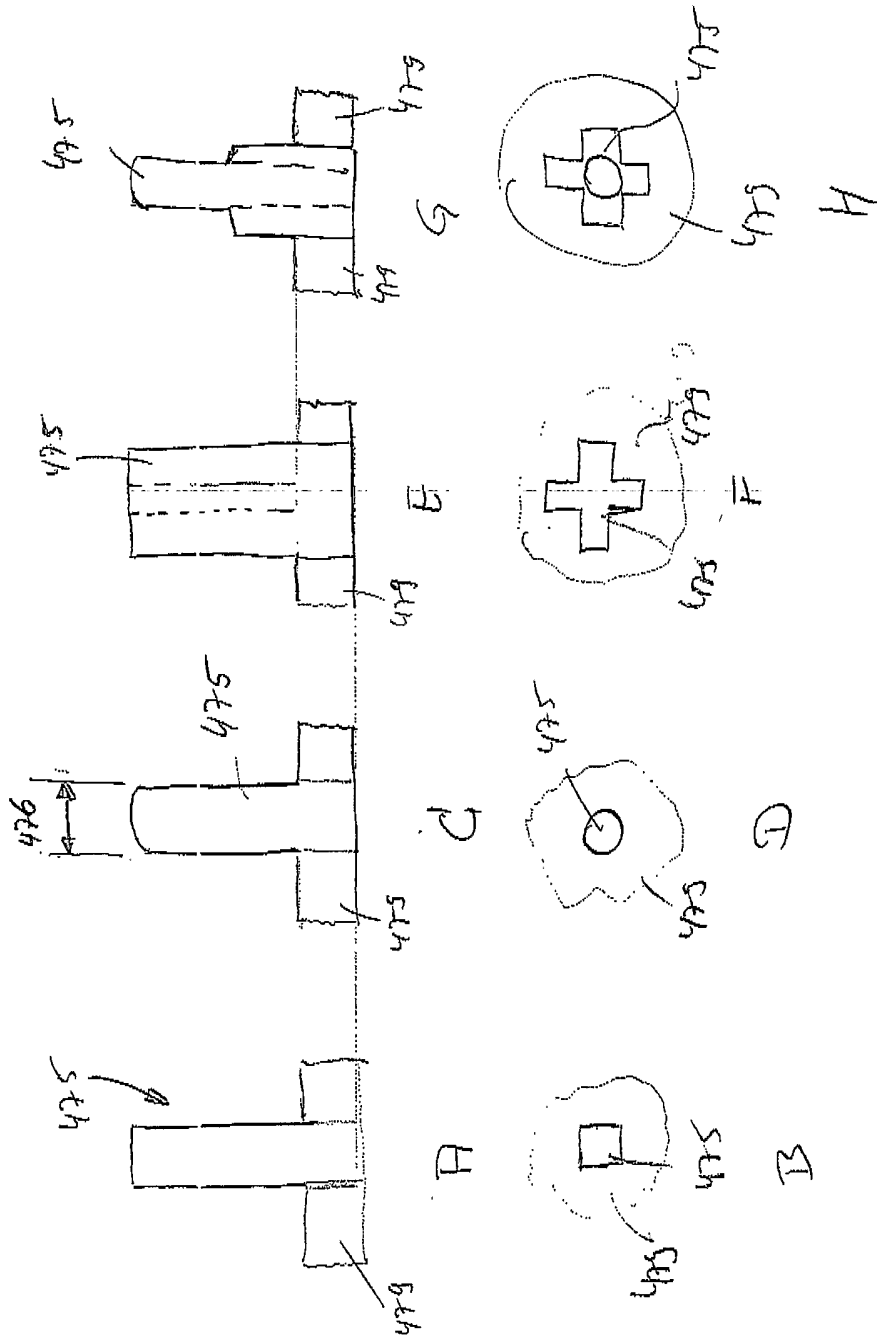

FIG. 6

INTERNATIONAL SEARCH REPORT

PCT/US2005/026831

A. CLASSIFICATION OF SUBJECT MATTER IPC 7 A61F13/15		
According to International Patent Classification (IPC) or to both national classification and IPC		
B. FIELDS SEARCHED Minimum documentation searched (classification system followed by classification symbols) IPC 7 A61F		
Documentation searched other than minimum documentation to the extent that such documents are included in the fields searched		
Electronic data base consulted during the international search (name of data base and, where practical, search terms used) EPO-Internal		
C. DOCUMENTS CONSIDERED TO BE RELEVANT		
Category °	Citation of document, with indication, where appropriate, of the relevant passages	Relevant to claim No.
X	WO 96/29967 A (THE PROCTER & GAMBLE COMPANY; HAUBACH, KLAUS, KARL, FERDINAND) 3 October 1996 (1996-10-03) page 3 - page 5, paragraph 1; figure 3	1-17
X	US 5 494 622 A (HEATH ET AL) 27 February 1996 (1996-02-27) column 6, line 21 - column 8, line 37; figures	1-17
A	US 4 994 053 A (LANG ET AL) 19 February 1991 (1991-02-19) the whole document	1-17
<input type="checkbox"/> Further documents are listed in the continuation of box C. <input checked="" type="checkbox"/> Patent family members are listed in annex.		
° Special categories of cited documents :		
A document defining the general state of the art which is not considered to be of particular relevance *E* earlier document but published on or after the international filing date *L* document which may throw doubts on priority claim(s) or which is cited to establish the publication date of another citation or other special reason (as specified) *O* document referring to an oral disclosure, use, exhibition or other means *P* document published prior to the international filing date but later than the priority date claimed	*T* later document published after the international filing date or priority date and not in conflict with the application but cited to understand the principle or theory underlying the invention *X* document of particular relevance; the claimed invention cannot be considered novel or cannot be considered to involve an inventive step when the document is taken alone *Y* document of particular relevance; the claimed invention cannot be considered to involve an inventive step when the document is combined with one or more other such documents, such combination being obvious to a person skilled in the art. *&* document member of the same patent family	
Date of the actual completion of the international search	Date of mailing of the international search report	
17 October 2005	25/10/2005	
Name and mailing address of the ISA European Patent Office, P.B. 5818 Patentlaan 2 NL - 2280 HV Rijswijk Tel. (+31-70) 340-2040, Tx. 31 651 epo nl, Fax: (+31-70) 340-3016	Authorized officer Boccignone, M	

INTERNATIONAL SEARCH REPORT

PCT/US2005/026831

Patent document cited in search report		Publication date		Patent family member(s)		Publication date
WO 9629967	A	03-10-1996	AT	294557 T		15-05-2005
			AU	711198 B2		07-10-1999
			AU	5180896 A		16-10-1996
			CA	2213672 A1		03-10-1996
			DE	29505307 U1		24-05-1995
			EP	0817603 A1		14-01-1998
			JP	11502741 T		09-03-1999
US 5494622	A	27-02-1996	CA	2138680 A1		13-01-1996
US 4994053	A	19-02-1991	NONE			