

(19) World Intellectual Property Organization
International Bureau



(43) International Publication Date
12 May 2011 (12.05.2011)

(10) International Publication Number
WO 2011/056582 A1

(51) International Patent Classification:
A61M 39/10 (2006.01)

(21) International Application Number:
PCT/US2010/054112

(22) International Filing Date:
26 October 2010 (26.10.2010)

(25) Filing Language: English

(26) Publication Language: English

(30) Priority Data:
61/255,453 27 October 2009 (27.10.2009) US
61/316,503 23 March 2010 (23.03.2010) US

(71) Applicant (for all designated States except US):
NXSTAGE MEDICAL INC. [US/US]; 439 South Union Street, Fifth Floor, Lawrence, MA 01843 (US).

(72) Inventors; and

(75) Inventors/Applicants (for US only): **SCHNELL, William, J.** [US/US]; 1100 Crane Boulevard, Libertyville, IL 60048 (US). **BRUGGER, James, M.** [US/US]; 4 Savory Street, Newburyport, MA 01950 (US).

(74) Agents: **CATAN, Mark, A.** et al.; Miles & Stockbridge P.C., 1751 Pinnacle Drive, Suite 500, McLean, VA 22102-3833 (US).

(81) Designated States (unless otherwise indicated, for every kind of national protection available): AE, AG, AL, AM, AO, AT, AU, AZ, BA, BB, BG, BH, BR, BW, BY, BZ, CA, CH, CL, CN, CO, CR, CU, CZ, DE, DK, DM, DO, DZ, EC, EE, EG, ES, FI, GB, GD, GE, GH, GM, GT, HN, HR, HU, ID, IL, IN, IS, JP, KE, KG, KM, KN, KP, KR, KZ, LA, LC, LK, LR, LS, LT, LU, LY, MA, MD, ME, MG, MK, MN, MW, MX, MY, MZ, NA, NG, NI, NO, NZ, OM, PE, PG, PH, PL, PT, RO, RS, RU, SC, SD, SE, SG, SK, SL, SM, ST, SV, SY, TH, TJ, TM, TN, TR, TT, TZ, UA, UG, US, UZ, VC, VN, ZA, ZM, ZW.

(84) Designated States (unless otherwise indicated, for every kind of regional protection available): ARIPO (BW, GH, GM, KE, LR, LS, MW, MZ, NA, SD, SL, SZ, TZ, UG, ZM, ZW), Eurasian (AM, AZ, BY, KG, KZ, MD, RU, TJ, TM), European (AL, AT, BE, BG, CH, CY, CZ, DE, DK, EE, ES, FI, FR, GB, GR, HR, HU, IE, IS, IT, LT, LU, LV, MC, MK, MT, NL, NO, PL, PT, RO, RS, SE, SI, SK, SM, TR), OAPI (BF, BJ, CF, CG, CI, CM, GA, GN, GQ, GW, ML, MR, NE, SN, TD, TG).

Published:

— with international search report (Art. 21(3))

(54) Title: FLUID LINE SAFETY DEVICE

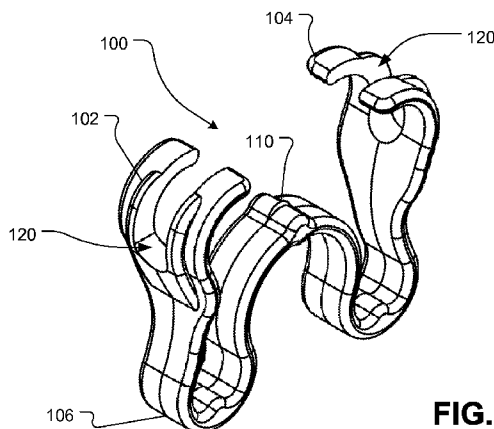

FIG. 3

(57) Abstract: A restraining device for a tubing connector assembly can include a resilient member having a generally U-shape with forked ends that curve toward each other. Each forked end can have a recess between tines thereof. Each recess can have a blind end. The resilient member can have a bend provided with an engagement bump. The engagement bump and forked ends can be aligned such that the engagement bump coincides with a line joining the blind ends. When a cylindrical connector assembly tube is placed in the recesses, the engagement bump is urged against a side of the connector assembly to thereby prevent inadvertent disconnection.



WO 2011/056582 A1

FLUID LINE SAFETY DEVICE**CROSS-REFERENCE TO RELATED APPLICATIONS**

The present application claims the benefit of U.S. Provisional Application No. 61/255,453, filed October 27, 2009, and U.S. Provisional Application No. 61/316,503, filed March 23, 2010, both of which are hereby incorporated by reference herein in their entireties.

FIELD

This present disclosure relates generally to fluid line connections, and, more particularly, to restraining and safety devices for fluid lines and tubing connections, such as those employed in medical treatment devices.

BACKGROUND

Tubing connections are commonly used in medical treatment systems, chemical processing plants, pharmaceutical plants, laboratories, manufacturing systems, hydraulic systems, etc. A common class of connectors mates by mutually rotating parts of the connectors and/or by pushing the connectors together. A common type of connector is a luer-type connector, which can include a relatively long male element that fits tightly into a channel of a female element.

Originally, luer-type connectors were merely pushed together in order to make a connection. Over time, the connectors evolved to include threaded collars so as to make it more difficult for the connections to arbitrarily disconnect. The threaded collars thus may increase the reliability of the luer-type connections. However, in some applications (e.g., extracorporeal blood treatment systems), it may be desirable

to mitigate even minute levels of risk that may be caused by disconnection of the luer-type connections. Accordingly, there is a need in the art for simple and inexpensive ways to increase the reliability of connectors for fluid-carrying vessels. In particular, such a need is felt in the area of tubing systems used in medical treatment devices. It may also be desirable to enhance the security of luer-type connectors without altering the familiar features of their design or usability.

SUMMARY

Various restraining mechanisms and methods for preventing the accidental decoupling of connectors are disclosed herein. A generally U-shaped resilient member can have ends with openings therein for receiving tubing attached to the connectors. The ends of the resilient member can be arranged so as to apply an urging force to opposite ends of the connectors to prevent separation of the connectors. Other portions of the resilient member, such as a centrally located bend with an engagement bump, can interact with a portion of the connectors to further prevent inadvertent connector separation. The various mechanisms and methods are particularly applicable to luer-type connectors. However, the mechanisms and methods can also be used with other types of connectors or connections according to one or more contemplated embodiments.

In embodiments, a restraining device can include a resilient member having a generally U-shape with forked ends that curve toward each other. Each forked end can have a recess between tines thereof. Each recess can have a blind end. The resilient member can have a bend provided with an engagement bump. The engagement bump and forked ends can be aligned such that the engagement bump coincides with a line joining the blind ends. When a cylindrical connector assembly

tube is placed in the recesses, the engagement bump is urged against a side of the connector assembly.

In embodiments, a restraining member for a connector assembly can include a forked first end having a first recess between tines thereof and a closed second end having an opening therein. The first recess can be sized and shaped so as to accept a first tubing connected to one end of the connector assembly. The second end can be sized and shaped so as to accept a second tubing connected to another end of the connector assembly. The restraining member can have a bend with an engagement bump arranged between the first and second ends. The bend can be arranged such that, when the first and second ends abut against respective first and second ends of the connector assembly, the engagement bump interacts with a knurled attachment member so as to inhibit rotation thereof.

In embodiments, a tubing set can include a restraining member, a tubing line, and a connector. The restraining member can include a forked first end having a first recess between tines thereof, a closed second end having an opening therein, and a bend with an engagement bump arranged between the first and second ends. The tubing line can pass through the opening in the closed second end of the restraining member. The connector can be attached to an end of the tubing line.

In embodiments, a restraining member for a connector assembly can include first and second ends with a bridge connecting the first and second ends. The first end can have a first U-shaped recess therein. The first recess can be sized and shaped so as to accept a first tubing connected to one end of the connector assembly. The second end can have an opening therein. The second end can be sized and shaped so as to accept a second tubing connected to an other end of the connector assembly. The bridge can have a bend therein with an engagement bump. The restraining

member can also have an attachment portion configured to secure the restraining member to the second tubing such that the restraining member cannot be used with another second tubing.

In embodiments, a connector assembly for first and second tubes can have mating connectors thereon. One of the mating connectors can have a locking collar that locks the other of the mating connectors. A restraining member for the connector assembly can include first and second ends and a flexible bridge portion. The first and second ends can be shaped to capture and position first and second mating connector parts attached to the first and second tubes, respectively. The flexible bridge portion can connect the first and second ends. The flexible bridge portion can be shaped such that when the first and second mating connector parts are connected, the first and second ends are urged together thereby urging the first and second mating connectors together. The flexible bridge portion can have an engagement element with an edge that captures and immobilizes the locking collar.

In embodiments, a restraining device can include a resilient member having a generally U-shape with forked ends that curve toward each other. Each forked end can have a recess between tines thereof. The forked ends can have facing bowl shapes. The resilient member can have a bend provided with an engagement bump. The engagement bump and the forked ends can be aligned such that the engagement bump coincides with a line joining the facing bowl shapes. When a cylindrical connector assembly tube is placed in the recesses, the engagement bump is urged against a side of the connector assembly.

In embodiments, a device is configured to urge mating connectors together while simultaneously urging an engagement member into at least one of the mating

connectors, such that, by the urging an engagement member, the at least one of the mating connectors is prevented from rotating.

Objects and advantages of embodiments of the present disclosure will become apparent from the following description when considered in conjunction with the accompanying drawings.

BRIEF DESCRIPTION OF DRAWINGS

Embodiments will hereinafter be described with reference to the accompanying drawings, wherein like reference numerals represent like elements. The accompanying drawings have not necessarily been drawn to scale. Any dimensions illustrated in the accompanying graphs and figures are for illustration purposes only and may not represent actual or preferred dimensions. Where applicable, some features may not be illustrated to assist in the description of underlying features.

FIG. 1 is a side view of a restraining clip according to embodiments of the disclosed subject matter.

FIG. 2 is a section view C-C of the restraining clip taken along a plane parallel to the view of FIG. 1.

FIG. 3 is an oblique projection of the restraining clip of FIG. 1.

FIG. 4 is a fragmentary section view A-A of the restraining clip of FIG. 1 taken along plane perpendicular to the view of FIG. 1.

FIG. 5 is an end elevation view of the restraining clip of FIG. 1.

FIG. 6 is a plan view of the restraining clip of FIG. 1.

FIG. 7 shows the restraining clip of FIG. 1 attached to interconnected tubing ends according to embodiments of the disclosed subject matter.

FIG. 8 is an image of an actual embodiment similar to that of FIG. 7.

FIG. 9 shows a scissor-type restraining clip according to embodiments of the disclosed subject matter.

FIGS. 10 and 12 are oblique projection views of another restraining clip with a leash portion according to embodiments of the disclosed subject matter.

FIG. 11 is an end elevation view of the restraining clip of FIG. 10.

FIG. 13 is an oblique projection view of the restraining clip with leash portion of FIG. 11 installed on a tubing line, according to embodiments of the disclosed subject matter.

DETAILED DESCRIPTION

Various mechanisms and methods for preventing the accidental decoupling of connectors are disclosed herein. In embodiments, a restraining member to prevent disconnection can apply a biasing force against opposite ends of the connector assembly, thereby urging the connectors together and against separation. The restraining member may include openings and/or recesses through which tubing lines connected to the connector assembly may pass. In embodiments, additional anti-separation components may also be provided in the restraining member. For example, the restraining member may include a protrusion, recess, or other appropriately arranged portion to interact with a portion of the connector assembly, e.g., a rotatable portion of the connector assembly to prevent rotation thereof.

In FIGS. 1-8, an embodiment of a restraining member for a tubing connector assembly is shown. A monolithic member forms a restraining clip 100, which can serve as a fluid line safety device for inhibiting inadvertent disconnection of a connector assembly. The restraining clip 100 can have an undulating shape with

curved forked ends 104 and a slot or recess 120 between the tines of the forked ends. The restraining clip 100 may be formed of a resilient material, such as a polymer. However, other materials for restraining clip 100 are also possible according to one or more contemplated embodiments.

The shape of the forked ends 104 permits the restraining clip 100 to accommodate the ends of interconnected tube segments, as illustrated in FIGS. 7-8. The forked ends 104 may be connected together by an undulating bridge, which includes an inwardly arching portion 114. The inwardly arching portion 114 has a knife edge bump 110 that engages a knurled attachment member 202 of the connection assembly. The interaction between the bump 110 and the attachment member 202 may prevent, or at least inhibit, it from rotating. A reinforcement bulge 102 ensures that the forked end 104 maintains a curved shape such that the forked ends 104 pushes against the connector ends 204 and 206 while maintaining contact of the knife edge bump 110 with the knurled attachment member 202.

In some luer connectors, the male luer 206 may have a rotating member 206. The female luer 204 may have a shape, for example, with flats or recesses, which interacts with the surface of the forked end 104 so as to keep it from rotating. Alternatively, or additionally, the size and shape of slot 120 may be chosen so as to grip an attached tube 212 from opposing sides. For example, the slot 120 may have a progressively narrowing shape. Portions indicated at 112 and 116 may stiffen the overall structure of the restraining clip 100.

Opposing surfaces of the opposite forked ends 104 may be provided with recesses into which the connector ends 204 and 206 fit. The size of the restraining clip 100 may be chosen such that an urging force is applied thereby forcing the connector ends 204, 206 together even when they are fully engaged. The photo of

FIG. 8 shows how the restraining clip 100 can be deformed when in position to hold the connectors – in the illustrated example, luer connectors – together. The deformation can produce a restoring force that urges the parts together, even when the connectors are otherwise fully connected. The curved shape of the forked ends 104 also help to provide a force urging the knurls of attachment member 202 against knife edge bump 110 while the forked ends 104 are urged together by the restoring force of the restraining clip 100.

To use the restraining clip 100, the forked ends 104 are spread apart. This can be done with two hands or with one. For example, to apply the restraining clip 100 to a connection assembly using one hand, two fingers of the left or right hand are inserted into narrow loops 140 and squeezed together, thereby actuating the forked ends 104 away from each other. The restraining clip 100 is then placed into position about the connection assembly with each forked end 104 adjacent to a respective connector end of the connection assembly, at which time the narrow loops 140 are released. By virtue of the resiliency of the restraining clip 100, a biasing force is thus applied to the ends of the connectors of the connection assembly thereby urging the connectors together, as shown in FIG. 8. Exemplary dimensions for the restraining clip are shown in FIGS. 2, 4, and 5. However, such dimensions are for illustration purposes only and are not limiting of the sizes and shapes for embodiments of the restraining clip according to the present disclosure.

FIG. 9 shows an alternative embodiment 300 based on a scissor-type mechanism. An elastic band 308 generates a force to urge two curved forked ends 302 together. A knife edge bump 310 on a resiliently deformable circular member 304 is urged against the knurled male luer cap 202. The halves of the scissor mechanism and the circular member 304 are retained by a hinge pin 306. Handles

325 permit the device to be engaged and released with a single hand by pinching the handles 325 together.

In some applications, such as medical treatment applications, it may be desirable to use a new restraining clip for each new connection so as to insure reliability of the new connection that may otherwise be compromised by reuse of the restraining clip. To prevent reuse of the restraining clip, the restraining clip may be semi-permanently or permanently coupled with a single-use or disposable tubing line. Discarding the used tubing line would also discard the used restraining clip in favor of a new tubing line with a new restraining clip.

Referring to FIGS. 10-13, an alternative embodiment for a restraining clip according to the present disclosure is shown, which may be used in the above-described applications. Restraining clip 100a is similar to the restraining clip 100 illustrated in FIGS. 1-8; however, while one end 104 of restraining clip 100a retains the forked configuration with slot 120, the other end 104a has a closed opening 120a. For example, tines of one of the forked ends 104 in FIGS. 1-8 can be joined together by an attachment portion to enclose one end of opening 120a.

The recess 120a may be sized and shaped so as to accommodate a tubing line therethrough. The recess 120a may also be sized and shaped to prevent connector 204 (or 206) from passing therethrough. When installed on a tubing line 212, the connector 204 (or 206) would prevent the restraining clip 100a from being removed from the tubing line 212. To assemble the tubing line with the restraining clip, the tubing line 212 may be passed through opening 120a of the restraining clip 100a prior to installing the connector 204 (or 206) on the tubing line. End 104a thus forms a leash that attaches or secures the restraining clip 100a to one of the tubing lines 212, such that the restraining clip 100a can only be used with that tubing line.

Replacement of the tubing line necessarily requires replacement of the restraining clip 100a. In an example, tubing line 212 is a blood tubing line for use in extracorporeal blood tubing sets.

Of course, other configurations for coupling the restraining clip to the tubing line such that both the tubing line and the restraining clip must be replaced together are also possible according to one or more contemplated embodiments. For example, the restraining clip could include a separate leash portion, either integrally formed as a part of the restraining clip or as a separate piece, which secures the restraining clip to a particular tubing line. In another example, the restraining clip leash portion may be formed as part of one of the connectors or permanently attached to one of the connectors of the connector assembly.

In any of the embodiments disclosed herein, the type of connector could be a luer-type connector or any other connector which relies on mutually rotatable parts on the connecting elements and/or which slide apart to disconnect. Also, although inline connectors are shown for purposes of illustration, the disconnect protection features shown can be applied to other types of connectors, such as, but not limited to connectors forming parts of junctions, components such as valves or filters, or others.

Features of the disclosed embodiments may be combined, rearranged, omitted, etc., within the scope of the present disclosure to produce additional embodiments. Furthermore, certain features may sometimes be used to advantage without a corresponding use of other features.

It is, thus, apparent that there is provided, in accordance with the present disclosure, fluid line safety devices, mechanisms, and methods. Many alternatives, modifications, and variations are enabled by the present disclosure. While specific embodiments have been shown and described in detail to illustrate the application of

the principles of the invention, it will be understood that the invention may be embodied otherwise without departing from such principles. Accordingly, Applicants intend to embrace all such alternatives, modifications, equivalents, and variations that are within the spirit and scope of the present invention.

CLAIMS

1. A restraining device, comprising:
 - a resilient member having a generally U-shape with forked ends that curve toward each other;
 - each forked end having a recess between tines thereof, each recess having a blind end;
 - a bend in the resilient member being provided with an engagement bump;
 - the engagement bump and forked ends being aligned such that the engagement bump coincides with a line joining the blind ends,
 - wherein, when a cylindrical connector assembly tube is placed in the recesses, the engagement bump is urged against a side of the connector assembly.
2. The device of claim 1, wherein the engagement bump is provided on a U-shaped portion that is opposite and in the middle of the general U-shape of the resilient member.
3. The device of claim 1, wherein the resilient member is made of a polymer.
4. A restraining member for a connector assembly comprising:
 - a forked first end having a first recess between tines thereof, the first recess being sized and shaped so as to accept a first tubing connected to one end of the connector assembly;
 - a closed second end having an opening therein, the second end being sized and shaped so as to accept a second tubing connected to an other end of the connector assembly; and
 - a bend with an engagement bump arranged between the first and second ends,

wherein the bend is arranged such that, when the first and second ends abut against respective first and second ends of the connector assembly, the engagement bump interacts with a knurled attachment member so as to inhibit rotation thereof.

5. The restraining member of claim 4, wherein the member is made of a polymer.

6. A tubing set comprising:

a restraining member including:

a forked first end having a first recess between tines thereof;

a closed second end having an opening therein; and

a bend with an engagement bump arranged between the first and second ends;

a tubing line passing through the opening in the closed second end of the restraining member; and

a connector attached to an end of said tubing line.

7. The tubing set of claim 6, wherein the connector is one of a male luer-type connector and a female luer-type connector.

8. The tubing set of claim 6, wherein the tubing line is a blood tubing line.

9. A restraining member for a connector assembly comprising:

a first end having a first U-shaped recess therein, the first recess being sized and shaped so as to accept a first tubing connected to one end of the connector assembly;

a second end having an opening therein, the second end being sized and shaped so as to accept a second tubing connected to an other end of the connector assembly;

a bridge connecting the first and second ends, the bridge having a bend therein with an engagement bump; and

an attachment portion configured to secure the restraining member to the second tubing such that the restraining member cannot be used with another second tubing.

10. The restraining member of claim 9, wherein the bend is arranged such that, when the first and second ends abut against respective first and second connector assembly ends, the engagement bump interacts with a knurled attachment member to inhibit rotation thereof.

11. The restraining member of claim 9, wherein the attachment portion includes a portion that closes the second end opening.

12. The restraining member of claim 9, wherein the attachment portion includes a separate leash portion.

13. A restraining member for a connector assembly for first and second tubes having mating connectors thereon, one of the mating connectors having a locking collar that locks the other of the mating connectors, the restraining member comprising:

first and second ends shaped to capture and position first and second mating connector parts attached to the first and second tubes, respectively; and

a flexible bridge portion connecting the first and second ends shaped such that when the first and second mating connector parts are connected, the first and second ends are urged together thereby urging the first and second mating connectors together,

wherein the flexible bridge portion has an engagement element with an edge that captures and immobilizes the locking collar.

14. The restraining member of claim 13, wherein the locking collar is knurled and the engagement element is a knife-edged bump.

15. The restraining member of claim 13, wherein the locking collar is knurled, the engagement element is a knife-edged bump, and the flexible bridge portion is shaped

so as to urge the bump toward the knurled collar in a radial direction while restraining the locking collar against a force generated thereby.

16. A restraining device, comprising:

a resilient member having a generally U-shape with forked ends that curve toward each other;

each forked end having a recess between tines thereof;

the forked ends having facing bowl shapes;

a bend in the resilient member being provided with an engagement bump;

the engagement bump and forked ends being aligned such that the engagement bump coincides with a line joining the facing bowl shapes, whereby when a cylindrical connector assembly tube is placed in the recesses the engagement bump is urged against a side of the connector assembly.

17. The device of claim 16, wherein the engagement bump is provided on a U-shaped portion that is opposite and in the middle of the general U-shape of the resilient member.

18. The device of claim 16, wherein the resilient member is made of polymer.

19. A device configured to urge mating connectors together while simultaneously resiliently urging an engagement member into at least one of the mating connectors such that, by said urging an engagement member, said at least one of the mating connectors is prevented from rotating.

20. The device of claim 19, further comprising engagement elements that are urged together and configured to engage ends of the mating connectors.

21. Any physically-realizable device that results from any combination of features recited in any of the preceding claims.

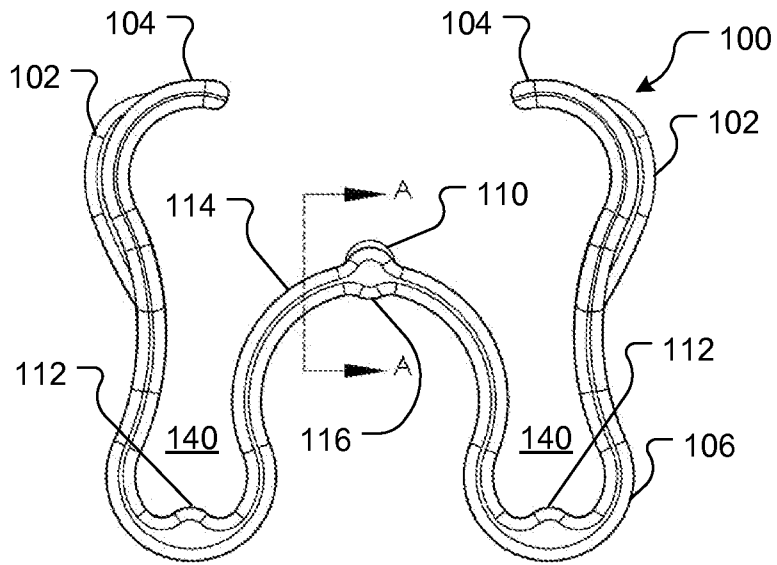

FIG. 1

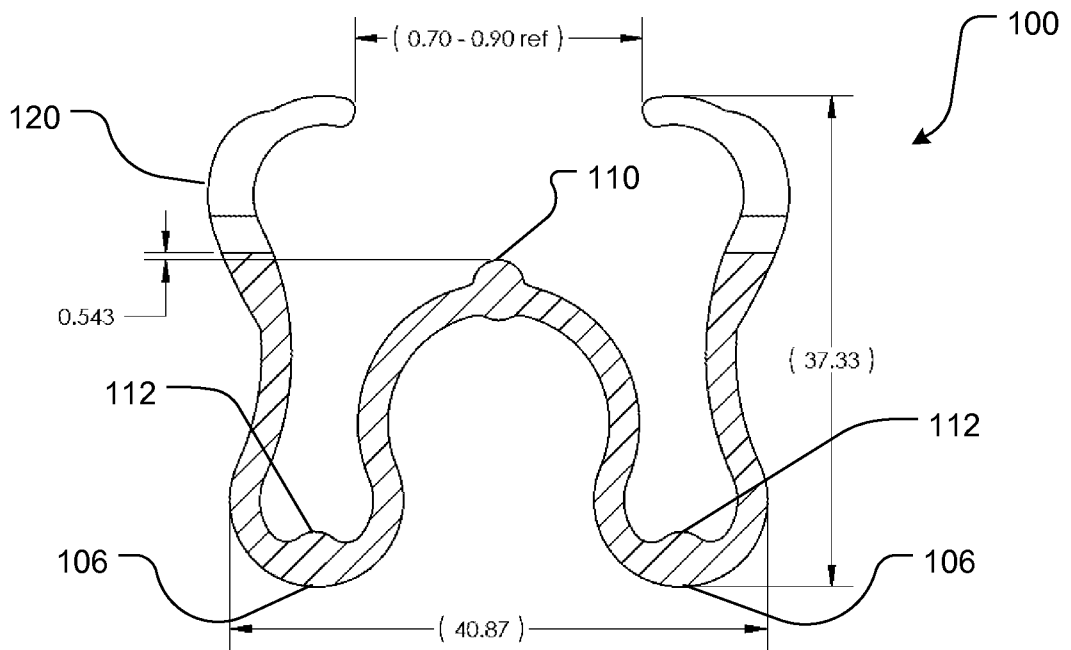

FIG. 2

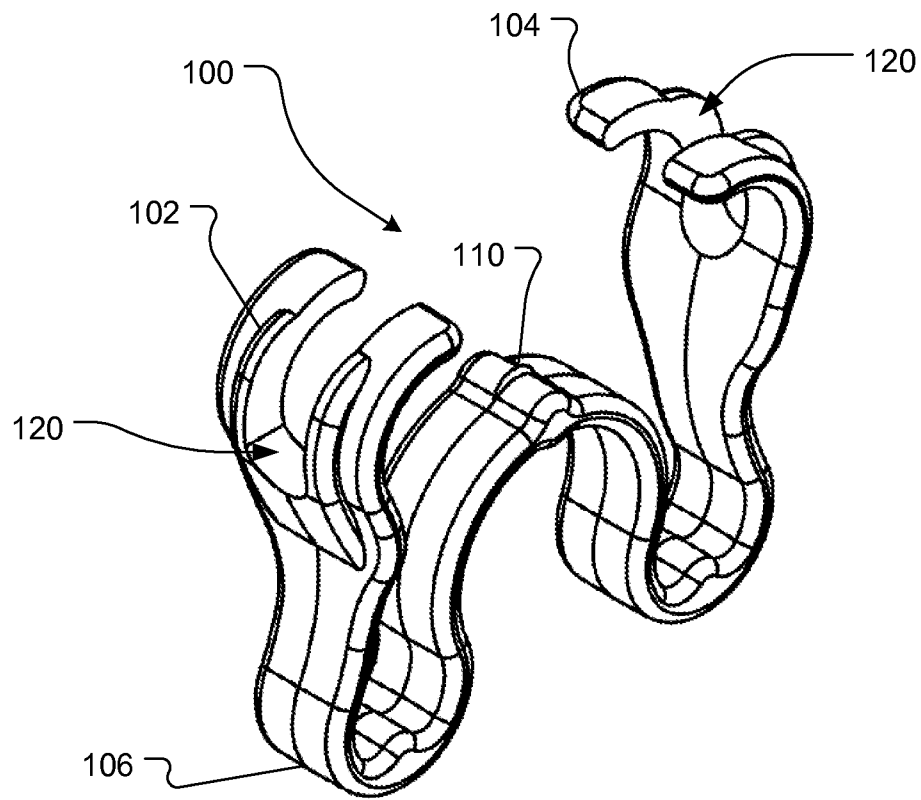

FIG. 3

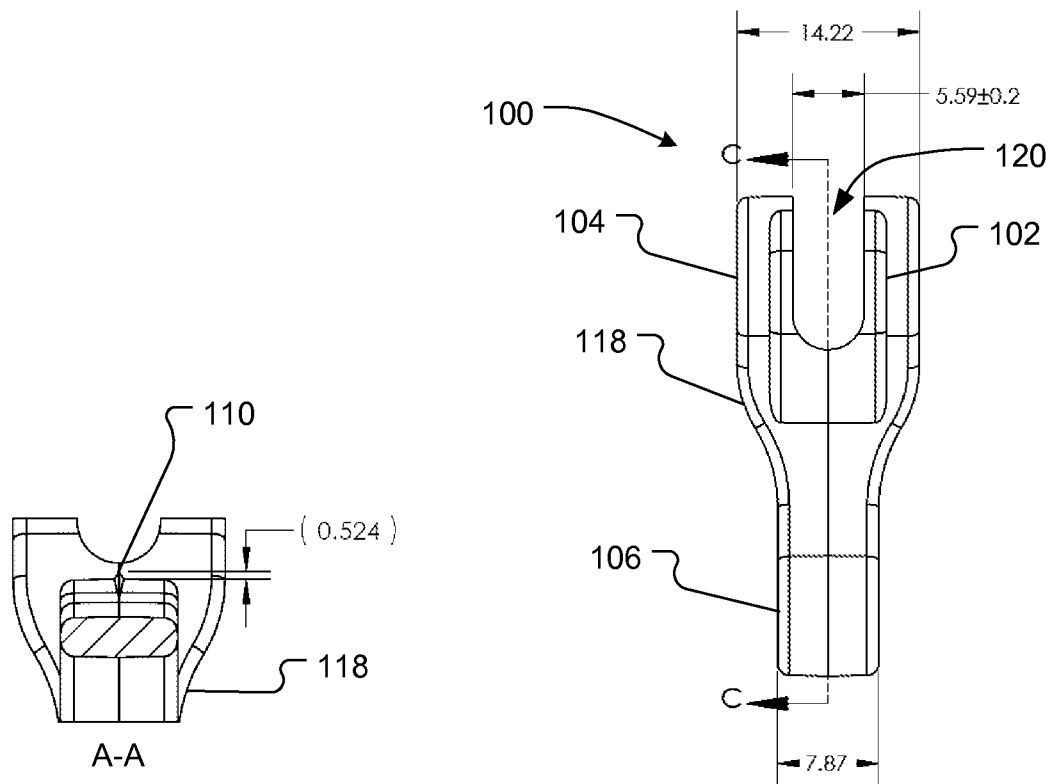

FIG. 4

FIG. 5

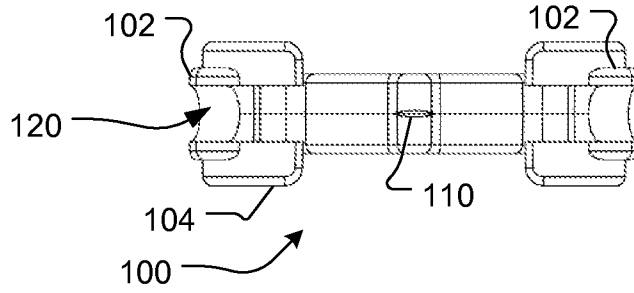

FIG. 6

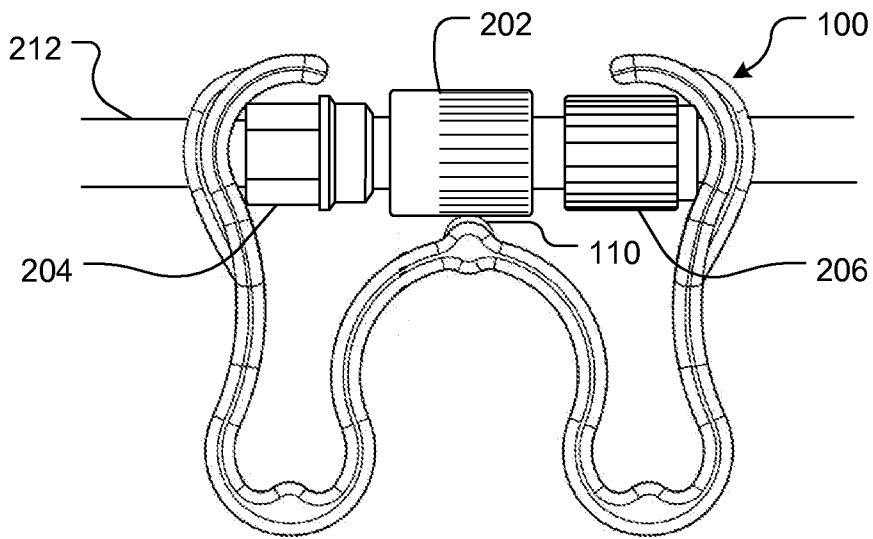

FIG. 7

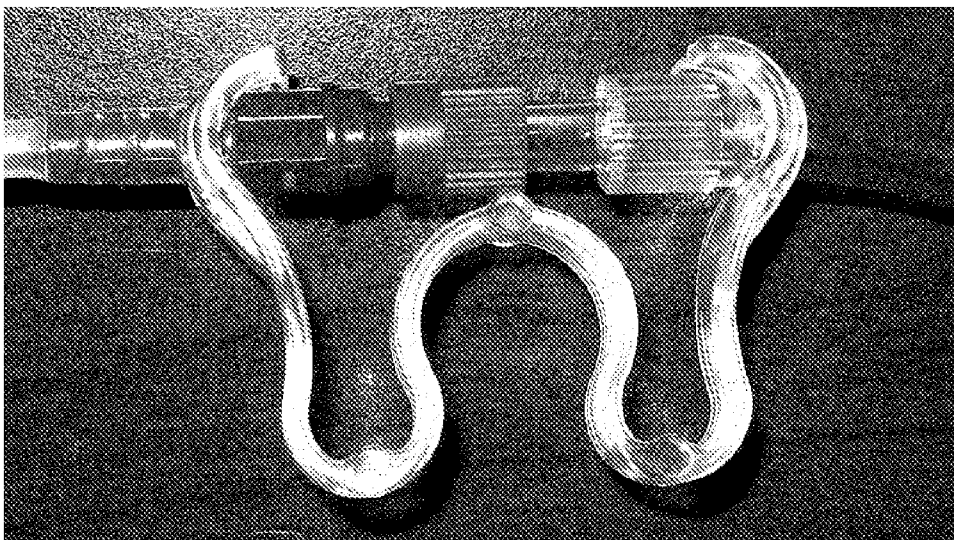

FIG. 8

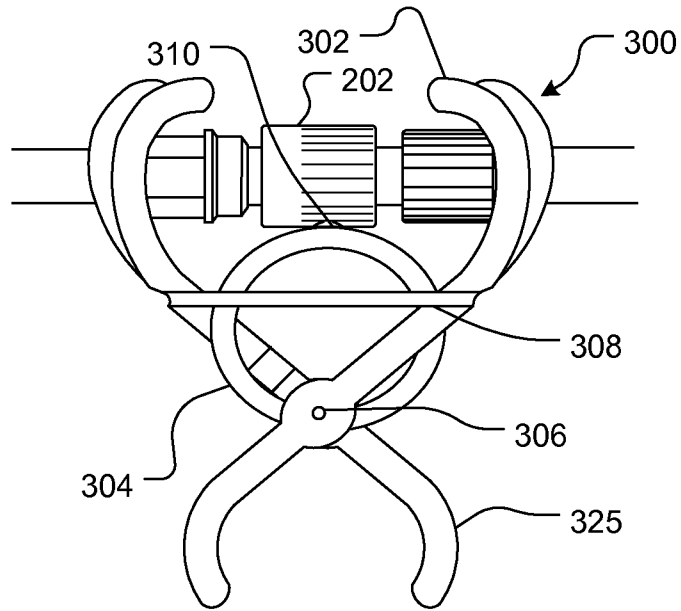

FIG. 9

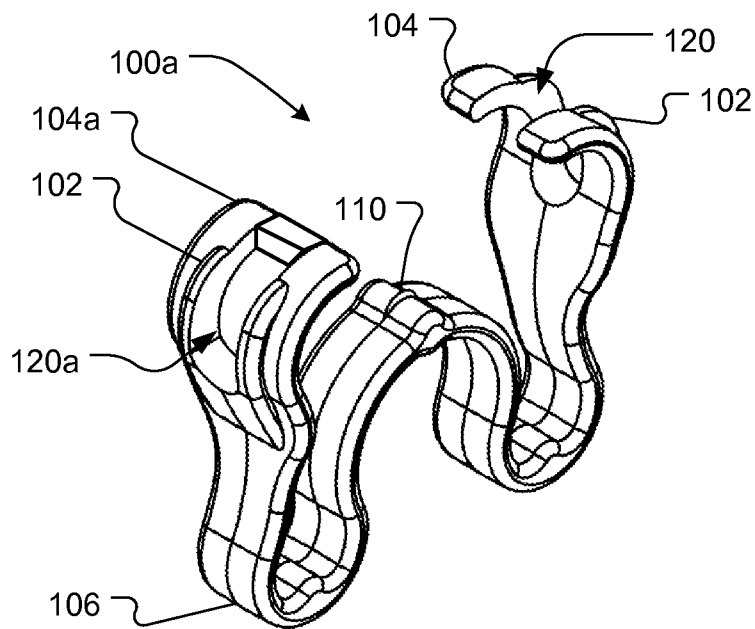

FIG. 10

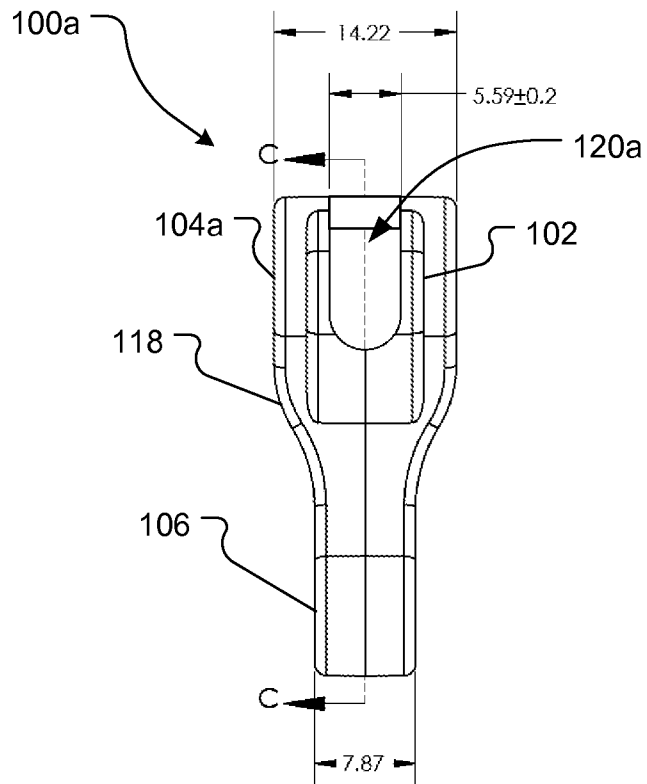

FIG. 11

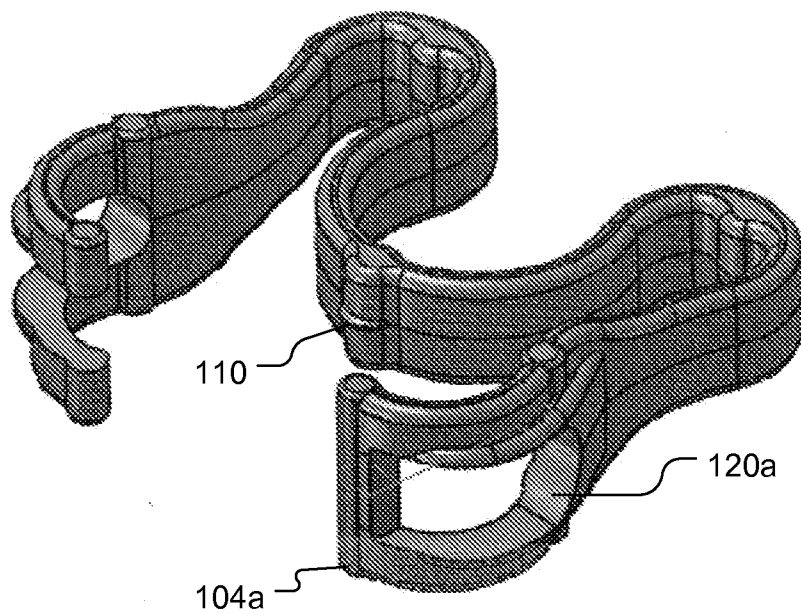

FIG. 12

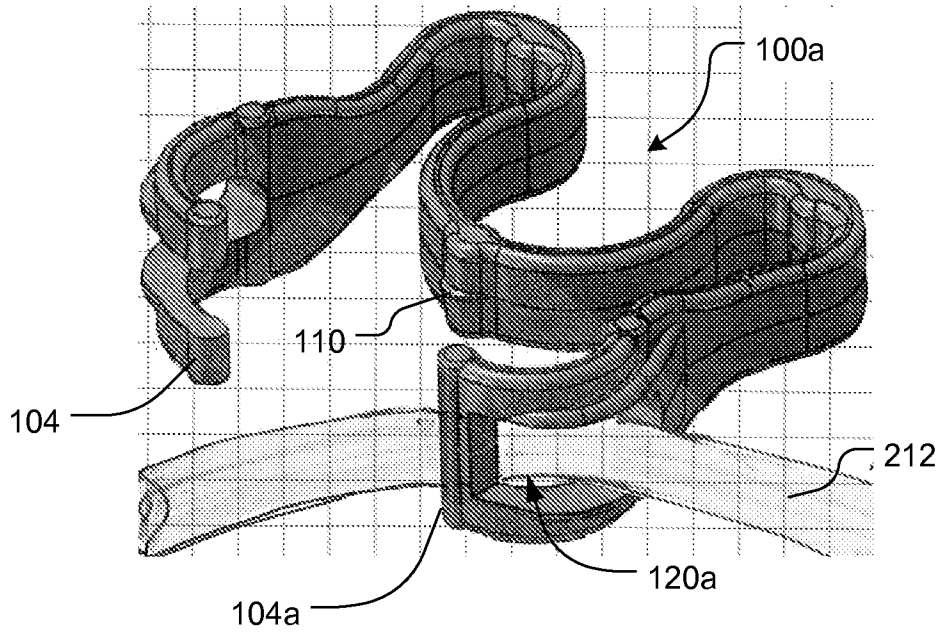

FIG. 13

INTERNATIONAL SEARCH REPORT

International application No.
PCT/US2010/054112

A. CLASSIFICATION OF SUBJECT MATTER IPC(8) - A61M 39/10 (2010.01) USPC - 604/241 According to International Patent Classification (IPC) or to both national classification and IPC		
B. FIELDS SEARCHED Minimum documentation searched (classification system followed by classification symbols) IPC(8) - A61M 39/10; F16L 37/08, 37/12, 55/00 (2010.01) USPC - 285/81, 92, 330, 902, 903; 403/220, 326; 604/241, 535, 905 Documentation searched other than minimum documentation to the extent that such documents are included in the fields searched Electronic data base consulted during the international search (name of data base and, where practicable, search terms used) PatBase		
C. DOCUMENTS CONSIDERED TO BE RELEVANT		
Category*	Citation of document, with indication, where appropriate, of the relevant passages	Relevant to claim No.
X -- Y Y Y	US 2008/0129042 A1 (WEIGEL et al) 05 June 2008 (05.06.2008) entire document US 3,340,704 A (SECKERSON) 12 September 1967 (12.09.1967) entire document US 3,881,753 A (BOCHORY) 06 May 1975 (06.05.1975) entire document	19, 21 ----- 1-18, 20 1-18, 20 1-8, 16-18
<input type="checkbox"/> Further documents are listed in the continuation of Box C. <input type="checkbox"/>		
* Special categories of cited documents: "A" document defining the general state of the art which is not considered to be of particular relevance "E" earlier application or patent but published on or after the international filing date "L" document which may throw doubts on priority claim(s) or which is cited to establish the publication date of another citation or other special reason (as specified) "O" document referring to an oral disclosure, use, exhibition or other means "P" document published prior to the international filing date but later than the priority date claimed "T" later document published after the international filing date or priority date and not in conflict with the application but cited to understand the principle or theory underlying the invention "X" document of particular relevance; the claimed invention cannot be considered novel or cannot be considered to involve an inventive step when the document is taken alone "Y" document of particular relevance; the claimed invention cannot be considered to involve an inventive step when the document is combined with one or more other such documents, such combination being obvious to a person skilled in the art "&" document member of the same patent family		
Date of the actual completion of the international search 08 December 2010	Date of mailing of the international search report <div style="text-align: center; font-size: 1.2em; font-weight: bold;">22 DEC 2010</div>	
Name and mailing address of the ISA/US Mail Stop PCT, Attn: ISA/US, Commissioner for Patents P.O. Box 1450, Alexandria, Virginia 22313-1450 Facsimile No. 571-273-3201	Authorized officer: Blaine R. Copenheaver PCT Helpdesk: 571-272-4300 PCT OSP: 571-272-7774	