

(19) World Intellectual Property Organization  
International Bureau



(43) International Publication Date  
1 March 2007 (01.03.2007)

PCT

(10) International Publication Number  
**WO 2007/024152 A2**

(51) International Patent Classification:  
A61B 5/151 (2006.01)

Warszawa (PL). NOWICKI, Adam [PL/PL]; ul. Wirskiego 4 m. 10, PL-22-100 Chelm (PL).

(21) International Application Number:  
PCT/PL2006/000057

(74) Agent: "HTL-STREFA" SPOLKA AKCYJNA; ul. Daniszewska 4, PL-03-230 Warszawa (PL).

(22) International Filing Date: 24 August 2006 (24.08.2006)

(81) Designated States (unless otherwise indicated, for every kind of national protection available): AE, AG, AL, AM, AT, AU, AZ, BA, BB, BG, BR, BW, BY, BZ, CA, CH, CN, CO, CR, CU, CZ, DE, DK, DM, DZ, EC, EE, EG, ES, FI, GB, GD, GE, GH, GM, HN, HR, HU, ID, IL, IN, IS, JP, KE, KG, KM, KN, KP, KR, KZ, LA, LC, LK, LR, LS, LT, LU, LV, LY, MA, MD, MG, MK, MN, MW, MX, MY, MZ, NA, NG, NI, NO, NZ, OM, PG, PH, PL, PT, RO, RS, RU, SC, SD, SE, SG, SK, SL, SM, SV, SY, TJ, TM, TN, TR, TT, TZ, UA, UG, US, UZ, VC, VN, ZA, ZM, ZW.

(25) Filing Language: English

(26) Publication Language: English

(30) Priority Data:  
P.376 767 25 August 2005 (25.08.2005) PL

(71) Applicant (for all designated States except US): "HTL-STREFA" SPOLKA AKCYJNA [PL/PL]; ul. Adamowek 7, PL-95-935 Ozorkow (PL).

(84) Designated States (unless otherwise indicated, for every kind of regional protection available): ARIPO (BW, GH, GM, KE, LS, MW, MZ, NA, SD, SL, SZ, TZ, UG, ZM, ZW), Eurasian (AM, AZ, BY, KG, KZ, MD, RU, TJ, TM), European (AT, BE, BG, CH, CY, CZ, DE, DK, EE, ES, FI,

(72) Inventors; and

(75) Inventors/Applicants (for US only): JANKOWSKI, Andrzej [PL/PL]; ul. Sucharskiego 4 m. 74, PL-01-390

[Continued on next page]

(54) Title: A PATIENT'S SKIN PUNCTURING DEVICE

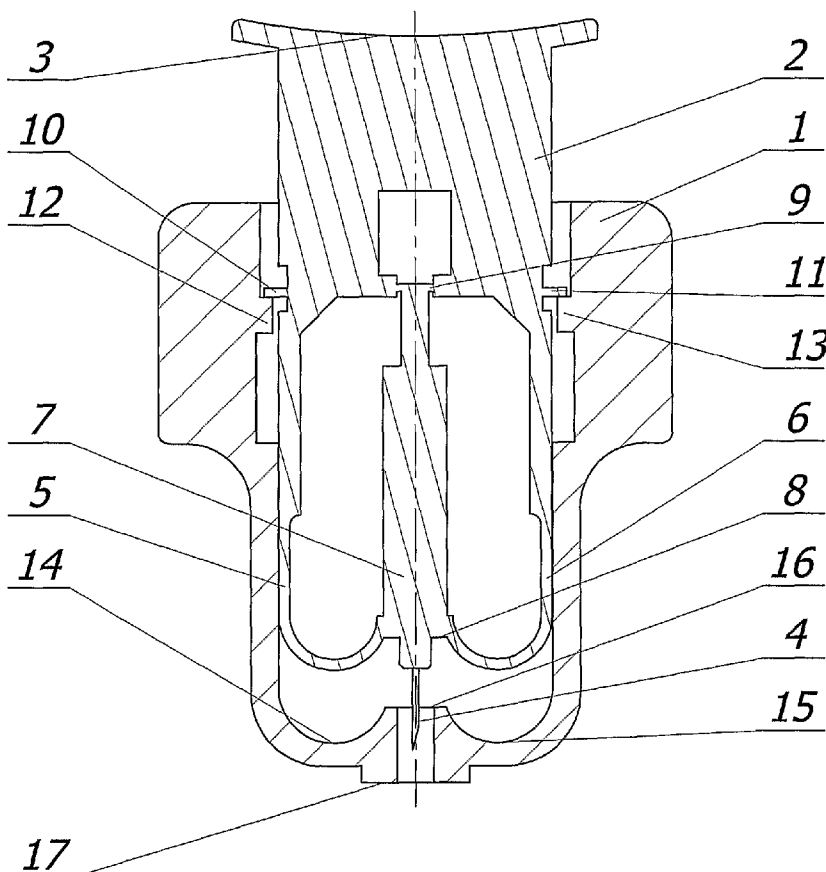

(57) Abstract: A patient's skin puncturing device comprises a body (1), inside of which a puncturing needle (4) and at least one turned down arm (5, 6) are guided, and a push button (2), whereas between said body (1) and said push button (2) activating elements (10, 11, 12, 13) are placed, said activating elements (10, 11, 12, 13) enable to force said push button (2) into said body (1) when a pre-set thrust force is exceeded. The puncturing needle (4) is driven by said push button (2) by means of a membrane (9), which is broken after resting the puncturing needle (4) upon an abutting surface (16) in said body (1). After breaking the membrane (9) and the patient's skin puncture by the puncturing needle (4), the puncturing needle (4) is withdrawn inwards the body (1) due to a transfer of a thrust force from the push button (2) by said turned down arm (5, 6) guided in the body (1).

WO 2007/024152 A2



FR, GB, GR, HU, IE, IS, IT, LT, LU, LV, MC, NL, PL, PT,  
RO, SE, SI, SK, TR), OAPI (BF, BJ, CF, CG, CI, CM, GA,  
GN, GQ, GW, ML, MR, NE, SN, TD, TG).

— of inventorship (Rule 4.17(iv))

**Declarations under Rule 4.17:**

- as to applicant's entitlement to apply for and be granted a patent (Rule 4.17(ii))
- as to the applicant's entitlement to claim the priority of the earlier application (Rule 4.17(iii))

**Published:**

- without international search report and to be republished upon receipt of that report

For two-letter codes and other abbreviations, refer to the "Guidance Notes on Codes and Abbreviations" appearing at the beginning of each regular issue of the PCT Gazette.

## A Patient's skin puncturing device

### Technical Field

The subject of the invention is a patient's skin puncturing device, particularly for collecting blood samples for diagnostic purposes.

5

### Background Art

From the USA patent publication No. 5,356,420 a puncturing device is known comprising a sleeve and a push button positioned at one sleeve end. The other sleeve end terminates with a bottom with an opening therein. Inside the sleeve a piston is slidably positioned, terminating with a push rod at the end closer to the push button, and with a puncturing tip at the end closer to the bottom opening. Inside the sleeve, between the push button face and the piston a drive spring is located, and between the piston and the sleeve bottom a return spring is placed. The piston comprises wings located on its outer perimeter, which wings rest on an internal projection of the sleeve, and when the device is used, the wings get broken, and subsequent re-use of the device is not possible.

15

In the US patent description No. 5,439,473 is disclosed a lancet designed for puncturing the patient's skin for collecting small blood samples. The lancet has an elongated body wherein a movable member is placed slidingly along the body axis, while the body has a top opening for the lancet push button, and a bottom opening for the piercing blade. The movable member consists of a flat spring, one end of which is joined to the push button. The push button has two upper arms perpendicular to its surface, and these arms have hooked ends placed in oblong openings of the body side walls. The other end of the movable member flat spring is joined with a holder wherein the piercing blade is fixed. The lower portion of the holder has two lower arms parallel to the upper arms. The lower arms have, moreover, upwardly directed, triangle shaped ends, which rest upon the lower edges of the oblong openings of the body walls. All parts of the movable member are made of plastic.

20

25

When the patient's skin is being punctured, the lancet push button is pressed, so the flat spring of the movable member is tensed, and hooked ends of the upper arms press against the ends of the lower arms of the movable member. Next, the lower arms get released, the flat spring rebounds, and the patient's skin is punctured by the piercing blade, which passes

30

through the body bottom opening. After puncturing the skin, the flat spring assumes its free position, and the piercing blade retracts into the inside of the lancet body.

### **Disclosure of Invention**

5           The purpose of this invention is to provide a patient's skin puncturing device, which is safe, both for the patient and for service personnel, simple and cheap, with a structure of a minimal number of components and devoid of driving and return springs and thus devoid of disadvantageous aspects connected with a presence of the springs in the puncturing devices.

10           The next purpose of this invention is to provide the patient's skin puncturing device with the structure, which guarantees getting a required minimal puncture energy and which enables the user, depending on needs, to regulate intuitively an energy of the puncture by a regulation of a speed of the pressure exerted by the user's finger on the push button.

15           The next purpose of this invention is to provide a patient's skin puncturing device of the structure forcing a reliable withdrawal of the needle from a wound without an increase in a number of device elements.

20           The essence of the patient's skin puncturing device according to the present invention built of a body, inside of which a puncturing needle and at least one turned down arm are guided, and a push button, whereas between the body and the push button activating elements are placed, and the activating elements enable to force the push button into the body when a pre-set thrust force is exceeded, is that the puncturing needle is driven by the push button by means of a membrane, which is broken after resting the puncturing needle upon an abutting surface in said body.

25           The essence of a variety of the patient's skin puncturing device, according to the invention, built of a body, inside of which a puncturing needle and at least one turned down arm are guided, and a push button, whereas between the body and the push button activating elements are placed, and the activating elements enable to force the push button into the body when a pre-set thrust force is exceeded, is that after breaking the membrane and the patient's skin puncture by the puncturing needle, the puncturing needle is withdrawn inwards the body due to a transfer of a thrust force from the push button by said turned down arm guided in the body.

30           Preferably, the patient's skin puncturing device, according to the invention, comprises a pair of turned down arms.

Preferably, the push button and the turned down arm constitute one component.

Preferably, the push button, the turned down arm and the sprayed round puncturing needle constitute one component.

5 Preferably, the push button has on its outer surface activating wings, which abut against internal protrusions in the body.

The advantage of the patient's skin puncturing device according to the invention is that it has the simplified two-components construction, which ensures the needle to be driven directly by the push button both during a puncture movement and during a needle withdrawal movement.

10 The lack of the driving and return springs eliminates all technical problems connected with their application in the known puncturing devices.

While usage of the patient's skin puncturing device according to the invention, the puncture takes place under the pressure of the user's finger, whereas the minimal puncture energy is guaranteed by a structurally determined value of a boundary pressure, which is  
15 connected with a value of a boundary force required to overcome a resistance protecting against the push button movement in the device body.

Simultaneously, depending on individual characteristics of the punctured skin, i.e. the skin thickness and hardness, the user can, by means of the regulation of the pressure speed, intuitively adjust the puncture energy transferred to the patient's body. Thus, the patient's skin  
20 puncturing device according to the invention guarantees to the user the certainty of the skin puncture, even in case of the very thick or hard skin.

The next advantage of the patient's skin puncturing device according to the invention is that it guarantees the certainty of the needle withdrawal when the skin is punctured and thereby ensuring a required operational safety of the device for the patient and for the medical  
25 personnel.

As a result, the solution of the patient's skin puncturing device according to the invention is safe while operation, structurally simple, cheap and easy in manufacture.

### **Brief description of drawings**

30 The subject of the invention is presented in an example embodiment on the drawings, where Fig. 1 shows the longitudinal view of the patient's skin puncturing device according to the invention, before its use, Fig. 2 – the device of Fig. 1 after breaking off activating

wings, Fig. 3 – the device of Fig. 1 at a phase with a needle maximally protruding from a body of the device, and Fig. 4 - the device of Fig. 1 after its use.

### Best Mode of Carrying Out the Invention

5           The patient's skin puncturing device according to the invention designed for collecting a sample of blood for diagnostic purposes, as shown in Fig. 1, is built of the body 1 and placed therein a push button 2. The push button 2 has a thrust face 3 in an upper portion and a puncturing needle 4 in a lower portion, whereas the upper and the lower portions of the push button 2 are, preferably, connected with each other by a pair of turned down and parallel to  
10 each other arms 5, 6 and by a support 7 placed in the axis of the push button 2. The support 7 has, respectively, a stop 8 of the puncturing needle 4 in the lower portion and a membrane 9 in the upper portion. Moreover, the push button 2 has on its outer surface two activating wings 10, 11, which abut against internal protrusions 12, 13 in the body 1. Further, underneath the turned down arms 5, 6 of the push button 2 the body 1 has inside two turned down surfaces 14, 15 and  
15 underneath the stop 8 of the puncturing needle 4 the body 1 has inside an abutting surface 16 of the stop 8 together with an opening for the puncturing needle 4 and from the side of the patient's skin a butting face 17.

Fig. 1 presents the device, according to the invention, in the standstill, it means before the activation, in which the two activating wings 10, 11 of the push button 2 rest on the internal  
20 protrusions 12, 13 of the body 1, the turned down arms 5, 6 are situated over the turned down surfaces 14, 15 of the body 1 and the puncturing needle 4 is situated in the body 1.

After applying to the thrust face 3 of the push button 2 a force, the value of which exceeds the boundary force determined by the construction of the device, the activating wings 10, 11 are broken off and, further, the push button 2 is moved downwards, the turned down  
25 arms 5, 6 bring closer to the turned down surfaces 14, 15 of the body 1 and the puncturing needle 4 moves progressively outside the body 1, as it is shown in Fig. 2.

During further movement of the push button 2, as it is shown in Fig. 3, the puncture of the patient's skin by the puncturing needle 4 is performed and the stop 8 of the puncturing needle 4 abuts against the abutting surface 16. At the same time, the turned down arms 5, 6 strain and abut  
30 against the turned down surfaces 14, 15 of the body 1. The puncturing needle 4 is then situated in the lowest position, what causes the maximal puncture of the patient's skin.

The next phase of the movement of the push button 2 is breaking the membrane 9 as result of turning down the arms 5, 6 upon the turned down surfaces 14, 15 of the body 1 and withdrawal the puncturing needle 4, as it is shown in Fig. 4. In consequence of this movement, the puncturing needle 4 retracts into the body 1 and does not protrude below the butting face 17 into the patient's skin thereby making the contact of the service personnel with the blood present on the needle impossible. The push button 2 is seized in the lower position by additional catches placed therein in order to make the moving of the puncturing needle 4 outside the body 1 as well as the contact with the blood collected impossible.

The device, according to the invention, is the disposable device insofar the broken off activating wings 10, 11 of the push button 2 make the subsequent use of the device impossible and the push button 2 is seized in the lower position.

**We claim:**

1. A patient's skin puncturing device comprising a body, inside of which a puncturing needle and at least one turned down arm are guided, and a push button, whereas between said body and said push button activating elements are placed, said activating elements enable to force said push button into said body when a pre-set thrust force is exceeded, characterized in that said puncturing needle (4) is driven by said push button (2) by means of a membrane (9), which is broken after resting the puncturing needle (4) on an abutting surface (16) in said body (1).
2. A patient's skin puncturing device comprising a body, inside of which a puncturing needle and at least one turned down arm are guided, and a push button, whereas between said body and said push button activating elements are placed, said activating elements enable to force said push button into said body when a pre-set thrust force is exceeded, characterized in that after breaking the membrane (9) and the patient's skin puncture by the puncturing needle (4), the puncturing needle (4) is withdrawn inwards the body (1) due to a transfer of a thrust force from the push button (2) by said turned down arm (5, 6) guided in the body (1).
3. A patient's skin puncturing device according to the claim 1 or 2, characterized in that it comprises a pair of turned down arms (5, 6).
4. A patient's skin puncturing device according to the claim 1 or 2, characterized in that the push button (2) and the turned down arm (5, 6) constitute one component.
5. A patient's skin puncturing device according to the claim 1 or 2, characterized in that the push button (2), the turned down arm (5, 6) and the sprayed round puncturing needle (4) constitute one component.
6. A patient's skin puncturing device according to the claim 1 or 2, characterized in that the push button (2) has on its outer surface activating wings (10, 11), which abut against internal protrusions (12, 13) in the body (1).



1 / 4

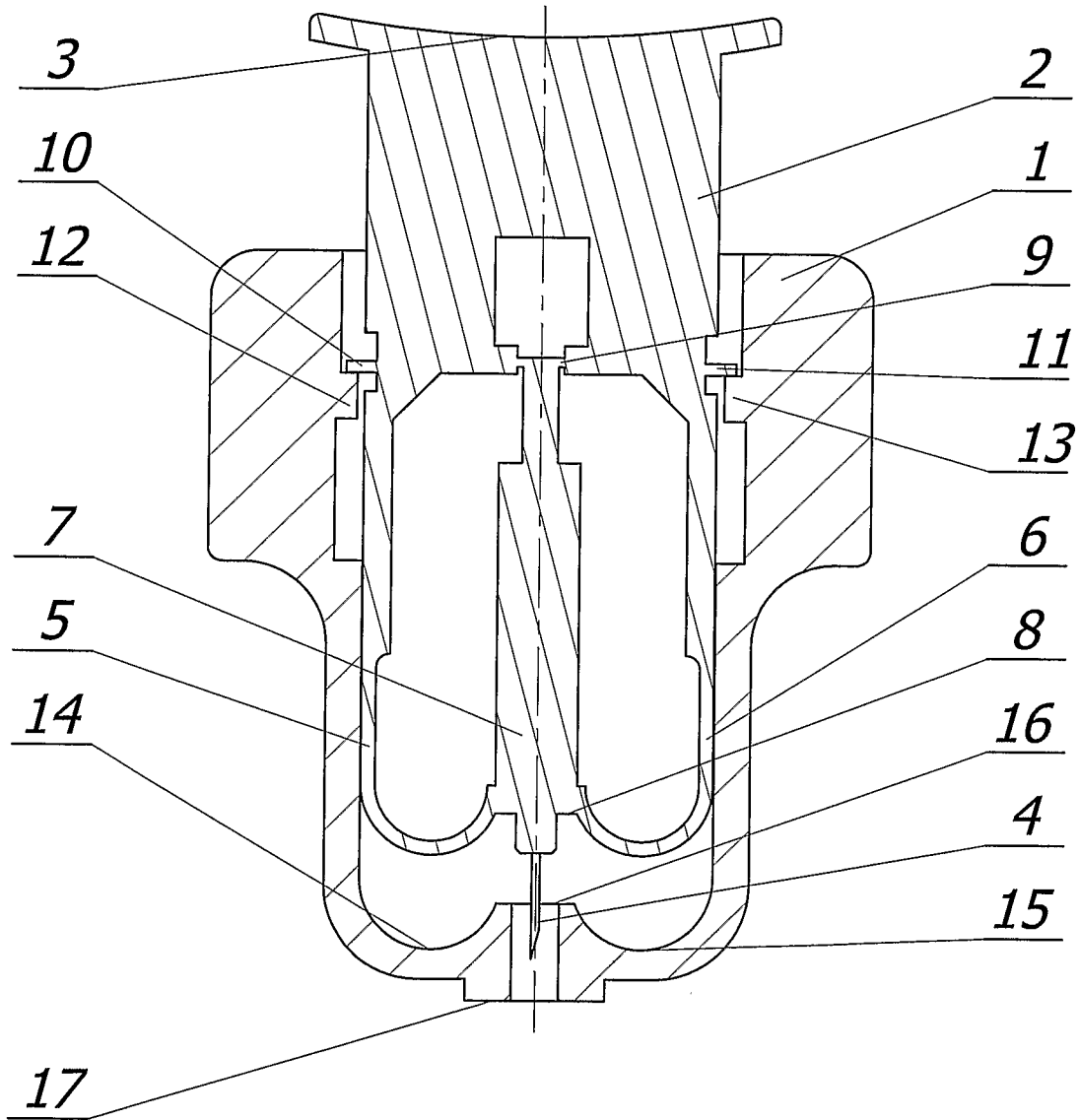

Fig. 1

2 / 4

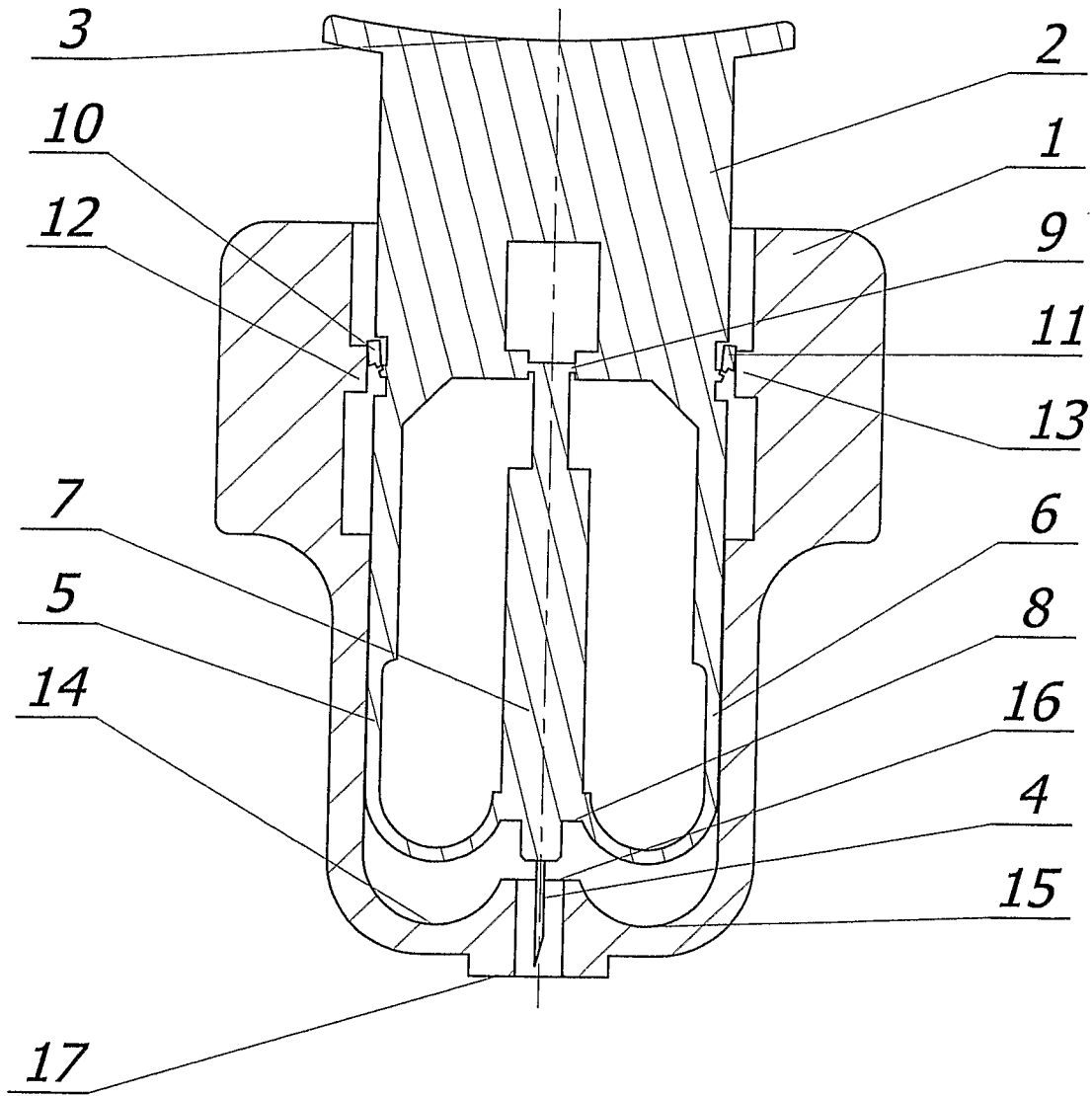

Fig.2

3 / 4

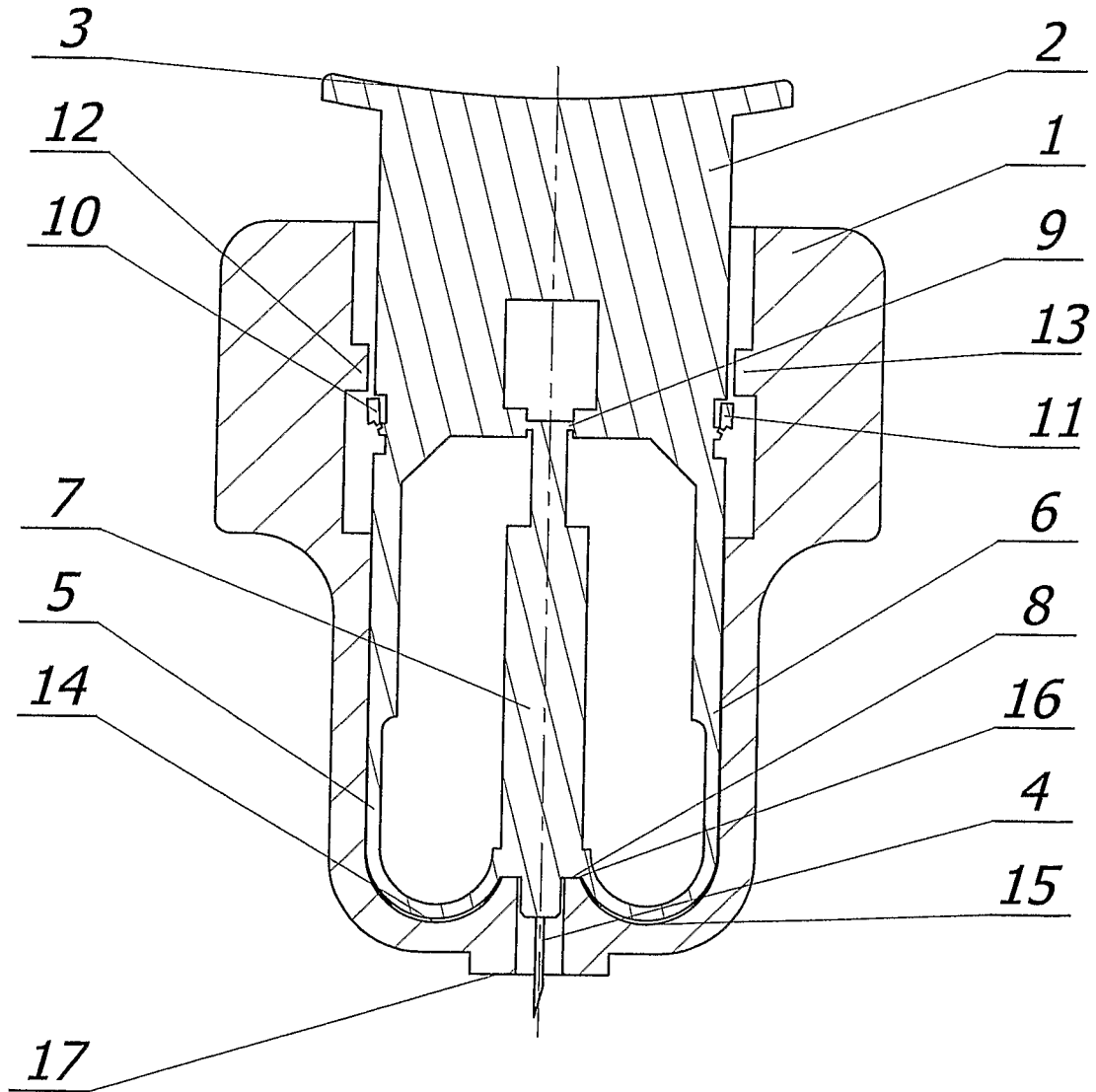

Fig.3

4 / 4

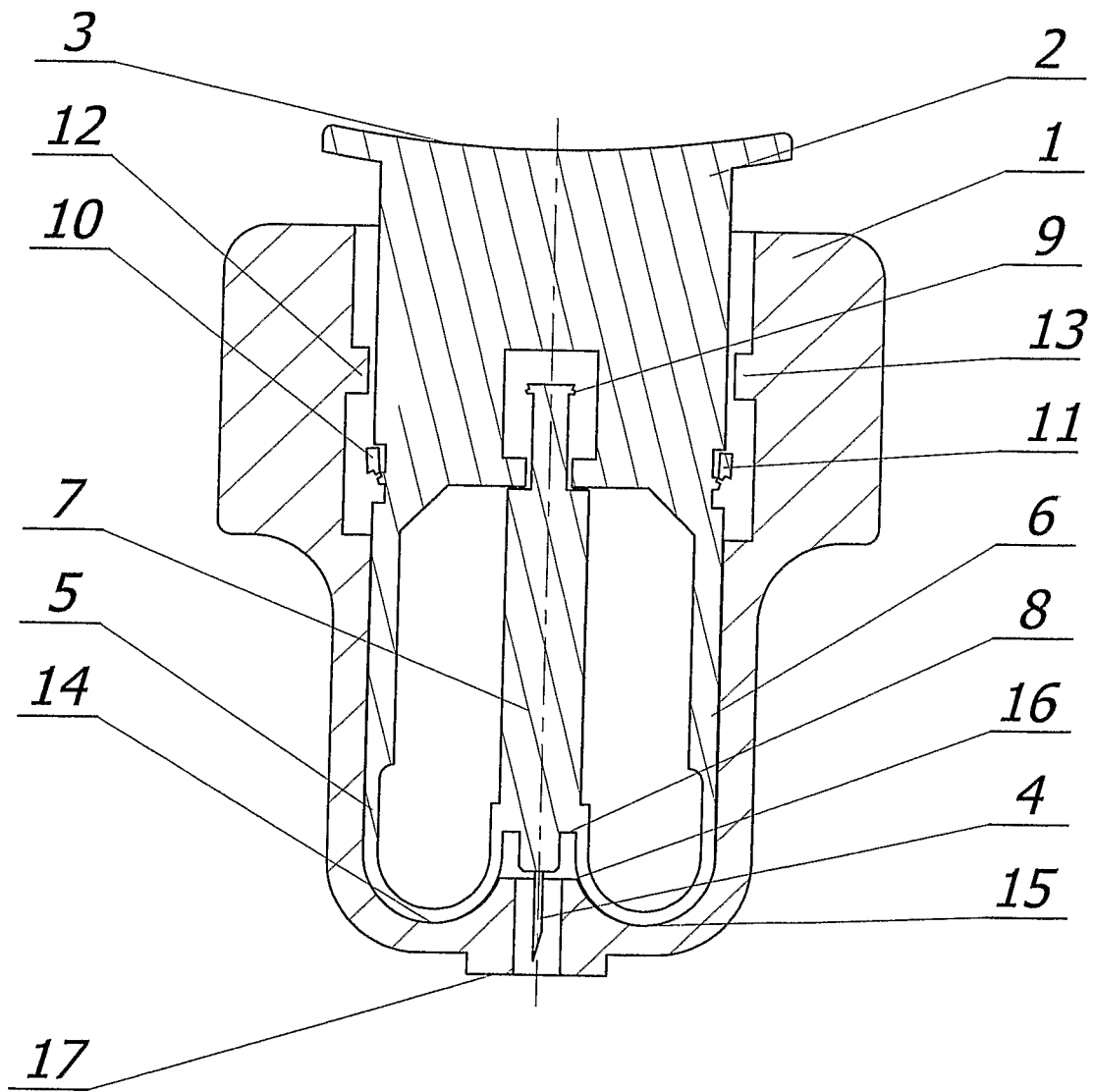

Fig.4