

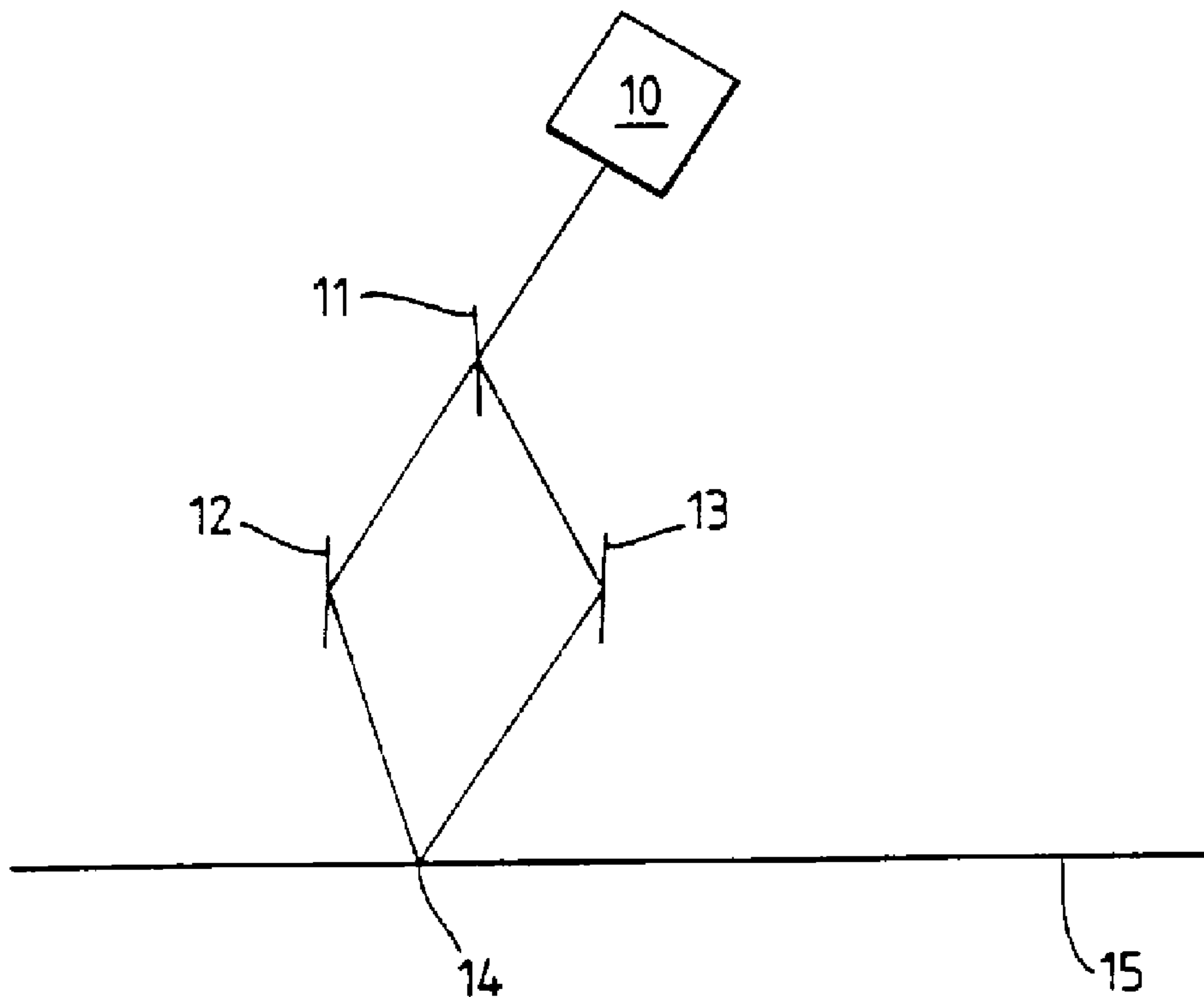

(22) Date de dépôt/Filing Date: 1993/06/24
 (41) Mise à la disp. pub./Open to Public Insp.: 1994/01/06
 (45) Date de délivrance/Issue Date: 2004/01/06
 (62) Demande originale/Original Application: 2 117 682
 (30) Priorité/Priority: 1992/06/24 (92305783.0) EP

(51) Cl.Int.⁶/Int.Cl.⁶ G02B 6/16, G02B 1/00
 (72) Inventeurs/Inventors:
 AINSLIE, BENJAMIN JAMES, GB;
 WILLIAMS, DOUGLAS LAWRENCE, GB;
 MAXWELL, GRAEME DOUGLAS, GB;
 KASHYAP, RAMAN, GB;
 ARMITAGE, JONATHAN RICHARD, GB
 (73) Propriétaire/Owner:
 BRITISH TELECOMMUNICATIONS PUBLIC LIMITED
 COMPANY, GB
 (74) Agent: GOWLING LAFLEUR HENDERSON LLP

(54) Titre : RESEAU DE DIFFRACTION PHOTOINDUIT DANS DU VERRE A L'OXYDE DE BORE
 (54) Title: PHOTOINDUCED GRATING IN B₂O₃ CONTAINING GLASS



(57) Abrégé/Abstract:

It has been demonstrated that B containing glasses are sensitive to radiation in the band 225-275 nm and, therefore, B₂O₃ glasses are particularly adapted to receive refractive index modulation, e.g., to make reflection gratings. Glasses containing SiO₂ and B₂O₃ are particularly suitable when the grating is to be localised in the cladding of a fibre. Glasses containing SiO₂, GeO₂ and B₂O₃ are suitable when the grating is in the path region of a waveguide, e.g., in the core of a fibre.

ABSTRACT

5 It has been demonstrated that B containing glasses are
sensitive to radiation in the band 225-275 nm and,
therefore, B₂O₃ glasses are particularly adapted to
receive refractive index modulation, e.g., to make
reflection gratings. Glasses containing SiO₂ and B₂O₃ are
particularly suitable when the grating is to be
localised in the cladding of a fibre. Glasses
10 containing SiO₂, GeO₂ and B₂O₃ are suitable when the
grating is in the path region of a waveguide, e.g., in
the core of a fibre.

PHOTOINDUCED GRATING IN B₂O₃ CONTAINING GLASS

This invention relates to optical devices which include refractive index modulation, e.g. reflection gratings.

5 Reflection gratings are often implemented as waveguides which have a path region and/or a confining region with a modulated refracted index. The waveguiding structure is often in the form of a fibre. The modulation preferably takes the form of alternate regions of higher and lower refractive index. When radiation traverses the modulation, it is selectively reflected. The period of the refractive index modulation is usually equal to the wavelength to be reflected or to a multiple or sub-multiple of said wavelength. Thus periods in the range 250 to 600 nm preferentially reflect selected wavelengths within the range 800 - 1650 nm.

10 Reflection gratings have many applications in optical signalling. For example, a reflection grating can be associated with a fibre laser in order to narrow the lasing bandwidth. When the refractive index bands are not perpendicular to the fibre axis, the grating can be used for the selective removal of unwanted wavelengths. In addition to reflection gratings, refractive index modulation has other applications, e.g. to achieve phase matching in waveguides, to control spot size and/or shape in waveguides and for storing information.

20 Refractive index modulation is conveniently produced by an optical process in which a photosensitive glass is exposed to radiation which causes an adequate change in its refractive index. The radiation has higher and lower intensities corresponding to the intended pattern of modulation of the refractive index of the glass. In many commonly used embodiments, the mutual interference of two beams of radiation produces the variation of intensity

25
30
35

appropriate for reflection gratings. In the case of information storage, the pattern of radiation relates to the data to be stored.

5 Silica/germania glasses are widely used in optical telecommunications and it has been noticed that these glasses have an optical absorption band extending approximately over the wavelength range 225 - 275 nm and exposure to radiation within this band increases the refractive index of the silica/germania composition. The peak of the band occurs at a wavelength which is close to 240 nm. It has, therefore, been proposed to produce refractive index modulation, e. g. to make reflection gratings, by exposing silica/germania glass compositions to radiation within the wavelength band 225 - 275 nm. Radiation close to 240 nm is particularly suitable. High powers of radiation, e. g. above 1mW continuous, are needed to produce adequate changes in the refractive index and writing times of a few minutes to a few hours are appropriate.

15 WO86/01303 describes the writing of phase gratings in optical fibres or waveguides by the application of intense beams of ultraviolet light. It is stated that the grating is produced in the core of a wave guide and that the core is preferably a germanium-doped silica or glass filament.

20 The sensitivity of the glass is important, and this invention is based upon the unexpected discovery that glasses which contain B_2O_3 are particularly sensitive to radiation, e. g. radiation close to 240nm, and that these glasses are well adapted to carry the necessary refractive index modulation. Preferably the glass contains at least one of SiO_2 and GeO_2 as well as the B_2O_3 .

35 Compositions consisting essentially of GeO_2 and B_2O_3 , preferably containing at least 2 mole % of each component, are suitable for thin film optical devices which are

-2a-

capable of storing data in the form of refractive index modulation.

Compositions consisting essentially of SiO_2 and B_2O_3 , preferably containing at least 2 mole % of each component,

are particularly suitable for carrying the refractive index modulation wherein said modulation constitutes a reflection waveguide located in the confining region of an optical waveguide. Glass consisting essentially of SiO_2 and GeO_2 would be particularly suitable for use as the path region of said waveguide.

Compositions (herein after called ternary compositions) consisting essentially of SiO_2 , GeO_2 and B_2O_3 are particularly suitable for use in optical devices according to the invention. Preferred ternary compositions contain: -

2-40 mole % of B_2O_3 ,
2-40 mole % of GeO_2 , and
at least 30 Mole % of SiO_2 .

It should be noted that B_2O_3 tends to decrease the refractive index of a silica glass whereas GeO_2 tends to increase the refractive index of a silica glass.

Since the concentration of B_2O_3 affects the refractive index as stated above, the refractive index will display a maxima at minima B_2O_3 concentration and the refractive index will display a minima at maximum B_2O_3 concentration. It is standard practice in the preparation of optical waveguides to vary the concentration of a dopant radially through the core region, eg to fabricate a graded index multimode fibre. However, it is less convenient (and even impractical) to produce fine detail longitudinal variation, eg a reflection grating, by varying the concentrations of relevant components.

It has been noticed that some glasses are photo-sensitive whereby exposure to suitable light causes changes in the refractive index and exposure to fine patterns is adapted to produce the desired fine detail. It is doubtful that the optical exposure changes the chemical composition of the glass and it is more appropriate to postulate that structural changes, possibly including defect centres, play

a substantial role in the overall effect. Even though the mechanism is not fully understood, the production of refractive index patterns by exposure to radiation has been demonstrated experimentally.

5

10

15

It has already been stated that glasses which contain B_2O_3 are particularly sensitive to radiation and, as indicated above, the refractive index patterns produced in accordance with the invention are independent of the boron content of the glass. Conveniently the mole ratios B:Si and B:Ge are constant in the region where the refractive index modulation is applied. In most applications it is appropriate for both ratios to be constant, eg. the glass has a uniform composition. (Where one of the elements silicon or germanium is absent it is convenient to take the relevant ratio as 1:0.)

20

25

30

Ternary compositions as defined above have great potential for adjusting the important properties of the glass as required. The refractive index is one of the important properties because it is usually of major importance to match the refractive indices of the device according to the invention to the refractive index of adjacent optical components. The device according to the invention is often required to perform a waveguiding function and proper adjustment of the refractive indices of the confining region and the path region are necessary to get good waveguiding properties. In particular it is important to adjust the refractive index difference between the path region and the confining region to a predetermined value. This difference is usually called Δn .

35

It is possible to adjust the ratio of B_2O_3 : GeO_2 so that the decrease in refractive index caused by the B_2O_3 is balanced (approximately or exactly) by the increase caused by the GeO_2 . Thus the ternary compositions with B_2O_3 in excess of the amount needed to balance the GeO_2 will have refractive

indices lower than that of pure silica whereas ternary compositions with an excess of GeO_2 will have refractive indices greater than that of pure silica. The ternary compositions can be used in either the confining region, or the path region or in both.

The terms "confining region" and "path region" are used to designate the regions of lower and higher refractive index respectively. It will be appreciated that, especially in the case of single mode waveguides, substantial portions of energy will be transferred in that part of the confining region which is close to the path region. Thus the energy in the confining region will interact with a reflection grating located in the confining region whereby gratings in the confining region can be used either alone or to enhance the effect of gratings in the path region.

It will be appreciated that the waveguiding structures mentioned above maybe either planar waveguiding structures or fibres, especially single mode fibres. In the case of a fibre the confining region corresponds to the cladding and the path region corresponds to the core.

In addition to the essential ingredients as specified above the glasses used to make optical devices according to the invention may contain conventional additives, e.g. melting point depressants to facilitate processing during the manufacture of the articles. Melting point depressants for silica glasses include phosphorus, usually present as an oxide, and fluorine.

The preparation of optical devices according to the invention usually includes the preparation of the glasses by the oxidation of the appropriate chlorides using O_2 at high temperature as the oxidizing agent. If desired, the glass intended to carry the refracted index modulation may be subjected to mild reduction, e.g. by heating in the

absence of oxygen. This is conveniently achieved by heating the glass in the presence of helium.

5 The refractive index modulation is applied to the glass which contains B_2O_3 by exposing said glass to the appropriate pattern of radiation which accesses the absorption band having a peak close to 240nm. Radiation having wavelengths within the band 225 - 275 nm, e. g. a wavelength which is close to 240nm, is particularly
10 suitable. Radiation which has double these wavelengths is also effective.

Two reflection gratings according to the invention will now be described by way of example. The gratings are located
15 in the core of a fibre based on silica glasses and the preparation of the fibre will be described first. The exposure of the fibre to radiation in order to produce the refractive index modulation will also be described with reference to accompanying drawing.
20

The fibre was prepared by a modification of the well-known inside deposition process for making optical fibre. In this process, the appropriate number of layers are deposited on the inner surface of a tube which serves as a
25 substrate. Thus the outermost layers are deposited first and the innermost layers are deposited last. After all the layers have been deposited, the tube is collapsed into a solid rod, and the solid rod is drawn into fibre.

30 Individual layers are produced by passing a mixture of oxygen and $SiCl_4$ with reagents such as B_2Cl_4 and $GeCl_4$ through the tube and heating a small section thereof to temperatures in the range 1200°C - 2000°C. Under these conditions the chlorides are converted into the
35 corresponding oxides which initially deposit on the wall of the tube in the form of a fine "soot" which is immediately fused to give a consolidated glass.

As an alternative the deposition is carried out at a temperature such that the deposit remains in a porous state and, at a later stage in the process, the "soot" is fused at a higher temperature to give the consolidated glass. This alternative is appropriate when it is desired to submit the deposit to chemical treatments wherein the porous state facilitates the desired reaction, e.g. reduction. Melting point depressants such as phosphorus and fluorine may be incorporated in the mixture to facilitate processing by causing fusing at lower temperatures.

The heating is carried out by causing a flame to traverse along the length of the tube. The flame heats a short section of the tube so that a portion, about 20 mm long, is heated to the working temperature. This technique of heating is used for all stages of the process, i. e. for the deposition, for consolidating porous layers to solid layers and for the collapse of the tube. Multiple passes are used at all stages of the process.

The starting tube was made of pure silica. It had an external diameter of 18 mm and an internal diameter of 15mm.

Cladding Deposition

The deposited cladding took the form of SiO_2 with phosphorus and fluorine to reduce its melting point. Six layers of cladding were deposited, and the conditions used for the deposition of each layer were as follows: -

Oxygen	2 litres/min
Helium	1.5 litres/min
SiCl ₄	0.45 litres/min
POCl ₃	0.1 litres/min
CCl ₂ F ₂	0.0005 litres/min

5
10
15
In the case of SiCl₄ and POCl₃, the flow rates specify the rate of flow of O₂ through a bubbler thermostated at 24°C. The working temperature was approximately 1525°C. It is emphasised, that after each traverse, each cladding layer was in the form of a clear glassy layer before the next layer was deposited.

20
The cladding layers could be considered to be part of the substrate tube upon which the core layers were deposited. The deposition of cladding layers as described above could be omitted. The main purpose of the cladding layers is to reduce the risk of contamination from the original tube affecting core layers.

25 Core Deposition

Core was deposited in two layers and the conditions for the deposition of each of the two layers were as follows:

30

Oxygen	2.0 litres/min
BCl ₃	0.03 litres/min
SiCl ₄	0.1 litres/min
GeCl ₄	0.2 litres/min

In the case of SiCl₄ and the GeCl₄ the flow rates specify the rate of flow of O₂ through a bubbler thermostated at 24°C. In the case of BCl₃ the flow rate is that of the vapour itself at 300C and 1 atmosphere.

The working temperature was only 1450°C but this consolidated the core layers.

After the preparation described above, the tube was collapsed into a solid rod in the conventional manner using five traverses of the flame.

The solid rod, ie the preform for fibre, had a core which contained approximately 57 mole % SiO₂, 25 mole % B₂O₃ and 18 mole % GeO₂ giving an RI of 1.462. The cladding, essentially SiO₂, had an RI of 1.458 so that $\Delta n = 0.004$. The composition of the glass in the core was substantially uniform, ie. the mole ratio B:Si was 1:2.28 throughout and the mole ratio B:Ge was 1:0.72 throughout.

The procedure described above, apart from the use of BCl₃ in the core, constitutes an essentially conventional preparation of a fibre preform.

The preform prepared as described above was drawn into fibre of 120µm diameter at a temperature of 2,000°C. The fibre was produced at a rate of 18 metres/min. This fibre is the precursor of reflection gratings according to the invention.

Figure 1 illustrates apparatus for producing reflection gratings in optical fibre. Short lengths of the fibre described above were converted into reflection gratings using the technique illustrated in the drawing. In each short length of fibre the core had a uniform composition, ie. as specified for its preform. Before exposure as described below the refractive index of the core was uniform.

A short portion 14 of the fibre 15 was illuminated by a source 10. This radiation was, in the first instance, produced by an Ar⁺ laser, frequency doubled to give output at a wavelength of 244 nm. The beam from the source 10 was directed onto a splitter 11 so that two beams were directed onto mirrors 12 and 13. The mirrors 12 and 13 caused the beams to converge onto the target section, 14. Thus an interference pattern is produced with alternating regions of higher and lower intensity. Because the fibre 15 is photosensitive, the region 14 (whereon the beams are focused) is affected by the beams and the refractive index is increased in the areas of high intensity. Thus a reflection grating is produced in the region 14.

It will be appreciated that the spacing of the interference pattern is affected by the angle at which the two beams intersect one another, and hence the spacing of the grating can be adjusted by adjusting the relative position of the splitter 11 and the mirrors 12 and 13.

Two specimens of this fibre were subjected, to an interference pattern to produce reflection gratings A and B. For comparison, a reflection grating was prepared from a conventional fibre, i.e. without the boron. This comparative grating is identified as grating X. Important measurements on these gratings and their fibre waveguides are given in the following table.

	GRATING A	GRATING B	GRATING X
Length	2mm	1mm	2mm
RI Core	1.462	1.462	1.463
Δn	.004	.004	.005
Index Modulation	1×10^{-3}	7×10^{-4}	3.4×10^{-5}
Grating Reflectivity	99.5%	67%	1.2%
RIC	25%	18%	0.68%
Input Energy	60J	48J	192J

The "RIC" is the relative index change and it is calculated as $[(\text{index modulation})/\Delta n] \times 100$ (to convert to percentage).

(In optical technology, refractive index matching of components is often important to avoid unwanted reflections from component interfaces. Thus reflection gratings need to be refractive index-matched to adjacent components and this limits the freedom to adjust the composition to maximise the photo sensitivity and the grating properties. It is usually easier to obtain index modulation in fibre which has high Δn and the RIC takes this circumstance into account).

The properties of grating X can be compared directly with grating A because both gratings are 2mm long. The most important property of the grating is reflectivity and in this key parameter grating A is very much better than grating X (99.5% as against 1.2%). It will be appreciated that the length of a grating has a strong effect upon its reflectivity and the longer a grating (other things being

equal) the better its reflectivity. It is, therefore, important that both grating A and X have the same length.

5 Grating B has only half the length but its reflectivity is still 67% which is considerably better than grating X even though grating X is longer. The index modulations of gratings A and B are similar (10×10^{-4} as compared with 7×10^{-4}). Grating X has a much lower modulation (0.34×10^{-4}) which is a clear indication that the boron, containing
10 the glasses are more photo sensitive. Grating X has a slightly higher Δn (0.005 against 0.004) so the RIC values emphasise the superiority of the gratings according to the invention.

The embodiments of the invention in which an exclusive property or privilege is claimed are defined as follows:

1. A photosensitive optical fibre having a photosensitive core and a cladding, said cladding consisting of a first silica glass and said core consisting of a second silica glass having a refractive index substantially 0.004 higher than said first silica glass wherein said second silica glass contains:
 - a) at least 30 mole% of SiO_2
 - b) 2 - 40 mole% of GeO_2
 - c) 2 - 40 mole% of B_2O_3 .
2. A photosensitive optical fibre according to claim 1, wherein the second silica glass composition is a ternary composition.
3. A photosensitive optical fibre according to claim 2, wherein the second silica glass consists of substantially:
 - a) 57 mole% of SiO_2
 - b) 18 mole% of GeO_2
 - c) 25 mole% of B_2O_3 .
4. A photosensitive optical fibre according to claim 1, wherein the first silica glass composition consists essentially of SiO_2 .
5. A photosensitive optical fibre according to claim 4, wherein the first silica glass composition contains combined P and/or F to reduce its melting point.

6. A photosensitive optical fibre according to claim 1, wherein the first silica glass composition consists essentially of SiO_2 and B_2O_3 whereby the first silica glass composition is photosensitive.
7. A photosensitive optical fibre according to claim 1 wherein said cladding consists essentially of 2 - 98 mole% SiO_2 and 2 - 98 mole% B_2O_3 .

Morganb/416304.1

Fig. 1.

