

J. J. DOMINIC.

Shaft Clamp.

No. 110,961.

Patented Jan. 17, 1871.

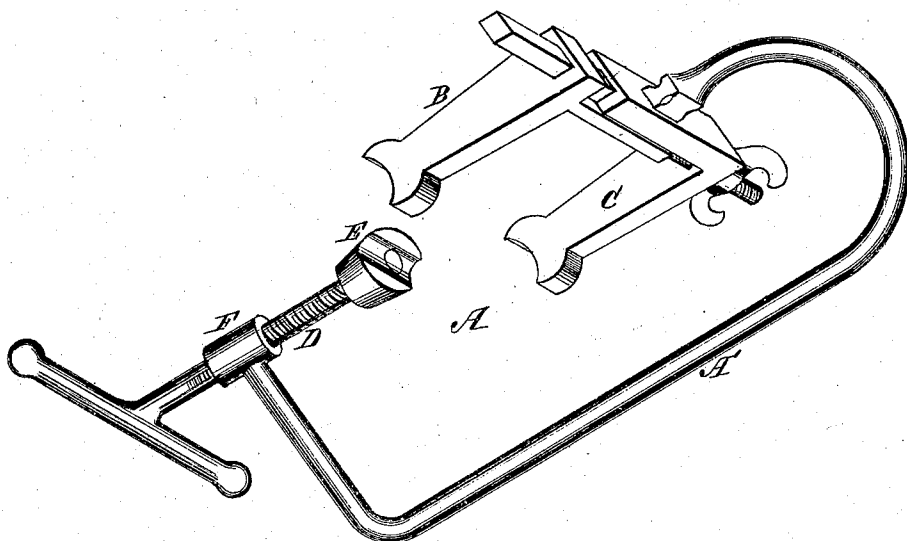

*Witnesses:*

*E. Wolf*  
*L. J. Mabee*

*Inventor:*

*J. J. Dominic*  
*per Munn & Co.*  
*Attorneys.*

# United States Patent Office.

JOHN J. DOMINIC, OF GALLUPVILLE, NEW YORK.

Letters Patent No. 110,961, dated January 17, 1871.

## IMPROVEMENT IN CLAMPS.

The Schedule referred to in these Letters Patent and making part of the same.

### *To all whom it may concern:*

Be it known that I, JOHN J. DOMINIC, of Gallupville, in the county of Schoharie and State of New York, have invented a new and useful Improvement in Clamp for Anti-rattling Shaft-Connections; and I do hereby declare that the following is a full, clear, and exact description thereof, which will enable others skilled in the art to make and use the same, reference being had to the accompanying drawing forming part of this specification.

The invention, hereinafter described, consists of a clamp adapted by its peculiar construction and combination of parts to the application of rubber in a compressed state to thill-couplings.

The accompanying drawing is a perspective view of my improved clamp.

Similar letters of reference indicate corresponding parts.

In using the "anti-rattling" thill-connection it is found extremely difficult to attach the thills or shafts, or to get the bolts in place, as the rubber which is placed in the connection or shackle to prevent rattling has to be compressed very much, and some appliance has long been required to facilitate this difficult operation. By means of my clamp it is very easily performed.

A is the clamp.

A' is the back or stock, to which the jaws are attached, and which supports the tightening-screw.

B and C are the jaws, one of which may be made

adjustable by means of a shank and socket and thumb-screw, so as to adjust them to different-sized shafts.

D is the clamp-screw.

E is the swivel on the end of the screw.

The screw works through the end, F, of the stock, as in a screw-nut.

In applying the clamp the swivel is placed against the clip back of the axle, and the jaws project forward and take hold of the ears on the sides of the eye of the shaft. When thus adjusted the screw D is turned and the shaft is brought up to and into the shackle and held while the bolt is inserted. The same operation is, of course, performed for each thill or shaft.

By this simple contrivance the rubber is compressed and the shafts attached with perfect ease, and its advantages will be duly appreciated by all who have been annoyed in attaching them in the ordinary manner.

Having thus described my invention,

I claim as new and desire to secure by Letters Patent—

The adjustable jaws B C, screw D, swivel E, and stock A' F, all combined as described, to form a tool for applying rubber to a thill-coupling for the prevention of rattling.

JOHN J. DOMINIC.

Witnesses:

DANIEL C. BAKER,  
LYMAN BAKER.