

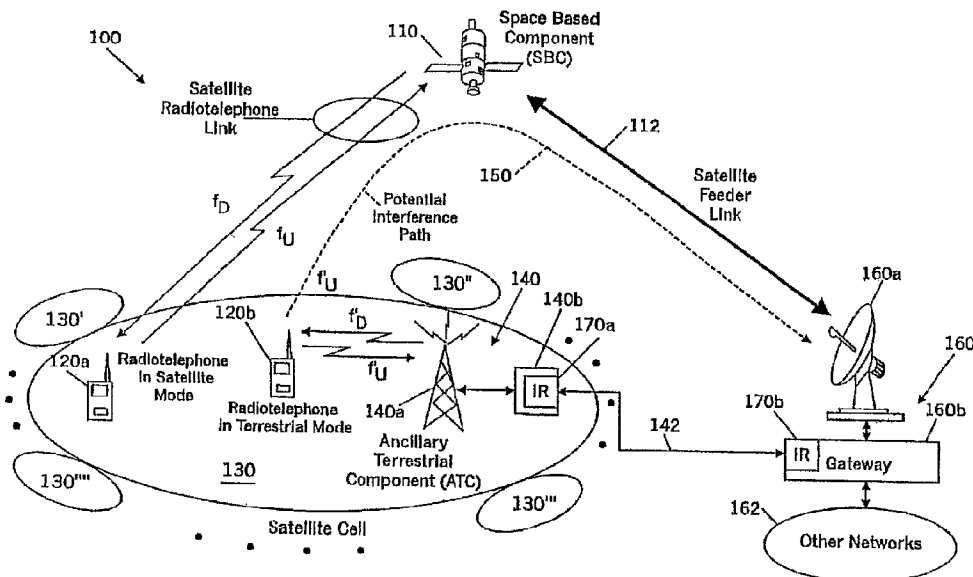

(22) Date de dépôt/Filing Date: 2004/04/14  
 (41) Mise à la disp. pub./Open to Public Insp.: 2004/11/18  
 (45) Date de délivrance/Issue Date: 2020/12/15  
 (62) Demande originale/Original Application: 2 515 209  
 (30) Priorité/Priority: 2003/05/01 (US60/467100)

(51) Cl.Int./Int.Cl. *H04W 52/24* (2009.01),  
*H04W 28/26* (2009.01)  
 (72) Inventeur/Inventor:  
KARABINIS, PETER D., US  
 (73) Propriétaire/Owner:  
ATC TECHNOLOGIES, LLC, US  
 (74) Agent: MARKS & CLERK

(54) Titre : COMMANDE DE LA PUISSANCE DE RAYONNEMENT TOTALE POUR SYSTEMES ET PROCEDES DE COMMUNICATION PAR TELEPHONE CELLULAIRE SATELLITE MULTIBANDE/MULTIMODE  
 (54) Title: AGGREGATE RADIATED POWER CONTROL FOR MULTI-BAND/MULTI-MODE SATELLITE RADIOTELEPHONE COMMUNICATIONS SYSTEMS AND METHODS



(57) **Abrégé/Abstract:**

A satellite radiotelephone system includes a space-based component that is configured to communicate with multiple radiotelephones over multiple frequency bands and/or multiple air interfaces. An ancillary terrestrial network is configured to communicate terrestrially with the multiple radiotelephones over substantially the multiple frequency bands and/or substantially the multiple air interfaces. An aggregate radiated power controller is configured to limit an aggregate radiated power by the multiple radiotelephones to a maximum aggregate radiated power.

## **ABSTRACT**

A satellite radiotelephone system includes a space-based component that is configured to communicate with multiple radiotelephones over multiple frequency bands and/or multiple air interfaces. An ancillary terrestrial network is configured to communicate terrestrially with the multiple radiotelephones over substantially the multiple frequency bands and/or substantially the multiple air interfaces. An aggregate radiated power controller is configured to limit an aggregate radiated power by the multiple radiotelephones to a maximum aggregate radiated power.

**AGGREGATE RADIATED POWER CONTROL FOR MULTI-BAND/MULTI-MODE SATELLITE RADIOTELEPHONE COMMUNICATIONS SYSTEMS AND METHODS**

5

**Field of the Invention**

This invention relates to radiotelephone communications systems and methods, and more particularly to terrestrial cellular and satellite cellular radiotelephone communications systems and methods.

10

**Background of the Invention**

Satellite radiotelephone communications systems and methods are widely used for radiotelephone communications. Satellite radiotelephone communications systems and methods generally employ at least one space-based component, such as one or more satellites that are configured to wirelessly communicate with a plurality of satellite radiotelephones.

15

A satellite radiotelephone communications system or method may utilize a single antenna beam covering an entire area served by the system. Alternatively, in cellular satellite radiotelephone communications systems and methods, multiple beams are provided, each of which can serve distinct geographical areas in the overall service region, to collectively serve an overall satellite footprint. Thus, a cellular architecture similar to that used in conventional terrestrial cellular radiotelephone systems and methods can be implemented in cellular satellite-based systems and methods. The satellite typically communicates with radiotelephones over a bidirectional communications pathway, with radiotelephone communication signals being communicated from the satellite to the radiotelephone over a

20

downlink or forward link, and from the radiotelephone to the satellite over an uplink or return link.

The overall design and operation of cellular satellite radiotelephone systems and methods are well known to those having skill in the art, and need not be described further herein. Moreover, as used herein, the term "radiotelephone" includes cellular and/or satellite radiotelephones with or without a multi-line display; Personal Communications System (PCS) terminals that may combine a radiotelephone with data processing, facsimile and/or data communications capabilities; Personal Digital Assistants (PDA) that can include a radio frequency transceiver and a pager, Internet/intranet access, Web browser, organizer, calendar and/or a global positioning system (GPS) receiver; and/or conventional laptop and/or palmtop computers or other appliances, which include a radio frequency transceiver. A radiotelephone also may be referred to herein as a radioterminal.

Terrestrial networks can enhance cellular satellite radiotelephone system availability, efficiency and/or economic viability by terrestrially reusing at least some of the frequency bands that are allocated to cellular satellite radiotelephone systems. In particular, it is known that it may be difficult for cellular satellite radiotelephone systems to reliably serve densely populated areas, because the satellite signal may be blocked by high-rise structures and/or may not penetrate into buildings. As a result, the satellite spectrum may be underutilized or unutilized in such areas. The terrestrial reuse of at least some of a satellite band's frequencies can reduce or eliminate this potential problem.

Moreover, the capacity of the overall system can be increased significantly by the introduction of terrestrial reuse of a satellite band's frequencies, since terrestrial frequency reuse can be much denser than that of a satellite-only system. In fact, capacity can be enhanced where it may be mostly needed, i.e., densely populated urban/industrial/commercial areas. As a result, the overall system can become much more economically viable, as it may be able to serve a much larger subscriber base.

One example of terrestrial reuse of satellite frequencies is described in U. S. Patent 5,937, 332 to the present inventor Karabinis entitled Satellite Telecommunications Repeaters and Retransmission Methods. As described therein, satellite telecommunications repeaters are provided which receive, amplify, and locally retransmit the downlink signal received from a satellite thereby increasing the effective downlink margin in the vicinity of the satellite telecommunications repeaters and allowing an increase in the penetration of uplink and downlink signals into buildings, foliage, transportation vehicles,

and other objects which can reduce link margin. Both portable and non-portable repeaters are provided. See the abstract of U.S. Patent 5,937,332.

Finally, satellite radiotelephones for a satellite radiotelephone system or method having a terrestrial component within the same satellite frequency band and using  
5 substantially the same air interface for both terrestrial and satellite communications can be cost effective and/or aesthetically appealing. Conventional dual band/dual mode alternatives, such as the well known Thuraya, Iridium and/or Globalstar dual mode satellite/terrestrial radiotelephone systems, may duplicate some components, which may lead to increased cost, size and/or weight of the radiotelephone. See U.S. Patent 6,052,560 to the present inventor  
10 Karabinis, entitled *Satellite System Utilizing a Plurality of Air Interface Standards and Method Employing Same*.

In view of the above discussion, there continues to be a need for systems and methods for terrestrial reuse of cellular satellite frequencies that can allow improved reliability, capacity, cost effectiveness and/or aesthetic appeal for cellular satellite radiotelephone  
15 systems, methods and/or satellite radiotelephones.

#### **Summary of the Invention**

Some embodiments of the present invention provide satellite radiotelephone systems and communications methods wherein a space-based component is configured to  
20 communicate with radiotelephones in a satellite footprint that is divided into a plurality of satellite cells. The space-based component is configured to communicate with a first radiotelephone in a first satellite cell over a first frequency band and/or a first air interface, and to communicate with a second radiotelephone in a second satellite cell over a second frequency band and/or a second air interface. In some embodiments, an ancillary terrestrial  
25 network also is provided that is configured to communicate terrestrially with the first radiotelephone over substantially the first frequency band and/or substantially the first air interface, and to communicate terrestrially with the second radiotelephone over substantially the second frequency band and/or substantially the second air interface.

In other embodiments, satellite radiotelephone systems and methods comprise a  
30 space-based component that is configured to communicate with a first radiotelephone over a first frequency band and/or a first air interface, and with a second radiotelephone over a second frequency band and/or a second air interface. An ancillary terrestrial network is configured to communicate terrestrially with the first radiotelephone over substantially the first frequency band and/or substantially the first air interface, and to communicate

terrestrially with the second radiotelephone over substantially the second frequency band and/or substantially the second air interface. The first and second radiotelephones may be in the same satellite cell or in different satellite cells.

In any of the above embodiments, the ancillary terrestrial network can comprise a first  
5 ancillary terrestrial component that is configured to communicate terrestrially with the first radiotelephone over substantially the first frequency band and/or substantially the first air interface, and a second ancillary terrestrial component that is configured to communicate terrestrially with the second and/or first radiotelephone over substantially the second  
10 frequency band and/or substantially the second air interface. In some embodiments, the first ancillary terrestrial component is in the first satellite cell, and the second ancillary terrestrial component is in the second satellite cell. In other embodiments, they are in the same satellite cell. In yet other embodiments, the first ancillary terrestrial component is operated by a first wireless network operator and the second ancillary terrestrial component is operated by a second wireless network operator.

15 Moreover, in any of the above-described embodiments, the ancillary terrestrial network can comprise a first portion that is configured to communicate terrestrially with the first radiotelephone over substantially the first frequency band and/or substantially the first air interface, and a second portion that is configured to communicate terrestrially with the second and/or first radiotelephone over substantially the second frequency band and/or  
20 substantially the second air interface. In some embodiments, the first portion is operated by a first wireless network operator and the second portion is operated by a second wireless network operator.

In any of the above embodiments, a gateway also may be provided that is configured to communicate with the space-based component over a feeder link. The feeder link is  
25 configured to transport communications between the space-based component and the first and second radiotelephones. In some embodiments, the feeder link comprises the first air interface and the second air interface.

Still other embodiments of the present invention control the aggregate radiated power by the radiotelephones in multi-band/multi-mode satellite radiotelephone communications  
30 systems and methods. Specifically, some embodiments of the present invention provide satellite radiotelephone systems wherein a space-based component is configured to communicate with a plurality of radiotelephones over a plurality of frequency bands and/or a plurality of air interfaces. An ancillary terrestrial network is configured to communicate terrestrially with the plurality of radiotelephones over substantially the plurality of first

frequency bands and/or substantially the plurality of air interfaces. An aggregate radiated power controller is configured to limit an aggregate radiated power by the plurality of radiotelephones to a maximum aggregate radiated power. Analogous aggregate radiated power controlling methods also may be provided.

5           Accordingly, some embodiments of the present invention allow space-based communications to be added to a first terrestrial network that is configured to communicate with a first radiotelephone over a first frequency band and/or a first air interface, and to a second terrestrial network that is configured to communicate with a second radiotelephone over a second frequency band and/or a second air interface. These embodiments provide  
10       communications between a space-based component and the first radiotelephone over substantially the first frequency band and/or the first air interface and between the space-based component and the second radiotelephone over substantially the second frequency band and/or substantially the second air interface. It will be understood that embodiments of the present invention may be provided as systems and/or methods.

15           According to an aspect, there is provided a satellite radiotelephone system comprising: a space-based component that is configured to communicate with a plurality of radiotelephones over a plurality of frequency bands and/or a plurality of air interfaces; an ancillary terrestrial network that is configured to communicate terrestrially with the plurality of radiotelephones over substantially the plurality of frequency bands and/or substantially the  
20       plurality of air interfaces; and an aggregate radiated power controller that is configured to control the plurality of radiotelephones and/or the ancillary terrestrial network so as to limit an aggregate radiated power by the plurality of radiotelephones to a maximum aggregate radiated power; wherein the plurality of frequency bands and/or the plurality of air interfaces comprise a GSM air interface and a CDMA air interface and wherein the aggregate radiated  
25       power controller is configured to control the plurality of radiotelephones and/or the ancillary terrestrial network, so as to limit the aggregate radiated power by the plurality of radiotelephones to a maximum aggregate radiated power substantially according to the following:  $N_{\text{GSM}} + 13,800N_{\text{CDMA}}/107,894 = 13,800$ ; where  $N_{\text{GSM}}$  denotes a number of co-frequency time slots that are using the GSM air interface and  $N_{\text{CDMA}}$  denotes a number of co-  
30       frequency codes that are using the CDMA air interface.

          According to another aspect, there is provided a satellite radiotelephone system comprising: a space-based component that is configured to communicate with a plurality of radiotelephones over a plurality of frequency bands and/or a plurality of air interfaces; an

ancillary terrestrial network that is configured to communicate terrestrially with the plurality of radiotelephones over substantially the plurality of frequency bands and/or substantially the plurality of air interfaces; and an aggregate radiated power controller that is configured to control the plurality of radiotelephones and/or the ancillary terrestrial network so as to limit an aggregate radiated power by the plurality of radiotelephones to a maximum aggregate radiated power; wherein the plurality of frequency bands and/or the plurality of air interfaces comprise a GSM air interface, a cdma2000 air interface and/or a W-CDMA air interface and wherein the aggregate radiated power controller is configured to control the plurality of radiotelephones and/or the ancillary terrestrial network, so as to limit the aggregate radiated power by the plurality of radiotelephones to a maximum aggregate radiated power substantially according to the following:  $N/8+M/50+L/200=R$ ; where N denotes a number of co-frequency time slots that are using the GSM air interface, M denotes a number of co-frequency codes that are using the cdma2000 air interface, L denotes a number of co-frequency codes that are using the W-CDMA air interface and R denotes an authorized GSM-based frequency reuse.

According to another aspect, there is provided a satellite radiotelephone system comprising: a space-based component that is configured to communicate with a plurality of radiotelephones over a plurality of frequency bands and/or a plurality of air interfaces; an ancillary terrestrial network that is configured to communicate terrestrially with the plurality of radiotelephones over substantially the plurality of frequency bands and/or substantially the plurality of air interfaces; and an aggregate radiated power controller that is configured to control the plurality of radiotelephones and/or the ancillary terrestrial network so as to limit an aggregate radiated power by the plurality of radiotelephones to a maximum aggregate radiated power; wherein the aggregate radiated power controller is configured to control the plurality of radiotelephones and/or the ancillary terrestrial network, so as to limit the aggregate radiated power by the plurality of radiotelephones to a maximum aggregate radiated power according to the following:

$$\sum_{i=1}^x \frac{N_i}{F_i} = \text{MARP};$$

where  $N_i$  denotes a number of co-frequency channels that are using a given frequency band and/or air interface  $i$ ,  $F_i$  denotes a corresponding equivalence factor, which may be less than,

greater than or equal to 1, for the given frequency band/air interface  $i$ , and MARP is a measure of the maximum aggregate radiated power.

According to another aspect of the present invention, there is provided a satellite radiotelephone system comprising: a space-based component that is configured to communicate with a plurality of radiotelephones over a plurality of frequency bands and/or a plurality of air interfaces; an ancillary terrestrial network that is configured to communicate terrestrially with the plurality of radiotelephones over substantially the plurality of frequency bands and/or substantially the plurality of air interfaces; and an aggregate radiated power controller that is configured to control the plurality of radiotelephones and/or the ancillary terrestrial network so as to limit an aggregate radiated power by the plurality of radiotelephones to a maximum aggregate radiated power; wherein the aggregate radiated power controller is configured to control the plurality of radiotelephones and/or the ancillary terrestrial network, so as to limit the aggregate radiated power by the plurality of radiotelephones to a maximum aggregate radiated power according to the following:

$$\sum_{i=1}^x \frac{N_i}{F_i} = \text{MARP};$$

where  $N_i$  denotes a number of co-frequency channels that are using a given structural attenuation margin  $i$  for a given frequency band and/or air interface,  $F_i$  denotes a corresponding equivalence factor, which may be less than, greater than or equal to 1, for the given structural attenuation margin  $i$  for the given frequency band/air interface, and MARP is a measure of the maximum aggregate radiated power.

According to another aspect, there is provided a satellite radiotelephone system comprising: a space-based component that is configured to communicate with a plurality of radiotelephones over a plurality of frequency bands and/or a plurality of air interfaces; an ancillary terrestrial network that is configured to communicate terrestrially with the plurality of radiotelephones over substantially the plurality of frequency bands and/or substantially the plurality of air interfaces; and an aggregate radiated power controller that is configured to control the plurality of radiotelephones and/or the ancillary terrestrial network so as to limit an aggregate radiated power by the plurality of radiotelephones to a maximum aggregate radiated power; wherein the aggregate radiated power controller is configured to control the plurality of radiotelephones and/or the ancillary terrestrial network, so as to limit the aggregate radiated power by a plurality of co-frequency radiotelephones to a maximum

aggregate radiated power according to the following:

$$\sum_{i=1}^x (\text{psd})_i = \text{MARF} ;$$

where  $(\text{psd})_i$  denotes a measure of radiated power spectral density from an  $i^{\text{th}}$  radiotelephone at a satellite and MARF is a measure of the allowed maximum aggregate radiated power.

5 According to another aspect, there is provided a satellite radiotelephone communications method comprising: communicating between a space-based component and a plurality of radiotelephones over a plurality of frequency bands and/or a plurality of air interfaces; communicating terrestrially with the plurality of radiotelephones over substantially the plurality of frequency bands and/or substantially the plurality of air  
10 interfaces; and controlling the plurality of radiotelephones and/or the ancillary terrestrial network so as to limit an aggregate radiated power by the plurality of radiotelephones to a maximum aggregate radiated power; wherein the plurality of frequency bands and/or the plurality of air interfaces comprise a GSM air interface and a CDMA air interface and wherein controlling the plurality of radiotelephones and/or the ancillary terrestrial network so  
15 as to limit the aggregate radiated power by the plurality of radiotelephones to a maximum aggregate radiated power comprises controlling the plurality of radiotelephones substantially according to the following:  $N_{\text{GSM}} + 13,800 N_{\text{CDMA}} / 107,894 = 13,800$ ; where  $N_{\text{GSM}}$  denotes a number of co-frequency time slots that are using the GSM air interface and  $N_{\text{CDMA}}$  denotes a number of co-frequency codes that are using the CDMA air interface.

20 According to another aspect, there is provided a satellite radiotelephone communications method comprising: communicating between a space-based component and a plurality of radiotelephones over a plurality of frequency bands and/or a plurality of air interfaces; communicating terrestrially with the plurality of radiotelephones over substantially the plurality of frequency bands and/or substantially the plurality of air  
25 interfaces; and controlling the plurality of radiotelephones and/or the ancillary terrestrial network so as to limit an aggregate radiated power by the plurality of radiotelephones to a maximum aggregate radiated power; wherein the plurality of frequency bands and/or a plurality of air interfaces comprise a GSM air interface, a cdma2000 air interface and/or a W-CDMA air interface and wherein controlling the plurality of radiotelephones and/or the  
30 ancillary terrestrial network, so as to limit the aggregate radiated power by the plurality of radiotelephones to a maximum aggregate radiated power comprises controlling the plurality of radiotelephones substantially according to the following:  $N/80 + M/50 + L/200 + R$ ; where N

denotes a number of co-frequency time slots that are using the GSM air interface, M denotes a number of co-frequency codes that are using the cdma2000 air interface, L denotes a number of co-frequency codes that are using the W-CDMA air interface, and R denotes an authorized GSM-based frequency reuse.

5           According to another aspect, there is provided a satellite radiotelephone communications method comprising: communicating between a space-based component and a plurality of radiotelephones over a plurality of frequency bands and/or a plurality of air interfaces; communicating terrestrially with the plurality of radiotelephones over substantially the plurality of frequency bands and/or substantially the plurality of air  
10 interfaces; and controlling the plurality of radiotelephones and/or the ancillary terrestrial network so as to limit an aggregate radiated power by the plurality of radiotelephones to a maximum aggregate radiated power; wherein controlling the plurality of radiotelephones and/or the ancillary terrestrial network, so as to limit the aggregate radiated power by the plurality of radiotelephones to a maximum aggregate radiated power is performed according  
15 to the following:

$$\sum_{i=1}^x \frac{N_i}{F_i} = \text{MARP};$$

where  $N_i$  denotes a number of co-frequency channels that are using a given frequency band and/or air interface  $i$ ,  $F_i$  denotes a corresponding equivalence factor, which may be less than, greater than or equal to 1, for the given frequency band/air interface  $i$ , and MARP is a  
20 measure of the maximum aggregate radiated power.

          According to another aspect, there is provided a satellite radiotelephone communications method comprising: communicating between a space-based component and a plurality of radiotelephones over a plurality of frequency bands and/or a plurality of air  
25 interfaces; communicating terrestrially with the plurality of radiotelephones over substantially the plurality of frequency bands and/or substantially the plurality of air interfaces; and controlling the plurality of radiotelephones and/or the ancillary terrestrial network so as to limit an aggregate radiated power by the plurality of radiotelephones to a maximum aggregate radiated power; wherein controlling the plurality of radiotelephones and/or the ancillary terrestrial network so as to limit the aggregate radiated power by the  
30 plurality of radiotelephones to a maximum aggregate radiated power is performed according to the following:

$$\sum_{i=1}^x \frac{N_i}{F_i} = \text{MARP};$$

where  $N_i$  denotes a number of co-frequency channels that are using a given structural attenuation margin  $i$  for a given frequency band and/or air interface,  $F_i$  denotes a corresponding equivalence factor, which may be less than, greater than or equal to 1, for the given structural attenuation margin  $i$  for the given frequency band/air interface, and MARP is a measure of the maximum aggregate radiated power.

According to another aspect, there is provided a satellite radiotelephone communications method comprising: communicating between a space-based component and a plurality of radiotelephones over a plurality of frequency bands and/or a plurality of air interfaces; communicating terrestrially with the plurality of radiotelephones over substantially the plurality of frequency bands and/or substantially the plurality of air interfaces; and controlling the plurality of radiotelephones and/or the ancillary terrestrial network so as to limit an aggregate radiated power by the plurality of radiotelephones to a maximum aggregate radiated power; wherein controlling the plurality of radiotelephones and/or the ancillary terrestrial network, so as to limit the aggregate radiated power by a plurality of co-frequency radiotelephones to a maximum aggregate radiated power is performed according to the following:

$$\sum_{i=1}^x (\text{psd})_i = \text{MARP};$$

where  $(\text{psd})_i$  denotes a measure of radiated power spectral density from an  $i^{\text{th}}$  radiotelephone at a satellite and MARP is a measure of the allowed maximum aggregate radiated power.

According to another aspect, there is provided an apparatus for controlling a satellite radiotelephone system that comprises a space-based component that is configured to communicate with a plurality of radiotelephones over a plurality of frequency bands and/or a plurality of air interfaces and an ancillary terrestrial network that is configured to communicate terrestrially with the plurality of radiotelephones over substantially the plurality of frequency bands and/or substantially the plurality of air interfaces, the apparatus comprising: an aggregate radiated power controller that is configured to control the plurality of radiotelephones and/or the ancillary terrestrial network so as to limit the aggregate radiated power by the plurality of radiotelephones to a maximum aggregate radiated power; wherein the plurality of frequency bands and/or the plurality of air interfaces comprise a GSM air

interface and a CDMA air interface and wherein the aggregate radiated power controller is configured to control the plurality of radiotelephones and/or the ancillary terrestrial network, so as to limit the aggregate radiated power by the plurality of radiotelephones to a maximum aggregate radiated power substantially according to the following:

- 5  $N_{\text{GSM}} + 13,800 N_{\text{CDMA}} / 107,894 = 13,800$ ; where  $N_{\text{GSM}}$  denotes a number of co-frequency time slots that are using the GSM air interface and  $N_{\text{CDMA}}$  denotes a number of co-frequency codes that are using the CDMA air interface.

According to another aspect, there is provided an apparatus for controlling a satellite radiotelephone system that comprises a space-based component that is configured to  
 10 communicate with a plurality of radiotelephones over a plurality of frequency bands and/or a plurality of air interfaces and an ancillary terrestrial network that is configured to communicate terrestrially with the plurality of radiotelephones over substantially the plurality of frequency bands and/or substantially the plurality of air interfaces, the apparatus comprising: an aggregate radiated power controller that is configured to control the plurality  
 15 of radiotelephones and/or the ancillary terrestrial network so as to limit the aggregate radiated power by the plurality of radiotelephones to a maximum aggregate radiated power; wherein the plurality of frequency bands and/or the plurality of air interfaces comprise a GSM air interface, a cdma2000 air interface and/or a W-CDMA air interface and wherein the aggregate radiated power controller is configured to control the plurality of radiotelephones  
 20 and/or the ancillary terrestrial network, so as to limit the aggregate radiated power by the plurality of radiotelephones to a maximum aggregate radiated power substantially according to the following:  $N/8 + M/50 + L/200 = R$ ; where N denotes a number of co-frequency time slots that are using the GSM air interface, M denotes a number of co-frequency codes that are using the cdma2000 air interface, L denotes a number of co-frequency codes that are using  
 25 the W-CDMA air interface, and R denotes an authorized GSM-based frequency reuse.

According to another aspect, there is provided an apparatus for controlling a satellite radiotelephone system that comprises a space-based component that is configured to communicate with a plurality of radiotelephones over a plurality of frequency bands and/or a plurality of air interfaces and an ancillary terrestrial network that is configured to  
 30 communicate terrestrially with the plurality of radiotelephones over substantially the plurality of frequency bands and/or substantially the plurality of air interfaces, the apparatus comprising: an aggregate radiated power controller that is configured to control the plurality of radiotelephones and/or the ancillary terrestrial network so as to limit the aggregate radiated

power by the plurality of radiotelephones to a maximum aggregate radiated power; wherein the aggregate radiated power controller is configured to control the plurality of radiotelephones and/or the ancillary terrestrial network, so as to limit the aggregate radiated power by the plurality of radiotelephones to a maximum aggregate radiated power according to the following:

$$\sum_{i=1}^x \frac{N_i}{F_i} = \text{MARP};$$

where  $N_i$  denotes a number of co-frequency channels that are using a given frequency band and/or air interface  $i$ ,  $F_i$  denotes a corresponding equivalence factor, which may be less than, greater than or equal to 1, for the given frequency band/air interface  $i$ , and MARP is a measure of the maximum aggregate radiated power.

According to another aspect, there is provided an apparatus for controlling a satellite radiotelephone system that comprises a space-based component that is configured to communicate with a plurality of radiotelephones over a plurality of frequency bands and/or a plurality of air interfaces and an ancillary terrestrial network that is configured to communicate terrestrially with the plurality of radiotelephones over substantially the plurality of frequency bands and/or substantially the plurality of air interfaces, the apparatus comprising: an aggregate radiated power controller that is configured to control the plurality of radiotelephones and/or the ancillary terrestrial network so as to limit the aggregate radiated power by the plurality of radiotelephones to a maximum aggregate radiated power; wherein the aggregate radiated power controller is configured to control the plurality of radiotelephones and/or the ancillary terrestrial network so as to limit the aggregate radiated power by the plurality of radiotelephones to a maximum aggregate radiated power according to the following:

$$\sum_{i=1}^x \frac{N_i}{F_i} = \text{MARP};$$

where  $N_i$  denotes a number of co-frequency channels that are using a given structural attenuation margin  $i$  for a given frequency band and/or air interface,  $F_i$  denotes a corresponding equivalence factor, which may be less than, greater than or equal to 1, for the given structural attenuation margin  $i$  for the given frequency band/air interface, and MARP is a measure of the maximum aggregate radiated power.

According to another aspect, there is provided an apparatus for controlling a satellite radiotelephone system that comprises a space-based component that is configured to communicate with a plurality of radiotelephones over a plurality of frequency bands and/or a plurality of air interfaces and an ancillary terrestrial network that is configured to

5 communicate terrestrially with the plurality of radiotelephones over substantially the plurality of frequency bands and/or substantially the plurality of air interfaces, the apparatus comprising: an aggregate radiated power controller that is configured to control the plurality of radiotelephones and/or the ancillary terrestrial network so as to limit the aggregate radiated power by the plurality of radiotelephones to a maximum aggregate radiated power; wherein

10 the aggregate radiated power controller is configured to control the plurality of radiotelephones and/or the ancillary terrestrial network, so as to limit the aggregate radiated power by a plurality of co-frequency radiotelephones to a maximum aggregate radiated power according to the following:

$$\sum_{i=1}^x (\text{psd})_i = \text{MARP};$$

15 where  $(\text{psd})_i$  denotes a measure of radiated power spectral density from an  $i^{\text{th}}$  radiotelephone at a satellite and MARP is a measure of the allowed maximum aggregate radiated power.

According to another aspect, there is provided a method for controlling a satellite radiotelephone system that comprises a space-based component that is configured to communicate with a plurality of radiotelephones over a plurality of frequency bands and/or a

20 plurality of air interfaces and an ancillary terrestrial network that is configured to communicate terrestrially with the plurality of radiotelephones over substantially the plurality of frequency bands and/or substantially the plurality of air interfaces, the method comprising: controlling the plurality of radiotelephones and/or the ancillary terrestrial network so as to limit the aggregate radiated power by the plurality of radiotelephones to a maximum

25 aggregate radiated power; wherein the plurality of frequency bands and/or the plurality of air interfaces comprise a GSM air interface and a CDMA air interface and wherein controlling the plurality of radiotelephones and/or the ancillary terrestrial network, so as to limit the aggregate radiated power by the plurality of radiotelephones to a maximum aggregate radiated power comprises controlling the plurality of radiotelephones substantially according

30 to the following:  $N_{\text{GSM}} + 13,800 N_{\text{CDMA}} / 107,894 = 13,800$ ; where  $N_{\text{GSM}}$  denotes a number of co-frequency time slots that are using the GSM air interface and  $N_{\text{CDMA}}$  denotes a

number of co-frequency codes that are using the CDMA air interface.

According to another aspect, there is provided a method for controlling a satellite radiotelephone system that comprises a space-based component that is configured to communicate with a plurality of radiotelephones over a plurality of frequency bands and/or a plurality of air interfaces and an ancillary terrestrial network that is configured to communicate terrestrially with the plurality of radiotelephones over substantially the plurality of frequency bands and/or substantially the plurality of air interfaces, the method comprising: controlling the plurality of radiotelephones and/or the ancillary terrestrial network so as to limit the aggregate radiated power by the plurality of radiotelephones to a maximum aggregate radiated power; wherein the plurality of frequency bands and/or a plurality of air interfaces comprise a GSM air interface, a cdma2000 air interface and/or a W-CDMA air interface and wherein controlling the plurality of radiotelephones and/or the ancillary terrestrial network, so as to limit the aggregate radiated power by the plurality of radiotelephones to a maximum aggregate radiated power comprises controlling the plurality of radiotelephones substantially according to the following:  $N/8+M/50+L/200=R$ ; where N denotes a number of co-frequency time slots that are using the GSM air interface, M denotes a number of co-frequency codes that are using the cdma2000 air interface, L denotes a number of co-frequency codes that are using the W-CDMA air interface, and R denotes an authorized GSM-based frequency reuse.

According to another aspect, there is provided a method for controlling a satellite radiotelephone system that comprises a space-based component that is configured to communicate with a plurality of radiotelephones over a plurality of frequency bands and/or a plurality of air interfaces and an ancillary terrestrial network that is configured to communicate terrestrially with the plurality of radiotelephones over substantially the plurality of frequency bands and/or substantially the plurality of air interfaces, the method comprising: controlling the plurality of radiotelephones and/or the ancillary terrestrial network so as to limit the aggregate radiated power by the plurality of radiotelephones to a maximum aggregate radiated power; wherein controlling the plurality of radiotelephones and/or the ancillary terrestrial network, so as to limit the aggregate radiated power by the plurality of radiotelephones to a maximum aggregate radiated power is performed according to the following:

$$\sum_{i=1}^x \frac{N_i}{F_i} = \text{MARP};$$

where  $N_i$  denotes a number of co-frequency channels that are using a given frequency band and/or air interface  $i$ ,  $F_i$  denotes a corresponding equivalence factor, which may be less than, greater than or equal to 1, for the given frequency band/air interface  $i$ , and MARP is a  
 5 measure of the maximum aggregate radiated power.

According to another aspect, there is provided a method for controlling a satellite radiotelephone system that comprises a space-based component that is configured to communicate with a plurality of radiotelephones over a plurality of frequency bands and/or a plurality of air interfaces and an ancillary terrestrial network that is configured to  
 10 communicate terrestrially with the plurality of radiotelephones over substantially the plurality of frequency bands and/or substantially the plurality of air interfaces, the method comprising: controlling the plurality of radiotelephones and/or the ancillary terrestrial network so as to limit the aggregate radiated power by the plurality of radiotelephones to a maximum aggregate radiated power; wherein controlling the plurality of radiotelephones and/or the  
 15 ancillary terrestrial network, so as to limit the aggregate radiated power by the plurality of radiotelephones to a maximum aggregate radiated power is performed according to the following:

$$\sum_{i=1}^x \frac{N_i}{F_i} = \text{MARP};$$

where  $N_i$  denotes a number of co-frequency channels that are using a given structural  
 20 attenuation margin  $i$  for a given frequency band and/or air interface,  $F_i$  denotes a corresponding equivalence factor, which may be less than, greater than or equal to 1, for the given structural attenuation margin  $i$  for the given frequency band/air interface, and MARP is a measure of the maximum aggregate radiated power.

According to another aspect, there is provided a method for controlling a satellite  
 25 radiotelephone system that comprises a space-based component that is configured to communicate with a plurality of radiotelephones over a plurality of frequency bands and/or a plurality of air interfaces and an ancillary terrestrial network that is configured to communicate terrestrially with the plurality of radiotelephones over substantially the plurality of frequency bands and/or substantially the plurality of air interfaces, the method comprising:  
 30 controlling the plurality of radiotelephones and/or the ancillary terrestrial network so as to

limit the aggregate radiated power by the plurality of radiotelephones to a maximum aggregate radiated power; wherein controlling the plurality of radiotelephones and/or the ancillary terrestrial network, so as to limit the aggregate radiated power by a plurality of co-frequency radiotelephones to a maximum aggregate radiated power is performed according to  
 5 the following:

$$\sum_{i=1}^x (\text{psd})_i = \text{MARP};$$

where  $(\text{psd})_i$  denotes a measure of radiated power spectral density from an  $i^{\text{th}}$  radiotelephone at a satellite and MARP is a measure of the allowed maximum aggregate radiated power.

According to another aspect, there is provided an ancillary terrestrial network for a  
 10 satellite radiotelephone system that includes a space-based component that is configured to communicate with a plurality of radiotelephones over a satellite frequency band, the ancillary terrestrial network comprising: a plurality of ancillary terrestrial components that are configured to communicate terrestrially with the plurality of radiotelephones over  
 15 substantially the satellite frequency band; and a diversity receiver that is configured to diversity combine at least two satellite frequency band signals from a radiotelephone that are received by a first ancillary terrestrial component, that are received by a second ancillary terrestrial component and/or that are received by an auxiliary antenna system.

According to another aspect, there is provided a first ancillary terrestrial component for a satellite radiotelephone system that includes a space-based component that is configured  
 20 to communicate with a plurality of radiotelephones over a satellite frequency band, the first ancillary terrestrial component comprising: a subsystem that is configured to communicate terrestrially with the plurality of radiotelephones over substantially the satellite frequency band; and a diversity receiver that is configured to diversity combine at least two satellite frequency band signals from a radiotelephone that are received by the first ancillary terrestrial  
 25 component, by a second ancillary terrestrial component and/or by an auxiliary antenna system.

According to another aspect, there is provided a method for increasing link margin in a satellite radiotelephone system that includes a space-based component that is configured to communicate with a plurality of radiotelephones over a satellite frequency band and a  
 30 plurality of ancillary terrestrial components that are configured to communicate terrestrially with the plurality of radiotelephones over substantially the satellite frequency band, the method comprising: diversity combining at least two satellite frequency band signals from a

radiotelephone that are received by a first ancillary terrestrial component, that are received by a second ancillary terrestrial component and/or that are received by an auxiliary antenna system.

According to another aspect, there is provided an ancillary terrestrial network for a satellite radiotelephone system that includes a space-based component that is configured to communicate with a plurality of radiotelephones, the ancillary terrestrial network comprising: a plurality of ancillary terrestrial components that are configured to communicate terrestrially with the plurality of radiotelephones using satellite frequency band signals; and a diversity receiver that is configured to diversity combine at least two satellite frequency band signals from a radiotelephone that are received by a first ancillary terrestrial component, that are received by a second ancillary terrestrial component and/or that are received by an auxiliary antenna system.

According to another aspect, there is provided a first ancillary terrestrial component for a satellite radiotelephone system that includes a space-based component that is configured to communicate with a plurality of radiotelephones, the first ancillary terrestrial component comprising: a subsystem that is configured to communicate terrestrially with the plurality of radiotelephones using satellite frequency band signals; and a diversity receiver that is configured to diversity combine at least two satellite frequency band signals from a radiotelephone that are received by the first ancillary terrestrial component, by a second ancillary terrestrial component and/or by an auxiliary antenna system.

According to another aspect, there is provided a method for increasing link margin in a satellite radiotelephone system that includes a space-based component that is configured to communicate with a plurality of radiotelephones and a plurality of ancillary terrestrial components that are configured to communicate terrestrially with the plurality of radiotelephones using satellite frequency band signals, the method comprising: diversity combining at least two satellite frequency band signals from a radiotelephone that are received by a first ancillary terrestrial component, that are received by a second ancillary terrestrial component and/or that are received by an auxiliary antenna system.

According to another aspect, there is provided a method of controlling a level of interference to a wireless receiver, the method comprising: determining a set of frequencies to be assigned to a wireless transmitter responsive to a power level associated with the wireless transmitter; and assigning the set of frequencies to the wireless transmitter;

wherein determining comprises increasing a frequency distance between the set of frequencies and a band of frequencies used for reception by the wireless receiver as the power level increases; and wherein determining further comprises decreasing a frequency distance between the set of frequencies and a band of frequencies used for reception by the wireless receiver as the power level decreases.

According to another aspect, there is provided a system for controlling a level of interference to a wireless receiver, the system comprising: a wireless transmitter; and a controller that is configured to determine a set of frequencies to be assigned to a wireless transmitter responsive to a power level associated with the wireless transmitter; wherein the controller is further configured to increase a frequency distance between the set of frequencies and a band of frequencies used for reception by the wireless receiver as the power level increases; and wherein the controller is still further configured to decrease a frequency distance between the set of frequencies and a band of frequencies used for reception by the wireless receiver as the power level decreases.

According to another aspect, there is provided a radiotelephone system comprising: a wireless network that is configured to communicate bidirectionally with a plurality of radiotelephones using at least one air interface protocol and a frequency; and an aggregate radiated power controller that is configured to limit an aggregate radiated power by the plurality of radiotelephones that use the at least one air interface protocol and the frequency by controlling at least one of the radiotelephones to use another frequency that has not exceeded its maximum aggregate radiated power; wherein controlling at least one of the radiotelephones to use another frequency that has not exceeded its maximum aggregate radiated power comprises: the aggregate radiated power controller evaluating an expression that depends upon a structural attenuation margin that is provided to the at least one of the radiotelephones by the wireless network; and the aggregate radiated power controller controlling at least one of the radiotelephones to use another frequency that has not exceeded its maximum aggregate radiated power, responsive to the evaluating an expression that depends upon a structural attenuation margin that is provided to the at least one of the radiotelephones by the wireless network.

According to another aspect, there is provided a radiotelephone communications method comprising: bidirectionally communicating with a plurality of radiotelephones using

at least one air interface protocol and a frequency; and limiting an aggregate radiated power by the plurality of radiotelephones that use the at least one air interface protocol and the frequency by controlling at least one of the radiotelephones to use another frequency that has not exceeded its maximum aggregate radiated power; wherein controlling at least one of the radiotelephones to use another frequency that has not exceeded its maximum aggregate radiated power comprises: evaluating an expression that depends upon a structural attenuation margin that is provided to the at least one of the radiotelephones by a wireless network that communicates therewith; and controlling at least one of the radiotelephones to use another frequency that has not exceeded its maximum aggregate radiated power, responsive to the evaluating an expression that depends upon a structural attenuation margin that is provided to the at least one of the radiotelephones by a wireless network that communicates therewith.

According to another aspect, there is provided an apparatus for controlling a radiotelephone system that comprises a wireless network that is configured to communicate bidirectionally with a plurality of radiotelephones using at least one air interface protocol and a frequency, the apparatus comprising: an aggregate radiated power controller that is configured to limit an aggregate radiated power by the plurality of radiotelephones that use the at least one air interface protocol and the frequency by controlling at least one of the radiotelephones to use another frequency that has not exceeded its maximum aggregate radiated power; wherein controlling at least one of the radiotelephones to use another frequency that has not exceeded its maximum aggregate radiated power comprises: the aggregate radiated power controller evaluating an expression that depends upon a structural attenuation margin that is provided to the at least one of the radiotelephones by the wireless network; and the aggregate radiated power controller controlling at least one of the radiotelephones to use another frequency that has not exceeded its maximum aggregate radiated power, responsive to the evaluating an expression that depends upon a structural attenuation margin that is provided to the at least one of the radiotelephones by the wireless network.

According to another aspect, there is provided a method for controlling a radiotelephone system that comprises a wireless network that is configured to communicate bidirectionally with a plurality of radiotelephones using at least one air interface protocol and a frequency, the method comprising: limiting an aggregate radiated power by the plurality of radiotelephones that use the at least one air interface protocol and the frequency by

controlling at least one of the radiotelephones to use another frequency that has not exceeded its maximum aggregate radiated power; wherein controlling at least one of the radiotelephones to use another frequency that has not exceeded its maximum aggregate radiated power comprises: evaluating an expression that depends upon a structural  
5 attenuation margin that is provided to the at least one of the radiotelephones by the wireless network; and controlling at least one of the radiotelephones to use another frequency that has not exceeded its maximum aggregate radiated power, responsive to the evaluating an expression that depends upon a structural attenuation margin that is provided to the at least one of the radiotelephones by the wireless network.

10 According to another aspect, there is provided a method of controlling a cellular communications system, the method comprising: identifying a power level to be used by a wireless transmitter of the cellular communications system, the wireless transmitter configured to transmit over a set of frequencies that is assigned to a given cell of the cellular  
15 communications system in a band of frequencies that is assigned to the cellular communications system; determining a subset of frequencies in the set of frequencies that is assigned to the given cell, the subset of frequencies to be assigned to the wireless transmitter responsive to the identified power level to be used by the wireless transmitter; assigning the subset of frequencies in the set of frequencies that is assigned to the given cell to the wireless transmitter for transmission at the identified power level; and wherein the set of frequencies  
20 that is assigned to the given cell of the cellular communications system is in a satellite band of frequencies.

According to another aspect, there is provided a cellular communications system comprising: a wireless transmitter that is configured to transmit over a set of frequencies that is assigned to a given cell of the cellular communications system in a band of frequencies that  
25 is assigned to the cellular communications system; a controller that is configured to identify a power level to be used by the wireless transmitter and to determine a subset of frequencies in the set of frequencies that is assigned to the given cell of the cellular communications system, the subset of frequencies to be assigned to the wireless transmitter responsive to the power level that was identified; and wherein the set of frequencies that is assigned to the given cell  
30 of the cellular communications system is in a satellite band of frequencies.

**Brief Description of the Drawings**

Figure 1 is a schematic diagram of cellular radiotelephone systems and methods according to embodiments of the invention.

5 Figure 2 is a block diagram of adaptive interference reducers according to embodiments of the present invention.

Figure 3 is a spectrum diagram that illustrates satellite L-band frequency allocations.

Figure 4 is a schematic diagram of cellular satellite systems and methods according to other embodiments of the present invention.

10 Figure 5 illustrates time division duplex frame structures according to embodiments of the present invention.

Figure 6 is a block diagram of architectures of ancillary terrestrial components according to embodiments of the invention.

Figure 7 is a block diagram of architectures of reconfigurable radiotelephones according to embodiments of the invention.

15 Figure 8 graphically illustrates mapping of monotonically decreasing power levels to frequencies according to embodiments of the present invention.

Figure 9 illustrates an ideal cell that is mapped to three power regions and three associated carrier frequencies according to embodiments of the invention.

Figure 10 depicts a realistic cell that is mapped to three power regions and three associated carrier frequencies according to embodiments of the invention.

Figure 11 illustrates two or more contiguous slots in a frame that are unoccupied according to embodiments of the present invention.

5 Figure 12 illustrates loading of two or more contiguous slots with lower power transmissions according to embodiments of the present invention.

Figure 13 is a block diagram of satellite radiotelephone systems and methods according to some embodiments of the invention.

10 Figure 14 is a schematic diagram of terrestrial frequency reuse of satellite frequencies according to some embodiments of the invention.

Figure 15 is a block diagram of radiotelephones according to some embodiments of the invention.

Figure 16 is a schematic diagram of satellite radiotelephone systems and methods according to some embodiments of the invention.

15 Figure 17 is a schematic diagram of satellite radiotelephone systems and methods according to some embodiments of the invention.

Figure 18 is a schematic diagram of satellite radiotelephone systems and methods including aggregate radiated power control according to some embodiments of the present invention.

20 Figure 19 is a schematic diagram of an ancillary terrestrial network including systems and methods that can increase link margins according to some embodiments of the present invention.

### **Detailed Description of Preferred Embodiments**

25 The present invention now will be described more fully hereinafter with reference to the accompanying drawings, in which embodiments of the invention are shown. However, this invention should not be construed as limited to the embodiments set forth herein. Rather, these embodiments are provided so that this disclosure will be thorough and complete, and will fully convey the scope of the invention to those skilled in the art. Like numbers refer to  
30 like elements throughout.

Figure 1 is a schematic diagram of cellular satellite radiotelephone systems and methods according to embodiments of the invention. As shown in Figure 1, these cellular satellite radiotelephone systems and methods **100** include at least one Space-Based Component (SBC) **110**, such as a satellite. The space-based component **110** is configured to

transmit wireless communications to a plurality of radiotelephones **120a**, **120b** in a satellite footprint comprising one or more satellite radiotelephone cells **130-130''''** over one or more satellite radiotelephone forward link (downlink) frequencies  $f_D$ . The space-based component **110** is configured to receive wireless communications from, for example, a first

5 radiotelephone **120a** in the satellite radiotelephone cell **130** over a satellite radiotelephone return link (uplink) frequency  $f_U$ . An ancillary terrestrial network, comprising at least one ancillary terrestrial component **140**, which may include an antenna **140a** and an electronics system **140b** (for example, at least one antenna **140a** and at least one electronics system **140b**), is configured to receive wireless communications from, for example, a second

10 radiotelephone **120b** in the radiotelephone cell **130** over the satellite radiotelephone uplink frequency, denoted  $f_U$ , which may be the same as  $f_U$ . Thus, as illustrated in Figure 1, radiotelephone **120a** may be communicating with the space-based component **110** while radiotelephone **120b** may be communicating with the ancillary terrestrial component **140**. As shown in Figure 1, the space-based component **110** also undesirably receives the wireless

15 communications from the second radiotelephone **120b** in the satellite radiotelephone cell **130** over the satellite radiotelephone frequency  $f_U$  as interference. More specifically, a potential interference path is shown at **150**. In this potential interference path **150**, the return link signal of the second radiotelephone **120b** at carrier frequency  $f_U$  interferes with satellite communications. This interference would generally be strongest when  $f_U = f_U$ , because, in

20 that case, the same return link frequency would be used for space-based component and ancillary terrestrial component communications over the same satellite radiotelephone cell, and no spatial discrimination between satellite radiotelephone cells would appear to exist.

Still referring to Figure 1, embodiments of satellite radiotelephone systems/methods **100** can include at least one gateway **160** that can include an antenna **160a** and an electronics

25 system **160b** that can be connected to other networks **162** including terrestrial and/or other radiotelephone networks. The gateway **160** also communicates with the space-based component **110** over a satellite feeder link **112**. The gateway **160** also communicates with the ancillary terrestrial component **140**, generally over a terrestrial link **142**.

Still referring to Figure 1, an Interference Reducer (IR) **170a** also may be provided at

30 least partially in the ancillary terrestrial component electronics system **140b**. Alternatively or additionally, an interference reducer **170b** may be provided at least partially in the gateway electronics system **160b**. In yet other alternatives, the interference reducer may be provided at least partially in other components of the cellular satellite system/method **100** instead of or in addition to the interference reducer **170a** and/or **170b**. The interference reducer is

responsive to the space-based component **110** and to the ancillary terrestrial component **140**, and is configured to reduce the interference from the wireless communications that are received by the space-based component **110** and is at least partially generated by the second radiotelephone **120b** in the satellite radiotelephone cell **130** over the satellite radiotelephone frequency  $f_U$ . The interference reducer **170a** and/or **170b** uses the wireless communications  $f_U$  that are intended for the ancillary terrestrial component **140** from the second radiotelephone **120b** in the satellite radiotelephone cell **130** using the satellite radiotelephone frequency  $f_U$  to communicate with the ancillary terrestrial component **140**.

In embodiments of the invention, as shown in Figure 1, the ancillary terrestrial component **140** generally is closer to the first and second radiotelephones **120a** and **120b**, respectively, than is the space-based component **110**, such that the wireless communications from the second radiotelephone **120b** are received by the ancillary terrestrial component **140** prior to being received by the space-based component **110**. The interference reducer **170a** and/or **170b** is configured to generate an interference cancellation signal comprising, for example, at least one delayed replica of the wireless communications from the second radiotelephone **120b** that are received by the ancillary terrestrial component **140**, and to subtract the delayed replica of the wireless communications from the second radiotelephone **120b** that are received by the ancillary terrestrial component **140** from the wireless communications that are received from the space-based component **110**. The interference reduction signal may be transmitted from the ancillary terrestrial component **140** to the gateway **160** over link **142** and/or using other conventional techniques.

Thus, adaptive interference reduction techniques may be used to at least partially cancel the interfering signal, so that the same, or other nearby, satellite radiotelephone uplink frequency can be used in a given cell for communications by radiotelephones **120** with the satellite **110** and with the ancillary terrestrial component **140**. Accordingly, all frequencies that are assigned to a given cell **130** may be used for both radiotelephone **120** communications with the space-based component **110** and with the ancillary terrestrial component **140**. Conventional systems may avoid terrestrial reuse of frequencies within a given satellite cell that are being used within the satellite cell for satellite communications. Stated differently, conventionally, only frequencies used by other satellite cells may be candidates for terrestrial reuse within a given satellite cell. Beam-to-beam spatial isolation that is provided by the satellite system was relied upon to reduce or minimize the level of interference from the terrestrial operations into the satellite operations. In sharp contrast, embodiments of the invention can use an interference reducer to allow all frequencies

assigned to a satellite cell to be used terrestrially and for satellite radiotelephone communications.

Embodiments of the invention according to Figure 1 may arise from a realization that the return link signal from the second radiotelephone **120b** at  $f_U$  generally will be received and processed by the ancillary terrestrial component **140** much earlier relative to the time when it will arrive at the satellite gateway **160** from the space-based component **110** via the interference path **150**. Accordingly, the interference signal at the satellite gateway **160b** can be at least partially canceled. Thus, as shown in Figure 1, an interference cancellation signal, such as the demodulated ancillary terrestrial component signal, can be sent to the satellite gateway **160b** by the interference reducer **170a** in the ancillary terrestrial component **140**, for example using link **142**. In the interference reducer **170b** at the gateway **160b**, a weighted (in amplitude and/or phase) replica of the signal may be formed using, for example, adaptive transversal filter techniques that are well known to those having skill in the art. Then, a transversal filter output signal is subtracted from the aggregate received satellite signal at frequency  $f_U$  that contains desired as well as interference signals. Thus, the interference cancellation need not degrade the signal-to-noise ratio of the desired signal at the gateway **160**, because a regenerated (noise-free) terrestrial signal, for example as regenerated by the ancillary terrestrial component **140**, can be used to perform interference suppression.

Figure 2 is a block diagram of embodiments of adaptive interference cancellers that may be located in the ancillary terrestrial component **140**, in the gateway **160**, and/or in another component of the cellular radiotelephone system **100**. As shown in Figure 2, one or more control algorithms **204**, known to those having skill in the art, may be used to adaptively adjust the coefficients of a plurality of transversal filters **202a-202n**. Adaptive algorithms, such as Least Mean Square Error (LMSE), Kalman, Fast Kalman, Zero Forcing and/or various combinations thereof or other techniques may be used. It will be understood by those having skill in the art that the architecture of Figure 2 may be used with an LMSE algorithm. However, it also will be understood by those having skill in the art that conventional architectural modifications may be made to facilitate other control algorithms.

Additional embodiments of the invention now will be described with reference to Figure 3, which illustrates L-band frequency allocations including cellular radiotelephone system forward links and return links. As shown in Figure 3, the space-to-ground L-band forward link (downlink) frequencies are assigned from 1525 MHz to 1559 MHz. The ground-to-space L-band return link (uplink) frequencies occupy the band from 1626.5 MHz

to 1660.5 MHz. Between the forward and return L-band links lie the GPS/GLONASS radionavigation band (from 1559 MHz to 1605 MHz).

In the detailed description to follow, GPS/GLONASS will be referred to simply as GPS for the sake of brevity. Moreover, the acronyms ATC and SBC will be used for the ancillary terrestrial component and the space-based component, respectively, for the sake of  
5 brevity.

As is known to those skilled in the art, GPS receivers may be extremely sensitive since they are designed to operate on very weak spread-spectrum radionavigation signals that arrive on the earth from a GPS satellite constellation. As a result, GPS receivers may to be  
10 highly susceptible to in-band interference. ATCs that are configured to radiate L-band frequencies in the forward satellite band (1525 to 1559 MHz) can be designed with very sharp out-of-band emissions filters to satisfy the stringent out-of-band spurious emissions desires of GPS.

Referring again to Figure 1, some embodiments of the invention can provide systems  
15 and methods that can allow an ATC **140** to configure itself in one of at least two modes. In accordance with a first mode, which may be a standard mode and may provide highest capacity, the ATC **140** transmits to the radiotelephones **120** over the frequency range from 1525 MHz to 1559 MHz, and receives transmissions from the radiotelephones **120** in the frequency range from 1626.5 MHz to 1660.5 MHz, as illustrated in Figure 3. In contrast, in a  
20 second mode of operation, the ATC **140** transmits wireless communications to the radiotelephones **120** over a modified range of satellite band forward link (downlink) frequencies. The modified range of satellite band forward link frequencies may be selected to reduce, compared to the unmodified range of satellite band forward link frequencies, interference with wireless receivers such as GPS receivers that operate outside the range of  
25 satellite band forward link frequencies.

Many modified ranges of satellite band forward link frequencies may be provided according to embodiments of the present invention. In some embodiments, the modified range of satellite band forward link frequencies can be limited to a subset of the original range of satellite band forward link frequencies, so as to provide a guard band of unused  
30 satellite band forward link frequencies. In other embodiments, all of the satellite band forward link frequencies are used, but the wireless communications to the radiotelephones are modified in a manner to reduce interference with wireless receivers that operate outside the range of satellite band forward link frequencies. Combinations and subcombinations of these and/or other techniques also may be used, as will be described below.

It also will be understood that embodiments of the invention that will now be described in connection with Figures 4-12 will be described in terms of multiple mode ATCs **140** that can operate in a first standard mode using the standard forward and return links of Figure 3, and in a second or alternate mode that uses a modified range of satellite band forward link frequencies and/or a modified range of satellite band return link frequencies. These multiple mode ATCs can operate in the second, non-standard mode, as long as desirable, and can be switched to standard mode otherwise. However, other embodiments of the present invention need not provide multiple mode ATCs but, rather, can provide ATCs that operate using the modified range of satellite band forward link and/or return link frequencies.

Embodiments of the invention now will be described, wherein an ATC operates with an SBC that is configured to receive wireless communications from radiotelephones over a first range of satellite band return link frequencies and to transmit wireless communications to the radiotelephones over a second range of satellite band forward link frequencies that is spaced apart from the first range. According to these embodiments, the ATC is configured to use at least one time division duplex frequency to transmit wireless communications to the radiotelephones and to receive wireless communications from the radiotelephones at different times. In particular, in some embodiments, the at least one time division duplex frequency that is used to transmit wireless communications to the radiotelephones and to receive wireless communications from the radiotelephones at different times, comprises a frame including a plurality of slots. At least a first one of the slots is used to transmit wireless communications to the radiotelephones and at least a second one of the slots is used to receive wireless communications from the radiotelephones. Thus, in some embodiments, the ATC transmits and receives, in Time Division Duplex (TDD) mode, using frequencies from 1626.5 MHz to 1660.5 MHz. In some embodiments, all ATCs across the entire network may have the stated configuration/reconfiguration flexibility. In other embodiments, only some ATCs may be reconfigurable.

Figure 4 illustrates satellite systems and methods **400** according to some embodiments of the invention, including an ATC **140** communicating with a radiotelephone **120b** using a carrier frequency  $f''_v$  in TDD mode. Figure 5 illustrates an embodiment of a TDD frame structure. Assuming full-rate GSM (eight time slots per frame), up to four full-duplex voice circuits can be supported by one TDD carrier. As shown in Figure 5, the ATC **140** transmits to the radiotelephone **120b** over, for example, time slot number 0. The radiotelephone **120b**

receives and replies back to the ATC **140** over, for example, time slot number 4. Time slots number 1 and 5 may be used to establish communications with another radiotelephone, and so on.

A Broadcast Control CHannel (BCCH) is preferably transmitted from the ATC **140** in standard mode, using a carrier frequency from below any guard band exclusion region. In other embodiments, a BCCH also can be defined using a TDD carrier. In any of these embodiments, radiotelephones in idle mode can, per established GSM methodology, monitor the BCCH and receive system-level and paging information. When a radiotelephone is paged, the system decides what type of resource to allocate to the radiotelephone in order to establish the communications link. Whatever type of resource is allocated for the radiotelephone communications channel (TDD mode or standard mode), the information is communicated to the radiotelephone, for example as part of the call initialization routine, and the radiotelephone configures itself appropriately.

It may be difficult for the TDD mode to co-exist with the standard mode over the same ATC, due, for example, to the ATC receiver LNA stage. In particular, assuming a mixture of standard and TDD mode GSM carriers over the same ATC, during the part of the frame when the TDD carriers are used to serve the forward link (when the ATC is transmitting TDD) enough energy may leak into the receiver front end of the same ATC to desensitize its LNA stage.

Techniques can be used to suppress the transmitted ATC energy over the 1600 MHz portion of the band from desensitizing the ATC's receiver LNA, and thereby allow mixed standard mode and TDD frames. For example, isolation between outbound and inbound ATC front ends and/or antenna system return loss may be increased or maximized. A switchable band-reject filter may be placed in front of the LNA stage. This filter would be switched in the receiver chain (prior to the LNA) during the part of the frame when the ATC is transmitting TDD, and switched out during the rest of the time. An adaptive interference canceller can be configured at RF (prior to the LNA stage). If such techniques are used, suppression of the order of 70 dB can be attained, which may allow mixed standard mode and TDD frames. However, the ATC complexity and/or cost may increase.

Thus, even though ATC LNA desensitization may be reduced or eliminated, it may use significant special engineering and attention and may not be economically worth the effort. Other embodiments, therefore, may keep TDD ATCs pure TDD, with the exception, perhaps, of the BCCH carrier which may not be used for traffic but only for broadcasting over the first part of the frame, consistent with TDD protocol. Moreover, Random Access

CHannel (RACH) bursts may be timed so that they arrive at the ATC during the second half of the TDD frame. In some embodiments, all TDD ATCs may be equipped to enable reconfiguration in response to a command.

It is well recognized that during data communications or other applications, the forward link may use transmissions at higher rates than the return link. For example, in web browsing with a radiotelephone, mouse clicks and/or other user selections typically are transmitted from the radiotelephone to the system. The system, however, in response to a user selection, may have to send large data files to the radiotelephone. Hence, other embodiments of the invention may be configured to enable use of an increased or maximum number of time slots per forward GSM carrier frame, to provide a higher downlink data rate to the radiotelephones.

Thus, when a carrier frequency is configured to provide service in TDD mode, a decision may be made as to how many slots will be allocated to serving the forward link, and how many will be dedicated to the return link. Whatever the decision is, it may be desirable that it be adhered to by all TDD carriers used by the ATC, in order to reduce or avoid the LNA desensitization problem described earlier. In voice communications, the partition between forward and return link slots may be made in the middle of the frame as voice activity typically is statistically bidirectionally symmetrical. Hence, driven by voice, the center of the frame may be where the TDD partition is drawn.

To increase or maximize forward link throughput in data mode, data mode TDD carriers according to embodiments of the invention may use a more spectrally efficient modulation and/or protocol, such as the EDGE modulation and/or protocol, on the forward link slots. The return link slots may be based on a less spectrally efficient modulation and/or protocol such as the GPRS (GMSK) modulation and/or protocol. The EDGE modulation/protocol and the GPRS modulation/protocol are well known to those having skill in the art, and need not be described further herein. Given an EDGE forward/GPRS return TDD carrier strategy, up to  $(384/2) = 192$  kbps may be supported on the forward link while on the return link the radiotelephone may transmit at up to  $(115/2) \approx 64$  kbps.

In other embodiments, it also is possible to allocate six time slots of an eight-slot frame for the forward link and only two for the return link. In these embodiments, for voice services, given the statistically symmetric nature of voice, the return link vocoder may need to be comparable with quarter-rate GSM, while the forward link vocoder can operate at full-rate GSM, to yield six full-duplex voice circuits per GSM TDD-mode carrier (a voice

capacity penalty of 25%). Subject to this non-symmetrical partitioning strategy, data rates of up to  $(384)(6/8) = 288$  kbps may be achieved on the forward link, with up to  $(115)(2/8) \approx 32$  kbps on the return link.

Figure 6 depicts an ATC architecture according to embodiments of the invention, which can lend itself to automatic configuration between the two modes of standard GSM and TDD GSM on command, for example, from a Network Operations Center (NOC) via a Base Station Controller (BSC). It will be understood that in these embodiments, an antenna **620** can correspond to the antenna **140a** of Figures 1 and 4, and the remainder of Figure 6 can correspond to the electronics system **140b** of Figures 1 and 4. If a reconfiguration command for a particular carrier, or set of carriers, occurs while the carrier(s) are active and are supporting traffic, then, via the in-band signaling Fast Associated Control Channel (FACCH), all affected radiotelephones may be notified to also reconfigure themselves and/or switch over to new resources. If carrier(s) are reconfigured from TDD mode to standard mode, automatic reassignment of the carrier(s) to the appropriate standard-mode ATCs, based, for example, on capacity demand and/or reuse pattern can be initiated by the NOC. If, on the other hand, carrier(s) are reconfigured from standard mode to TDD mode, automatic reassignment to the appropriate TDD-mode ATCs can take place on command from the NOC.

Still referring to Figure 6, a switch **610** may remain closed when carriers are to be demodulated in the standard mode. In TDD mode, this switch **610** may be open during the first half of the frame, when the ATC is transmitting, and closed during the second half of the frame, when the ATC is receiving. Other embodiments also may be provided.

Figure 6 assumes N transceivers per ATC sector, where N can be as small as one, since a minimum of one carrier per sector generally is desired. Each transceiver is assumed to operate over one GSM carrier pair (when in standard mode) and can thus support up to eight full-duplex voice circuits, neglecting BCCH channel overhead. Moreover, a standard GSM carrier pair can support sixteen full-duplex voice circuits when in half-rate GSM mode, and up to thirty two full-duplex voice circuits when in quarter-rate GSM mode.

When in TDD mode, the number of full duplex voice circuits may be reduced by a factor of two, assuming the same vocoder. However, in TDD mode, voice service can be offered via the half-rate GSM vocoder with almost imperceptible quality degradation, in order to maintain invariant voice capacity. Figure 7 is a block diagram of a reconfigurable radiotelephone architecture that can communicate with a reconfigurable ATC architecture of

Figure 6. In Figure 7, an antenna 720 is provided, and the remainder of Figure 7 can provide embodiments of an electronics system for the radiotelephone.

It will be understood that the ability to reconfigure ATCs and radiotelephones according to embodiments of the invention may be obtained at a relatively small increase in cost. The cost may be mostly in Non-Recurring Engineering (NRE) cost to develop software. Some recurring cost may also be incurred, however, in that at least an additional RF filter and a few electronically controlled switches may be used per ATC and radiotelephone. All other hardware/software can be common to standard-mode and TDD-mode GSM.

Referring now to Figure 8, other radiotelephone systems and methods according to embodiments of the invention now will be described. In these embodiments, the modified second range of satellite band forward link frequencies includes a plurality of frequencies in the second range of satellite band forward link frequencies that are transmitted by the ATCs to the radiotelephones at a power level, such as maximum power level, that monotonically decreases as a function of (increasing) frequency. More specifically, as will be described below, in some embodiments, the modified second range of satellite band forward link frequencies includes a subset of frequencies proximate to a first or second end of the range of satellite band forward link frequencies that are transmitted by the ATC to the radiotelephones at a power level, such as a maximum power level, that monotonically decreases toward the first or second end of the second range of satellite band forward link frequencies. In still other embodiments, the first range of satellite band return link frequencies is contained in an L-band of satellite frequencies above GPS frequencies and the second range of satellite band forward link frequencies is contained in the L-band of satellite frequencies below the GPS frequencies. The modified second range of satellite band forward link frequencies includes a subset of frequencies proximate to an end of the second range of satellite band forward link frequencies adjacent the GPS frequencies that are transmitted by the ATC to the radiotelephones at a power level, such as a maximum power level, that monotonically decreases toward the end of the second range of satellite band forward link frequencies adjacent the GPS frequencies.

Without being bound by any theory of operation, a theoretical discussion of the mapping of ATC maximum power levels to carrier frequencies according to embodiments of the present invention now will be described. Referring to Figure 8, let  $v = \mathcal{F}(\rho)$  represent a mapping from the power ( $\rho$ ) domain to the frequency ( $v$ ) range. The power ( $\rho$ ) is the power that an ATC uses or should transmit in order to reliably communicate with a given

radiotelephone. This power may depend on many factors such as the radiotelephone's distance from the ATC, the blockage between the radiotelephone and the ATC, the level of multipath fading in the channel, etc., and as a result, will, in general, change as a function of time. Hence, the power used generally is determined adaptively (iteratively) via closed-loop  
5 power control, between the radiotelephone and ATC.

The frequency ( $\nu$ ) is the satellite carrier frequency that the ATC uses to communicate with the radiotelephone. According to embodiments of the invention, the mapping  $\mathcal{F}$  is a monotonically decreasing function of the independent variable  $\rho$ . Consequently, in some embodiments, as the maximum ATC power increases, the carrier frequency that the ATC  
10 uses to establish and/or maintain the communications link decreases. Figure 8 illustrates an embodiment of a piece-wise continuous monotonically decreasing (stair-case) function. Other monotonic functions may be used, including linear and/or nonlinear, constant and/or variable decreases. FACCH or Slow Associated Control CHannel (SACCH) messaging may be used in embodiments of the invention to facilitate the mapping adaptively and in  
15 substantially real time.

Figure 9 depicts an ideal cell according to embodiments of the invention, where, for illustration purposes, three power regions and three associated carrier frequencies (or carrier frequency sets) are being used to partition a cell. For simplicity, one ATC transmitter at the center of the idealized cell is assumed with no sectorization. In embodiments of Figure 9, the  
20 frequency (or frequency set)  $f_1$  is taken from substantially the upper-most portion of the L-band forward link frequency set, for example from substantially close to 1559 MHz (see Figure 3). Correspondingly, the frequency (or frequency set)  $f_M$  is taken from substantially the central portion of the L-band forward link frequency set (see Figure 3). In concert with the above, the frequency (or frequency set)  $f_0$  is taken from substantially the lowest portion  
25 of the L-band forward link frequencies, for example close to 1525 MHz (see Figure 3).

Thus, according to embodiments of Figure 9, if a radiotelephone is being served within the outer-most ring of the cell, that radiotelephone is being served via frequency  $f_0$ . This radiotelephone, being within the furthest area from the ATC, has (presumably) requested maximum (or near maximum) power output from the ATC. In response to the maximum (or  
30 near maximum) output power request, the ATC uses its a priori knowledge of power-to-frequency mapping, such as a three-step staircase function of Figure 9. Thus, the ATC serves the radiotelephone with a low-value frequency taken from the lowest portion of the mobile L-band forward link frequency set, for example, from as close to 1525 MHz as possible. This,

then, can provide additional safeguard to any GPS receiver unit that may be in the vicinity of the ATC.

Embodiments of Figure 9 may be regarded as idealized because they associate concentric ring areas with carrier frequencies (or carrier frequency sets) used by an ATC to serve its area. In reality, concentric ring areas generally will not be the case. For example, a radiotelephone can be close to the ATC that is serving it, but with significant blockage between the radiotelephone and the ATC due to a building. This radiotelephone, even though relatively close to the ATC, may also request maximum (or near maximum) output power from the ATC. With this in mind, Figure 10 may depict a more realistic set of area contours that may be associated with the frequencies being used by the ATC to serve its territory, according to embodiments of the invention. The frequency (or frequency set)  $f_1$  may be reused in the immediately adjacent ATC cells owing to the limited geographical span associated with  $f_1$  relative to the distance between cell centers. This may also hold for  $f_M$ .

Referring now to Figure 11, other modified second ranges of satellite band forward link frequencies that can be used by ATCs according to embodiments of the present invention now will be described. In these embodiments, at least one frequency in the modified second range of satellite band forward link frequencies that is transmitted by the ATC to the radiotelephones comprises a frame including a plurality of slots. In these embodiments, at least two contiguous slots in the frame that is transmitted by the ATC to the radiotelephones are left unoccupied. In other embodiments, three contiguous slots in the frame that is transmitted by the ATC to the radiotelephones are left unoccupied. In yet other embodiments, at least two contiguous slots in the frame that is transmitted by the ATC to the radiotelephones are transmitted at lower power than remaining slots in the frame. In still other embodiments, three contiguous slots in the frame that is transmitted by the ATC to the radiotelephones are transmitted at lower power than remaining slots in the frame. In yet other embodiments, the lower power slots may be used with first selected ones of the radiotelephones that are relatively close to the ATC and/or are experiencing relatively small signal blockage, and the remaining slots are transmitted at higher power to second selected ones of the radiotelephones that are relatively far from the ATC and/or are experiencing relatively high signal blockage.

Stated differently, in accordance with some embodiments of the invention, only a portion of the TDMA frame is utilized. For example, only the first four (or last four, or any contiguous four) time slots of a full-rate GSM frame are used to support traffic. The remaining slots are left unoccupied (empty). In these embodiments, capacity may be lost.

However, as has been described previously, for voice services, half-rate and even quarter-rate GSM may be invoked to gain capacity back, with some potential degradation in voice quality. The slots that are not utilized preferably are contiguous, such as slots 0 through 3 or 4 through 7 (or 2 through 5, etc.). The use of non-contiguous slots such as 0, 2, 4, and 6, for example, may be less desirable. Figure 11 illustrates four slots (4-7) being used and four contiguous slots (0-3) being empty in a GSM frame.

It has been found experimentally, according to these embodiments of the invention, that GPS receivers can perform significantly better when the interval between interference bursts is increased or maximized. Without being bound by any theory of operation, this effect may be due to the relationship between the code repetition period of the GPS C/A code (1 msec.) and the GSM burst duration (about 0.577 msec.). With a GSM frame occupancy comprising alternate slots, each GPS signal code period can experience at least one "hit", whereas a GSM frame occupancy comprising four to five contiguous slots allows the GPS receiver to derive sufficient clean information, so as to "flywheel" through the error events.

According to other embodiments of the invention, embodiments of Figures 8-10 can be combined with embodiments of Figure 11. Furthermore, according to other embodiments of the invention, if an  $f_1$  carrier of Figures 9 or 10 is underutilized, because of the relatively small footprint of the inner-most region of the cell, it may be used to support additional traffic over the much larger outermost region of the cell.

Thus, for example, assume that only the first four slots in each frame of  $f_1$  are being used for inner region traffic. In embodiments of Figures 8-10, these four  $f_1$  slots are carrying relatively low power bursts, for example of the order of 100 mW or less, and may, therefore, appear as (almost) unoccupied from an interference point of view. Loading the remaining four (contiguous) time slots of  $f_1$  with relatively high-power bursts may have negligible effect on a GPS receiver because the GPS receiver would continue to operate reliably based on the benign contiguous time interval occupied by the four low-power GSM bursts. Figure 12 illustrates embodiments of a frame at carrier  $f_1$  supporting four low-power (inner interval) users and four high-power (outer interval) users. In fact, embodiments illustrated in Figure 12 may be a preferred strategy for the set of available carrier frequencies that are closest to the GPS band. These embodiments may avoid undue capacity loss by more fully loading the carrier frequencies.

The experimental finding that interference from GSM carriers can be relatively benign to GPS receivers provided that no more than, for example, 5 slots per 8 slot GSM frame are used in a contiguous fashion can be very useful. It can be particularly useful since

this experimental finding may hold even when the GSM carrier frequency is brought very close to the GPS band (as close as 1558.5 MHz) and the power level is set relatively high. For example, with five contiguous time slots per frame populated, the worst-case measured GPS receiver may attain at least 30 dB of desensitization margin, over the entire ATC service  
5 area, even when the ATC is radiating at 1558.5 MHz. With four contiguous time slots per frame populated, an additional 10 dB desensitization margin may be gained for a total of 40 dB for the worst-case measured GPS receiver, even when the ATC is radiating at 1558.5 MHz.

There still may be concern about the potential loss in network capacity (especially in  
10 data mode) that may be incurred over the frequency interval where embodiments of Figure 11 are used to underpopulate the frame. Moreover, even though embodiments of Figure 12 can avoid capacity loss by fully loading the carrier, they may do so subject to the constraint of filling up the frame with both low-power and high-power users. Moreover, if forward link carriers are limited to 5 contiguous high power slots per frame, the maximum forward link  
15 data rate per carrier that may be aimed at a particular user may become proportionately less.

Therefore, in other embodiments, carriers which are subject to contiguous empty/low power slots are not used for the forward link. Instead, they are used for the return link. Consequently, in some embodiments, at least part of the ATC is configured in reverse frequency mode compared to the SBC in order to allow maximum data rates over the forward  
20 link throughout the entire network. On the reverse frequency return link, a radiotelephone may be limited to a maximum of 5 slots per frame, which can be adequate for the return link. Whether the five available time slots per frame, on a reverse frequency return link carrier, are assigned to one radiotelephone or to five different radiotelephones, they can be assigned contiguously in these embodiments. As was described in connection with Figure 12, these  
25 five contiguous slots can be assigned to high-power users while the remaining three slots may be used to serve low-power users.

Other embodiments may be based on operating the ATC entirely in reverse frequency mode compared to the SBC. In these embodiments, an ATC transmits over the satellite return link frequencies while radiotelephones respond over the satellite forward link  
30 frequencies. If sufficient contiguous spectrum exists to support CDMA technologies, and in particular the emerging Wideband-CDMA 3G standard, the ATC forward link can be based on Wideband-CDMA to increase or maximize data throughput capabilities. Interference with GPS may not be an issue since the ATCs transmit over the satellite return link in these embodiments. Instead, interference may become a concern for the radiotelephones. Based,

however, on embodiments of Figures 11-12, the radiotelephones can be configured to transmit GSM since ATC return link rates are expected, in any event, to be lower than those of the forward link. Accordingly, the ATC return link may employ GPRS-based data modes, possibly even EDGE. Thus, return link carriers that fall within a predetermined frequency interval from the GPS band-edge of 1559 MHz, can be under loaded, per embodiments of  
5 Figures 11 or 12, to satisfy GPS interference concerns.

Finally, other embodiments may use a partial or total reverse frequency mode and may use CDMA on both forward and return links. In these embodiments, the ATC forward link to the radiotelephones utilizes the frequencies of the satellite return link (1626.5 MHz to  
10 1660.5 MHz) whereas the ATC return link from the radiotelephones uses the frequencies of the satellite forward link (1525 MHz to 1559 MHz). The ATC forward link can be based on an existing or developing CDMA technology (e.g., IS-95, Wideband-CDMA, etc.). The ATC network return link can also be based on an existing or developing CDMA technology provided that the radiotelephone's output is gated to cease transmissions for approximately 3  
15 msec once every T msec. In some embodiments, T will be greater than or equal to 6 msec.

This gating may not be needed for ATC return link carriers at approximately 1550 MHz or below. This gating can reduce or minimize out-of-band interference (desensitization) effects for GPS receivers in the vicinity of an ATC. To increase the benefit to GPS, the gating between all radiotelephones over an entire ATC service area can be  
20 substantially synchronized. Additional benefit to GPS may be derived from system-wide synchronization of gating. The ATCs can instruct all active radiotelephones regarding the gating epoch. All ATCs can be mutually synchronized via GPS.

#### Multi-Band/Multi-Mode Satellite Radiotelephone Communications Systems and Methods

25 Some embodiments of the present invention that were described above may use the same satellite radiotelephone link band and satellite feeder link band for space-based communications with radiotelephones in all satellite cells of the satellite footprint or service area. Moreover, some embodiments of the present invention that were described above may use the same satellite radio frequency band and substantially the same air interface for  
30 terrestrial communications with radiotelephones using an ancillary terrestrial network. Other embodiments of the present invention that will now be described may use more than one band and/or more than one air interface in various satellite cells in the satellite footprint or service area. In still other embodiments, although different bands and/or different air interfaces may be used in different satellite cells or within a satellite cell, the satellite

radiotelephone frequency band and the air interface that is used for terrestrial communications between an ancillary terrestrial network and radiotelephones within a given satellite cell, is substantially the same as is used for space-based communications with the radiotelephones within the given satellite cell or in different satellite cells.

5 As used herein, "substantially the same" band means that the bands substantially overlap, but that there may be some areas of non-overlap, for example at the band ends. Moreover, "substantially the same" air interface means that the air interfaces are similar but need not be identical. Some changes may be made to the air interface to account for different characteristics for the terrestrial and satellite environments. For example, a different vocoder  
10 rate may be used (for example, 13kbps for GSM and 4kbps for satellite), a different forward error correction coding and/or a different interleaving depth may be used.

Multi-band/multi-mode satellite radiotelephone communications systems and methods according to some embodiments of the present invention may be used when a satellite footprint or service area spans a geographic area in which two or more terrestrial  
15 radiotelephone systems (wireless network operators) are present, to add space-based communications capability to two or more terrestrial networks. Within a geographic area that is covered by a given terrestrial radiotelephone system, embodiments of the invention can provide additional capacity and/or extended services using the space-based component and/or the ancillary terrestrial network, using substantially the same band and/or air interface as the  
20 terrestrial radiotelephone system. Thus, different geographic regions corresponding to different terrestrial radiotelephone communications systems and methods according to embodiments of the invention may use different bands and/or air interfaces for compatibility with the terrestrial radiotelephone systems that are located within the different geographic areas. There also may be other scenarios wherein it may be desired for a single satellite  
25 radiotelephone communications system/method to employ different bands and/or air interfaces over the same and/or different geographic regions thereof.

Figure 16 is a schematic diagram of satellite radiotelephone systems and methods according to some embodiments of the invention. As shown in Figure 16, these embodiments of satellite radiotelephone systems and methods include a space-based component **1610** that  
30 is configured to communicate with radiotelephones **1620a-1620c** in a satellite footprint **1630** that is divided into a plurality of satellite cells **1640a-1640c**. It will be understood by those having skill in the art that, although three satellite cells **1640a-1640c** and three radiotelephones **1620a-1620c** are illustrated in Figure 16, satellite radiotelephone systems

and methods according to embodiments of the present invention may employ more than three satellite cells **1640a-1640c** and may employ more than three radiotelephones **1620a-1620c**.

Still referring to Figure 16, the space-based component **1610** is configured to communicate with a first radiotelephone **1620a** in a first satellite cell **1640a** over a first  
5 frequency band and/or a first air interface, and to communicate with a second radiotelephone **1620b** in a second satellite cell **1640b** over a second frequency band and/or a second air interface. In other embodiments, the first radiotelephone **1620a** and the second radiotelephone **1620b** may be in the same satellite cell.

Still referring to Figure 16, in some embodiments of the present invention, an  
10 ancillary terrestrial network **1650** is configured to communicate terrestrially with the first radiotelephone **1620a** over substantially the first frequency band and/or substantially the first air interface, and to communicate terrestrially with the second radiotelephone **1620b** over substantially the second frequency band and/or substantially the second air interface. These substantially the same first frequency band and/or first interface in the first satellite cell  
15 **1640a** and in the portion of the ancillary terrestrial network **1650** therein, is illustrated by the vertical dashed lines that cover the first satellite cell **1640a** and the portion of the ancillary terrestrial network **1650** therein. The substantially the same second frequency band and/or second air interface in satellite cell **1640b** and in the portion of the ancillary terrestrial network **1650** therein, is illustrated by the horizontal dashed lines that cover the second  
20 satellite cell **1640b** and the portion of the ancillary terrestrial network **1650** therein.

It will be understood that in Figure 16, the ancillary terrestrial network **1650** is illustrated as including a small number of ancillary terrestrial network cells for simplicity. However, more ancillary terrestrial network cells may be present in some embodiments of the present invention. Moreover, it also will be understood that, in some embodiments, a first  
25 portion of the ancillary terrestrial network **1650** within satellite cell **1640a** may be operated by a first wireless network operator and a second portion of the ancillary terrestrial network **1650** within the first satellite cell **1640a** or within the second satellite cell **1640b** may be operated by a second wireless network operator. Accordingly, some embodiments of the invention provide systems and methods for adding space-based communications to first and  
30 second terrestrial networks.

Referring again to Figure 16, satellite radiotelephone systems and methods according to some embodiments of the present invention also include a gateway **1660** that is configured to communicate with the space-based component **1610** over a feeder link **1670**. The feeder link **1670** is configured to transport communications between the space-based component

1610 and the first and second radiotelephones 1620a, 1620b. In some embodiments, the feeder link 1670 comprises the first air interface and the second air interface. Finally, it also will be understood that a third satellite cell 1640c, a third radiotelephone 1620c, and a substantially the same third frequency band and/or air interface is illustrated by oblique  
5 dashed lines in satellite cell 1640c. In other embodiments, the third radiotelephone 1620c is in the same cell as the first radiotelephone 1620a and/or the second radiotelephone 1620b.

Figure 17 is a schematic diagram of satellite radiotelephone systems and methods according to other embodiments of the present invention. As shown in Figure 17, a space-based component 1710 is configured to communicate with a first radiotelephone 1720a over  
10 a first frequency band and/or first air interface 1780a, also designated in Figure 17 by F1/I1. As also shown in Figure 17, the space-based component 1710 is also configured to communicate with a second radiotelephone 1720b over a second frequency band and/or a second air interface 1780b, also designated in Figure 17 by F2/I2. An ancillary terrestrial network 1750 is configured to communicate terrestrially with the first radiotelephone 1720a  
15 over substantially the first frequency band and/or substantially the first air interface 1790a, also designated in Figure 17 as F1'/I1', and to communicate terrestrially with the second radiotelephone 1720b over substantially the second frequency band and/or substantially the second air interface 1790b, also designated in Figure 17 as F2'/I2'. The ancillary terrestrial network 1750 may be included within a single satellite cell or may spread across multiple  
20 satellite cells.

As also shown in Figure 17, the ancillary terrestrial network can comprise a first ancillary terrestrial component 1752a that is configured to communicate terrestrially with the first radiotelephone 1720a over substantially the first frequency band and/or substantially the first air interface 1790a. A second ancillary terrestrial component 1752b is configured to  
25 communicate terrestrially with the second radiotelephone 1720b over substantially the second frequency band and/or substantially the second air interface 1790b. As was the case in Figure 16, a large number of radiotelephones 1720 and/or ancillary terrestrial components 1752 may be provided in some embodiments. The first and second ancillary terrestrial components 1752a, 1752b, respectively, may be parts of two separate wireless networks in  
30 the same and/or different satellite cells, in some embodiments. Thus, some embodiments of Figure 17 provide systems and methods for adding space-based communications to first and second terrestrial networks. A gateway 1760 and a feeder link 1770 may be provided, as was described in connection with Figure 16.

Some embodiments of the present invention provide satellite radiotelephone systems and/or methods that include radiotelephone links that are operative over a plurality of bands. In some embodiments, the band-sensitive (i.e., frequency-sensitive) components of the space-based component **1610, 1710**, such as the antenna feed network, the power amplifiers, the low noise amplifiers, etc., may be designed to be broadband, so that the operational range of the space-based component can extend over a plurality of service link bands, such as L-band, S-band, etc. In other embodiments, separate components for each band may be provided. In still other embodiments, some common broadband components and some separate narrowband components may be provided.

Moreover, other embodiments of the present invention may provide a multi-mode payload capacity, by providing a plurality of air interfaces that may be used to provide radiotelephone communications with the space-based component **1610, 1710** and a plurality of radiotelephones **1620, 1720** in a satellite footprint over the same and/or a plurality of satellite cells. The space-based component **1610, 1710** may be configured to support a plurality of air interface standards, for example by having a programmable channel increment that can be responsive to ground commands. Different channel increments, for example, may be applied by the space-based components **1620, 1720** to different bands of the received feeder link signal **1670, 1770** from a gateway **1660, 1760**. These different bands of the feeder link spectrum may remain constant or may change with time, depending on the traffic carried by each air interface standard that may be supported by the satellite radiotelephone system.

Thus, in some embodiments, the feeder link **1670, 1770** may be segmented into bands, such as bands  $B_1$ ,  $B_2$  and  $B_3$ . In one example, band  $B_1$  can transport GSM carriers between the gateway and the space-based component, band  $B_2$  can transport narrowband CDMA carriers and band  $B_3$  may transport wideband CDMA carriers. It will be understood by those having skill in the art that corresponding return feeder link bands may be provided for carriers from the space-based component **1610, 1710** to the gateway **1660, 1760**. In other embodiments of the present invention, an ancillary terrestrial network **1650, 1750** also may be provided to communicate terrestrially with radiotelephones **1620, 1720** in the satellite footprint. Thus, in some embodiments, the ancillary terrestrial network **1650, 1750** may provide a larger portion of the radiotelephone communications in urban areas, whereas the space-based component **1610, 1710** may provide a larger portion of the radiotelephone communications in rural areas.

Figure 13 is a block diagram of satellite radiotelephone systems and/or methods that can use multiple bands and/or multiple modes according to some embodiments of the present invention. It will be understood by those having skill in the art that Figure 13 relates to GSM, and system elements that provide a GSM air interface are shown. However, other satellite  
5 radiotelephone systems and/or methods also may be provided according to embodiments of the present invention.

In particular, as shown in Figure 13, these embodiments of satellite radiotelephone communication systems and methods include a space-based component **1310**, for example a geostationary satellite, and at least one Gateway Station System (GSS) **1360**, Network  
10 Operation Center (NOC) **1362**, Mobile Switching Center (MSC) **1364**, Base Station Controller (BSC) **1366** and Base Transceiver Station (BTS) **1368**. The satellite radiotelephone system may be connected to the Public Switched Telephone Network (PSTN) **1772** and/or to one or more Public Data Networks (PDN) **1774**. In addition, to offer a General Packet Radio Service (GPRS), some MSCs **1364** may be augmented by appropriate  
15 packet switching facilities, generally referred to as Support GPRS Service Node (SGSN) and GPRS Gateway Support Node (GGSN). The GSS also may be connected to a Tracking Telemetry & Command (TT&C) system **1776**. A plurality of radiotelephones **1320** also may be provided.

Figure 14 illustrates frequency reuse between a space-based component and an  
20 ancillary terrestrial network according to some embodiments of the present invention. As shown in Figure 14, relatively small ancillary terrestrial network cells **1450** are nested inside the relatively large satellite cells **1440**. This may occur because, even with large reflectors that may be used in the space-based component **1410**, the satellite cells **1440** may still be on the order of several hundred kilometers in diameter, whereas the ancillary terrestrial network  
25 cells **1450** may be two, three or more orders of magnitude smaller than the satellite cells. In Figure 14, terrestrial reuse of the same carrier frequency is indicated by the same symbol (, □ or \*).

Embodiments of the present invention as shown in Figures 13 and 14 can allow a single satellite radiotelephone system to support a plurality of ancillary terrestrial components  
30 **1452** in an ancillary terrestrial network **1450**, with at least some of the ancillary terrestrial components **1452** providing terrestrial connectivity via a different air interface. This may allow the relatively large satellite footprint **1430** to be used in a terrestrial market which is segmented. Thus, in some embodiments, the satellite radiotelephone system may be configured to support a GSM-based ancillary terrestrial component, a narrowband CDMA-

based ancillary terrestrial component, and a wideband CDMA-based ancillary terrestrial component, at the same time and over the same or different satellite cells. In other embodiments, a subset of the ancillary terrestrial components may be operating at L-band, for example, while another subset of ancillary terrestrial components may be operating at S-band.

5 As was already described, in some embodiments, satellite radiotelephone communications systems and methods can provide substantially the same band/same air interface service for both space-based communications with the space-based component and terrestrial communications with at least one of its ancillary terrestrial components. This can allow simplified radiotelephones.

10 In particular, Figure 15 is a block diagram of radiotelephones **1520** that may be used to communicate with a space-based component and an ancillary terrestrial component in satellite radiotelephone systems or methods according to some embodiments of the present invention. In some embodiments, these radiotelephones **1520** can be used with satellite radiotelephone systems according to some embodiments of the present invention that include  
15 an ancillary terrestrial component and a space-based component that use substantially the same band and substantially the same air interface. The ability to reuse the same spectrum for space-based and terrestrial communications can facilitate low cost, small and/or lightweight radiotelephones, according to some embodiments of the present invention.

Moreover, some embodiments of the present invention can place more of the burden  
20 of link performance with the space-based component rather than the radiotelephone, compared to prior satellite radiotelephone systems, such as Iridium or Globalstar. Accordingly, large antennas may not need to be used in the radiotelephone. Rather, antennas that are similar to conventional cellular radiotelephone antennas may be used.

Accordingly, referring to Figure 15, a single Radio Frequency (RF) chain including  
25 low pass filters **1522**, up and down converters **1524a**, **1524b**, Local Oscillators (LO) **1526**, Low Noise Amplifier (LNA) **1528**, Power Amplifier (PA) **1532**, bandpass filters **1534** and antenna **1536**, may be used. A single baseband processor **1542** may be used, including an analog-to-digital converter (A/D) **1544**, a digital-to-analog converter (D/A) **1546** and a Man-Machine Interface (MMI) **1548**. An optional Bluetooth interface **1552** may be provided. An  
30 Application-Specific Integrated Circuit (ASIC) **1554** may include thereon Random Access Memory (RAM) **1556**, Read-Only Memory (ROM) **1558**, a microprocessor ( $\mu$ P) **1562**, logic for ancillary terrestrial communications (ATC Logic) **1564** and logic for space-based communications (Space Segment Logic or SS Logic) **1566**. The SS Logic **1566** can be used to accommodate satellite-unique requirements over and above those of cellular or PCS, such

as a satellite-unique vocoder, a satellite forward error correction coding scheme, a satellite-unique interleaver, etc. However, this added gate count may not increase the cost of the ASIC **1554**.

According to other embodiments of the invention, the space-based component may be  
5 dimensioned appropriately, so that there is no need for radiotelephones to use large antennas  
**1536** or to have to radiate any more power when in satellite mode than when in terrestrial  
mode. An appropriate level of link robustness may be attained via the spot-beam gain that  
can be provided by a larger satellite antenna and/or other techniques. This can more than  
10 compensate for the several dB reduction in satellite link robustness that may occur when  
eliminating a large satellite antenna from the radiotelephone and/or using a single antenna for  
terrestrial and satellite communications. Accordingly, single mode and single band  
radiotelephones may be provided that can communicate with the space-based component and  
the ancillary terrestrial network over a single band and single air interface.

15 Aggregate Radiated Power Control for Multi-Band/Multi-Mode Satellite Radiotelephone  
Communications Systems and Methods

Multi-band/multi-mode satellite radiotelephone communications systems and methods  
according to other embodiments of the present invention now will be described.

In particular, referring to Figure 18, a satellite radiotelephone system includes a  
20 space-based component **1610** that is configured to communicate with a plurality of  
radiotelephones over a plurality of frequency bands and/or a plurality of air interfaces. The  
links that use the plurality of frequency bands and/or air interfaces are denoted in Figure 18  
as **1880a-1880f**, although it will be understood that fewer or more frequency bands/air  
interfaces may be used. An ancillary terrestrial network (ATN) **1850** is configured to  
25 communicate terrestrially with the plurality of radiotelephones over substantially the plurality  
of frequency bands and/or substantially the plurality of air interfaces. It will be understood  
that, in Figure 18, five ancillary terrestrial components (ATC) **1852a-1852f** are shown,  
although fewer or more ancillary terrestrial components may be employed in the ancillary  
terrestrial network **1850**. A satellite gateway **1660** and a PDN/PSTN **1810** are also provided  
30 as was already described.

Still referring to Figure 18, an aggregate radiated power controller **1820** is provided  
that is configured to limit an aggregate radiated power by the plurality of radiotelephones to a  
maximum aggregate radiated power. In some embodiments, the aggregate radiated power  
controller is configured to control a plurality of co-frequency radiotelephones, so as to limit

the aggregate radiated power by the plurality of co-frequency radiotelephones to a maximum aggregate radiated power. As used herein, "co-frequency" means that the radiotelephones use the same carrier frequency even if they use different TDMA time slots (different TDMA channels) or use different CDMA spreading codes (different CDMA channels). Accordingly, compliance with radiation requirements for the ancillary terrestrial network **1850** may be maintained even though the ancillary terrestrial network **1850** employs a plurality of frequency bands and/or air interfaces. It will be understood that the aggregate radiated power controller **1820** may be provided as a stand alone component, as part of the gateway **1660**, and/or as part of another component of the satellite radiotelephone system and/or the ATN.

In some embodiments of the present invention, the aggregate radiated power controller **1820** is configured to allow control over substantially all of the ATN and/or substantially all of the radiotelephones that are communicating therewith. However, in other embodiments of the present invention, the aggregate radiated power controller **1820** is configured to limit an aggregated radiated power by a subset of the plurality of radiotelephones to a maximum aggregate radiated power. For example, in some embodiments, the plurality of frequency bands comprises a first frequency band and a second frequency band, and the subset of the plurality of radiotelephones comprises radiotelephones that communicate terrestrially with the ancillary terrestrial network over substantially the first frequency band. In some embodiments, the first frequency band comprises L-band frequencies and, in some embodiments, the second frequency band comprises S-band frequencies. In other embodiments, the first frequency band comprises L-band frequencies that are used substantially inter-radio-horizon by another system and the second frequency band comprises L-band frequencies that are not used substantially inter-radio-horizon by another system. In these embodiments, the second frequency band may further comprise S-band frequencies.

Thus, in some embodiments, only a first subset of the ATN, and/or the radiotelephones communicating therewith, may be subject to aggregate radiated power control, whereas a second subset of the ATN, and/or the radiotelephones that are communicating therewith, need not be subject to aggregate radiated power control. For example, L-band frequencies that are radiated terrestrially may potentially cause interference with another system, and may be subject to aggregate radiated power control. In contrast, S-band frequencies and L-band frequencies that are not used substantially inter-radio-horizon by another system may not potentially cause interference with another system, and therefore

may not be subject to aggregate radiated power control, according to embodiments of the present invention.

More specifically, a Mobile Satellite System (MSS) including an ATN **1850** may provide voice and/or data services to end users over its footprint using more than one air interface protocol. It may be desirable for the system to be capable of providing services to end users via several air interface protocols given the current fragmentation and potential future uncertainty of the U.S. radiotelephone communications market. Currently, the U.S. market may be serviced by iDEN, GSM and cdma2000, but other emerging standards, such as W-CDMA and/or OFDM/OFDMA, may be used in the future. A system architecture that lends itself to the plurality of current standards (air interface protocols) and can also accommodate future (currently anticipated or not) technologies can offer increased flexibility.

Figure 18 illustrates a potential deployment scenario for the ATN. As shown, different and/or overlapping geographical areas may be served by ATCs **1852a-1852f** that are using different air interface protocols. The satellite **1610** is capable of transporting the plurality of protocols to/from the satellite gateway **1660** where different sets of transceiver units may be associated with the processing of the different air interface waveforms. The radiotelephone may contain an integrated transceiver capable of communicating via the satellite **1610** or via at least one ATC **1852**, and potentially over other PCS/cellular bands, depending, for example, on business relationships that may be established with other wireless operators. The satellite/ATN part of the radiotelephone transceiver may utilize substantially the same air interface protocol to communicate via the satellite **1610** or via at least one ATC **1852**. This approach can reduce or minimize the size, weight and/or manufacturing cost of the transceiver by increasing the level of integration and reuse of hardware and software for both satellite and ATN modes.

In some embodiments of the invention, the ATN may be based on a CDMA air interface protocol without producing any greater interference potential than the Federal Communications Commission rules allow for a GSM-based ATN. See, Report and Order and Notice of Proposed Rulemaking, FCC 03-15, *Flexibility for Delivery of Communications by Mobile Satellite Service Providers in the 2 GHz Band, the L-Band, and the 1.6/2.4 Bands*, IB Docket No. 01-185, Adopted: January 29, 2003, Released: February 10, 2003, hereinafter referred to as "FCC 03-15". Thus, the technology used by the ATN or any of its ATCs can be irrelevant as long as the aggregate co-frequency emissions level is controlled so as not to exceed the limit set forth by the Commission for the specific GSM system considered in FCC 03-15. As such, an ATN **1850** can be developed to function with a plurality of air interface

protocols simultaneously, as long as it adheres to the aggregate radiated power spectral density limit set forth by the Commission (i.e.,  $-53 + 10\log(1,725)$  dBW/Hz).

In FCC 03-15, the Commission allowed 1,725-fold terrestrial reuse, by the US ATN, of a GSM carrier that is also used by the MSS for satellite communications. A single fully-  
5 loaded GSM carrier on an ATC return link, which is being radiated from several radiotelephones (up to eight) to a base station, may launch a maximum -53 dBW/Hz of power spectral density into space. The maximum aggregate power spectral density that may be launched into space from 1,725 co-channel fully loaded return-link GSM carriers is, therefore,  $-53 + 10\log(1725) \approx -20.64$  dBW/Hz. This is based on a GSM radiotelephone  
10 peak EIRP of 0 dBW, consistent with the analysis of FCC 03-15. It is this maximum aggregate power spectral density, produced on the return link by the maximum allowed US-wide frequency reuse of the ATN, that the Commission has concluded may potentially raise the noise floor of Inmarsat's satellite receivers by as much as 0.7%.

The maximum EIRP of a CDMA return link code (user) may be -10 dBW and may be  
15 transmitted over a carrier occupying a bandwidth of 1.25 MHz in accordance, for example, with the cdma2000 air interface standard. Thus,  $-10 - 10\log(1,250,000) \approx -70.97$  dBW/Hz of power spectral density may be launched into space by a single CDMA code (user) operating on an ATC return link. The allowed -20.64 dBW/Hz maximum aggregate power spectral density limit, as derived above, may therefore accommodate approximately  
20  $10^{[(70.97 - 20.64)/10]} \approx 107,894$  co-channel return link CDMA codes. This result may be used to establish an equivalence relation, for the ATN return link, between a pure GSM ATN and a pure CDMA ATN.

Thus, from an aggregate return link interference power spectral density standpoint, 1,725-fold US-wide frequency reuse of a GSM carrier by the ATN may be considered  
25 equivalent to approximately 107,894 codes (users) transmitting US-wide on a given 1.25 MHz CDMA carrier. The number of users is generally less than or equal to the number of codes, because a user may be allocated more than one code to improve the reliability and/or data rate of transmission. The stated equivalence is based on GSM's peak return link EIRP assumed to be 0 dBW while that of a CDMA code is assumed to be -10 dBW.

30 A mathematical equivalence may be established between a single active (transmitting) GSM time slot (user) transmitting at a peak EIRP of 0 dBW, and a number of CDMA codes (users) being active and each transmitting at a peak EIRP of -10 dBW. This relationship can allow deploying an ATN that contains both GSM and CDMA technologies, and potentially fluctuating capacity between the two, and is, from the point of view of aggregate return link

interference power spectral density potential, equivalent to the pure GSM system that the Commission addressed in FCC 03-15.

In particular, according to FCC 03-15, there are  $1,725 \times 8 = 13,800$  GSM time slots (users) that can be active on the ATN (US-wide) on a given GSM carrier while maintaining the potential for noise increase to Inmarsat's satellite receivers at 0.7%. It was shown above that, from an aggregate up-link power spectral density interference potential standpoint, this is equivalent to approximately 107,894 codes (users) transmitting on a given 1.25 MHz CDMA carrier (US-wide). Thus, one active co-frequency GSM slot (user) equates to approximately  $107,894/13,800 \approx 7.8184$  active co-frequency CDMA codes (users). Thus, an equation that may be used to govern co-frequency ATN operations over the United States may be:

$$N_{\text{GSM}} + 13,800N_{\text{CDMA}}/107,894 = 13,800. \quad (1)$$

In Equation (1),  $N_{\text{GSM}}$  denotes the number of active co-frequency GSM time slots (users) while  $N_{\text{CDMA}}$  denotes the number of active co-frequency CDMA codes (users). In some embodiments, the  $N_{\text{GSM}}$  GSM time slots are at least partially co-frequency with the  $N_{\text{CDMA}}$  CDMA codes. Since there are 6 distinct GSM carriers that can be co-frequency with a single CDMA carrier of 1.25 MHz bandwidth, the co-frequency CDMA carrier loading will deplete, by the same amount of  $13,800N_{\text{CDMA}}/107,894$ , the US-wide capacity of all 6 corresponding (co-frequency with the CDMA carrier) GSM carriers. Based on the above, it is seen that a US-wide ATN network that is configured to support simultaneously both GSM and cdma2000 traffic can be compliant with the Commission's uplink interference constraint (no more than 0.7%  $\Delta T/T$  impact to, for example, Inmarsat) if and only if Equation (1) is substantially satisfied. The MSS/ATN operator may comply by apportioning the total co-frequency traffic in such an ATN substantially in accordance with Equation (1).

As discussed earlier, a fully-loaded GSM return link carrier (all eight time slots occupied) may generate -53 dBW/Hz of maximum EIRP density potential. This result is based on GSM radiotelephones/radioterminals having an antenna gain of, for example, 0 dBi and radiating a maximum 0 dBW EIRP over a carrier bandwidth of 200 kHz (in accordance with the FCC's assumptions in FCC 03-15).

A cdma2000 ATN radioterminal having, for example, a 0 dBi antenna gain may be limited (by design) to a maximum of, for example, -9 dBW EIRP while communicating using a single code. Given the 1.25 MHz carrier bandwidth of cdma2000 (1xRTT) the maximum EIRP density that may be generated by a single cdma2000 return-link code may be

$-9 -10\log(1.25 \times 10^6) \approx -70$  dBW/Hz. It therefore follows that  $10^{[(70-53)/10]} \approx 50$  co-frequency cdma2000 codes may generate the same uplink interference power spectral density potential as one fully-loaded GSM carrier.

For W-CDMA, an ATN radioterminal having, for example, a 0 dBi antenna gain may be limited (by design) to a maximum of, for example, -9 dBW EIRP while communicating using a single code. Given the 5 MHz carrier bandwidth of W-CDMA, such a radioterminal may generate an EIRP density potential of  $-9 -10\log(5 \times 10^6) \approx -76$  dBW/Hz. Thus,  $10^{[(76-53)/10]} \approx 200$  co-frequency W-CDMA codes may generate the same uplink interference power spectral density potential as one fully-loaded GSM carrier.

For an ATN that may be based on all three technologies (GSM, cdma2000, and W-CDMA) the following constraint equation may be used to specify the allowed distribution of on-the-air co-frequency traffic associated with the three standards:

$$N/8 + M/50 + L/200 = R \quad (2)$$

where N denotes the number of GSM time slots (channels) supported ATN-wide co-frequency by a given GSM carrier as that carrier is used and reused, M represents the number of cdma2000 co-frequency codes (channels) supported by a single cdma2000 carrier as that carrier is used and reused throughout the ATN, L identifies the number of W-CDMA co-frequency codes (channels) on a single W-CDMA carrier as that carrier is used and reused by the ATN, and R denotes the pure GSM-based ATN frequency reuse authorized by the FCC. In some embodiments, the N GSM time slots, the M cdma2000 codes and the L W-CDMA codes are at least partially co-frequency. Note that the above equation can provide a constraint that may be imposed on co-frequency operating carriers (all three carrier types, GSM, cdma2000, and W-CDMA, whose ATN-wide traffic is apportioned in accordance with the above equation may be operating co-frequency). Furthermore, for a pure GSM-based ATN deployment, the above equation reduces to  $N = 8R$  ( $M = L = 0$ ) which confirms that the total number of time slots (channels) that can be supported by a single GSM carrier ATN-wide equals eight times the authorized frequency reuse.

Since there are 6 GSM carriers that may fit within the bandwidth occupied by a single cdma2000 carrier, the nationwide loading (M) of a cdma2000 carrier may deplete, by the same amount of  $M/50$ , the nationwide capacity of all 6 corresponding (co-frequency with the cdma2000 carrier) GSM carriers. Similarly, since there are 25 GSM carriers that may exist within the bandwidth occupied by a single W-CDMA carrier, the nationwide loading (L) of a W-CDMA carrier may deplete, by the same amount of  $L/200$ , the nationwide capacity of all

25 corresponding (co-frequency with the W-CDMA carrier) GSM carriers. For similar reasons, since there are 4 cdma2000 carriers that may be accommodated (co-frequency) over the band of frequencies occupied by a W-CDMA carrier, the nationwide loading of a W-CDMA carrier may deplete, by the same amount of  $L/4$ , the nationwide capacity of all 4  
 5 corresponding (co-frequency with the W-CDMA carrier) cdma2000 carriers.

Equations (1) and (2) may be generalized as follows:

$$\sum_{i=1}^x \frac{N_i}{F_i} = \text{MARF}, \quad (3)$$

where  $N_i$  is the number of co-frequency active users using a given frequency band and/or air interface  $i$ ;

10  $F_i$  is a corresponding equivalence factor (which may be less than, greater than or equal to 1) for the given frequency band/air interface  $i$ ; and

MARF is a measure of the maximum aggregate radiated power spectral density that is permitted.

It will be understood that in FCC 03-15, the aggregate radiated Power Spectral  
 15 Density (PSD) that may be launched U.S.-wide by radioterminals communicating with an ATN may not exceed  $-53 + 10\log(1725) \approx -20.6$  dBW/Hz. In arriving at this conclusion the FCC assumed that the ATN will be based on GSM technology and that the GSM radioterminals will be capable of launching in the direction of a co-frequency satellite system (e.g., Inmarsat) a maximum (uplink) EIRP of 0 dBW per carrier. The FCC's conclusion is  
 20 also based on the assumption that only 50% of the ATN is inside the U.S.

The aggregate radiated U.S.-wide PSD may be higher if more than 50% of the ATN is allowed to be inside the U.S. For example, based on 80% deployment of the total ATN inside the US, the aggregate allowed US-wide PSD potential may grow to  $-53 + 10\log(2760) \approx -18.6$  dBW/Hz. In FCC 03-15, the Commission concluded that the aggregate average  
 25 signal attenuation that is relevant to uplink interference is 242.7 dB. This number takes into account attenuation/suppression of the interfering signal(s) due to (a) free-space propagation (188.7 dB), (b) co-frequency system satellite antenna discrimination in the direction of the ATN (25 dB), (c) outdoor blockage (3.1 dB), (d) closed-loop power control implemented by the ATN (20 dB), (e) use of a lower-rate vocoder (3.5 dB), (f) voice activity (1 dB), and (g)  
 30 polarization discrimination provided by the co-frequency satellite system (1.4 dB). (See FCC 03-15, Appendix C2, Table 2.1.1.C, page 206). The interference signal suppression due to power control (20 dB) comprises 2 dB due to "range taper" and 18 dB due to structural attenuation. Based on the Commission's conclusions/assumptions, as specified in FCC 03-

15, and assuming deployment of up to 80% of the ATN inside the US, the aggregate average PSD potential at the input of a co-frequency satellite antenna may be limited to  $-18.6 - 242.7 = -261.3$  dBW/Hz.

As was described above, aggregated radiated power controlling systems and methods according to some embodiments of the present invention, may be configured to limit an aggregate radiated power by a plurality of radiotelephones to a maximum aggregate radiated power. In embodiments that were described above, it was assumed that the ATN has the same amount of structural attenuation margin and/or return link margin across all ancillary terrestrial components thereof, that use a given frequency band and/or carrier frequency and/or air interface. The calculations that were described above were made under this assumption. However, this may not always be the case. Rather, according to other embodiments of the present invention, various ATCs in the ATN may provide different structural attenuation and/or return link margins. In fact, according to other embodiments of the present invention, link margins may be increased in various ATCs, to allow larger numbers of radioterminals to communicate terrestrially without exceeding a maximum aggregate radiated power. Two illustrative examples will be provided. In a first example, a plurality of cdma2000 radioterminals communicate with ATN infrastructure that provides 18 dB of structural attenuation margin. In a second example, not all of the ATN infrastructure provides 18 dB of structural attenuation margin.

Thus, in the first example, all cdma2000 ATC radioterminals communicate with infrastructure that provides 18 dB of structural attenuation margin. Relative to a satellite, a cdma2000 ATN radioterminal may radiate, for example, a maximum (spatially averaged) EIRP of -13 dBW per communications channel (i.e., per code; the EIRP consumed by the pilot channel is neglected for the sake of simplicity). Hence, the radioterminal's PSD potential, per communications channel, may be  $-74$  dBW/Hz (at the radioterminal's antenna output) and  $-74 - 242.7 = -316.7$  dBW/Hz at the satellite's antenna input. The number of such radioterminals (communications channels) that operate co-frequency in order to generate the allowed PSD potential of  $-261.3$  dBW/Hz, at the input of a satellite antenna, is  $10^{[(316.7 - 261.3)/10]} = 346,736$ . In some embodiments, up to seven (7) cdma2000 carriers may be deployed in the ATN. Thus, the total on-the-air capacity of a U.S.-based ATN may be  $346,736 \times 7 = 2,427,152$  simultaneous communications channels.

In the second example, not all radioterminals are communicating with infrastructure that provides 18 dB of structural attenuation margin. For example, let X, Y, and Z denote US-wide potential percentages (%) of ATN cdma2000 radioterminals that may be

communicating co-frequency with ATN infrastructure that is providing A, B, and C dB, respectively, of structural attenuation margin. Thus:

$$X + Y + Z = 100. \quad (4)$$

5

Letting L, M, and N denote the number of potential radioterminals that may be communicating with class A, B, and C infrastructure, respectively, we may write:

$$X = 100L/(L + M + N), Y = 100M/(L + M + N), Z = 100N/(L + M + N). \quad (5)$$

10

Subject to the three classes/categories of ATN infrastructure (as defined above) that may be serving the ATN radioterminals, the aggregate power spectral density potential (in Watts/Hz) at a satellite antenna input may be:

$$\text{psd} = [L\xi + M\zeta + N\varsigma]\sigma^2 \text{ Watts/Hz}. \quad (6)$$

15

In Equation (6), the quantity  $10\log(\sigma^2)$  may, for example, be specified as -74 dBW/Hz, and  $\xi$ ,  $\zeta$ , and  $\varsigma$ , may denote average aggregate (power-domain) attenuation factors associated with the three classes of radioterminals that may be served by the three classes of infrastructure, respectively. Thus, we may write:

20

$$10\log(\xi) = -(188.7 + 25 + 3.1 + (A + 2) + 3.5 + 1 + 1.4) = -(224.7 + A) \text{ dB} \quad (7)$$

$$10\log(\zeta) = -(188.7 + 25 + 3.1 + (B + 2) + 3.5 + 1 + 1.4) = -(224.7 + B) \text{ dB}; \text{ and} \quad (8)$$

$$10\log(\varsigma) = -(188.7 + 25 + 3.1 + (C + 2) + 3.5 + 1 + 1.4) = -(224.7 + C) \text{ dB}. \quad (9)$$

25

Using Equation (5):

$$N = L[(100-X)(100-Y) - XY]/100X, \text{ and } M = 100YL/[(100-Y)(100-Z) - YZ]. \quad (10)$$

30 Substituting Equations (7) through (10) into Equation (6) and taking the logarithm, the average PSD potential at a victim satellite may be expressed as:

$$\text{PSD} \equiv 10\log(\text{psd}) = 10\log(\sigma^2) + 10\log(L)$$

$$\begin{aligned}
 &+ 10\log(10^{-(22.47 + 0.1A)} + 10^{-(22.47 + 0.1B)} \times 100Y/[(100-Y)(100-Z) - YZ] \\
 &+ 10^{-(22.47 + 0.1C)} \times [(100-X)(100-Y) - XY]/100X)
 \end{aligned} \tag{11}$$

or,

5

$$\begin{aligned}
 &-261.3 = -74 + 10\log(L) \\
 &+ 10\log(10^{-(22.47 + 0.1A)} + 10^{-(22.47 + 0.1B)} \times 100Y/[(100-Y)(100-Z) - YZ] \\
 &+ 10^{-(22.47 + 0.1C)} \times [(100-X)(100-Y) - XY]/100X).
 \end{aligned} \tag{12}$$

10 Solving for L:

$$L = 10^{-18.73 - \log(\quad)} \tag{13}$$

15 In Equation 13, the second term of the exponent “log( )” is defined by Equation (12). That is:

$$\begin{aligned}
 \log(\quad) \equiv &\log(10^{-(22.47 + 0.1A)} + 10^{-(22.47 + 0.1B)} \times 100Y/[(100-Y)(100-Z) - YZ] \\
 &+ 10^{-(22.47 + 0.1C)} \times [(100-X)(100-Y) - XY]/100X).
 \end{aligned} \tag{14}$$

20 Once L is found from Equation (13), N and M may be evaluated using Equations (5) as follows:

$$N = L[(100 - X)(100 - Y) - XY]/100X, \text{ and } M = Y(L + N)/(100 - Y) \tag{15}$$

25 The following Table provides illustrative numerical results:

Table

X(%)/ A(dB)	Y(%)/ B(dB)	Z(%)/ C(dB)	L	M	N	L+M+N	(L+M+N)x7
100/18	0/18	0/18	346,736	0	0	346,736	2,427,152
60/22	30/12	10/6	68,859	34,439	11,499	114,797	803,579
30/18	60/12	10/6	24,349	48,685	8,108	81,142	567,994

Accordingly, the second example that was described above may provide additional embodiments of Equation (3), wherein  $N_i$  denotes a number of co-frequency channels that are operative subject to a common ( $i^{\text{th}}$ ) structural attenuation margin for a given frequency band and/or carrier frequency and/or air interface,  $F_i$  denotes a corresponding equivalence factor, which may be less than, greater than, or equal to 1, for the common ( $i^{\text{th}}$ ) structural attenuation margin for the given frequency band/carrier frequency/air interface, and MARP is a measure of the maximum aggregated radiated power, i.e., the maximum aggregate radiated Power Spectral Density (PSD).

In some embodiments of the invention, an ATN may be configured to maintain a list of infrastructure components (i.e., base stations and/or base station groupings), and associate with each infrastructure component a measure of Structural Attenuation Margin (SAM). Based on the registration procedure of radioterminals, and/or other means, the ATN may also be configured to have knowledge of the infrastructure component with which each active (on-the-air) radiotermlinal is communicating. Thus, the ATN may be configured to associate a SAM with each active radiotermlinal and may thus be configured to evaluate the quantity  $\Sigma_i(\text{psd})_i$ , where  $\text{psd}$  denotes a power spectral density at a satellite and where the summation may be performed over an ensemble of active (on-the-air) radiotermlinals that are operating co-frequency in the ATN (i.e., are sharing in whole or in part an ATN band and/or sub-band of frequencies). In some embodiments of the invention, the quantity  $(\text{psd})_i$  may be evaluated for the  $i^{\text{th}}$  co-frequency radiotermlinal as:

$$(\text{psd})_i = 10^{\lceil \log(p_i/BW_i) + \log(\alpha_i) \rceil}, \quad (16)$$

where the quantity  $10\log(p_i)$  may denote a measure of the maximum EIRP in the direction of a satellite that may be generated by the  $i^{\text{th}}$  active (on-the-air) radiotermlinal (e.g., -4 dBW for GSM, -13 dBW for cdma2000 and/or W-CDMA),  $BW_i$  may denote a measure of the bandwidth occupied by the carrier being radiated by the  $i^{\text{th}}$  active radiotermlinal (e.g., 200 kHz for GSM, 1.25 MHz for cdma2000, and 5 MHz for W-CDMA), and  $10\log(\alpha_i)$  may denote a measure of aggregate signal attenuation that may exist between the  $i^{\text{th}}$  radiotermlinal and a satellite.

The quantity  $10\log(\alpha_i)$  may further be expressed as  $10\log(\alpha_i) = -(L + \text{SAM}_i)$  dB, where  $L$  is defined as a measure of aggregate signal attenuation potential comprising, for example, (a) free-space propagation (i.e., 188.7 dB), (b) co-frequency satellite antenna discrimination (i.e., 25 dB), (c) outdoor blockage (i.e., 3.1 dB), (d) ATN power control due to

range taper (i.e., 2 dB), (e) effect of low-rate vocoder (i.e., 3.5 dB), (f) effect of voice activity (i.e., 1 dB), and (g) polarization discrimination provided by co-frequency satellite antenna (i.e., 1.4 dB). (See FCC 03-15 Appendix C2, Table 2.1.1.C; page 206). SAM<sub>i</sub> may denote a measure of structural attenuation margin provided by the infrastructure component (i.e., a  
 5 base station and/or a group of base stations) with which the i<sup>th</sup> active co-frequency radioterminal is communicating. Typical values of SAM<sub>i</sub> may be, for example, 22 dB, 18 dB, 12 dB, and 6 dB, for dense-urban, urban, sub-urban, and rural infrastructure components, respectively.

Accordingly, in some embodiments of the present invention, the aggregate radiated  
 10 power controller is configured to control a plurality of co-frequency radioterminals, so as to limit the aggregate radiated power by the plurality of radioterminals to a maximum aggregate radiated power according to:

$$\sum_{i=1}^x (\text{psd})_i = \text{MARP}, \quad (17)$$

15

where (psd)<sub>i</sub> is a measure of radiated power spectral density at a satellite and MARP is a measure of allowed maximum aggregate radiated power. In some embodiments, psd is determined according to  $(\text{psd})_i = 10^{[\log(p_i/BW_i) + \log(\alpha_i)]}$ , where  $10\log(p_i)$  denotes a measure of maximum radiated power by the i<sup>th</sup> radioterminal in a direction of a satellite, BW<sub>i</sub> denotes a  
 20 bandwidth occupied by a carrier that is radiated by the i<sup>th</sup> radioterminal and  $10\log(\alpha_i)$  denotes a measure of signal attenuation (in dB) between the i<sup>th</sup> radioterminal and the satellite.

The ATN may evaluate the quantity  $\sum_i (\text{psd})_i$ , and/or another measure thereof, as needed, and may, in response to the value of  $\sum_i (\text{psd})_i$ , and/or the value of the other measure, approaching, being equal to, or having exceeded a threshold value, control the ancillary  
 25 terrestrial network and/or one or more of the radioterminals to limit the aggregate radiated power to a maximum aggregate radiated power.

Many techniques may be used to limit the aggregate radiated power. For example, in some embodiments, one or more co-frequency radioterminals may be commanded to 1) utilize a lower-rate vocoder, and/or 2) to reduce the rate of information transmission, and/or  
 30 3) to use other available ATN or non-ATN resources that may not be co-frequency with the resources that are relevant to the quantity  $\sum_i (\text{psd})_i$  (i.e., a frequency that has not exceeded the maximum aggregate radiated power) and/or another measure thereof. Thus, in some embodiments, the aggregate radiated power controller is configured to control the plurality of

radioterminals by reducing a vocoder rate of at least one of the radioterminals, and/or  
reducing a rate of information transmission of at least one of the radioterminals, and/or  
controlling at least one of the radioterminals to communicate using a frequency that has not  
exceeded the maximum aggregate radiated power, so as to limit an aggregate radiated power  
5 by the plurality of co-frequency radiotelephones to the maximum aggregate radiated power.

Many different techniques also may be used to determine which radioterminal and/or  
which portion of the ancillary terrestrial network to control to reduce the aggregate radiated  
power, according to various embodiments of the present invention. Thus, in some  
embodiments, at least one radioterminal is selected and controlled as described above, so as  
10 to reduce the aggregate radiated power. In other embodiments, at least one radioterminal that  
is subject to a low, and in some embodiments a lowest, structural attenuation margin and  
which is, therefore, radiating at a relatively high level, may be controlled according to any of  
the embodiments described above.

Moreover, in other embodiments, a radioterminal may be selected based on the  
15 frequency band and/or carrier frequency and/or air interface that it is using, so that if a given  
frequency band and/or carrier frequency and/or air interface exceeds a desired maximum  
aggregate radiated power, one or more radioterminals that is/are using that frequency band  
and/or carrier frequency and/or air interface may be controlled. Accordingly, in some  
embodiments, the aggregate radiated power controller is configured to control a plurality of  
20 radioterminals, by controlling at least one radioterminal that is communicating with the ATN  
over a frequency band and/or carrier frequency and/or air interface that has exceeded a  
maximum aggregated radiated power for that frequency band and/or carrier frequency and/or  
air interface, so as to limit the aggregate radiated power by the plurality of radioterminals for  
the frequency band and/or carrier frequency and/or air interface to a maximum aggregate  
25 radiated power for the frequency band and/or carrier frequency and/or air interface. *A priori*  
radiated power quotas for a given frequency band and/or carrier frequency and/or air interface  
thereby may be observed.

In yet other embodiments of the invention, the aggregate radiated power controller is  
configured to control the ancillary terrestrial network itself, i.e., the terrestrial infrastructure,  
30 to thereby reduce the radiated power by at least one radioterminal. In particular, in some  
embodiments, the aggregate radiated power controller is configured to diversity combine  
signals that are received from at least one radioterminal by at least two ancillary terrestrial  
components and/or by an ancillary terrestrial component and at least one auxiliary antenna  
system, to thereby reduce the radiated power by the at least one radioterminal. The link

margin and/or structural attenuation margin of ATN infrastructure components may thereby be increased.

More specifically, according to the Commission's analysis of the interference potential to co-channel satellite systems by the ATN, the structural attenuation margin provided by an ATN infrastructure component on the return link(s) may be increased or maximized. Increasing or maximizing this parameter may have a direct impact on the frequency reuse and/or the number of co-frequency communications channels allowed by the ATN. For a given maximum EIRP of an ATN radioterminal, the margin available by an infrastructure component on a return link may be increased according to some embodiments of the invention, by increasing the number of receive antenna elements on the ATN tower(s) of the infrastructure component and/or by configuring at least some of the receive antenna elements to operate on multiple spatially-orthogonal dimensions. This approach may yield an infrastructure component able to provide  $\Phi$  dB of structural attenuation margin on forward links and  $\Psi$  dB of structural attenuation margin on return links, where  $\Psi \geq \Phi$ . In the limit as  $\Psi \rightarrow \infty$ , the radioterminal EIRP approaches zero and so does the interference potential to a co-frequency satellite receiver. As such, the frequency reuse and/or the number of co-frequency communications channels allowed by the ATN may be increased.

Figure 19 is a schematic diagram of systems and methods according to embodiments of the present invention, wherein the aggregate radiated power controller of Figure 18 is configured to control an ancillary terrestrial network of Figure 19 to diversity combine signals that are received from at least one radioterminal by at least two ancillary terrestrial components and/or by an ancillary terrestrial component and at least one auxiliary antenna system, to thereby reduce the radiated power by the at least one radioterminal. Moreover, according to other embodiments of the present invention, embodiments of Figure 19 may be used to increase link margin in a satellite radioterminal system that includes an ATN, independent of an aggregate radiated power controller.

Referring now to Figure 19, an ancillary terrestrial network 1850 includes a plurality of ancillary terrestrial components, shown in Figure 19 as first and second ancillary terrestrial components 1900a, 1900b, each of which communicates with at least one radioterminal 1930 over an area that defines a respective cell 1920a, 1920b.

Still referring to Figure 19, a tower of the first ATC 1900a is configured with one or more transmit antennas and/or one or more receive antennas. As stated earlier, at least some elements comprising the transmitter and/or receiver antenna(s) of the infrastructure

component may be operative in more than one spatial dimension. Moreover, a tower of the second ATC **1900b** may be configured with one or more transmit antennas and/or one or more receive antennas with at least some of the antenna elements thereof operative in more than one spatial dimension. The first ATC **1900a** and the second ATC **1900b** comprising the illustrative infrastructure component of Figure 19, may be adjacent ATCs. Each ATC of an ensemble of ATCs that may comprise an infrastructure component may have an associated cell **1920a**, **1920b**, that defines a cell edge inside of which the ATC is configured to serve at least one radioterminal **1930**. A radioterminal that may be proximate to the cell boundaries/edges of at least two adjacent ATCs, as illustrated in Figure 19, may be served concurrently by at least two adjacent ATCs **1900a**, **1900b**.

Accordingly, an infrastructure component comprising at least two adjacent ATCs, as illustrated in Figure 19, may be configured to utilize one or more antenna elements per ATC to receive and process the transmissions of the radioterminal, which can increase return link robustness and/or available return link margin. For example, as shown in Figure 19, a base station processor **1930** of the second base station **1900b** may be configured to forward transmissions that are received at the second base station **1900b** from radioterminal **1930** to a diversity receiver **1902** at the first base station **1900a** via a terrestrial wired and/or wireless link **1940**. The diversity receiver also may be located, at least in part, outside the first base station **1900a**. The diversity receiver **1902** may be used to combine the signals that are received at the second base station **1900b** and the signals that are received at the base station **1900a** from radioterminal **1930**, to thereby increase the return link robustness and/or the available return link margin. As such, the available return link margin and/or structural attenuation margin provided by the infrastructure component may be increased, facilitating, via closed-loop power control of the radioterminal by the infrastructure component, a reduction in output power by the radioterminal, thereby reducing the potential of interference to a co-frequency system such as a co-frequency satellite system.

To increase or further increase the available return-link margin and/or return-link structural attenuation margin that may be provided by an infrastructure component, according to other embodiments of the present invention, at least one additional auxiliary antenna system **1910a-1910d** may be disposed in the area/space between the cell edge and the base station tower of at least one ATC comprising the infrastructure component. Figure 19 illustrates an infrastructure component configuration comprising two auxiliary antenna systems per ATC of the infrastructure component. However, greater or fewer auxiliary antenna systems **1910a-1910d** may be used.

Still referring to Figure 19, a diversity receiver **1902** may be configured to accept and process signals derived from the antenna systems of the first ATC **1900a**, auxiliary antenna system **1910a**, auxiliary antenna system **1910b**, and from a base station processor **1930** associated with the second ATC **1900b**. The signals derived from the auxiliary antenna systems **1910a** and/or **1910b** and/or from the antenna system of ATC tower **1900a** may be sent to the diversity receiver **1902** via physical connection(s) and/or wirelessly. Similarly, the signals derived from the auxiliary antenna systems **1910c** and/or **1910d** and/or from the antenna system of ATC tower **1900b** may be sent to the base station processor **1930** via physical connection(s) and/or wirelessly.

The base station processor **1930** may also comprise a diversity receiver. The diversity receiver **1902** and/or base station processor **1930** may be configured to combine signals in accordance with any conventional optimum and/or sub-optimum performance index such as, for example, maximal ratio combining. The auxiliary antenna system(s) **1910a-1910d** may be configured to receive and/or transmit to/from radioterminals **1930**. Embodiments where the auxiliary antenna system(s) is/are configured to transmit to radioterminals may increase the available forward-link margin and/or the forward-link structural attenuation margin of the infrastructure component.

Accordingly, a first ancillary terrestrial component for a satellite radioterminal system according to some embodiments of the present invention includes a subsystem, such as a base station tower **1900a** that is configured to communicate terrestrially with a plurality of radioterminals **1930** over substantially the same frequency bands and/or air interfaces as the radioterminals communicate with a space-based component. A diversity receiver, such as diversity receiver **1902**, is configured to diversity combine signals from a radiotelephone **1930** that are received by the first ancillary terrestrial component **1900a** and/or by at least a second ancillary terrestrial component **1900b**, and/or by an auxiliary antenna system **1910**. The auxiliary antenna system may be located in the first cell **1920a**, such as auxiliary antenna systems **1910a**, **1910b**, or may be included outside the cell, such as auxiliary antenna systems **1910c**, **1910d**. These embodiments may also be used to increase link margin, independent of control by an aggregate radiated power controller.

In conclusion, an ancillary terrestrial network can communicate terrestrially with a plurality of radioterminals over a plurality of frequency bands and/or a plurality of air interfaces, while the aggregate radiated power and/or power spectral density, over any predetermined band of frequencies, may be limited to a predefined maximum.

In the drawings and specification, there have been disclosed embodiments of the invention and, although specific terms are employed, they are used in a generic and descriptive sense only and not for purposes of limitation, the scope of the invention being set forth in the following claims.

**What is claimed is:**

1. A method of controlling a cellular communications system, the method comprising:
  - identifying a power level to be used by a wireless transmitter of the cellular communications system, the wireless transmitter configured to transmit over a set of frequencies that is assigned to a given cell of the cellular communications system in a band of frequencies that is assigned to the cellular communications system;
  - determining a subset of frequencies in the set of frequencies that is assigned to the given cell, the subset of frequencies to be assigned to the wireless transmitter responsive to the identified power level to be used by the wireless transmitter;
  - assigning the subset of frequencies in the set of frequencies that is assigned to the given cell to the wireless transmitter for transmission at the identified power level; and
  - wherein the set of frequencies that is assigned to the given cell of the cellular communications system is in a satellite band of frequencies.
2. The method according to claim 1 wherein the wireless transmitter is a wireless transceiver and wherein the determining is further responsive to a detection of a signal from the wireless transceiver.
3. The method according to claim 2 wherein the detection is performed by a base station serving the wireless transmitter.
4. The method according to claim 1 wherein the determining is further responsive to a distance of the wireless transmitter from a base station serving the wireless transmitter.
5. The method according to any one of claims 1 to 4 further comprising: transmitting by the wireless transmitter over at least one frequency in the subset of frequencies that was assigned, at the identified power level.
6. A cellular communications system comprising:
  - a wireless transmitter that is configured to transmit over a set of frequencies that is assigned to a given cell of the cellular communications system in a band of frequencies that is assigned to the cellular communications system;
  - a controller that is configured to identify a power level to be used by the wireless transmitter and to determine a subset of frequencies in the set of frequencies that is assigned

to the given cell of the cellular communications system, the subset of frequencies to be assigned to the wireless transmitter responsive to the power level that was identified; and wherein the set of frequencies that is assigned to the given cell of the cellular communications system is in a satellite band of frequencies.

7. The system according to claim 6 wherein the wireless transmitter is a wireless transceiver and wherein the controller is further configured to determine the subset of frequencies responsive to a detection of a signal from the wireless transceiver.
8. The system according to claim 7 wherein the detection is performed by a base station serving the wireless transmitter.
9. The system according to claim 6 wherein the controller is further configured to determine the subset of frequencies responsive to a distance of the wireless transmitter from a base station serving the wireless transmitter.
10. The system according to any one of claims 6 to 9 wherein the wireless transmitter is further configured to transmit over at least one frequency in the subset of frequencies that was assigned, at the power level that was identified.

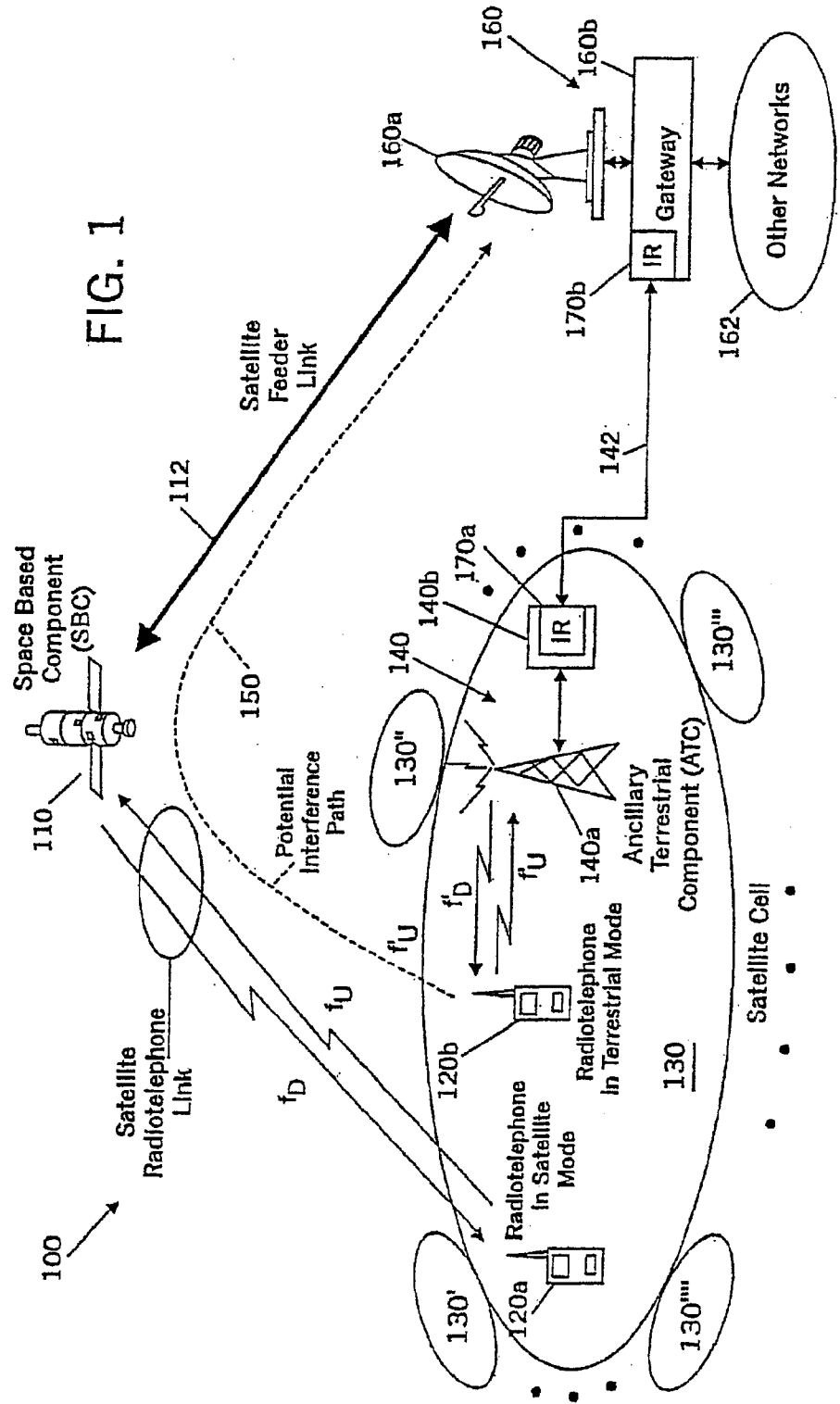
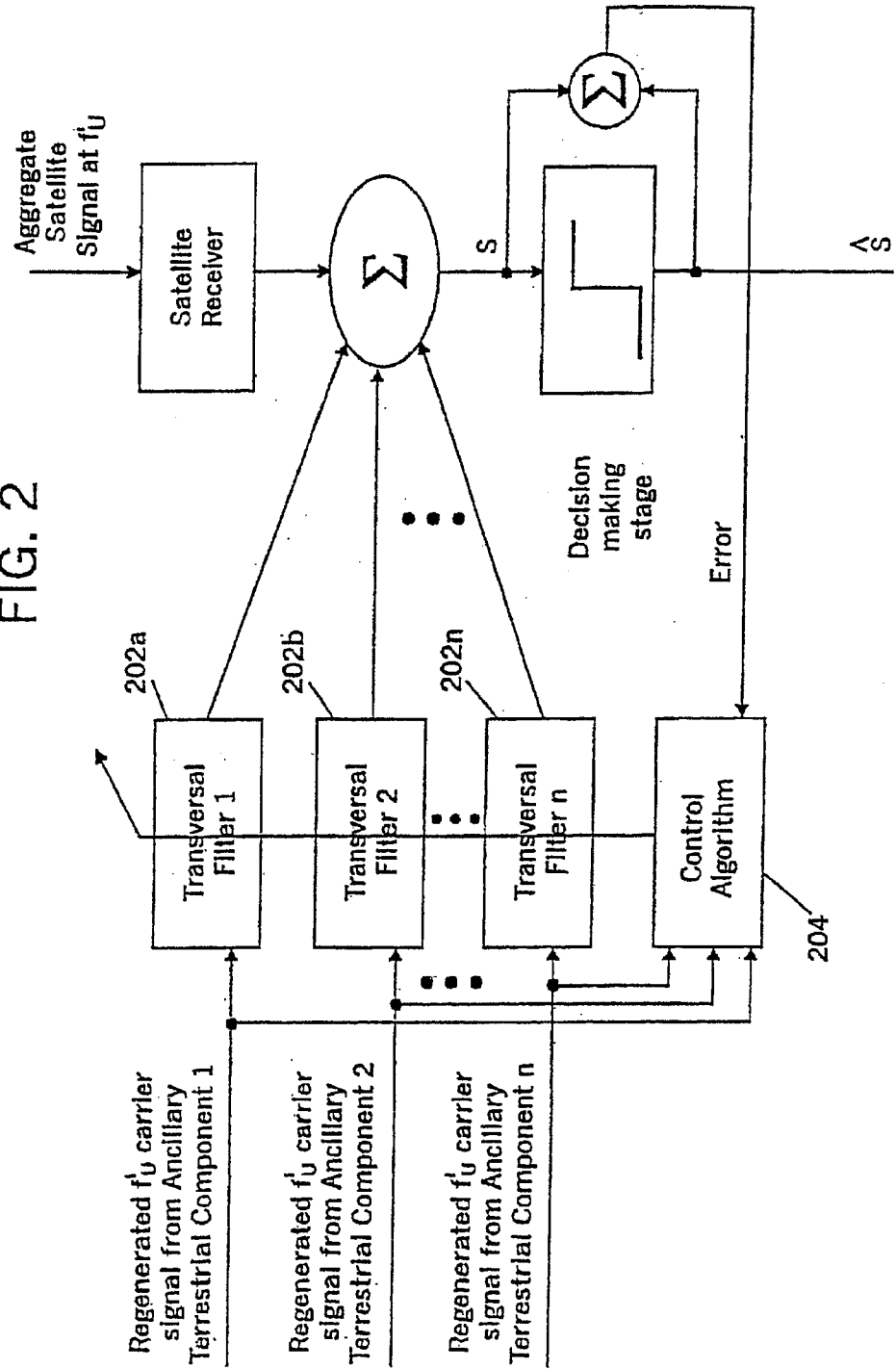

FIG. 2





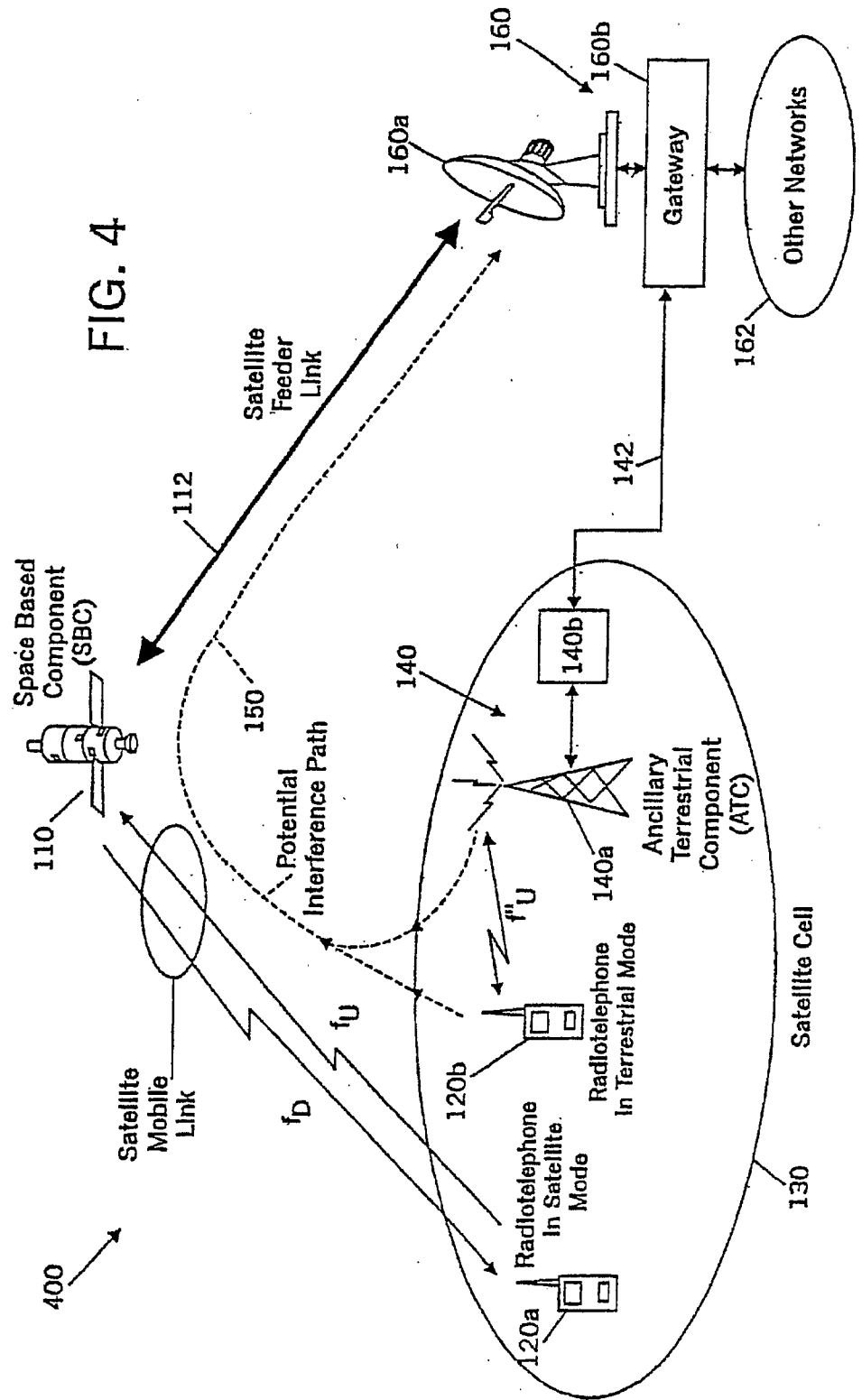

FIG. 6

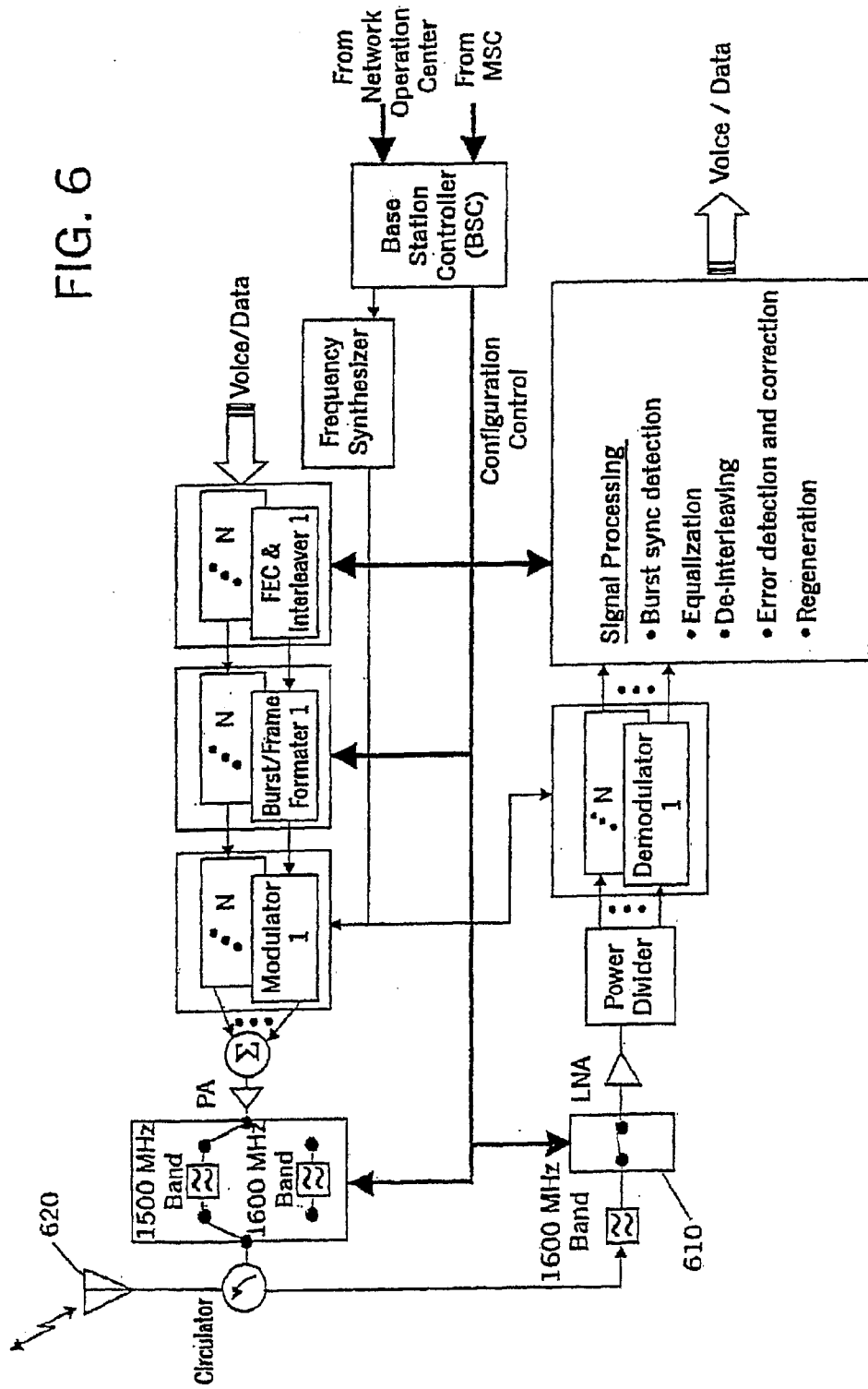
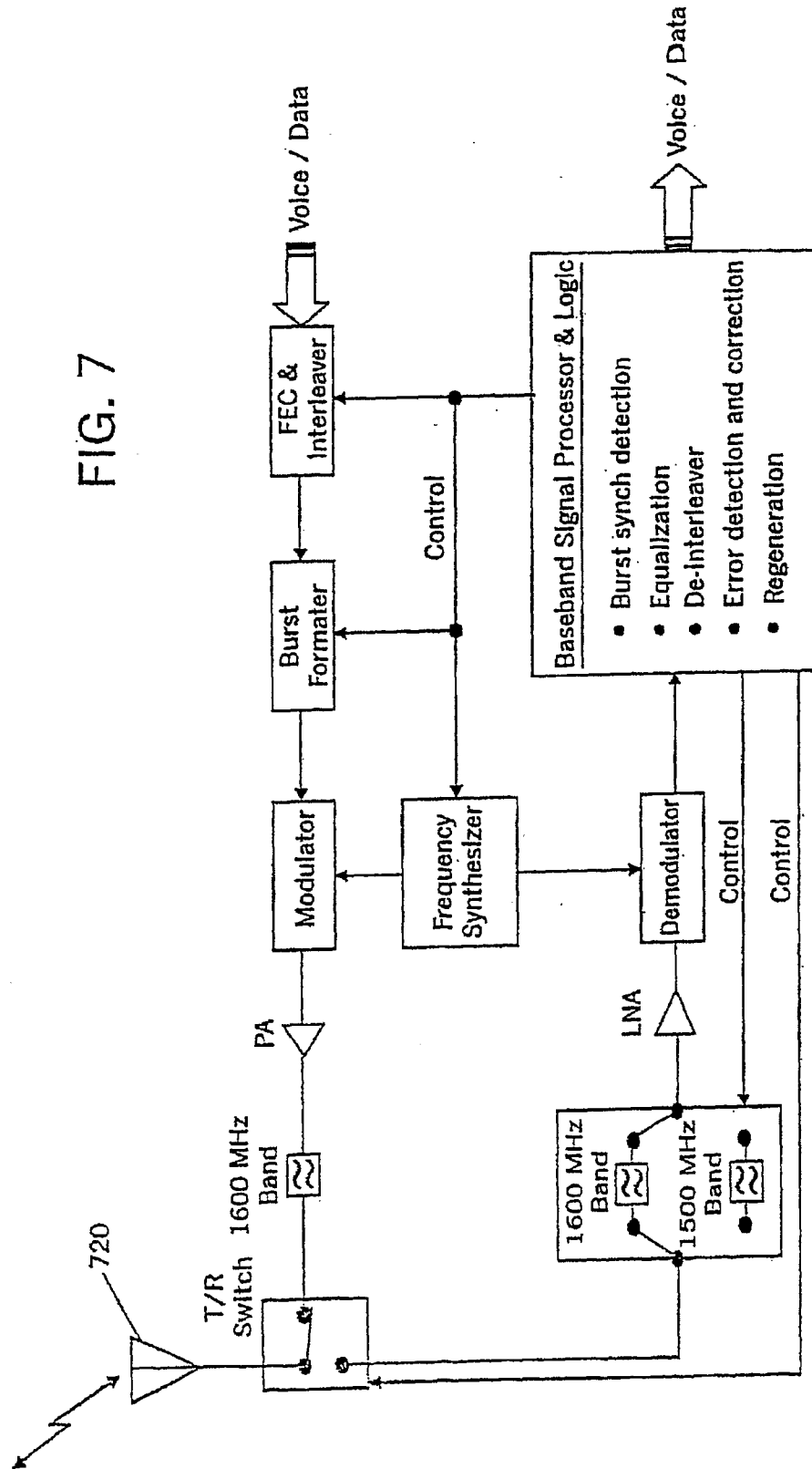

FIG. 7



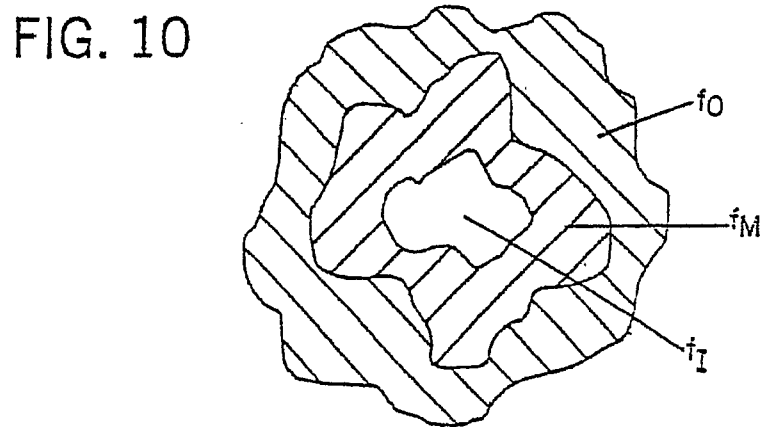
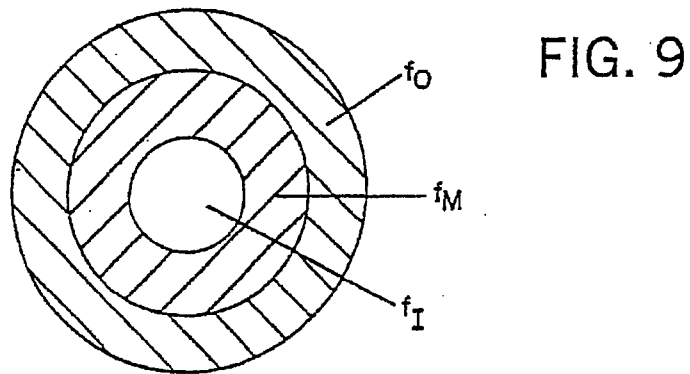
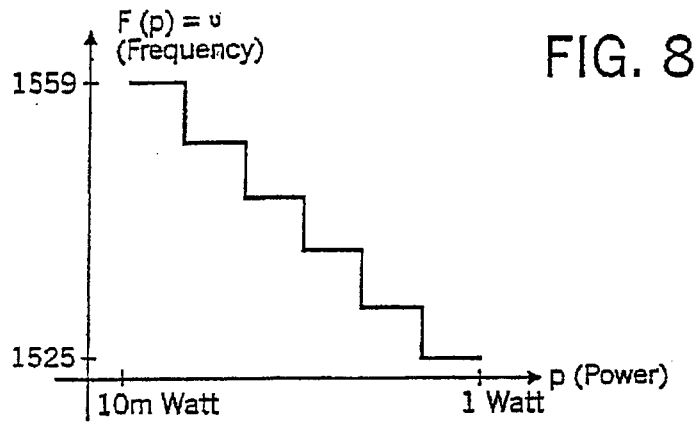

FIG. 11

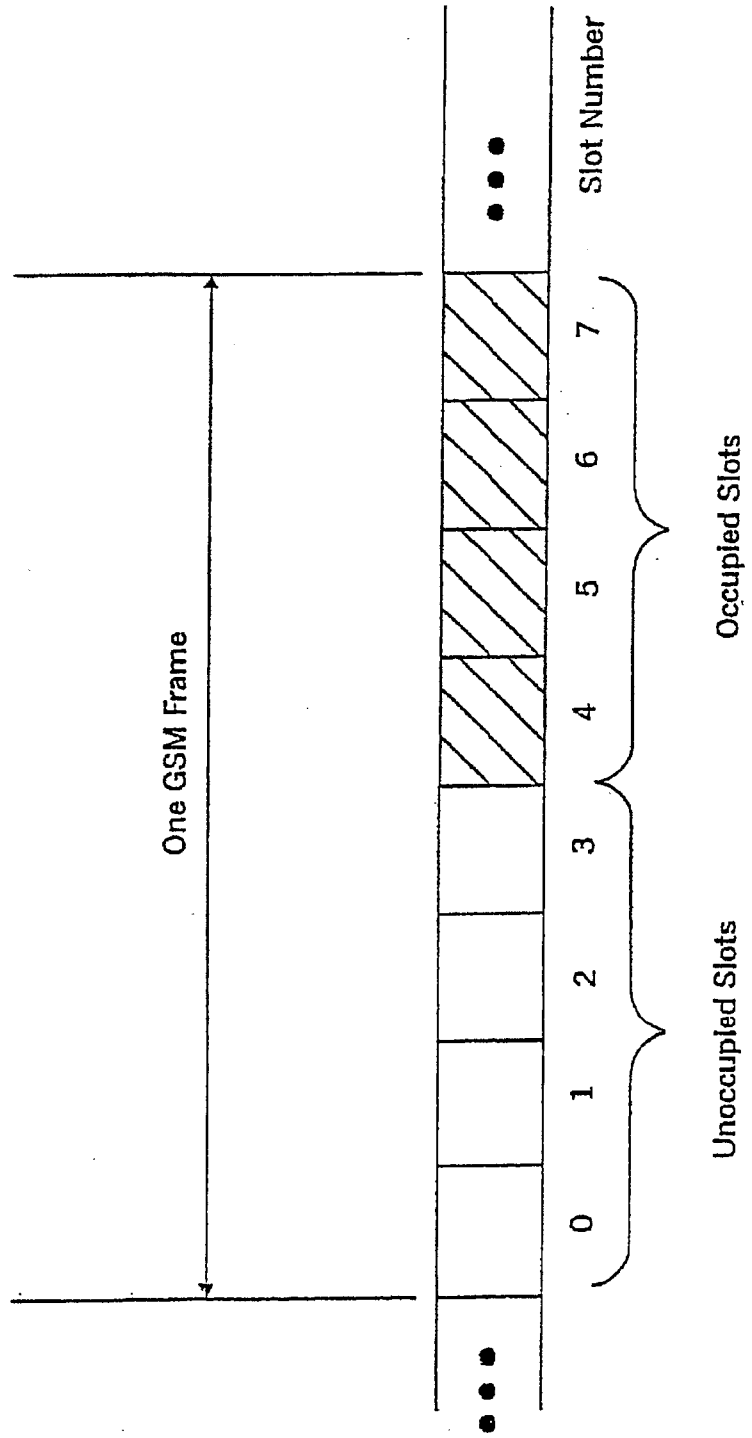
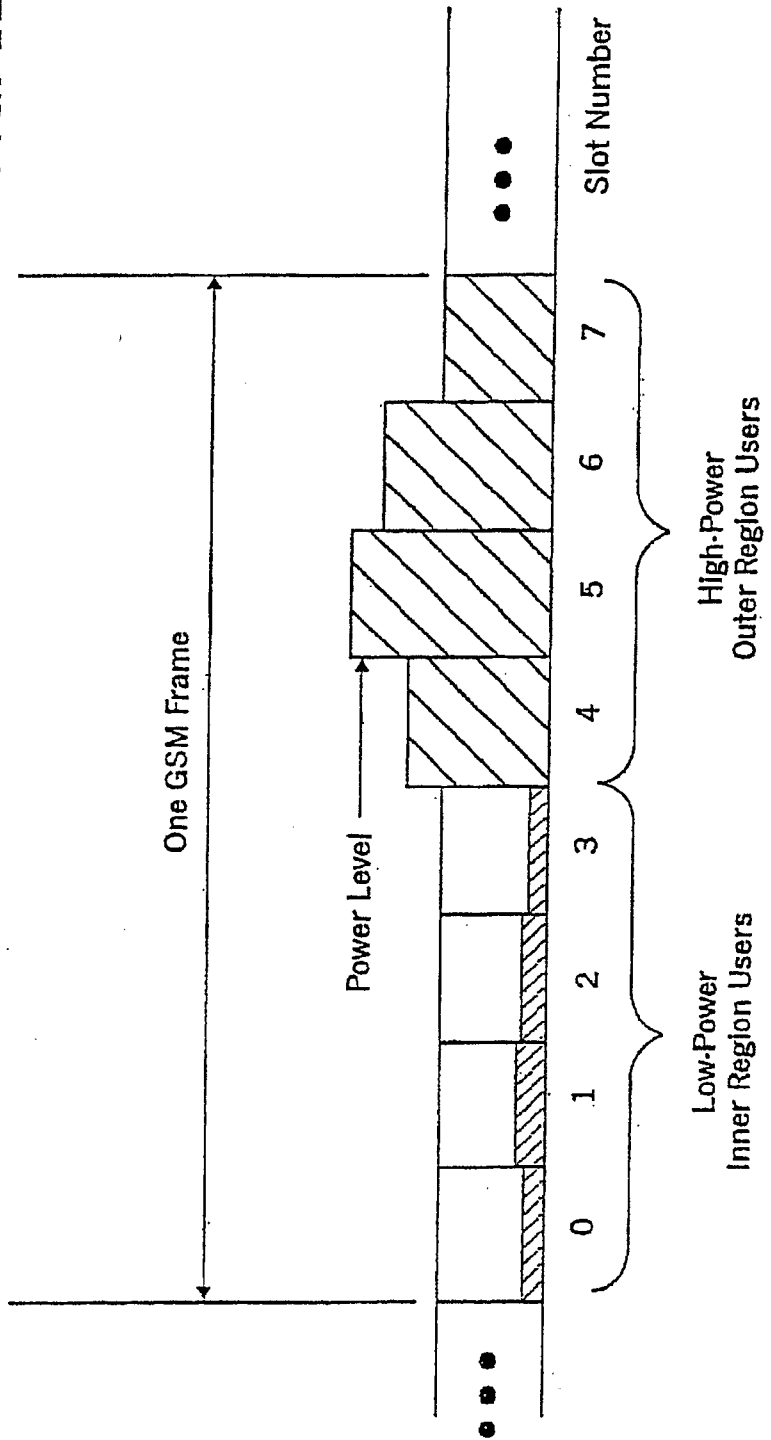

FIG. 12



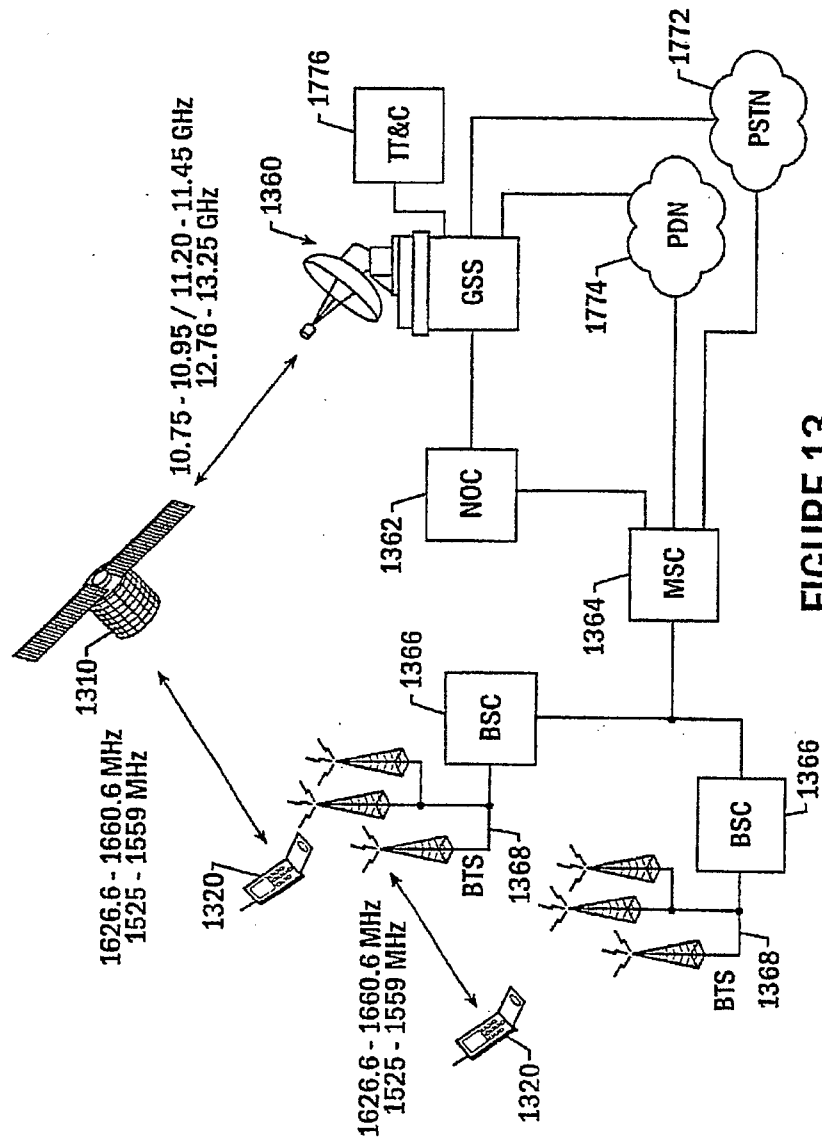
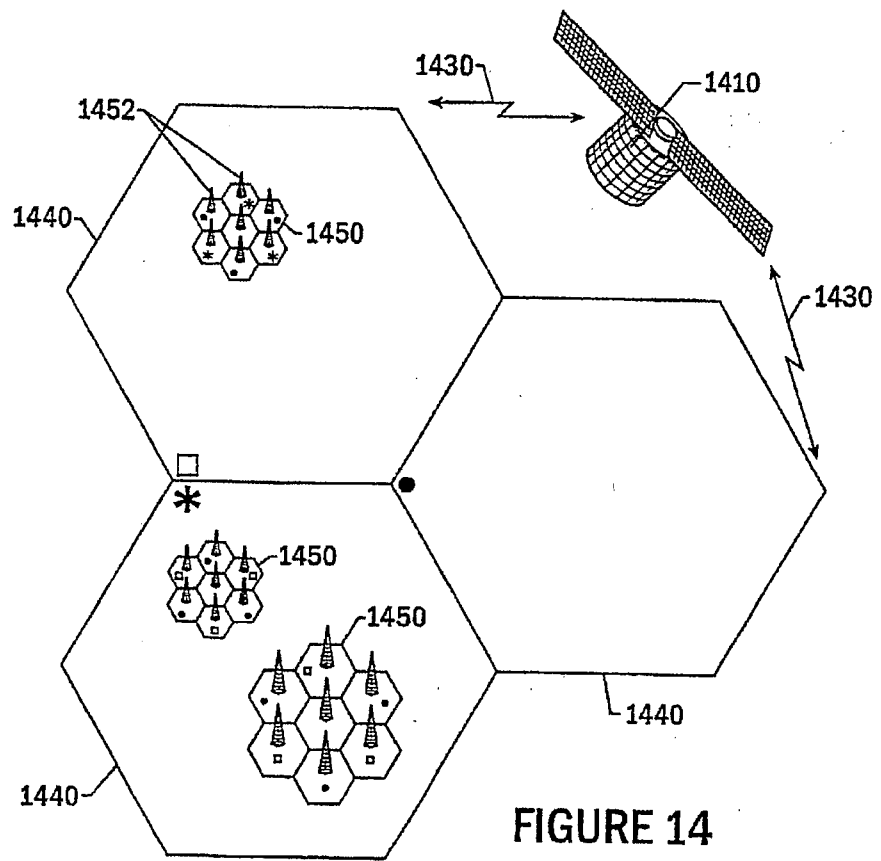

FIGURE 13



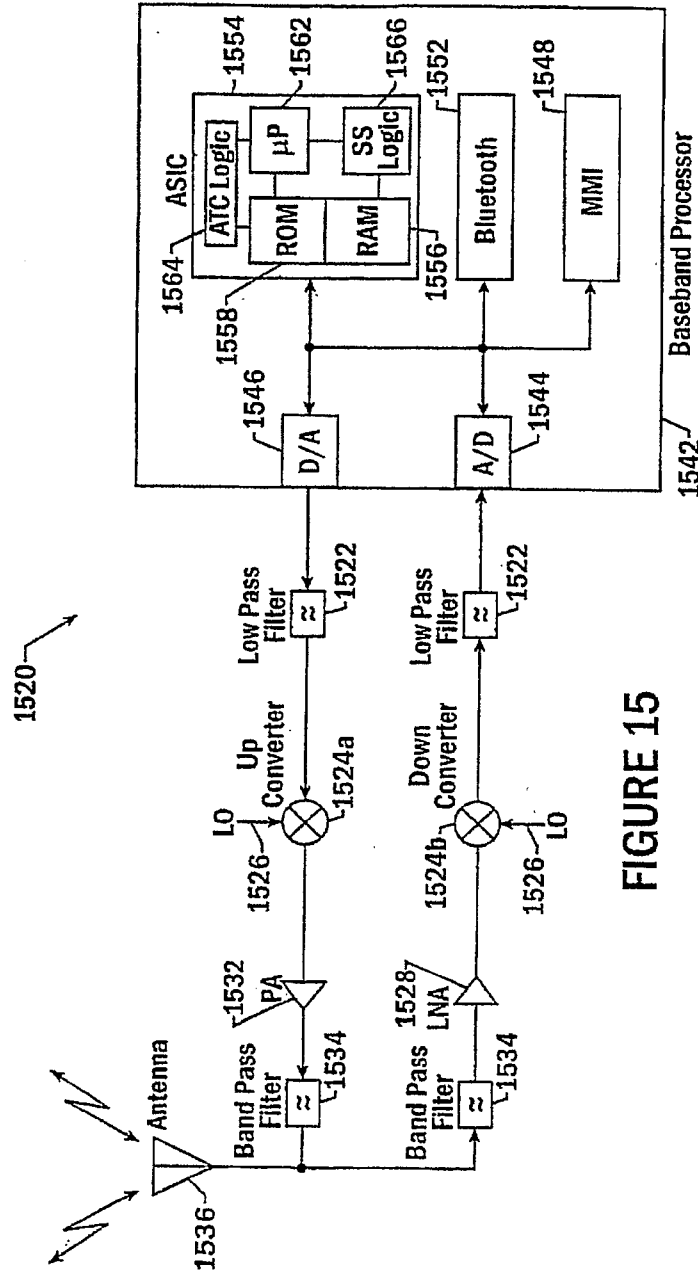

FIGURE 15

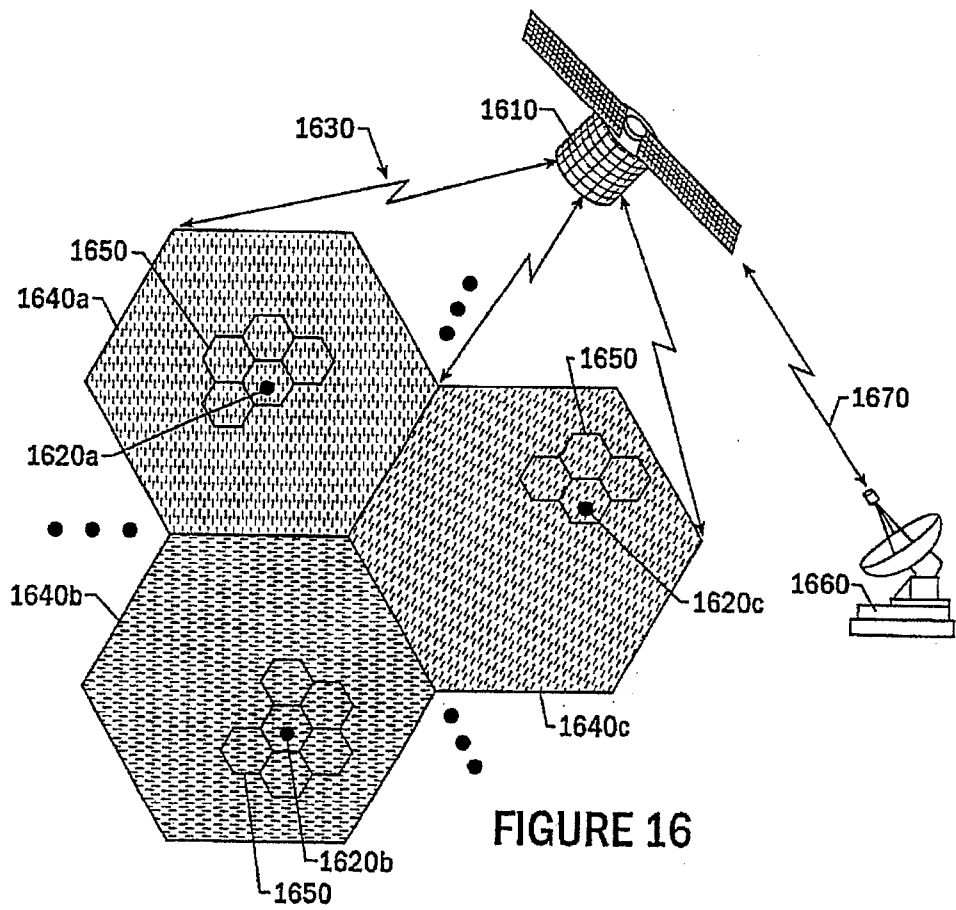

FIGURE 16

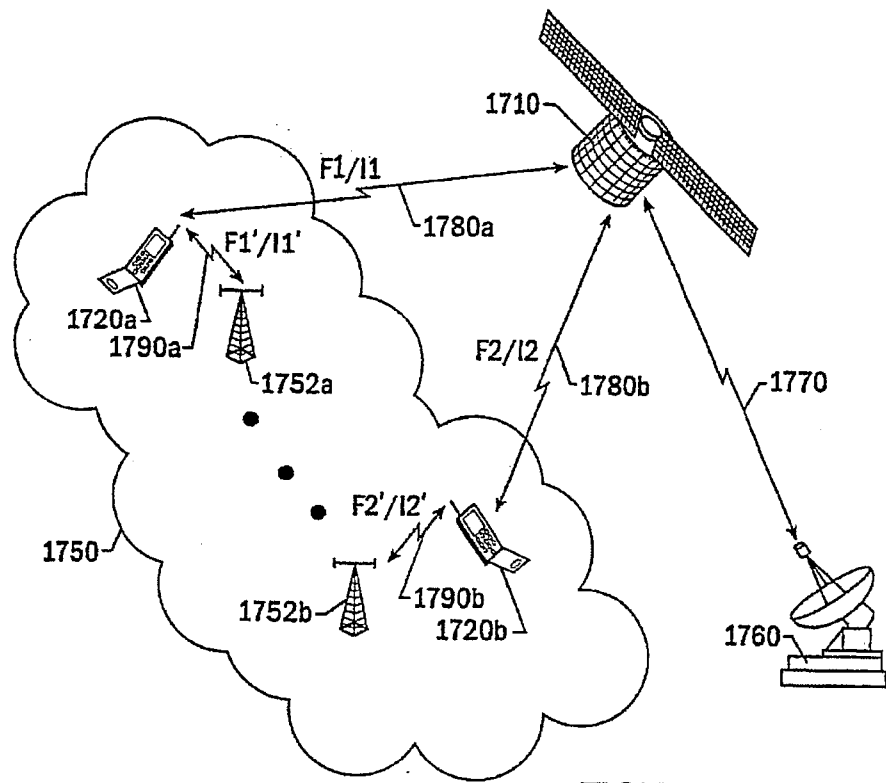

FIGURE 17

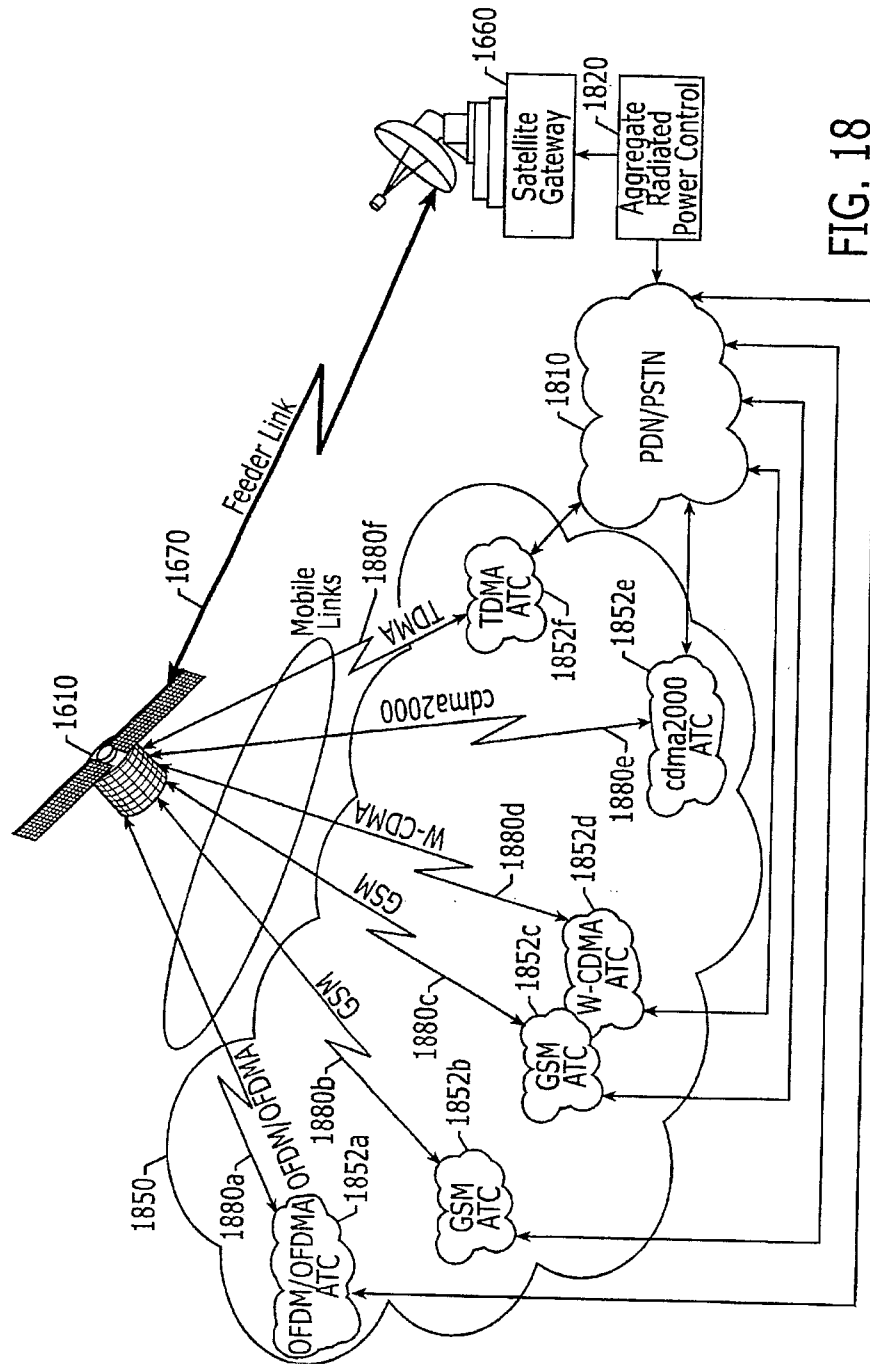

FIG. 18

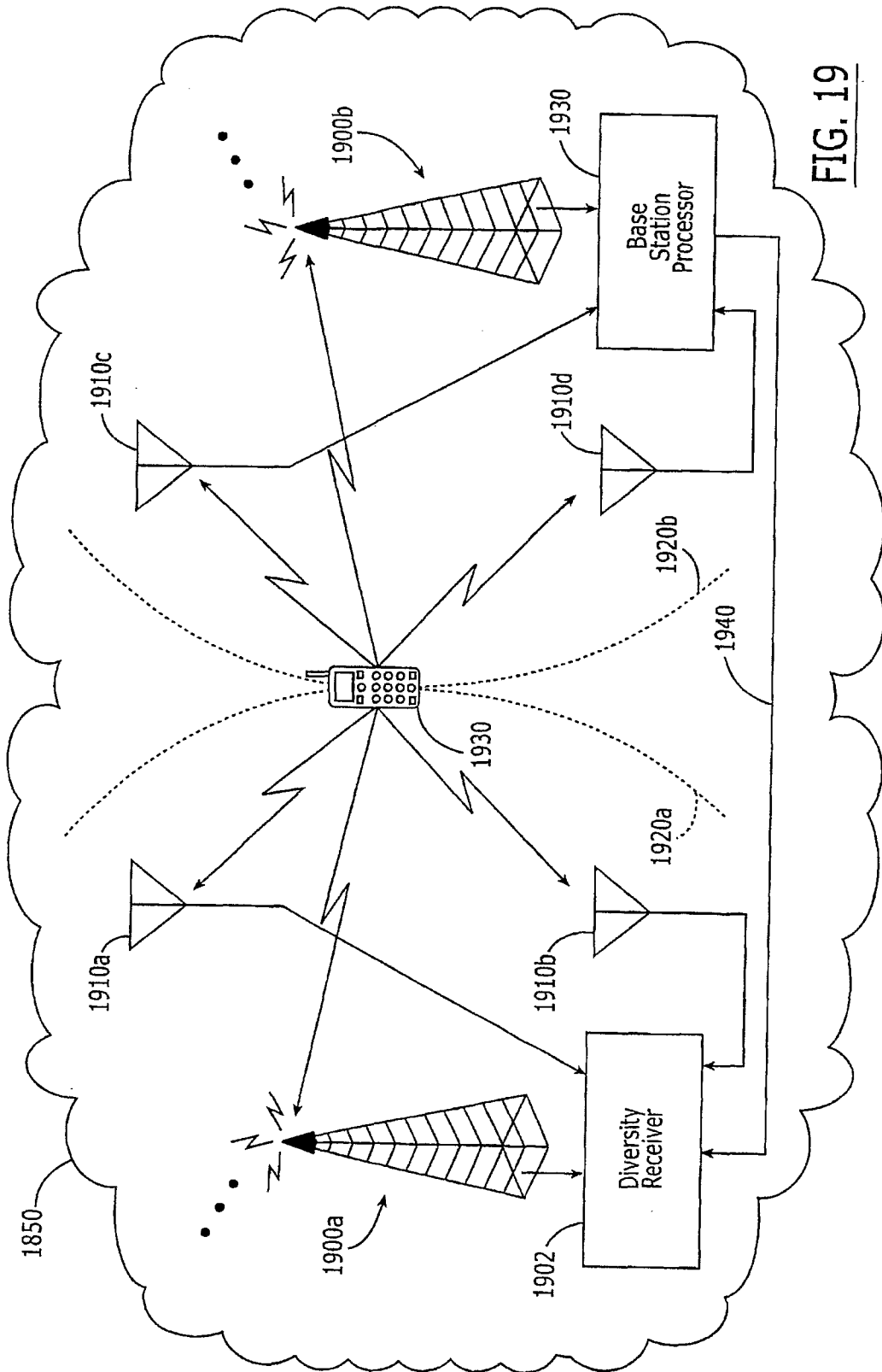

FIG. 19

