

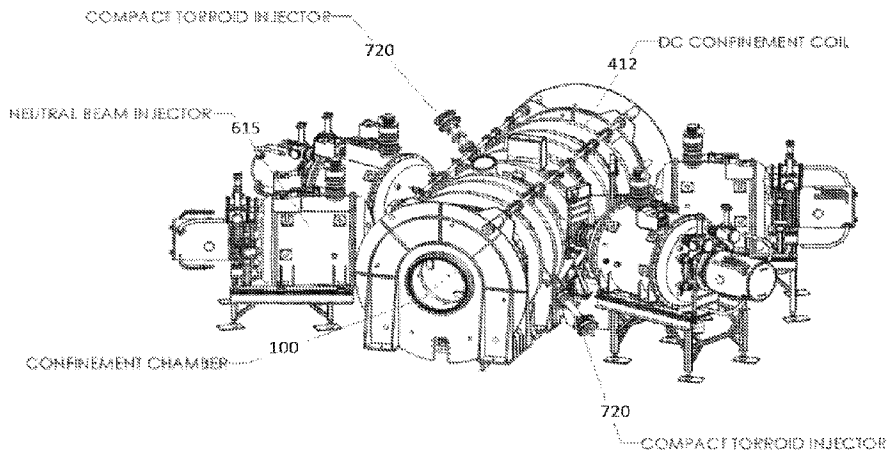

(86) Date de dépôt PCT/PCT Filing Date: 2015/10/30  
 (87) Date publication PCT/PCT Publication Date: 2016/05/06  
 (45) Date de délivrance/Issue Date: 2023/10/03  
 (85) Entrée phase nationale/National Entry: 2017/04/24  
 (86) N° demande PCT/PCT Application No.: US 2015/058473  
 (87) N° publication PCT/PCT Publication No.: 2016/070126  
 (30) Priorité/Priority: 2014/10/30 (US62/072,611)

(51) Cl.Int./Int.Cl. *H05H 1/08* (2006.01),  
*H05H 1/14* (2006.01), *H05H 3/00* (2006.01)  
 (72) Inventeurs/Inventors:  
BINDERBAUER, MICHL, US;  
GARATE, EUSEBIO, US;  
PUTVINSKI, SERGEI, US;  
GOTA, HIROSHI, US  
 (73) Propriétaire/Owner:  
TAE TECHNOLOGIES, INC., US  
 (74) Agent: SMART & BIGGAR LP

(54) Titre : SYSTEMES ET PROCEDES DE FORMATION ET DE MAINTIEN D'UNE FRC A HAUTE PERFORMANCE  
 (54) Title: SYSTEMS AND METHODS FOR FORMING AND MAINTAINING A HIGH PERFORMANCE FRC



(57) **Abrégé/Abstract:**

A high performance field reversed configuration (FRC) system includes a central confinement vessel, two diametrically opposed reversed-field-theta-pinch formation sections coupled to the vessel, and two divertor chambers coupled to the formation sections. A magnetic system includes quasi-dc coils axially positioned along the FRC system components, quasi-dc mirror coils between the confinement chamber and the formation sections, and mirror plugs between the formation sections and the divertors. The formation sections include modular pulsed power formation systems enabling static and dynamic formation and acceleration of the FRCs. The FRC system further includes neutral atom beam injectors, pellet or CT injectors, gettering systems, axial plasma guns and flux surface biasing electrodes. The beam injectors are preferably angled toward the midplane of the chamber. In operation, FRC plasma parameters including plasma thermal energy, total particle numbers, radius and trapped magnetic flux, are sustainable at or about a constant value without decay during neutral beam injection.

(12) INTERNATIONAL APPLICATION PUBLISHED UNDER THE PATENT COOPERATION TREATY (PCT)

(19) World Intellectual Property  
Organization  
International Bureau(43) International Publication Date  
6 May 2016 (06.05.2016)(10) International Publication Number  
**WO 2016/070126 A1**

## (51) International Patent Classification:

*H05H 1/14* (2006.01)      *H05H 3/00* (2006.01)  
*H05H 1/16* (2006.01)      *H05H 1/08* (2006.01)

## (21) International Application Number:

PCT/US2015/058473

## (22) International Filing Date:

30 October 2015 (30.10.2015)

## (25) Filing Language:

English

## (26) Publication Language:

English

## (30) Priority Data:

62/072,611      30 October 2014 (30.10.2014)      US

(71) Applicant: **TRI ALPHA ENERGY, INC.** [US/US];  
10631 Pauling, Foothill Ranch, California 92610 (US).(72) Inventors: **BINDERBAUER, Michl**; 10 Crespi Circle,  
Ladera Ranch, California 92694 (US). **GARATE, Eusebio**;  
56 Whitman Court, Irvine, California 92612 (US). **PUTVINSKI, Sergei**;  
24921 Muirlands Blvd., #132, Lake Forest, California 92630 (US). **GOTA, Hiroshi**;  
91 Long Meadow, Irvine, California 92620 (US).(74) Agent: **ROBERTS, Kenneth S.**; One LLP, 4000 Macarthur  
Blvd., East Tower, Suite 500, Newport Beach, California 92660 (US).(81) Designated States (unless otherwise indicated, for every  
kind of national protection available): AE, AG, AL, AM,  
AO, AT, AU, AZ, BA, BB, BG, BH, BN, BR, BW, BY,

BZ, CA, CH, CL, CN, CO, CR, CU, CZ, DE, DK, DM,  
DO, DZ, EC, EE, EG, ES, FI, GB, GD, GE, GH, GM, GT,  
HN, HR, HU, ID, IL, IN, IR, IS, JP, KE, KG, KN, KP, KR,  
KZ, LA, LC, LK, LR, LS, LU, LY, MA, MD, ME, MG,  
MK, MN, MW, MX, MY, MZ, NA, NG, NI, NO, NZ, OM,  
PA, PE, PG, PH, PL, PT, QA, RO, RS, RU, RW, SA, SC,  
SD, SE, SG, SK, SL, SM, ST, SV, SY, TH, TJ, TM, TN,  
TR, TT, TZ, UA, UG, US, UZ, VC, VN, ZA, ZM, ZW.

(84) Designated States (unless otherwise indicated, for every  
kind of regional protection available): ARIPO (BW, GH,  
GM, KE, LR, LS, MW, MZ, NA, RW, SD, SL, ST, SZ,  
TZ, UG, ZM, ZW), Eurasian (AM, AZ, BY, KG, KZ, RU,  
TJ, TM), European (AL, AT, BE, BG, CH, CY, CZ, DE,  
DK, EE, ES, FI, FR, GB, GR, HR, HU, IE, IS, IT, LT, LU,  
LV, MC, MK, MT, NL, NO, PL, PT, RO, RS, SE, SI, SK,  
SM, TR), OAPI (BF, BJ, CF, CG, CI, CM, GA, GN, GQ,  
GW, KM, ML, MR, NE, SN, TD, TG).

## Declarations under Rule 4.17:

— as to the applicant's entitlement to claim the priority of the  
earlier application (Rule 4.17(iii))

## Published:

— with international search report (Art. 21(3))  
— before the expiration of the time limit for amending the  
claims and to be republished in the event of receipt of  
amendments (Rule 48.2(h))

(54) Title: SYSTEMS AND METHODS FOR FORMING AND MAINTAINING A HIGH PERFORMANCE FRC

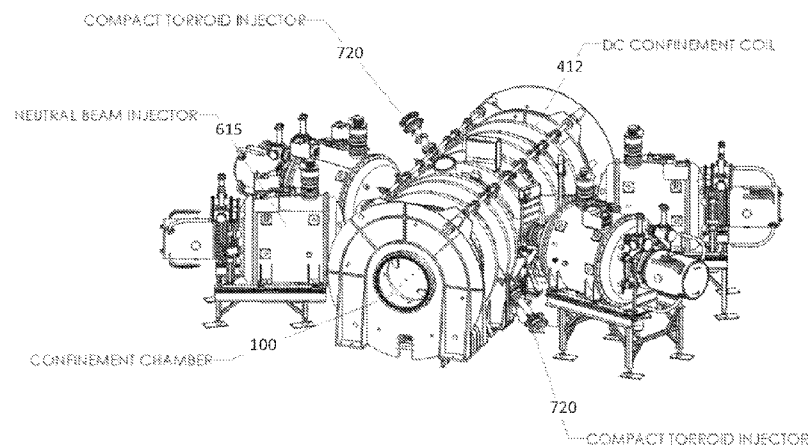

FIGURE 22A

(57) Abstract: A high performance field reversed configuration (FRC) system includes a central confinement vessel, two diametrically opposed reversed-field-theta-pinch formation sections coupled to the vessel, and two divertor chambers coupled to the formation sections. A magnetic system includes quasi-dc coils axially positioned along the FRC system components, quasi-dc mirror coils between the confinement chamber and the formation sections, and mirror plugs between the formation sections and the divertors. The formation sections include modular pulsed power formation systems enabling static and dynamic formation and acceleration of the FRCs. The FRC system further includes neutral atom beam injectors, pellet or CT injectors, gettering systems, axial plasma guns and flux surface biasing electrodes. The beam injectors are preferably angled toward the midplane of the chamber. In operation, FRC plasma parameters including plasma thermal energy, total particle numbers, radius and trapped magnetic flux, are sustainable at or about a constant value without decay during neutral beam injection.



WO 2016/070126 A1

## SYSTEMS AND METHODS FOR FORMING AND MAINTAINING A HIGH PERFORMANCE FRC

### FIELD

[0001] The embodiments described herein relate generally to magnetic plasma confinement systems and, more particularly, to systems and methods that facilitate forming and maintaining Field Reversed Configurations with superior stability as well as particle, energy and flux confinement.

### BACKGROUND INFORMATION

[0002] The Field Reversed Configuration (FRC) belongs to the class of magnetic plasma confinement topologies known as compact toroids (CT). It exhibits predominantly poloidal magnetic fields and possesses zero or small self-generated toroidal fields (see M. Tuszewski, Nucl. Fusion **28**, 2033 (1988)). The attractions of such a configuration are its simple geometry for ease of construction and maintenance, a natural unrestricted divertor for facilitating energy extraction and ash removal, and very high  $\beta$  ( $\beta$  is the ratio of the average plasma pressure to the average magnetic field pressure inside the FRC), *i.e.*, high power density. The high  $\beta$  nature is advantageous for economic operation and for the use of advanced, aneutronic fuels such as D-He<sup>3</sup> and p-B<sup>11</sup>.

[0003] The traditional method of forming an FRC uses the field-reversed  $\theta$ -pinch technology, producing hot, high-density plasmas (see A. L. Hoffman and J. T. Slough, Nucl. Fusion **33**, 27 (1993)). A variation on this is the *translation-trapping* method in which the plasma created in a theta-pinch “source” is more-or-less immediately ejected out one end into a confinement chamber. The translating plasmoid is then trapped between two strong mirrors at the ends of the chamber (see, for instance, H. Himura, S. Okada, S. Sugimoto, and S. Goto, Phys. Plasmas **2**, 191 (1995)). Once in the confinement chamber, various heating and current drive methods may be applied such as beam injection (neutral or neutralized), rotating magnetic fields, RF or ohmic heating, etc. This separation of source and confinement functions offers key engineering advantages for potential future fusion reactors. FRCs have proved to be extremely robust, resilient to dynamic formation, translation, and violent capture events. Moreover, they show a tendency to assume a preferred plasma state (see e.g. H. Y. Guo, A. L. Hoffman, K. E. Miller, and L. C. Steinhauer, Phys. Rev. Lett. **92**, 245001 (2004)). Significant progress has been made in the last decade developing other FRC formation methods: merging spheromaks with oppositely-directed helicities (see e.g. Y. Ono, M. Inomoto, Y. Ueda, T. Matsuyama, and T. Okazaki, Nucl. Fusion **39**, 2001 (1999)) and by driving current with rotating magnetic fields (RMF) (see e.g. I. R. Jones, Phys. Plasmas **6**, 1950 (1999)) which also provides additional stability.

[0004] Recently, the *collision-merging* technique, proposed long ago (see e.g. D. R. Wells, Phys. Fluids **9**, 1010 (1966)) has been significantly developed further: two separate theta-pinch

opposite ends of a confinement chamber simultaneously generate *two* plasmoids and accelerate the plasmoids toward each other at high speed; they then collide at the center of the confinement chamber and merge to form a compound FRC. In the construction and successful operation of one of the largest FRC experiments to date, the conventional collision-merging method was shown to produce stable, long-lived, high-flux, high temperature FRCs (see e.g. M. Binderbauer, H.Y. Guo, M. Tuszewski *et al.*, Phys. Rev. Lett. **105**, 045003 (2010)).

[0005] FRCs consist of a torus of closed field lines inside a separatrix, and of an annular edge layer on the open field lines just outside the separatrix. The edge layer coalesces into jets beyond the FRC length, providing a natural divertor. The FRC topology coincides with that of a Field-Reversed-Mirror plasma. However, a significant difference is that the FRC plasma has a  $\beta$  of about 10. The inherent low internal magnetic field provides for a certain indigenous kinetic particle population, i.e. particles with large larmor radii, comparable to the FRC minor radius. It is these strong kinetic effects that appear to at least partially contribute to the gross stability of past and present FRCs, such as those produced in the collision-merging experiment.

[0006] Typical past FRC experiments have been dominated by convective losses with energy confinement largely determined by particle transport. Particles diffuse primarily radially out of the separatrix volume, and are then lost axially in the edge layer. Accordingly, FRC confinement depends on the properties of both closed and open field line regions. The particle diffusion time out of the separatrix scales as  $\tau_{\perp} \sim a^2/D_{\perp}$  ( $a \sim r_s/4$ , where  $r_s$  is the central separatrix radius), and  $D_{\perp}$  is a characteristic FRC diffusivity, such as  $D_{\perp} \sim 12.5 \rho_{ie}$ , with  $\rho_{ie}$  representing the ion gyroradius, evaluated at an externally applied magnetic field. The edge layer particle confinement time  $\tau_{\parallel}$  is essentially an axial transit time in past FRC experiments. In steady-state, the balance between radial and axial particle losses yields a separatrix density gradient length  $\delta \sim (D_{\perp}\tau_{\parallel})^{1/2}$ . The FRC particle confinement time scales as  $(\tau_{\perp}\tau_{\parallel})^{1/2}$  for past FRCs that have substantial density at the separatrix (see e.g. M. TUSZEWSKI, "Field Reversed Configurations," Nucl. Fusion **28**, 2033 (1988)).

[0007] Another drawback of prior FRC system designs was the need to use external multipoles to control rotational instabilities such as the fast growing  $n=2$  interchange instabilities. In this way the typical externally applied quadrupole fields provided the required magnetic restoring pressure to dampen the growth of these unstable modes. While this technique is adequate for stability control of the thermal bulk plasma, it poses a severe problem for more kinetic FRCs or advanced hybrid FRCs, where a highly kinetic large orbit particle population is combined with the usual thermal plasma. In these systems, the distortions of the axisymmetric magnetic field due to such multipole fields leads to dramatic fast particle losses via collisionless stochastic diffusion, a consequence of the loss of conservation of canonical angular momentum. A novel solution to provide stability control without

enhancing diffusion of any particles is, thus, important to take advantage of the higher performance potential of these never-before explored advanced FRC concepts.

[0008] In light of the foregoing, it is, therefore, desirable to improve the confinement and stability of FRCs in order to use steady state FRCs as a pathway to a whole variety of applications including compact neutron sources (for medical isotope production, nuclear waste remediation, materials research, neutron radiography and tomography), compact photon sources (for chemical production and processing), mass separation and enrichment systems, and reactor cores for fusion of light nuclei for the future generation of energy.

#### SUMMARY

[0009] The present embodiments provided herein are directed to systems and methods that facilitate the formation and maintenance of new High Performance Field Reversed Configurations (FRCs). In accordance with this new High Performance FRC paradigm, the present system combines a host of novel ideas and means to dramatically improve FRC confinement of particles, energy and flux as well as provide stability control without negative side-effects.

[0010] An FRC system provided herein includes a central confinement vessel surrounded by two diametrically opposed reversed-field-theta-pinch formation sections and, beyond the formation sections, two divertor chambers to control neutral density and impurity contamination. A magnetic system includes a series of quasi-dc coils that are situated at axial positions along the components of the FRC system, quasi-dc mirror coils between either end of the confinement chamber and the adjacent formation sections, and mirror plugs comprising compact quasi-dc mirror coils between each of the formation sections and divertors that produce additional guide fields to focus the magnetic flux surfaces towards the divertor. The formation sections include modular pulsed power formation systems that enable FRCs to be formed in-situ and then accelerated and injected (=static formation) or formed and accelerated simultaneously (=dynamic formation).

[0011] The FRC system includes neutral atom beam injectors and a pellet injector. In one embodiment, beam injectors are angled to inject neutral particles towards the mid-plane. Having the beam injectors angled towards the mid-plane and with axial beam positions close to the mid-plane improves beam-plasma coupling, even as the FRC plasma shrinks or otherwise axially contracts during the injection period. Gettering systems are also included as well as axial plasma guns. Biasing electrodes are also provided for electrical biasing of open flux surfaces.

[0012] In operation, FRC global plasma parameters including plasma thermal energy, total particle numbers, plasma radius and length, as well as magnetic flux, are substantially sustainable without

decay while neutral beams are injected into the plasma and pellets provide appropriate particle refueling.

[0013] In an alternative embodiment, a compact toroid (CT) injector is provided in lieu of the pellet injector to provide appropriate particle refueling by injecting a Spheromak-like plasma.

[0013a] Some embodiments disclosed herein provide a method for generating and maintaining a magnetic field with a field reversed configuration (FRC) comprising the steps of: forming an FRC about a plasma in a confinement chamber, and maintaining the FRC at or about a constant value without decay by injecting beams of neutral atoms from neutral beam injectors into the FRC plasma at an angle towards a mid-plane of the confinement chamber and injecting a compact toroid plasma into the FRC.

[0013b] Some embodiments disclosed herein provide a system for generating and maintaining a magnetic field with a field reversed configuration (FRC) comprising a confinement chamber, first and second diametrically opposed FRC formation sections coupled to the confinement chamber, the formation section comprising modularized formation systems for generating an FRC and translating the FRC toward a midplane of the confinement chamber, first and second divertors coupled to the first and second formation sections, first and second axial plasma guns operably coupled to the first and second divertors, the first and second formation sections and the confinement chamber, a plurality of neutral atom beam injectors coupled to the confinement chamber and oriented to inject neutral atom beams toward a mid-plane of the confinement chamber at an angle less than normal to a longitudinal axis of the confinement chamber, a magnetic system comprising a plurality of quasi-dc coils positioned around the confinement chamber, the first and second formation sections, and the first and second divertors, first and second set of quasi-dc mirror coils positioned between the confinement chamber and the first and second formation sections, and first and second mirror plugs positioned between the first and second formation sections and the first and second divertors, a gettering system coupled to the confinement chamber and the first and second divertors, one or more biasing electrodes for electrically biasing open flux surface of a generated FRC, the one or more biasing electrodes being positioned within one or more of the confinement chamber, the first and second formation sections, and the first and second divertors, two or more saddle coils coupled to the confinement chamber, and a CT injector coupled to the confinement chamber.

[0014] The systems, methods, features and advantages of the invention will be or will become apparent to one with skill in the art upon examination of the following figures and detailed description. It is intended that all such additional methods, features and advantages be included

within this description, be within the scope of the invention, and be protected by the accompanying claims. It is also intended that the invention is not limited to require the details of the example embodiments.

#### BRIEF DESCRIPTION OF THE FIGURES

[0015] The accompanying drawings, which are included as part of the present specification, illustrate the presently preferred embodiment and, together with the general description given above and the detailed description of the preferred embodiment given below, serve to explain and teach the principles of the present invention.

[0016] Figure 1 illustrates particle confinement in the present FRC system under a high performance FRC regime (HPF) versus under a conventional FRC regime (CR), and versus other conventional FRC experiments.

[0017] Figure 2 illustrates the components of the present FRC system and the magnetic topology of an FRC producible in the present FRC system.

[0018] Figure 3A illustrates the basic layout of the present FRC system as viewed from the top, including the preferred arrangement of neutral beams, electrodes, plasma guns, mirror plugs and pellet injector.

[0019] Figure 3B illustrates the central confinement vessel as viewed from the top and showing the neutral beams arranged at an angle normal to the major axis of symmetry in the central confinement vessel.

[0020] Figure 3C illustrates the central confinement vessel as viewed from the top and showing the neutral beams arranged at an angle less than normal to the major axis of symmetry in the central confinement vessel and directed to inject particles toward the mid-plane of the central confinement vessel.

[0021] Figure 4 illustrates a schematic of the components of a pulsed power system for the formation sections.

[0022] Figure 5 illustrates an isometric view of an individual pulsed power formation skid.

[0023] **Figure 6** illustrates an isometric view of a formation tube assembly.

[0024] **Figure 7** illustrates a partial sectional isometric view of neutral beam system and key components.

[0025] **Figure 8** illustrates an isometric view of the neutral beam arrangement on confinement chamber.

[0026] **Figure 9** illustrates a partial sectional isometric view of a preferred arrangement of the Ti and Li gettering systems.

[0027] **Figure 10** illustrates a partial sectional isometric view of a plasma gun installed in the divertor chamber. Also shown are the associated magnetic mirror plug and a divertor electrode assembly.

[0028] **Figure 11** illustrates a preferred layout of an annular bias electrode at the axial end of the confinement chamber.

[0029] **Figure 12** illustrates the evolution of the excluded flux radius in the FRC system obtained from a series of external diamagnetic loops at the two field reversed theta pinch formation sections and magnetic probes embedded inside the central metal confinement chamber. Time is measured from the instant of synchronized field reversal in the formation sources, and distance  $z$  is given relative to the axial midplane of the machine.

[0030] **Figures 13 (a) through (d)** illustrate data from a representative non-HPF, un-sustained discharge on the present FRC system. Shown as functions of time are (a) excluded flux radius at the midplane, (b) 6 chords of line-integrated density from the midplane CO<sub>2</sub> interferometer, (c) Abel-inverted density radial profiles from the CO<sub>2</sub> interferometer data, and (d) total plasma temperature from pressure balance.

[0031] **Figure 14** illustrates the excluded flux axial profiles at selected times for the same discharge of the present FRC system shown in Figure 13.

[0032] **Figure 15** illustrates an isometric view of the saddle coils mounted outside of the confinement chamber.

[0033] **Figure 16** illustrates the correlations of FRC lifetime and pulse length of injected neutral beams. As shown, longer beam pulses produce longer lived FRCs.

[0034] **Figure 17** illustrate the individual and combined effects of different components of the FRC system on FRC performance and the attainment of the HPF regime.

[0035] **Figures 18(a) through (d)** illustrate data from a representative HPF, un-sustained discharge on the present FRC system. Shown as functions of time are (a) excluded flux radius at the midplane, (b) 6 chords of line-integrated density from the midplane CO<sub>2</sub> interferometer, (c) Abel-inverted

density radial profiles from the CO<sub>2</sub> interferometer data, and (d) total plasma temperature from pressure balance.

[0036] **Figure 19** illustrates flux confinement as a function of electron temperature ( $T_e$ ). It represents a graphical representation of a newly established superior scaling regime for HPF discharges.

[0037] **Figure 20** illustrates the FRC lifetime corresponding to the pulse length of non-angled and angled injected neutral beams.

[0038] **Figures 21A and 21B** illustrate the basic layout of a compact toroid (CT) injector.

[0039] **Figures 22A and 22B** illustrate the central confinement vessel showing the CT injector mounted thereto.

[0040] **Figures 23A and 23B** illustrate the basic layout of an alternative embodiment of the CT injector having a drift tube coupled thereto.

[0041] It should be noted that the figures are not necessarily drawn to scale and that elements of similar structures or functions are generally represented by like reference numerals for illustrative purposes throughout the figures. It also should be noted that the figures are only intended to facilitate the description of the various embodiments described herein. The figures do not necessarily describe every aspect of the teachings disclosed herein and do not limit the scope of the claims.

#### DETAILED DESCRIPTION

[0042] The present embodiments provided herein are directed to systems and methods that facilitate forming and maintaining High Performance Field Reversed Configurations (FRCs) with superior stability as well as superior particle, energy and flux confinement over conventional FRCs. Such High Performance FRCs provide a pathway to a whole variety of applications including compact neutron sources (for medical isotope production, nuclear waste remediation, materials research, neutron radiography and tomography), compact photon sources (for chemical production and processing), mass separation and enrichment systems, and reactor cores for fusion of light nuclei for the future generation of energy.

[0043] Various ancillary systems and operating modes have been explored to assess whether there is a superior confinement regime in FRCs. These efforts have led to breakthrough discoveries and the development of a High Performance FRC paradigm described herein. In accordance with this new paradigm, the present systems and methods combine a host of novel ideas and means to dramatically improve FRC confinement as illustrated in Figure 1 as well as provide stability control without negative side-effects. As discussed in greater detail below, Figure 1 depicts particle confinement in

an FRC system 10 described below (see Figures 2 and 3), operating in accordance with a High Performance FRC regime (HPF) for forming and maintaining an FRC versus operating in accordance with a conventional regime CR for forming and maintaining an FRC, and versus particle confinement in accordance with conventional regimes for forming and maintaining an FRC used in other experiments. The present disclosure will outline and detail the innovative individual components of the FRC system 10 and methods as well as their collective effects.

### Description of the FRC System

#### *Vacuum System*

[0044] Figures 2 and 3 depict a schematic of the present FRC system 10. The FRC system 10 includes a central confinement vessel 100 surrounded by two diametrically opposed reversed-field-theta-pinch formation sections 200 and, beyond the formation sections 200, two divertor chambers 300 to control neutral density and impurity contamination. The present FRC system 10 was built to accommodate ultrahigh vacuum and operates at typical base pressures of  $10^{-8}$  torr. Such vacuum pressures require the use of double-pumped mating flanges between mating components, metal O-rings, high purity interior walls, as well as careful initial surface conditioning of all parts prior to assembly, such as physical and chemical cleaning followed by a 24 hour 250 °C vacuum baking and Hydrogen glow discharge cleaning.

[0045] The reversed-field-theta-pinch formation sections 200 are standard field-reversed-theta-pinches (FRTPs), albeit with an advanced pulsed power formation system discussed in detail below (see Figures 4 through 6). Each formation section 200 is made of standard opaque industrial grade quartz tubes that feature a 2 millimeter inner lining of ultrapure quartz. The confinement chamber 100 is made of stainless steel to allow a multitude of radial and tangential ports; it also serves as a flux conserver on the timescale of the experiments described below and limits fast magnetic transients. Vacuums are created and maintained within the FRC system 10 with a set of dry scroll roughing pumps, turbo molecular pumps and cryo pumps.

#### *Magnetic System*

[0046] The magnetic system 400 is illustrated in Figures 2 and 3. Figure 2, amongst other features, illustrates an FRC magnetic flux and density contours (as functions of the radial and axial coordinates) pertaining to an FRC 450 producible by the FRC system 10. These contours were obtained by a 2-D resistive Hall-MHD numerical simulation using code developed to simulate systems and methods corresponding to the FRC system 10, and agree well with measured experimental data. As seen in Figure 2, the FRC 450 consists of a torus of closed field lines at the interior 453 of the FRC 450 inside a separatrix 451, and of an annular edge layer 456 on the open

field lines 452 just outside the separatrix 451. The edge layer 456 coalesces into jets 454 beyond the FRC length, providing a natural divertor.

[0047] The main magnetic system 410 includes a series of quasi-dc coils 412, 414, and 416 that are situated at particular axial positions along the components, i.e., along the confinement chamber 100, the formation sections 200 and the divertors 300, of the FRC system 10. The quasi-dc coils 412, 414 and 416 are fed by quasi-dc switching power supplies and produce basic magnetic bias fields of about 0.1 T in the confinement chamber 100, the formation sections 200 and the divertors 300. In addition to the quasi-dc coils 412, 414 and 416, the main magnetic system 410 includes quasi-dc mirror coils 420 (fed by switching supplies) between either end of the confinement chamber 100 and the adjacent formation sections 200. The quasi-dc mirror coils 420 provide magnetic mirror ratios of up to 5 and can be independently energized for equilibrium shaping control. In addition, mirror plugs 440, are positioned between each of the formation sections 200 and divertors 300. The mirror plugs 440 comprise compact quasi-dc mirror coils 430 and mirror plug coils 444. The quasi-dc mirror coils 430 include three coils 432, 434 and 436 (fed by switching supplies) that produce additional guide fields to focus the magnetic flux surfaces 455 towards the small diameter passage 442 passing through the mirror plug coils 444. The mirror plug coils 444, which wrap around the small diameter passage 442 and are fed by LC pulsed power circuitry, produce strong magnetic mirror fields of up to 4 T. The purpose of this entire coil arrangement is to tightly bundle and guide the magnetic flux surfaces 455 and end-streaming plasma jets 454 into the remote chambers 310 of the divertors 300. Finally, a set of saddle-coil “antennas” 460 (see Figure 15) are located outside the confinement chamber 100, two on each side of the mid-plane, and are fed by dc power supplies. The saddle-coil antennas 460 can be configured to provide a quasi-static magnetic dipole or quadrupole field of about 0.01 T for controlling rotational instabilities and/or electron current control. The saddle-coil antennas 460 can flexibly provide magnetic fields that are either symmetric or antisymmetric about the machine’s midplane, depending on the direction of the applied currents.

#### *Pulsed power formation systems*

[0048] The pulsed power formation systems 210 operate on a modified theta-pinch principle. There are two systems that each power one of the formation sections 200. Figures 4 through 6 illustrate the main building blocks and arrangement of the formation systems 210. The formation system 210 is composed of a modular pulsed power arrangement that consists of individual units (=skids) 220 that each energize a sub-set of coils 232 of a strap assembly 230 (=straps) that wrap around the formation quartz tubes 240. Each skid 220 is composed of capacitors 221, inductors 223, fast high current switches 225 and associated trigger 222 and dump circuitry 224. In total, each formation system 210

stores between 350-400 kJ of capacitive energy, which provides up to 35 GW of power to form and accelerate the FRCs. Coordinated operation of these components is achieved via a state-of-the-art trigger and control system 222 and 224 that allows synchronized timing between the formation systems 210 on each formation section 200 and minimizes switching jitter to tens of nanoseconds. The advantage of this modular design is its flexible operation: FRCs can be formed in-situ and then accelerated and injected (=static formation) or formed and accelerated at the same time (=dynamic formation).

### *Neutral Beam Injectors*

[0049] Neutral atom beams 600 are deployed on the FRC system 10 to provide heating and current drive as well as to develop fast particle pressure. As shown in Figures 3A, 3B and 8, the individual beam lines comprising neutral atom beam injector systems 610 and 640 are located around the central confinement chamber 100 and inject fast particles tangentially to the FRC plasma (and perpendicular or at an angle normal to the major axis of symmetry in the central confinement vessel 100) with an impact parameter such that the target trapping zone lies well within the separatrix 451 (see Figure 2). Each injector system 610 and 640 is capable of injecting up to 1 MW of neutral beam power into the FRC plasma with particle energies between 20 and 40 keV. The systems 610 and 640 are based on positive ion multi-aperture extraction sources and utilize geometric focusing, inertial cooling of the ion extraction grids and differential pumping. Apart from using different plasma sources, the systems 610 and 640 are primarily differentiated by their physical design to meet their respective mounting locations, yielding side and top injection capabilities. Typical components of these neutral beam injectors are specifically illustrated in Figure 7 for the side injector systems 610. As shown in Figure 7, each individual neutral beam system 610 includes an RF plasma source 612 at an input end (this is substituted with an arc source in systems 640) with a magnetic screen 614 covering the end. An ion optical source and acceleration grids 616 is coupled to the plasma source 612 and a gate valve 620 is positioned between the ion optical source and acceleration grids 616 and a neutralizer 622. A deflection magnet 624 and an ion dump 628 are located between the neutralizer 622 and an aiming device 630 at the exit end. A cooling system comprises two cryo-refrigerators 634, two cryopanel 636 and a LN2 shroud 638. This flexible design allows for operation over a broad range of FRC parameters.

[0050] An alternative configuration for the neutral atom beam injectors 600 is that of injecting the fast particles tangentially to the FRC plasma, but with an angle  $A$  less than  $90^\circ$  relative to the major axis of symmetry in the central confinement vessel 100. These types of orientation of the beam injectors 615 are shown in Figure 3C. In addition, the beam injectors 615 may be oriented such that

the beam injectors 615 on either side of the mid-plane of the central confinement vessel 100 inject their particles towards the mid-plane. Finally, the axial position of these beam systems 600 may be chosen closer to the mid-plane. These alternative injection embodiments facilitate a more central fueling option, which provides for better coupling of the beams and higher trapping efficiency of the injected fast particles. Furthermore, depending on the angle and axial position, this arrangement of the beam injectors 615 allows more direct and independent control of the axial elongation and other characteristics of the FRC 450. For instance, injecting the beams at a shallow angle  $A$  relative to the vessel's major axis of symmetry will create an FRC plasma with longer axial extension and lower temperature while picking a more perpendicular angle  $A$  will lead to an axially shorter but hotter plasma. In this fashion the injection angle  $A$  and location of the beam injectors 615 can be optimized for different purposes. In addition, such angling and positioning of the beam injectors 615 can allow beams of higher energy (which is generally more favorable for depositing more power with less beam divergence) to be injected into lower magnetic fields than would otherwise be necessary to trap such beams. This is due to the fact that it is the azimuthal component of the energy that determines fast ion orbit scale (which becomes progressively smaller as the injection angle relative to the vessel's major axis of symmetry is reduced at constant beam energy). Furthermore, angled injection towards the mid-plane and with axial beam positions close to the mid-plane improves beam-plasma coupling, even as the FRC plasma shrinks or otherwise axially contracts during the injection period.

#### *Pellet Injector*

[0051] To provide a means to inject new particles and better control FRC particle inventory, a 12-barrel pellet injector 700 (see e.g. I. Vinyar et al., "Pellet Injectors Developed at PELIN for JET, TAE, and HL-2A," Proceedings of the 26<sup>th</sup> Fusion Science and Technology Symposium, 09/27 to 10/01 (2010)) is utilized on FRC system 10. Figure 3 illustrates the layout of the pellet injector 700 on the FRC system 10. The cylindrical pellets ( $D \sim 1$  mm,  $L \sim 1 - 2$  mm) are injected into the FRC with a velocity in the range of 150 – 250 km/s. Each individual pellet contains about  $5 \times 10^{19}$  hydrogen atoms, which is comparable to the FRC particle inventory.

#### *Gettering Systems*

[0052] It is well known that neutral halo gas is a serious problem in all confinement systems. The charge exchange and recycling (release of cold impurity material from the wall) processes can have a devastating effect on energy and particle confinement. In addition, any significant density of neutral gas at or near the edge will lead to prompt losses of or at least severely curtail the lifetime of injected large orbit (high energy) particles (large orbit refers to particles having orbits on the scale of the FRC topology or at least orbit radii much larger than the characteristic magnetic field gradient length

scale) – a fact that is detrimental to all energetic plasma applications, including fusion via auxiliary beam heating.

[0053] Surface conditioning is a means by which the detrimental effects of neutral gas and impurities can be controlled or reduced in a confinement system. To this end the FRC system 10 provided herein employs Titanium and Lithium deposition systems 810 and 820 that coat the plasma facing surfaces of the confinement chamber (or vessel) 100 and diverters 300 with films (tens of micrometers thick) of Ti and/or Li. The coatings are achieved via vapor deposition techniques. Solid Li and/or Ti are evaporated and/or sublimated and sprayed onto nearby surfaces to form the coatings. The sources are atomic ovens with guide nozzles (in case of Li) 822 or heated spheres of solid with guide shrouding (in case of Ti) 812. Li evaporator systems typically operate in a continuous mode while Ti sublimators are mostly operated intermittently in between plasma operation. Operating temperatures of these systems are above 600 °C to obtain fast deposition rates. To achieve good wall coverage, multiple strategically located evaporator/sublimator systems are necessary. Figure 9 details a preferred arrangement of the gettering deposition systems 810 and 820 in the FRC system 10. The coatings act as gettering surfaces and effectively pump atomic and molecular hydrogenic species (H and D). The coatings also reduce other typical impurities such as Carbon and Oxygen to insignificant levels.

#### *Mirror Plugs*

[0054] As stated above, the FRC system 10 employs sets of mirror coils 420, 430, and 444 as shown in Figures 2 and 3. A first set of mirror coils 420 is located at the two axial ends of the confinement chamber 100 and is independently energized from the confinement coils 412, 414 and 416 of the main magnetic system 410. The first set of mirror coils 420 primarily helps to steer and axially contain the FRC 450 during merging and provides equilibrium shaping control during sustainment. The first mirror coil set 420 produces nominally higher magnetic fields (around 0.4 to 0.5 T) than the central confinement field produced by the central confinement coils 412. The second set of mirror coils 430, which includes three compact quasi-dc mirror coils 432, 434 and 436, is located between the formation sections 200 and the diverters 300 and are driven by a common switching power supply. The mirror coils 432, 434 and 436, together with the more compact pulsed mirror plug coils 444 (fed by a capacitive power supply) and the physical constriction 442 form the mirror plugs 440 that provide a narrow low gas conductance path with very high magnetic fields (between 2 to 4 T with risetimes of about 10 to 20 ms). The most compact pulsed mirror coils 444 are of compact radial dimensions, bore of 20 cm and similar length, compared to the meter-plus-scale bore and pancake design of the confinement coils 412, 414 and 416. The purpose of the mirror plugs 440 is

multifold: (1) The coils 432, 434, 436 and 444 tightly bundle and guide the magnetic flux surfaces 452 and end-streaming plasma jets 454 into the remote divertor chambers 300. This assures that the exhaust particles reach the divertors 300 appropriately and that there are continuous flux surfaces 455 that trace from the open field line 452 region of the central FRC 450 all the way to the divertors 300. (2) The physical constrictions 442 in the FRC system 10, through which that the coils 432, 434, 436 and 444 enable passage of the magnetic flux surfaces 452 and plasma jets 454, provide an impediment to neutral gas flow from the plasma guns 350 that sit in the divertors 300. In the same vein, the constrictions 442 prevent back-streaming of gas from the formation sections 200 to the divertors 300 thereby reducing the number of neutral particles that has to be introduced into the entire FRC system 10 when commencing the start up of an FRC. (3) The strong axial mirrors produced by the coils 432, 434, 436 and 444 reduce axial particle losses and thereby reduce the parallel particle diffusivity on open field lines.

#### *Axial Plasma Guns*

[0055] Plasma streams from guns 350 mounted in the divertor chambers 310 of the divertors 300 are intended to improve stability and neutral beam performance. The guns 350 are mounted on axis inside the chamber 310 of the divertors 300 as illustrated in Figures 3 and 10 and produce plasma flowing along the open flux lines 452 in the divertor 300 and towards the center of the confinement chamber 100. The guns 350 operate at a high density gas discharge in a washer-stack channel and are designed to generate several kiloamperes of fully ionized plasma for 5 to 10 ms. The guns 350 include a pulsed magnetic coil that matches the output plasma stream with the desired size of the plasma in the confinement chamber 100. The technical parameters of the guns 350 are characterized by a channel having a 5 to 13 cm outer diameter and up to about 10 cm inner diameter and provide a discharge current of 10-15 kA at 400-600 V with a gun-internal magnetic field of between 0.5 to 2.3 T.

[0056] The gun plasma streams can penetrate the magnetic fields of the mirror plugs 440 and flow into the formation section 200 and confinement chamber 100. The efficiency of plasma transfer through the mirror plug 440 increases with decreasing distance between the gun 350 and the plug 440 and by making the plug 440 wider and shorter. Under reasonable conditions, the guns 350 can each deliver approximately  $10^{22}$  protons/s through the 2 to 4 T mirror plugs 440 with high ion and electron temperatures of about 150 to 300 eV and about 40 to 50 eV, respectively. The guns 350 provide significant refueling of the FRC edge layer 456, and an improved overall FRC particle confinement.

[0057] To further increase the plasma density, a gas box could be utilized to puff additional gas into the plasma stream from the guns 350. This technique allows a several-fold increase in the injected plasma density. In the FRC system 10, a gas box installed on the divertor 300 side of the mirror plugs 440 improves the refueling of the FRC edge layer 456, formation of the FRC 450, and plasma line-tying.

[0058] Given all the adjustment parameters discussed above and also taking into account that operation with just one or both guns is possible, it is readily apparent that a wide spectrum of operating modes is accessible.

#### *Biasing Electrodes*

[0059] Electrical biasing of open flux surfaces can provide radial potentials that give rise to azimuthal  $E \times B$  motion that provides a control mechanism, analogous to turning a knob, to control rotation of the open field line plasma as well as the actual FRC core 450 via velocity shear. To accomplish this control, the FRC system 10 employs various electrodes strategically placed in various parts of the machine. Figure 3 depicts biasing electrodes positioned at preferred locations within the FRC system 10.

[0060] In principle, there are 4 classes of electrodes: (1) point electrodes 905 in the confinement chamber 100 that make contact with particular open field lines 452 in the edge of the FRC 450 to provide local charging, (2) annular electrodes 900 between the confinement chamber 100 and the formation sections 200 to charge far-edge flux layers 456 in an azimuthally symmetric fashion, (3) stacks of concentric electrodes 910 in the divertors 300 to charge multiple concentric flux layers 455 (whereby the selection of layers is controllable by adjusting coils 416 to adjust the divertor magnetic field so as to terminate the desired flux layers 456 on the appropriate electrodes 910), and finally (4) the anodes 920 (see Figure 10) of the plasma guns 350 themselves (which intercept inner open flux surfaces 455 near the separatrix of the FRC 450). Figures 10 and 11 show some typical designs for some of these.

[0061] In all cases these electrodes are driven by pulsed or dc power sources at voltages up to about 800 V. Depending on electrode size and what flux surfaces are intersected, currents can be drawn in the kilo-ampere range.

#### *Un-Sustained Operation of FRC System – Conventional Regime*

[0062] The standard plasma formation on the FRC system 10 follows the well-developed reversed-field-theta-pinch technique. A typical process for starting up an FRC commences by driving the quasi-dc coils 412, 414, 416, 420, 432, 434 and 436 to steady state operation. The RFTP pulsed power circuits of the pulsed power formation systems 210 then drive the pulsed fast reversed magnet

field coils 232 to create a temporary reversed bias of about  $-0.05$  T in the formation sections 200. At this point a predetermined amount of neutral gas at 9-20 psi is injected into the two formation volumes defined by the quartz-tube chambers 240 of the (north and south) formation sections 200 via a set of azimuthally-oriented puff-valves at flanges located on the outer ends of the formation sections 200. Next a small RF ( $\sim$  hundreds of kilo-hertz) field is generated from a set of antennas on the surface of the quartz tubes 240 to create pre-ionization in the form of local seed ionization regions within the neutral gas columns. This is followed by applying a theta-ringing modulation on the current driving the pulsed fast reversed magnet field coils 232, which leads to more global pre-ionization of the gas columns. Finally, the main pulsed power banks of the pulsed power formation systems 210 are fired to drive pulsed fast reversed magnet field coils 232 to create a forward-biased field of up to 0.4 T. This step can be time-sequenced such that the forward-biased field is generated uniformly throughout the length of the formation tubes 240 (static formation) or such that a consecutive peristaltic field modulation is achieved along the axis of the formation tubes 240 (dynamic formation).

[0063] In this entire formation process, the actual field reversal in the plasma occurs rapidly, within about 5  $\mu$ s. The multi-gigawatt pulsed power delivered to the forming plasma readily produces hot FRCs which are then ejected from the formation sections 200 via application of either a time-sequenced modulation of the forward magnetic field (magnetic peristalsis) or temporarily increased currents in the last coils of coil sets 232 near the axial outer ends of the formation tubes 210 (forming an axial magnetic field gradient that points axially towards the confinement chamber 100). The two (north and south) formation FRCs so formed and accelerated then expand into the larger diameter confinement chamber 100, where the quasi-dc coils 412 produce a forward-biased field to control radial expansion and provide the equilibrium external magnetic flux.

[0064] Once the north and south formation FRCs arrive near the midplane of the confinement chamber 100, the FRCs collide. During the collision the axial kinetic energies of the north and south formation FRCs are largely thermalized as the FRCs merge ultimately into a single FRC 450. A large set of plasma diagnostics are available in the confinement chamber 100 to study the equilibria of the FRC 450. Typical operating conditions in the FRC system 10 produce compound FRCs with separatrix radii of about 0.4 m and about 3 m axial extend. Further characteristics are external magnetic fields of about 0.1 T, plasma densities around  $5 \times 10^{19} \text{ m}^{-3}$  and total plasma temperature of up to 1 keV. Without any sustainment, i.e., no heating and/or current drive via neutral beam injection or other auxiliary means, the lifetime of these FRCs is limited to about 1 ms, the indigenous characteristic configuration decay time.

Experimental Data of Unsustained Operation – Conventional Regime

[0065] Figure 12 shows a typical time evolution of the excluded flux radius,  $r_{\Delta\Phi}$ , which approximates the separatrix radius,  $r_s$ , to illustrate the dynamics of the theta-pinch merging process of the FRC 450. The two (north and south) individual plasmoids are produced simultaneously and then accelerated out of the respective formation sections 200 at a supersonic speed,  $v_z \sim 250$  km/s, and collide near the midplane at  $z = 0$ . During the collision the plasmoids compress axially, followed by a rapid radial and axial expansion, before eventually merging to form an FRC 450. Both radial and axial dynamics of the merging FRC 450 are evidenced by detailed density profile measurements and bolometer-based tomography.

[0066] Data from a representative un-sustained discharge of the FRC system 10 are shown as functions of time in Figure 13. The FRC is initiated at  $t = 0$ . The excluded flux radius at the machine's axial mid-plane is shown in Figure 13(a). This data is obtained from an array of magnetic probes, located just inside the confinement chamber's stainless steel wall, that measure the axial magnetic field. The steel wall is a good flux conserver on the time scales of this discharge.

[0067] Line-integrated densities are shown in Figure 13(b), from a 6-chord  $\text{CO}_2/\text{He-Ne}$  interferometer located at  $z = 0$ . Taking into account vertical ( $y$ ) FRC displacement, as measured by bolometric tomography, Abel inversion yields the density contours of Figures 13(c). After some axial and radial sloshing during the first 0.1 ms, the FRC settles with a hollow density profile. This profile is fairly flat, with substantial density on axis, as required by typical 2-D FRC equilibria.

[0068] Total plasma temperature is shown in Figure 13(d), derived from pressure balance and fully consistent with Thomson scattering and spectroscopy measurements.

[0069] Analysis from the entire excluded flux array indicates that the shape of the FRC separatrix (approximated by the excluded flux axial profiles) evolves gradually from racetrack to elliptical. This evolution, shown in Figure 14, is consistent with a gradual magnetic reconnection from two to a single FRC. Indeed, rough estimates suggest that in this particular instant about 10% of the two initial FRC magnetic fluxes reconnects during the collision.

[0070] The FRC length shrinks steadily from 3 down to about 1 m during the FRC lifetime. This shrinkage, visible in Figure 14, suggests that mostly convective energy loss dominates the FRC confinement. As the plasma pressure inside the separatrix decreases faster than the external magnetic pressure, the magnetic field line tension in the end regions compresses the FRC axially, restoring axial and radial equilibrium. For the discharge discussed in Figures 13 and 14, the FRC magnetic flux, particle inventory, and thermal energy (about 10 mWb,  $7 \times 10^{19}$  particles, and 7 kJ, respectively) decrease by roughly an order of magnitude in the first millisecond, when the FRC equilibrium appears to subside.

### Sustained Operation – HPF Regime

[0071] The examples in Figures 12 to 14 are characteristic of decaying FRCs without any sustainment. However, several techniques are deployed on the FRC system 10 to further improve FRC confinement (inner core and edge layer) to the HPF regime and sustain the configuration.

### *Neutral Beams*

[0072] First, fast (H) neutrals are injected perpendicular to  $B_z$  in beams from the eight neutral beam injectors 600. The beams of fast neutrals are injected from the moment the north and south formation FRCs merge in the confinement chamber 100 into one FRC 450. The fast ions, created primarily by charge exchange, have betatron orbits (with primary radii on the scale of the FRC topology or at least much larger than the characteristic magnetic field gradient length scale) that add to the azimuthal current of the FRC 450. After some fraction of the discharge (after 0.5 to 0.8 ms into the shot), a sufficiently large fast ion population significantly improves the inner FRC's stability and confinement properties (*see e.g. M.W. Binderbauer and N. Rostoker, Plasma Phys. 56, part 3, 451 (1996)*). Furthermore, from a sustainment perspective, the beams from the neutral beam injectors 600 are also the primary means to drive current and heat the FRC plasma.

[0073] In the plasma regime of the FRC system 10, the fast ions slow down primarily on plasma electrons. During the early part of a discharge, typical orbit-averaged slowing-down times of fast ions are 0.3 – 0.5 ms, which results in significant FRC heating, primarily of electrons. The fast ions make large radial excursions outside of the separatrix because the internal FRC magnetic field is inherently low (about 0.03 T on average for a 0.1 T external axial field). The fast ions would be vulnerable to charge exchange loss, if the neutral gas density were too high outside of the separatrix. Therefore, wall gettering and other techniques (such as the plasma gun 350 and mirror plugs 440 that contribute, amongst other things, to gas control) deployed on the FRC system 10 tend to minimize edge neutrals and enable the required build-up of fast ion current.

### *Pellet Injection*

[0074] When a significant fast ion population is built up within the FRC 450, with higher electron temperatures and longer FRC lifetimes, frozen H or D pellets are injected into the FRC 450 from the pellet injector 700 to sustain the FRC particle inventory of the FRC 450. The anticipated ablation timescales are sufficiently short to provide a significant FRC particle source. This rate can also be increased by enlarging the surface area of the injected piece by breaking the individual pellet into smaller fragments while in the barrels or injection tubes of the pellet injector 700 and before entering the confinement chamber 100, a step that can be achieved by increasing the friction between the pellet and the walls of the injection tube by tightening the bend radius of the last segment of the

injection tube right before entry into the confinement chamber 100. By virtue of varying the firing sequence and rate of the 12 barrels (injection tubes) as well as the fragmentation, it is possible to tune the pellet injection system 700 to provide just the desired level of particle inventory sustainment. In turn, this helps maintain the internal kinetic pressure in the FRC 450 and sustained operation and lifetime of the FRC 450.

[0075] Once the ablated atoms encounter significant plasma in the FRC 450, they become fully ionized. The resultant cold plasma component is then collisionally heated by the indigenous FRC plasma. The energy necessary to maintain a desired FRC temperature is ultimately supplied by the beam injectors 600. In this sense the pellet injectors 700 together with the neutral beam injectors 600 form the system that maintains a steady state and sustains the FRC 450.

#### *CT Injector*

[0076] As an alternative to the pellet injector, a compact toroid (CT) injector is provided, mainly for fueling field-reversed configuration (FRCs) plasmas. The CT injector 720 comprises a magnetized coaxial plasma-gun (MCPG), which, as shown in Figure 21, includes coaxial cylindrical inner and outer electrodes 722 and 724, a bias coil positioned internal to the inner electrode 726 and an electrical break 728 on an end opposite the discharge of the CT injector 720. Gas is injected through a gas injection port 730 into a space between the inner and outer electrodes 722 and 724 and a Spheromak-like plasma is generated therefrom by discharge and pushed out from the gun by Lorentz force. As shown in Figures 22A and 22B, a pair of CT injectors 720 are coupled to the confinement vessel 100 near and on opposition sides of the mid-plane of the vessel 100 to inject CTs into the central FRC plasma within the confinement vessel 100. The discharge end of the CT injectors 720 are directed towards the mid-plane of the confinement vessel 100 at an angle to the longitudinal axis of the confinement vessel 100 similar to the neutral beam injectors 615.

[0077] In an alternative embodiment, the CT injector 720, as shown in Figures 23A and 23B, include a drift tube 740 comprising an elongate cylindrical tube coupled to the discharge end of the CT injector 720. As depicted, the drift tube 740 includes drift tube coils 742 positioned about and axially spaced along the tube. A plurality of diagnostic ports 744 are depicted along the length of the tube.

[0078] The advantages of the CT injector 720 are: (1) control and adjustability of particle inventory per injected CT; (2) warm plasma is deposited (instead of cryogenic pellets); (3) system can be operated in rep-rate mode so as to allow for continuous fueling; (4) the system can also restore some magnetic flux as the injected CTs carry embedded magnetic field. In an embodiment for experimental use, the inner diameter of an outer electrode is 83.1 mm and the outer diameter of an

inner electrode is 54.0 mm. The surface of the inner electrode 722 is preferably coated with tungsten in order to reduce impurities coming out from the electrode 722. As depicted, the bias coil 726 is mounted inside of the inner electrode 722.

[0079] In recent experiments a supersonic CT translation speed of up to ~100 km/s was achieved. Other typical plasma parameters are as follows: electron density  $\sim 5 \times 10^{21} \text{ m}^{-3}$ , electron temperature ~30-50 eV, and particle inventory of  $\sim 0.5\text{--}1.0 \times 10^{19}$ . The high kinetic pressure of the CT allows the injected plasma to penetrate deeply into the FRC and deposit the particles inside the separatrix. In recent experiments FRC particle fueling has resulted in ~10-20% of the FRC particle inventory being provide by the CT injectors successfully demonstrating fueling can readily be carried out without disrupting the FRC plasma.

#### *Saddle Coils*

[0080] To achieve steady state current drive and maintain the required ion current it is desirable to prevent or significantly reduce electron spin up due to the electron-ion frictional force (resulting from collisional ion electron momentum transfer). The FRC system 10 utilizes an innovative technique to provide electron breaking via an externally applied static magnetic dipole or quadrupole field. This is accomplished via the external saddle coils 460 depicted in Figure 15. The transverse applied radial magnetic field from the saddle coils 460 induces an axial electric field in the rotating FRC plasma. The resultant axial electron current interacts with the radial magnetic field to produce an azimuthal breaking force on the electrons,  $F_{\theta} = -\sigma V_{e\theta} \langle |B_r|^2 \rangle$ . For typical conditions in the FRC system 10, the required applied magnetic dipole (or quadrupole) field inside the plasma needs to be only of order 0.001 T to provide adequate electron breaking. The corresponding external field of about .015 T is small enough to not cause appreciable fast particle losses or otherwise negatively impact confinement. In fact, the applied magnetic dipole (or quadrupole) field contributes to suppress instabilities. In combination with tangential neutral beam injection and axial plasma injection, the saddle coils 460 provide an additional level of control with regards to current maintenance and stability.

#### *Mirror Plugs*

[0081] The design of the pulsed coils 444 within the mirror plugs 440 permits the local generation of high magnetic fields (2 to 4 T) with modest (about 100 kJ) capacitive energy. For formation of magnetic fields typical of the present operation of the FRC system 10, all field lines within the formation volume are passing through the constrictions 442 at the mirror plugs 440, as suggested by the magnetic field lines in Figure 2 and plasma wall contact does not occur. Furthermore, the mirror plugs 440 in tandem with the quasi-dc divertor magnets 416 can be adjusted so to guide the field

lines onto the divertor electrodes 910, or flare the field lines in an end cusp configuration (not shown). The latter improves stability and suppresses parallel electron thermal conduction.

[0082] The mirror plugs 440 by themselves also contribute to neutral gas control. The mirror plugs 440 permit a better utilization of the deuterium gas puffed in to the quartz tubes during FRC formation, as gas back-streaming into the divertors 300 is significantly reduced by the small gas conductance of the plugs (a meager 500 L/s). Most of the residual puffed gas inside the formation tubes 210 is quickly ionized. In addition, the high-density plasma flowing through the mirror plugs 440 provides efficient neutral ionization hence an effective gas barrier. As a result, most of the neutrals recycled in the divertors 300 from the FRC edge layer 456 do not return to the confinement chamber 100. In addition, the neutrals associated with the operation of the plasma guns 350 (as discussed below) will be mostly confined to the divertors 300.

[0083] Finally, the mirror plugs 440 tend to improve the FRC edge layer confinement. With mirror ratios (plug/confinement magnetic fields) in the range 20 to 40, and with a 15 m length between the north and south mirror plugs 440, the edge layer particle confinement time  $\tau_{\parallel}$  increases by up to an order of magnitude. Improving  $\tau_{\parallel}$  readily increases the FRC particle confinement.

[0084] Assuming radial diffusive (D) particle loss from the separatrix volume 453 balanced by axial loss ( $\tau_{\parallel}$ ) from the edge layer 456, one obtains  $(2\pi r_s L_s)(D n_s / \delta) = (2\pi r_s L_s \delta)(n_s / \tau_{\parallel})$ , from which the separatrix density gradient length can be rewritten as  $\delta = (D \tau_{\parallel})^{1/2}$ . Here  $r_s$ ,  $L_s$  and  $n_s$  are separatrix radius, separatrix length and separatrix density, respectively. The FRC particle confinement time is  $\tau_N = [\pi r_s^2 L_s \langle n \rangle] / [(2\pi r_s L_s)(D n_s / \delta)] = (\langle n \rangle / n_s)(\tau_{\perp} \tau_{\parallel})^{1/2}$ , where  $\tau_{\perp} = a^2 / D$  with  $a = r_s / 4$ . Physically, improving  $\tau_{\parallel}$  leads to increased  $\delta$  (reduced separatrix density gradient and drift parameter), and, therefore, reduced FRC particle loss. The overall improvement in FRC particle confinement is generally somewhat less than quadratic because  $n_s$  increases with  $\tau_{\parallel}$ .

[0085] A significant improvement in  $\tau_{\parallel}$  also requires that the edge layer 456 remains grossly stable (i.e., no  $n = 1$  flute, firehose, or other MHD instability typical of open systems). Use of the plasma guns 350 provides for this preferred edge stability. In this sense, the mirror plugs 440 and plasma gun 350 form an effective edge control system.

### *Plasma Guns*

[0086] The plasma guns 350 improve the stability of the FRC exhaust jets 454 by line-tying. The gun plasmas from the plasma guns 350 are generated without azimuthal angular momentum, which proves useful in controlling FRC rotational instabilities. As such the guns 350 are an effective means to control FRC stability without the need for the older quadrupole stabilization technique. As a result, the plasma guns 350 make it possible to take advantage of the beneficial effects of fast

particles or access the advanced hybrid kinetic FRC regime as outlined in this disclosure. Therefore, the plasma guns 350 enable the FRC system 10 to be operated with saddle coil currents just adequate for electron breaking but below the threshold that would cause FRC instability and/or lead to dramatic fast particle diffusion.

[0087] As mentioned in the *Mirror Plug* discussion above, if  $\tau_{\parallel}$  can be significantly improved, the supplied gun plasma would be comparable to the edge layer particle loss rate ( $\sim 10^{22}$  /s). The lifetime of the gun-produced plasma in the FRC system 10 is in the millisecond range. Indeed, consider the gun plasma with density  $n_e \sim 10^{13}$  cm<sup>-3</sup> and ion temperature of about 200 eV, confined between the end mirror plugs 440. The trap length L and mirror ratio R are about 15 m and 20, respectively. The ion mean free path due to Coulomb collisions is  $\lambda_{ii} \sim 6 \times 10^3$  cm and, since  $\lambda_{ii} \ln R / R < L$ , the ions are confined in the gas-dynamic regime. The plasma confinement time in this regime is  $\tau_{gd} \sim RL/2V_s \sim 2$  ms, where  $V_s$  is the ion sound speed. For comparison, the classical ion confinement time for these plasma parameters would be  $\tau_c \sim 0.5\tau_{ii}(\ln R + (\ln R)^{0.5}) \sim 0.7$  ms. The anomalous transverse diffusion may, in principle, shorten the plasma confinement time. However, in the FRC system 10, if we assume the Bohm diffusion rate, the estimated transverse confinement time for the gun plasma is  $\tau_{\perp} > \tau_{gd} \sim 2$  ms. Hence, the guns would provide significant refueling of the FRC edge layer 456, and an improved overall FRC particle confinement.

[0088] Furthermore, the gun plasma streams can be turned on in about 150 to 200 microseconds, which permits use in FRC start-up, translation, and merging into the confinement chamber 100. If turned on around  $t \sim 0$  (FRC main bank initiation), the gun plasmas help to sustain the present dynamically formed and merged FRC 450. The combined particle inventories from the formation FRCs and from the guns is adequate for neutral beam capture, plasma heating, and long sustainment. If turned on at  $t$  in the range -1 to 0 ms, the gun plasmas can fill the quartz tubes 210 with plasma or ionize the gas puffed into the quartz tubes, thus permitting FRC formation with reduced or even perhaps zero puffed gas. The latter may require sufficiently cold formation plasma to permit fast diffusion of the reversed bias magnetic field. If turned on at  $t < -2$  ms, the plasma streams could fill the about 1 to 3 m<sup>3</sup> field line volume of the formation and confinement regions of the formation sections 200 and confinement chamber 100 with a target plasma density of a few  $10^{13}$  cm<sup>-3</sup>, sufficient to allow neutral beam build-up prior to FRC arrival. The formation FRCs could then be formed and translated into the resulting confinement vessel plasma. In this way the plasma guns 350 enable a wide variety of operating conditions and parameter regimes.

### *Electrical Biasing*

[0089] Control of the radial electric field profile in the edge layer 456 is beneficial in various ways to FRC stability and confinement. By virtue of the innovative biasing components deployed in the FRC system 10 it is possible to apply a variety of deliberate distributions of electric potentials to a group of open flux surfaces throughout the machine from areas well outside the central confinement region in the confinement chamber 100. In this way radial electric fields can be generated across the edge layer 456 just outside of the FRC 450. These radial electric fields then modify the azimuthal rotation of the edge layer 456 and effect its confinement via  $E \times B$  velocity shear. Any differential rotation between the edge layer 456 and the FRC core 453 can then be transmitted to the inside of the FRC plasma by shear. As a result, controlling the edge layer 456 directly impacts the FRC core 453. Furthermore, since the free energy in the plasma rotation can also be responsible for instabilities, this technique provides a direct means to control the onset and growth of instabilities. In the FRC system 10, appropriate edge biasing provides an effective control of open field line transport and rotation as well as FRC core rotation. The location and shape of the various provided electrodes 900, 905, 910 and 920 allows for control of different groups of flux surfaces 455 and at different and independent potentials. In this way a wide array of different electric field configurations and strengths can be realized, each with different characteristic impact on plasma performance.

[0090] A key advantage of all these innovative biasing techniques is the fact that core and edge plasma behavior can be effected from well outside the FRC plasma, i.e. there is no need to bring any physical components in touch with the central hot plasma (which would have severe implications for energy, flux and particle losses). This has a major beneficial impact on performance and all potential applications of the HPF concept.

### *Experimental Data – HPF Operation*

[0091] Injection of fast particles via beams from the neutral beam guns 600 plays an important role in enabling the HPF regime. Figure 16 illustrates this fact. Depicted is a set of curves showing how the FRC lifetime correlates with the length of the beam pulses. All other operating conditions are held constant for all discharges comprising this study. The data is averaged over many shots and, therefore, represents typical behavior. It is clearly evident that longer beam duration produces longer lived FRCs. Looking at this evidence as well as other diagnostics during this study, it demonstrates that beams increase stability and reduce losses. The correlation between beam pulse length and FRC lifetime is not perfect as beam trapping becomes inefficient below a certain plasma size, i.e., as the FRC 450 shrinks in physical size not all of the injected beams are intercepted and trapped. Shrinkage of the FRC is primarily due to the fact that net energy loss ( $\sim 4$  MW about midway through the

discharge) from the FRC plasma during the discharge is somewhat larger than the total power fed into the FRC via the neutral beams (~2.5 MW) for the particular experimental setup. Locating the beams at a location closer to the mid-plane of the vessel 100 would tend to reduce these losses and extend FRC lifetime.

[0092] Figure 17 illustrates the effects of different components to achieve the HPF regime. It shows a family of typical curves depicting the lifetime of the FRC 450 as a function of time. In all cases a constant, modest amount of beam power (about 2.5 MW) is injected for the full duration of each discharge. Each curve is representative of a different combination of components. For example, operating the FRC system 10 without any mirror plugs 440, plasma guns 350 or gettering from the gettering systems 800 results in rapid onset of rotational instability and loss of the FRC topology. Adding only the mirror plugs 440 delays the onset of instabilities and increases confinement. Utilizing the combination of mirror plugs 440 and a plasma gun 350 further reduces instabilities and increases FRC lifetime. Finally adding gettering (Ti in this case) on top of the gun 350 and plugs 440 yields the best results – the resultant FRC is free of instabilities and exhibits the longest lifetime. It is clear from this experimental demonstration that the full combination of components produces the best effect and provides the beams with the best target conditions.

[0093] As shown in Figure 1, the newly discovered HPF regime exhibits dramatically improved transport behavior. Figure 1 illustrates the change in particle confinement time in the FRC system 10 between the conventionally regime and the HPF regime. As can be seen, it has improved by well over a factor of 5 in the HPF regime. In addition, Figure 1 details the particle confinement time in the FRC system 10 relative to the particle confinement time in prior conventional FRC experiments. With regards to these other machines, the HPF regime of the FRC system 10 has improved confinement by a factor of between 5 and close to 20. Finally and most importantly, the nature of the confinement scaling of the FRC system 10 in the HPF regime is dramatically different from all prior measurements. Before the establishment of the HPF regime in the FRC system 10, various empirical scaling laws were derived from data to predict confinement times in prior FRC experiments. All those scaling rules depend mostly on the ratio  $R^2/\rho_i$ , where  $R$  is the radius of the magnetic field null (a loose measure of the physical scale of the machine) and  $\rho_i$  is the ion larmor radius evaluated in the externally applied field (a loose measure of the applied magnetic field). It is clear from Figure 1 that long confinement in conventional FRCs is only possible at large machine size and/or high magnetic field. Operating the FRC system 10 in the conventional FRC regime CR tends to follow those scaling rules, as indicated in Figure 1. However, the HPF regime is vastly superior and shows that much better confinement is attainable without large machine size or high magnetic fields. More importantly, it is also clear from Figure 1 that the HPF regime results in

improved confinement time with reduced plasma size as compared to the CR regime. Similar trends are also visible for flux and energy confinement times, as described below, which have increased by over a factor of 3-8 in the FRC system 10 as well. The breakthrough of the HPF regime, therefore, enables the use of modest beam power, lower magnetic fields and smaller size to sustain and maintain FRC equilibria in the FRC system 10 and future higher energy machines. Hand-in-hand with these improvements comes lower operating and construction costs as well as reduced engineering complexity.

[0094] For further comparison, Figure 18 shows data from a representative HPF regime discharge in the FRC system 10 as a function of time. Figure 18(a) depicts the excluded flux radius at the mid-plane. For these longer timescales the conducting steel wall is no longer as good a flux conserver and the magnetic probes internal to the wall are augmented with probes outside the wall to properly account for magnetic flux diffusion through the steel. Compared to typical performance in the conventional regime CR, as shown in Figure 13, the HPF regime operating mode exhibits over 400% longer lifetime.

[0095] A representative cord of the line integrated density trace is shown in Figure 18(b) with its Abel inverted complement, the density contours, in Figure 18(c). Compared to the conventional FRC regime CR, as shown in Figure 13, the plasma is more quiescent throughout the pulse, indicative of very stable operation. The peak density is also slightly lower in HPF shots – this is a consequence of the hotter total plasma temperature (up to a factor of 2) as shown in Figure 18(d).

[0096] For the respective discharge illustrated in Figure 18, the energy, particle and flux confinement times are 0.5 ms, 1 ms and 1 ms, respectively. At a reference time of 1 ms into the discharge, the stored plasma energy is 2 kJ while the losses are about 4 MW, making this target very suitable for neutral beam sustainment.

[0097] Figure 19 summarizes all advantages of the HPF regime in the form of a newly established experimental HPF flux confinement scaling. As can be seen in Figure 19, based on measurements taken before and after  $t = 0.5$  ms, i.e.,  $t \leq 0.5$  ms and  $t > 0.5$  ms, the flux confinement (and similarly, particle confinement and energy confinement) scales with roughly the square of the electron Temperature ( $T_e$ ) for a given separatrix radius ( $r_s$ ). This strong scaling with a positive power of  $T_e$  (and not a negative power) is completely opposite to that exhibited by conventional tokomaks, where confinement is typically inversely proportional to some power of the electron temperature. The manifestation of this scaling is a direct consequence of the HPF state and the large orbit (i.e. orbits on the scale of the FRC topology and/or at least the characteristic magnetic field gradient length scale) ion population. Fundamentally, this new scaling substantially favors high operating temperatures and enables relatively modest sized reactors.

[0098] With the advantages the HPF regime presents, FRC sustainment or steady state driven by neutral beams and using appropriate pellet injection is achievable, meaning global plasma parameters such as plasma thermal energy, total particle numbers, plasma radius and length as well as magnetic flux are sustainable at reasonable levels without substantial decay. For comparison, Figure 20 shows data in plot A from a representative HPF regime discharge in the FRC system 10 as a function of time and in plot B for a projected representative HPF regime discharge in the FRC system 10 as a function of time where the FRC 450 is sustained without decay through the duration of the neutral beam pulse. For plot A, neutral beams with total power in the range of about 2.5-2.9 MW were injected into the FRC 450 for an active beam pulse length of about 6 ms. The plasma diamagnetic lifetime depicted in plot A was about 5.2 ms. More recent data shows a plasma diamagnetic lifetime of about 7.2 ms is achievable with an active beam pulse length of about 7 ms.

[0099] As noted above with regard to Figure 16, the correlation between beam pulse length and FRC lifetime is not perfect as beam trapping becomes inefficient below a certain plasma size, i.e., as the FRC 450 shrinks in physical size not all of the injected beams are intercepted and trapped. Shrinkage or decay of the FRC is primarily due to the fact that net energy loss (- 4 MW about midway through the discharge) from the FRC plasma during the discharge is somewhat larger than the total power fed into the FRC via the neutral beams (-2.5 MW) for the particular experimental setup. As noted with regard to Figure 3C, angled beam injection from the neutral beam guns 600 towards the mid-plane improves beam-plasma coupling, even as the FRC plasma shrinks or otherwise axially contracts during the injection period. In addition, appropriate pellet fueling will maintain the requisite plasma density.

[00100] Plot B is the result of simulations run using an active beam pulse length of about 6 ms and total beam power from the neutral beam guns 600 of slightly more than about 10 MW, where neutral beams shall inject H (or D) neutrals with particle energy of about 15 keV. The equivalent current injected by each of the beams is about 110 A. For plot B, the beam injection angle to the device axis was about 20°, target radius 0.19 m. Injection angle can be changed within the range 15° - 25°. The beams are to be injected in the co-current direction azimuthally. The net side force as well as net axial force from the neutral beam momentum injection shall be minimized. As with plot A, fast (H) neutrals are injected from the neutral beam injectors 600 from the moment the north and south formation FRCs merge in the confinement chamber 100 into one FRC 450.

[00101] The simulations that where the foundation for plot B use multi-dimensional hall-MHD solvers for the background plasma and equilibrium, fully kinetic Monte-Carlo based solvers for the energetic beam components and all scattering processes, as well as a host of coupled transport

equations for all plasma species to model interactive loss processes. The transport components are empirically calibrated and extensively benchmarked against an experimental database.

[00102] As shown by plot B, the steady state diamagnetic lifetime of the FRC 450 will be the length of the beam pulse. However, it is important to note that the key correlation plot B shows is that when the beams are turned off the plasma or FRC begins to decay at that time, but not before. The decay will be similar to that which is observed in discharges which are not beam-assisted - probably on order of 1 ms beyond the beam turn off time - and is simply a reflection of the characteristic decay time of the plasma driven by the intrinsic loss processes.

[00103] While the invention is susceptible to various modifications, and alternative forms, specific examples thereof have been shown in the drawings and are herein described in detail. It should be understood, however, that the invention is not to be limited to the particular forms or methods disclosed, but to the contrary, the invention is to cover all modifications, equivalents and alternatives falling within the spirit and scope of the appended claims.

[00104] In the description above, for purposes of explanation only, specific nomenclature is set forth to provide a thorough understanding of the present disclosure. However, it will be apparent to one skilled in the art that these specific details are not required to practice the teachings of the present disclosure.

[00105] It is also expressly noted that all value ranges or indications of groups of entities disclose every possible intermediate value or intermediate entity for the purpose of original disclosure, as well as for the purpose of restricting the claimed subject matter.

[00106] Systems and methods for generating and maintaining an HPF regime FRC have been disclosed. It is understood that the embodiments described herein are for the purpose of elucidation and should not be considered limiting the subject matter of the disclosure. Various modifications, uses, substitutions, combinations, improvements, methods of productions without departing from the scope or spirit of the present invention would be evident to a person skilled in the art. For example, the reader is to understand that the specific ordering and combination of process actions described herein is merely illustrative, unless otherwise stated, and the invention can be performed using different or additional process actions, or a different combination or ordering of process actions. As another example, each feature of one embodiment can be mixed and matched with other features shown in other embodiments. Features and processes known to those of ordinary skill may similarly be incorporated as desired. Additionally and obviously, features may be added or subtracted as

desired. Accordingly, the invention is not to be restricted except in light of the attached claims and their equivalents.

CLAIMS:

1. A method for generating and maintaining a magnetic field with a field reversed configuration (FRC) comprising the steps of:  
  
forming an FRC about a plasma in a confinement chamber, and  
  
maintaining the FRC at or about a constant value without decay by injecting beams of neutral atoms from neutral beam injectors into the FRC plasma at an angle towards a mid-plane of the confinement chamber and injecting a compact toroid plasma into the FRC.
2. The method of claim 1 further comprising the step of generating a magnetic field within the chamber with quasi-dc coils extending about the chamber.
3. The method according to any one of claims 1 and 2 further comprising the step of generating a mirror magnetic field within opposing ends of the chamber with quasi-dc mirror coils extending about the opposing ends of the chamber.
4. The method according to any one of claims 1 through 3 wherein the step of the forming the FRC includes forming a formation FRC in a formation section coupled to an end of the confinement chamber and accelerating the formation FRC towards the mid-plane of the chamber to form the FRC.
5. The method of claim 4 wherein the step of the forming the FRC includes forming a second formation FRC in a second formation section coupled to a second end of the confinement chamber and accelerating the second formation FRC towards the mid-plane of the chamber where the two formation FRCs merge to form the FRC.
6. The method according to any one of claims 4 and 5 wherein the step of forming the FRC includes one of forming the formation FRC while accelerating the formation FRC towards the mid-plane of the chamber and forming the formation FRC then accelerating the formation FRC towards the mid-plane of the chamber.
7. The method of claim 5 further comprising the step of guiding magnetic flux surfaces of the FRC into diverters coupled to the ends of the formation sections.
8. The method of claim 4 further comprising the step of guiding magnetic flux surfaces of the FRC into a diverter coupled to the end of the formation section.

9. The method of claim 8 further comprising the step of guiding magnetic flux surfaces of the FRC into a second diverter coupled to the end of the chamber opposite the formation section.

10. The method according to any one of claims 7 through 9 further comprising the step of generating a magnetic field within the formation sections and diverters with quasi-dc coils extending about the formation sections and diverters.

11. The method according to any one of claims 7 and 10 further comprising the step of generating a mirror magnetic field between the formation sections and the diverters with quasi-dc mirror coils.

12. The method of claim 11 further comprising step of generating a mirror plug magnetic field within a constriction between the formation sections and the diverters with quasi-dc mirror plug coils extending about the constriction between the formation sections and the diverters.

13. The method according to any one of claims 1 through 12 further comprising the step of generating one of a magnetic dipole field and a magnetic quadrupole field within the chamber with saddle coils coupled to the chamber.

14. The method according to any one of claims 1 through 13 further comprising the step of conditioning the internal surfaces of the chamber, formation sections, and diverters with a gettering system.

15. The method of claim 14 wherein the gettering system includes one of a Titanium deposition system and a Lithium deposition system.

16. The method according to any one of claims 1 through 15 further comprising the step of axially injecting plasma into the FRC from axially mounted plasma guns.

17. The method according to any one of claims 1 through 16 further comprising the step of controlling a radial electric field profile in an edge layer of the FRC.

18. The method of claim 17 wherein the step of controlling the radial electric field profile in an edge layer of the FRC includes applying a distribution of electric potential to a group of open flux surfaces of the FRC with biasing electrodes.

19. A system for generating and maintaining a magnetic field with a field reversed configuration (FRC) comprising

a confinement chamber,

first and second diametrically opposed FRC formation sections coupled to the confinement chamber, the formation section comprising modularized formation systems for generating an FRC and translating the FRC toward a midplane of the confinement chamber,

first and second divertors coupled to the first and second formation sections,

first and second axial plasma guns operably coupled to the first and second divertors, the first and second formation sections and the confinement chamber,

a plurality of neutral atom beam injectors coupled to the confinement chamber and oriented to inject neutral atom beams toward a mid-plane of the confinement chamber at an angle less than normal to a longitudinal axis of the confinement chamber,

a magnetic system comprising a plurality of quasi-dc coils positioned around the confinement chamber, the first and second formation sections, and the first and second divertors, first and second set of quasi-dc mirror coils positioned between the confinement chamber and the first and second formation sections, and first and second mirror plugs positioned between the first and second formation sections and the first and second divertors,

a gettering system coupled to the confinement chamber and the first and second divertors,

one or more biasing electrodes for electrically biasing open flux surface of a generated FRC, the one or more biasing electrodes being positioned within one or more of the confinement chamber, the first and second formation sections, and the first and second divertors,

two or more saddle coils coupled to the confinement chamber, and

a CT injector coupled to the confinement chamber.

20. The system of claim 19 wherein the system is configured to generate an FRC and maintain the FRC at or about a constant value without decay while neutral atom beams are injected into the FRC.

21. The system of claim 19 wherein the mirror plug comprises third and fourth set of mirror coils between each of the first and second formation sections and the first and second divertors.

22. The system according to any one of claims 19 and 20 wherein the mirror plug further comprises a set of mirror plug coils wrapped around a constriction in the passageway between each of the first and second formation sections and the first and second divertors.

23. The system according to any one of claims 19-22 wherein the first and second diametrically opposed FRC formation sections comprise an elongate tube, wherein the elongate tube is a quartz tube with a quartz liner.

24. The system according to any one of claims 19-23 wherein the formation systems are pulsed power formation systems.

25. The system according to any one of claims 19-22 wherein the formation systems comprise an elongate tube and a plurality of power and control units coupled to individual ones of a plurality of strap assemblies to energize a set of coils of the individual ones of the plurality of strap assemblies wrapped around the elongate tube of the first and second formation sections.

26. The system of claim 25 wherein individual ones of the plurality of power and control units comprising a trigger and control system.

27. The system of claim 26 wherein the trigger and control systems of the individual ones of the plurality of power and control units being synchronizable to enable static FRC formation wherein the FRC is formed and then injected or dynamic FRC formation wherein the FRC is formed and translated simultaneously.

28. The system according to any one of claims 19-27 wherein the plurality of neutral atom beam injectors comprises one or more RF plasma source neutral atom beam injectors and one or more arc source neutral atom beam injectors.

29. The system according to any one of claims 19-28 wherein the plurality of neutral atom beam injectors are oriented with an injection path tangential to the FRC with a target trapping zone within separatrix of the FRC.

30. The system according to any one of claims 19-29 wherein the gettering system comprises one or more of a Titanium deposition system and a Lithium deposition system that coat the plasma facing surfaces of the confine chamber and the first and second divertors.

31. The system according to any one of claims 19-30 wherein the one or more biasing electrodes includes one or more of one or more point electrodes positioned within the containment chamber to contact open field lines, a set of annular electrodes between the confinement chamber and the first and second formation sections to charge far-edge flux layers in an azimuthally symmetric fashion, a plurality of concentric stacked electrodes positioned in the first and second divertors to charge multiple concentric flux layers, and anodes of the plasma guns to intercept open flux.

32. A system for generating and maintaining a magnetic field with a field reversed configuration (FRC) comprising

a confinement chamber,

first and second diametrically opposed FRC formation sections coupled to the confinement chamber,

first and second divertors coupled to the first and second formation sections,

one or more of a plurality of plasma guns, one or more biasing electrodes and first and second mirror plugs, wherein the plurality of plasma guns includes first and second axial plasma guns operably coupled to the first and second divertors, the first and second formation sections and the confinement chamber, wherein the one or more biasing electrodes being positioned within one or more of the confinement chamber, the first and second formation sections, and the first and second divertors, and wherein the first and second mirror plugs being positioned between the first and second formation sections and the first and second divertors,

a gettering system coupled to the confinement chamber and the first and second divertors,

a plurality of neutral atom beam injectors coupled to the confinement chamber and oriented normal to the axis of the confinement chamber,

a magnetic system comprising a plurality of quasi-dc coils positioned around the confinement chamber, the first and second formation sections, and the first and second divertors,

first and second set of quasi-dc mirror coils positioned between the confinement chamber and the first and second formation sections, and

a CT injector coupled to the confinement chamber,

wherein the system is configured to generate an FRC and maintain the FRC without decay while the neutral beams are injected into the plasma.

33. The system of claim 32 wherein the system is configured to generate an FRC and maintain the FRC at or about a constant value without decay while neutral atom beams are injected into the FRC.

34. The system according to any one of claims 32 and 33 wherein the mirror plug comprises third and fourth sets of mirror coils between each of the first and second formation sections and the first and second divertors.

35. The system according to any one of claims 32-34 wherein the mirror plug further comprises a set of mirror plug coils wrapped around a constriction in the passageway between each of the first and second formation sections and the first and second divertors.

36. The system according to any one of claims 32-35 further comprising first and second axial plasma guns operably coupled to the first and second divertors, the first and second formation sections and the confinement chamber.

37. The system according to any one of claims 32-36 further comprising two or more saddle coils coupled to the confinement chamber.

38. The system according to any one of claims 32-37 wherein the formation section comprises modularized formation systems for generating an FRC and translating it toward a midplane of the confinement chamber.

39. The system according to any one of claims 32-38 wherein the one or more biasing electrodes includes one or more of one or more point electrodes positioned within the containment chamber to contact open field lines, a set of annular electrodes between the confinement chamber and the first and second formation sections to charge far-edge flux layers in an azimuthally symmetric fashion, a plurality of concentric stacked electrodes positioned in the first and second divertors to charge multiple concentric flux layers, and anodes of the plasma guns to intercept open flux .

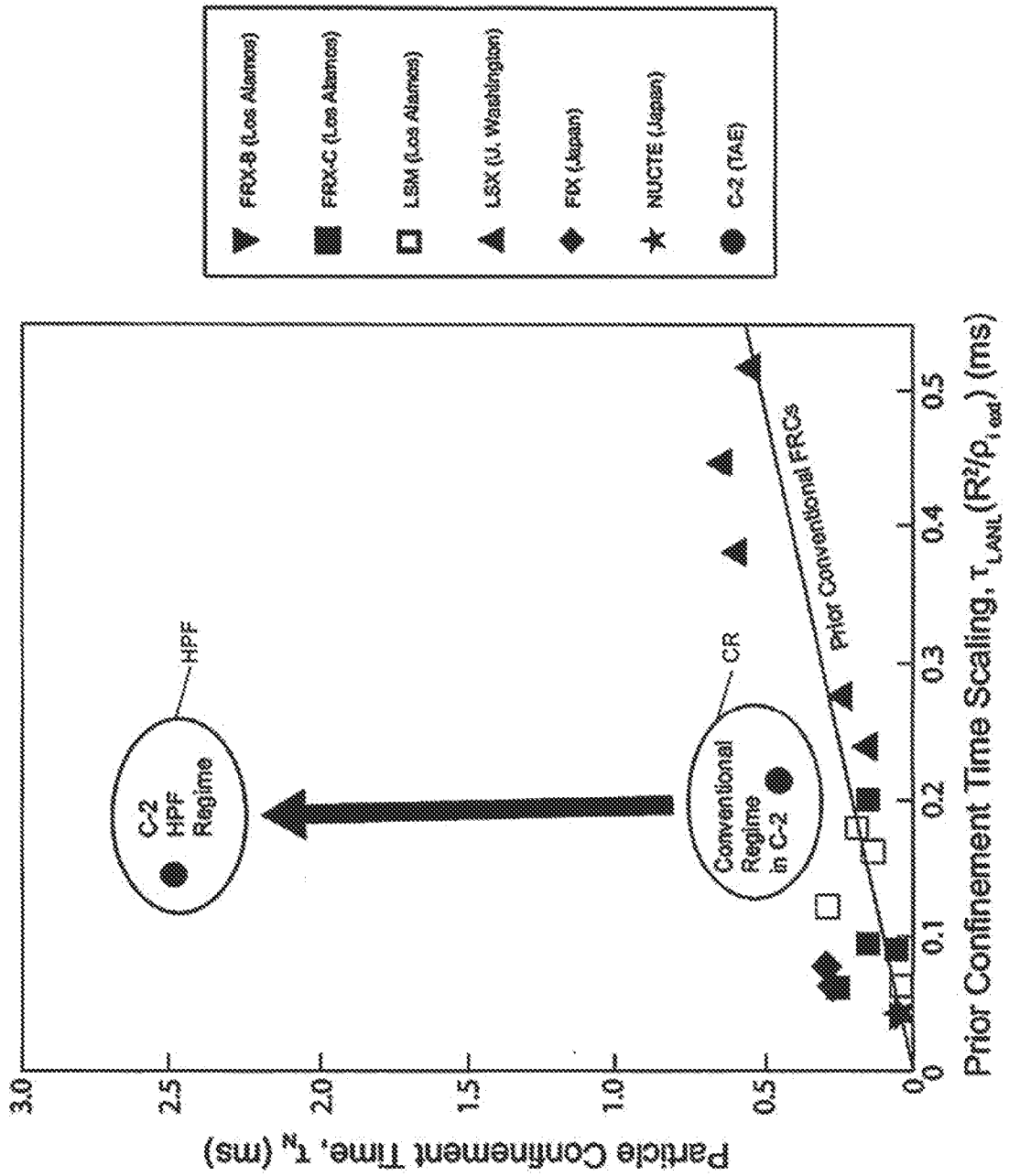

FIGURE 1

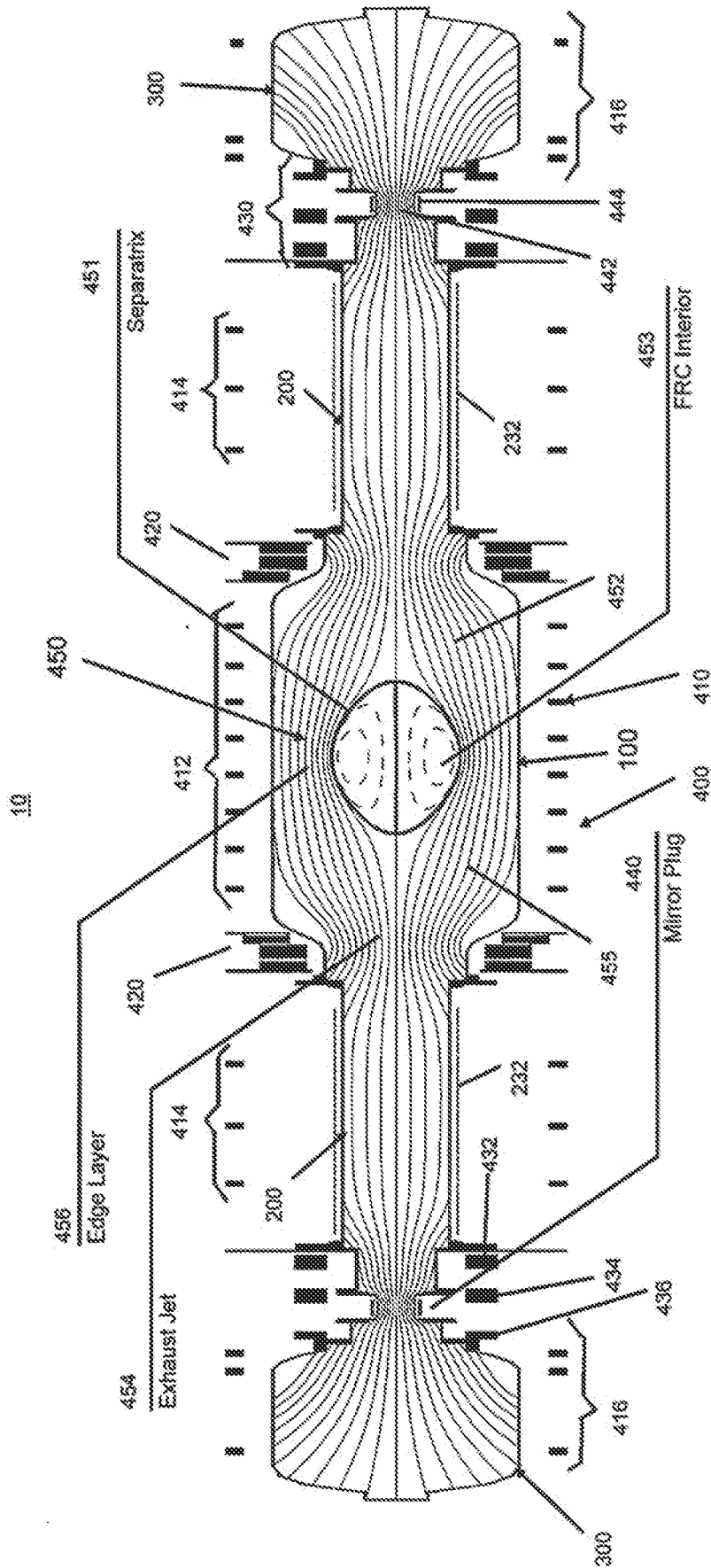

FIGURE 2

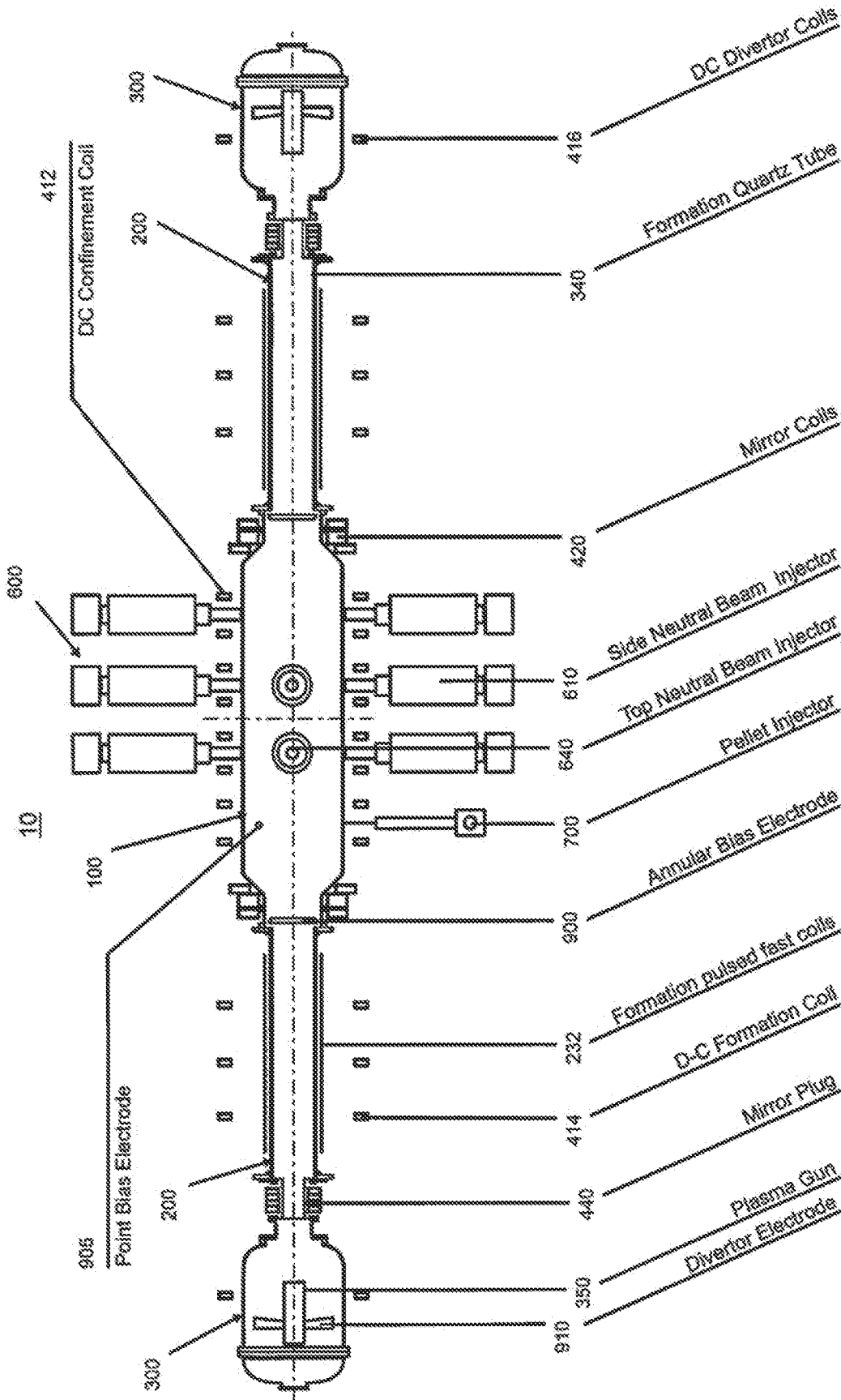

FIGURE 3A

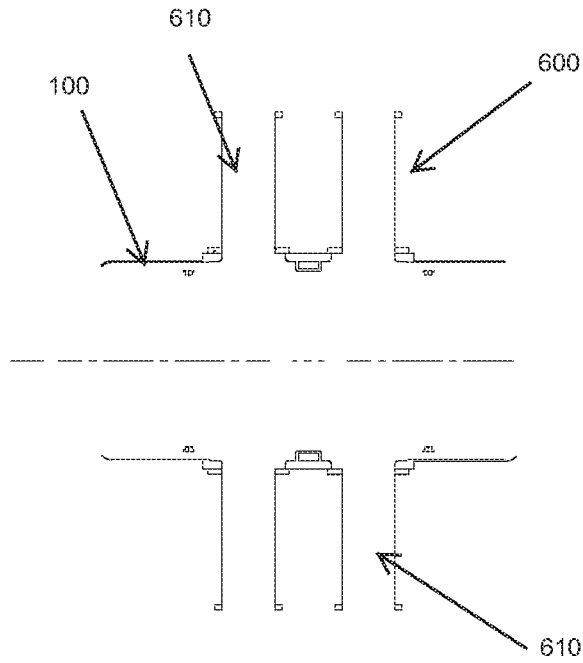

FIGURE 3B

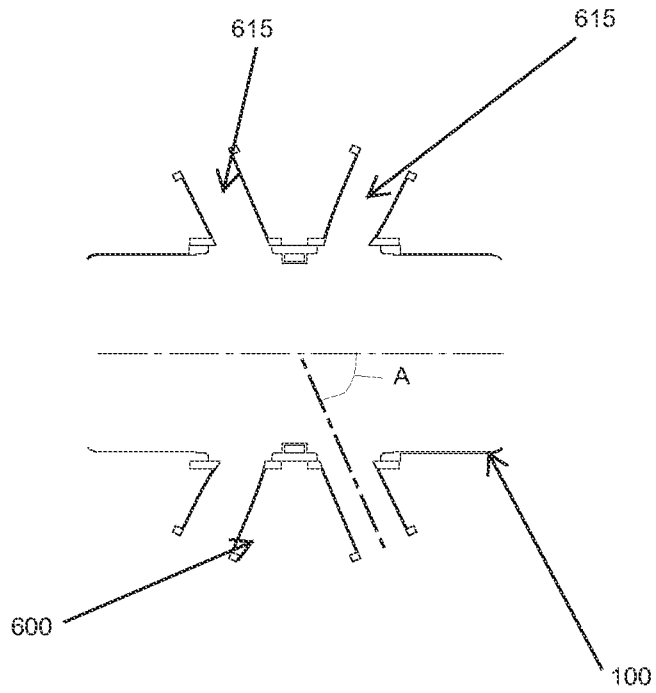

FIGURE 3C

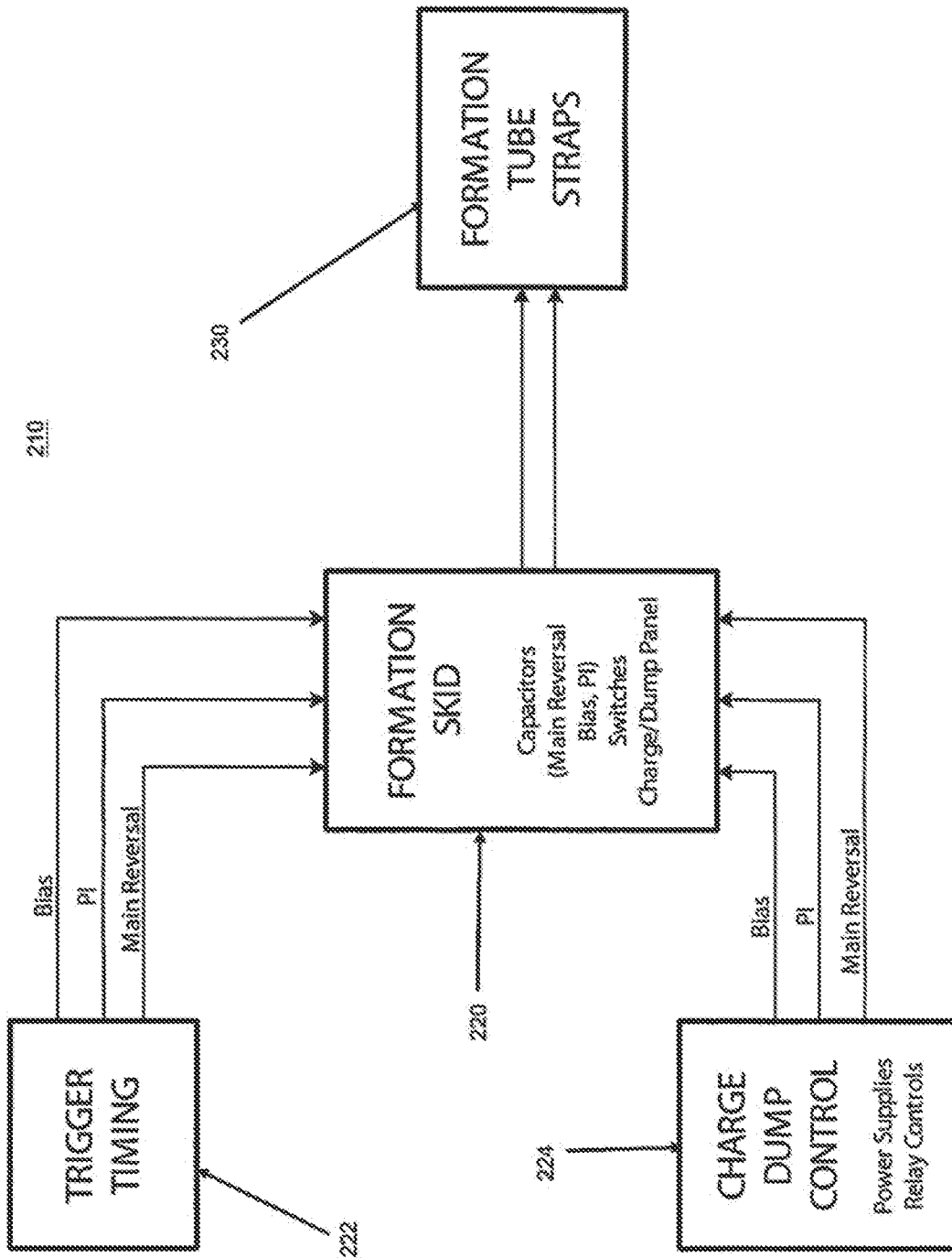

FIGURE 4

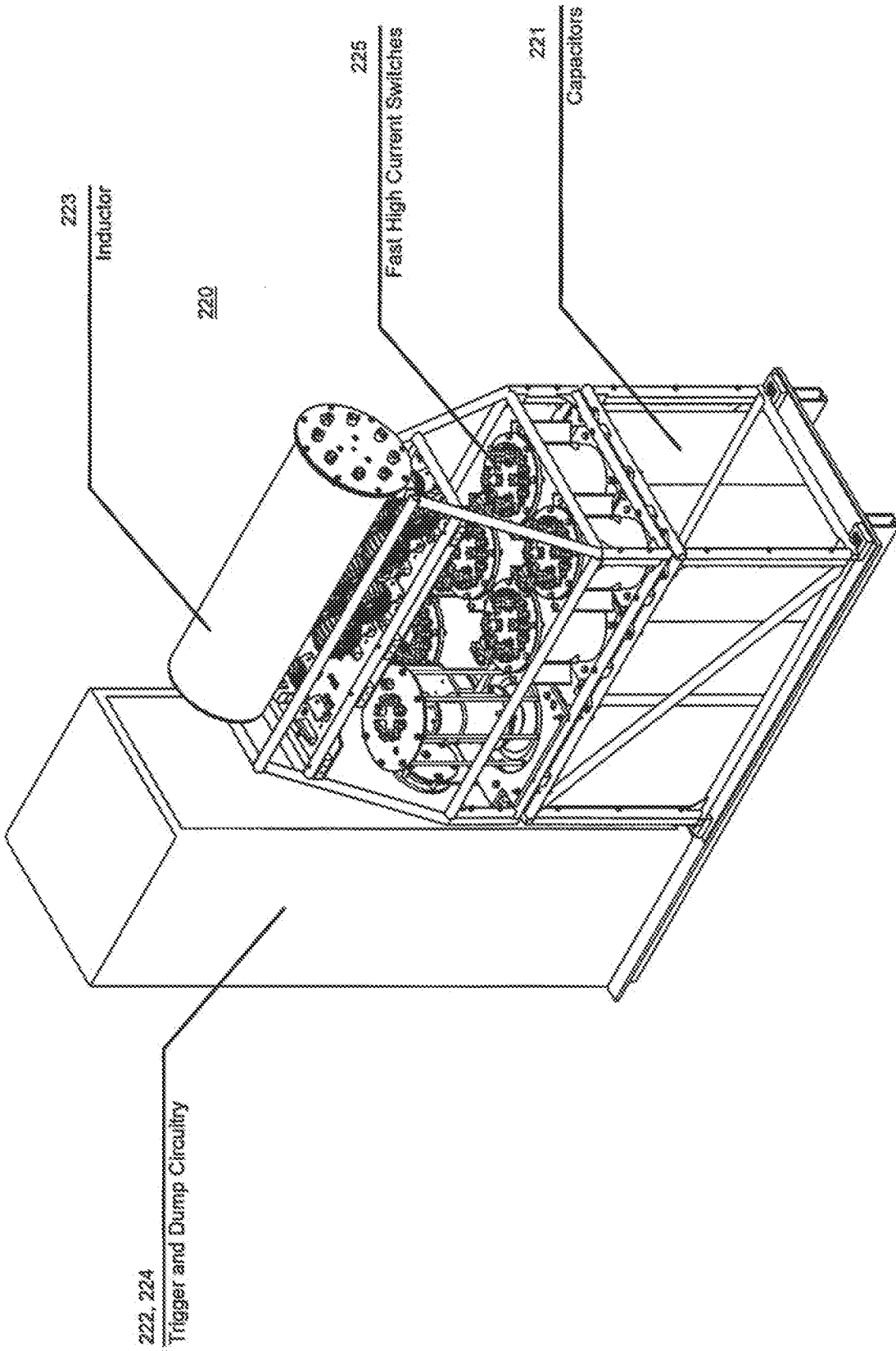

FIGURE 5

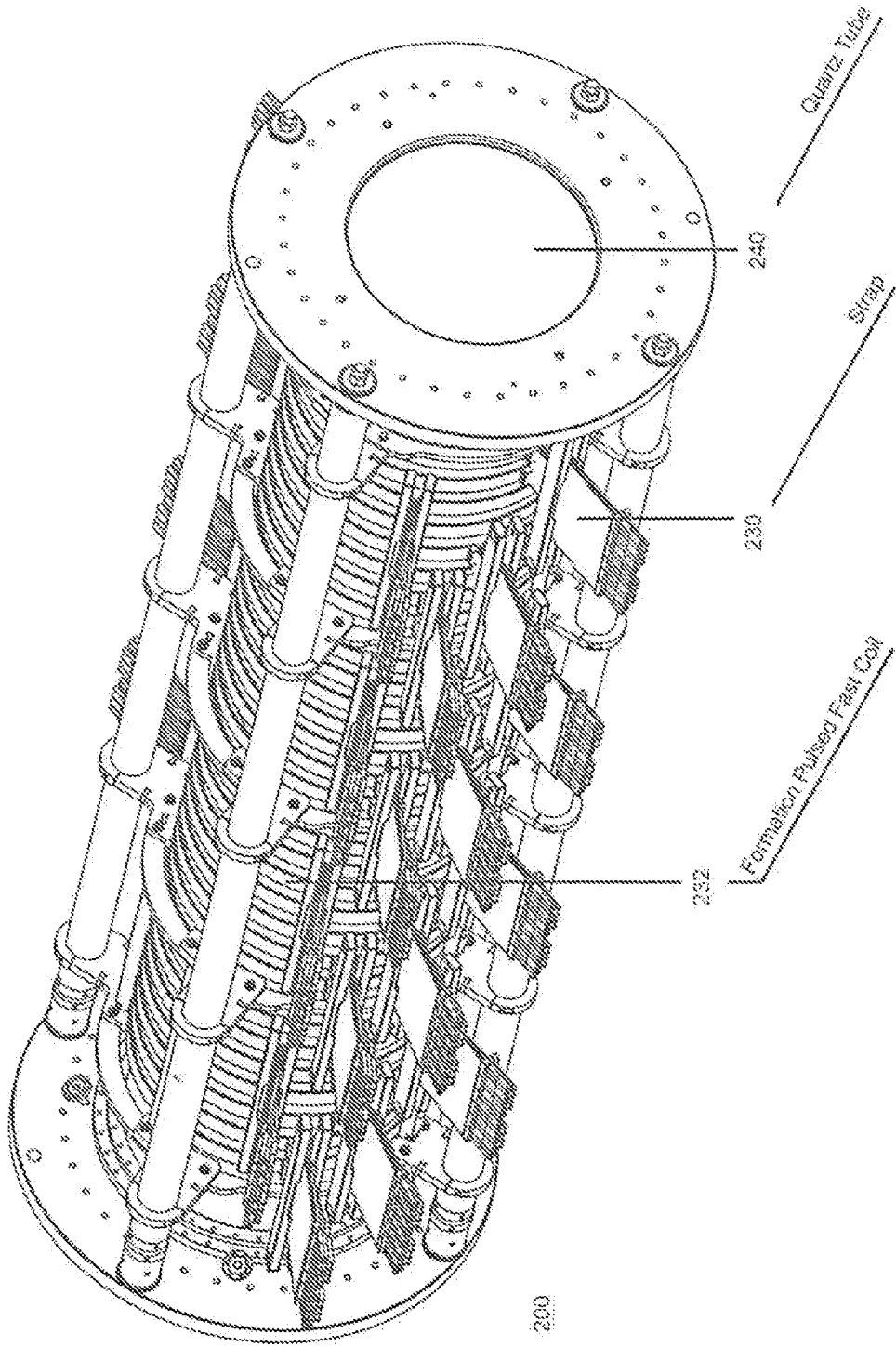

FIGURE 6

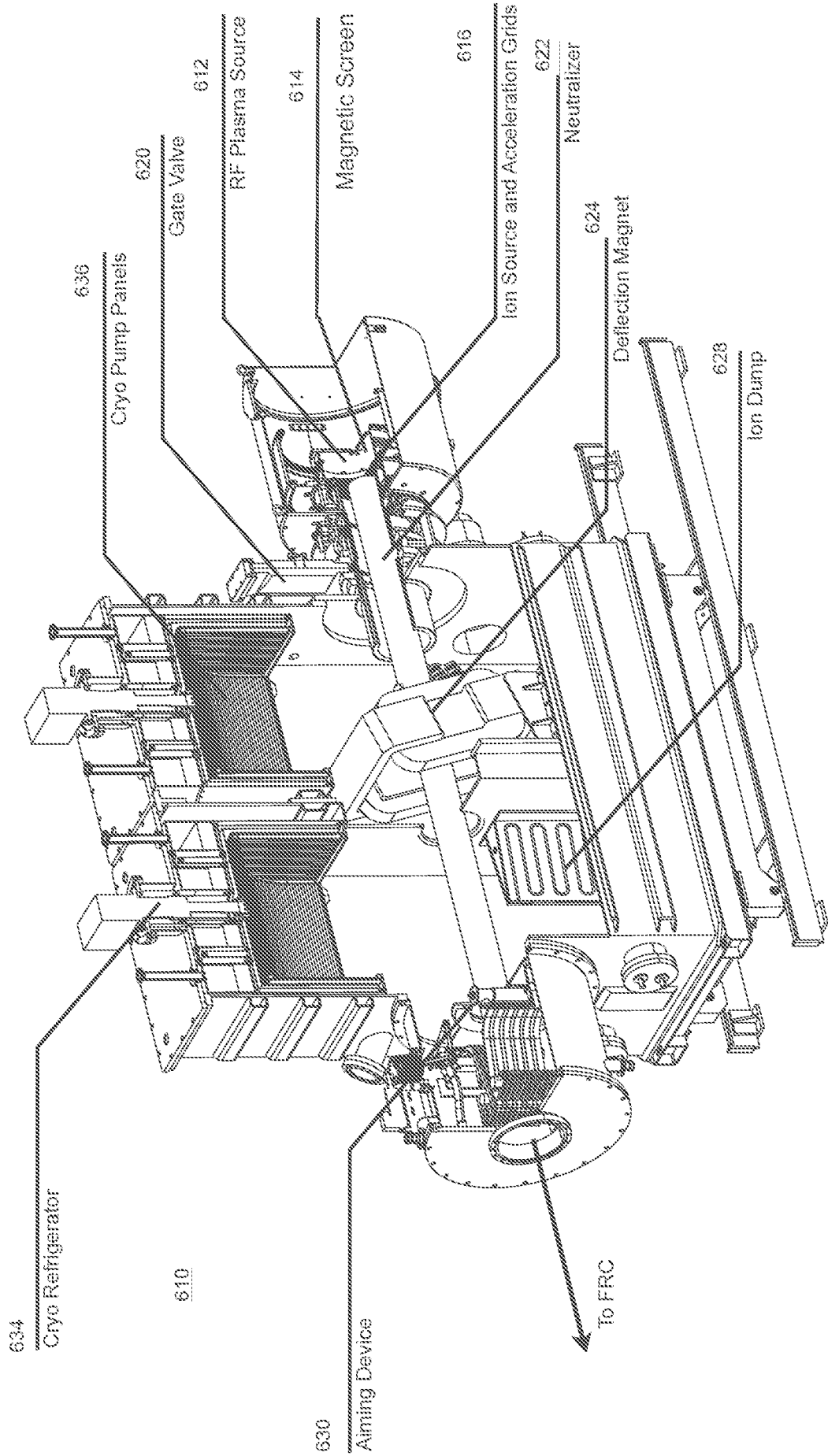

FIGURE 7

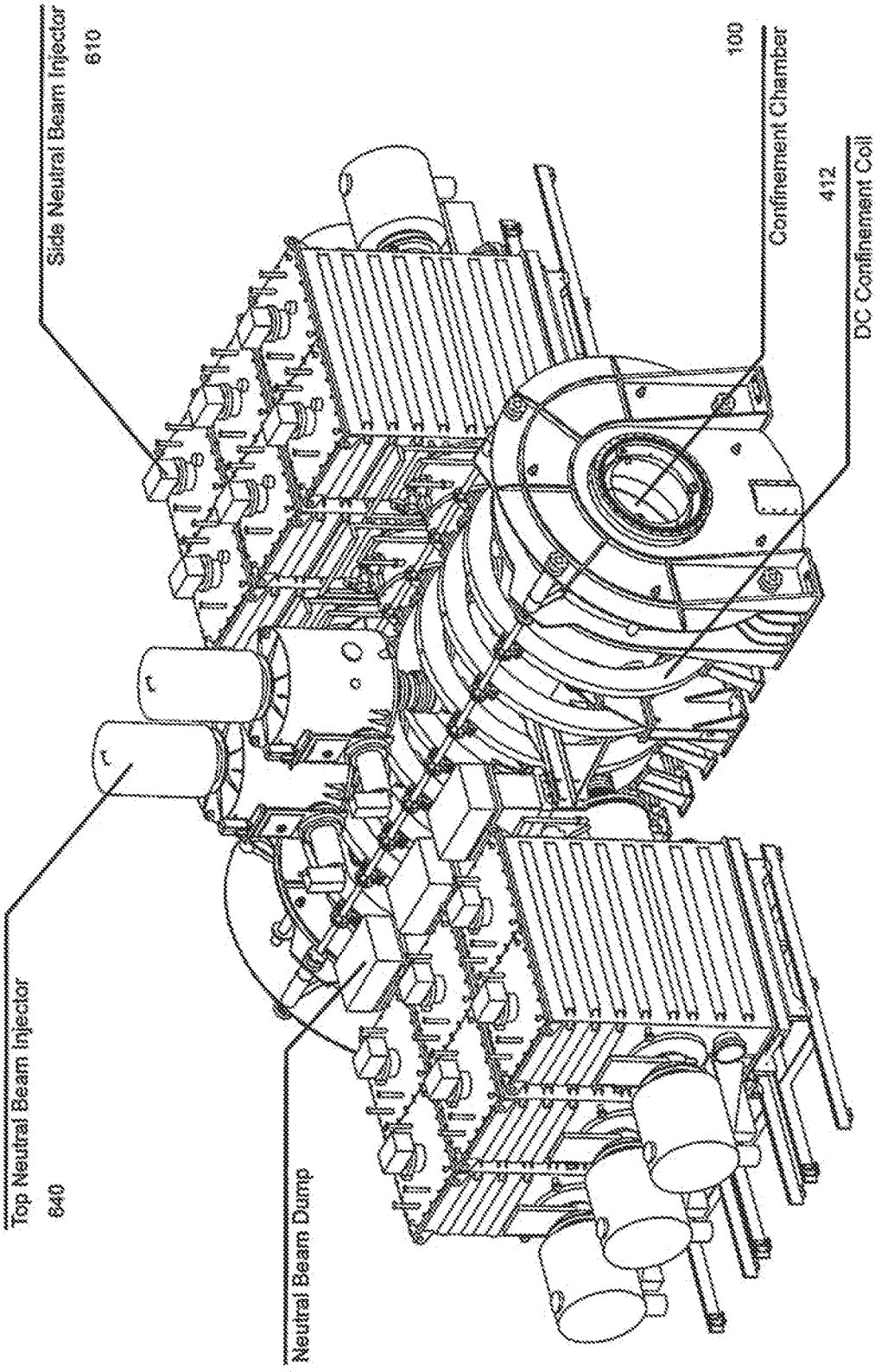

FIGURE 8

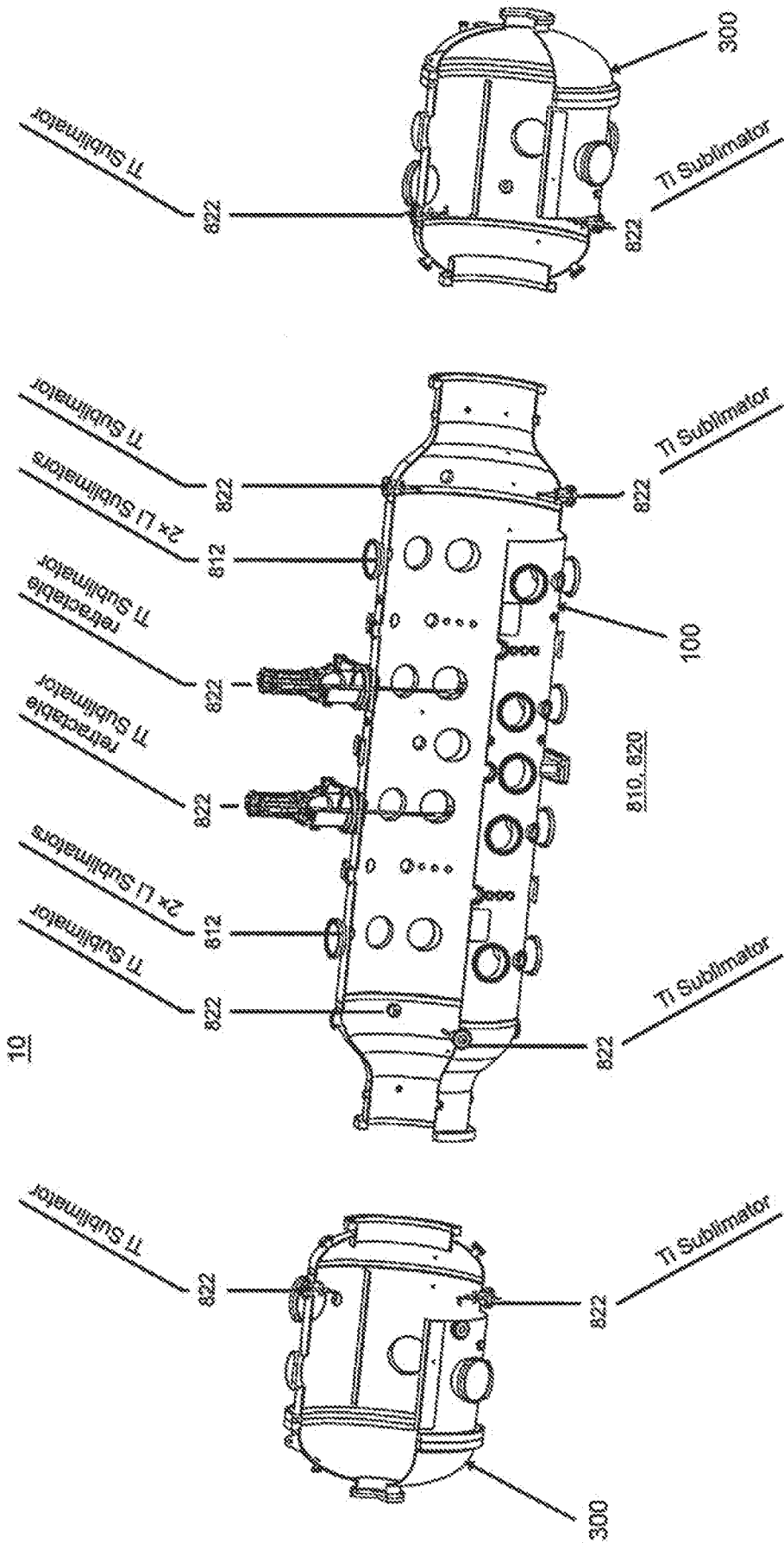

FIGURE 9

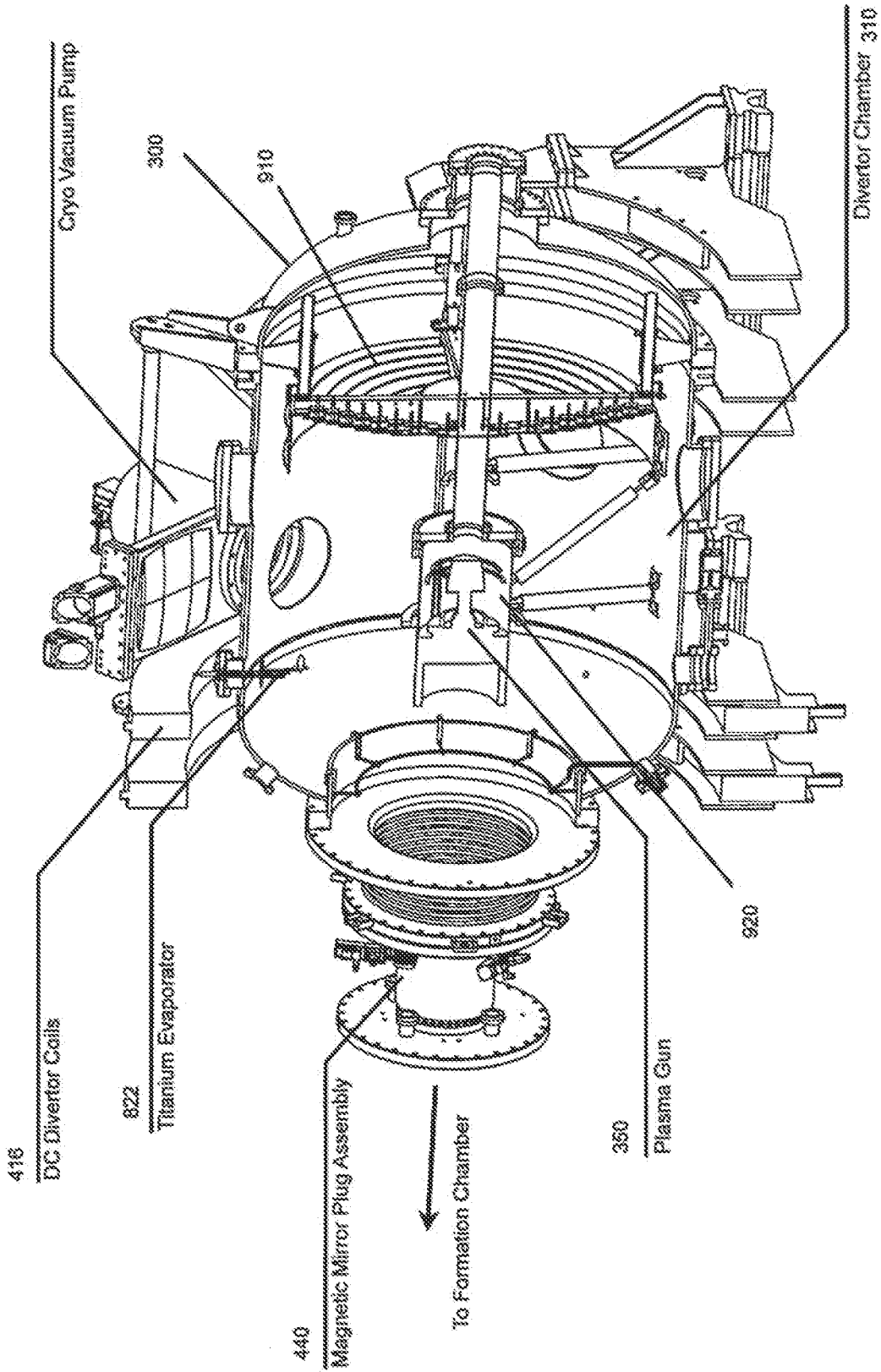

FIGURE 10

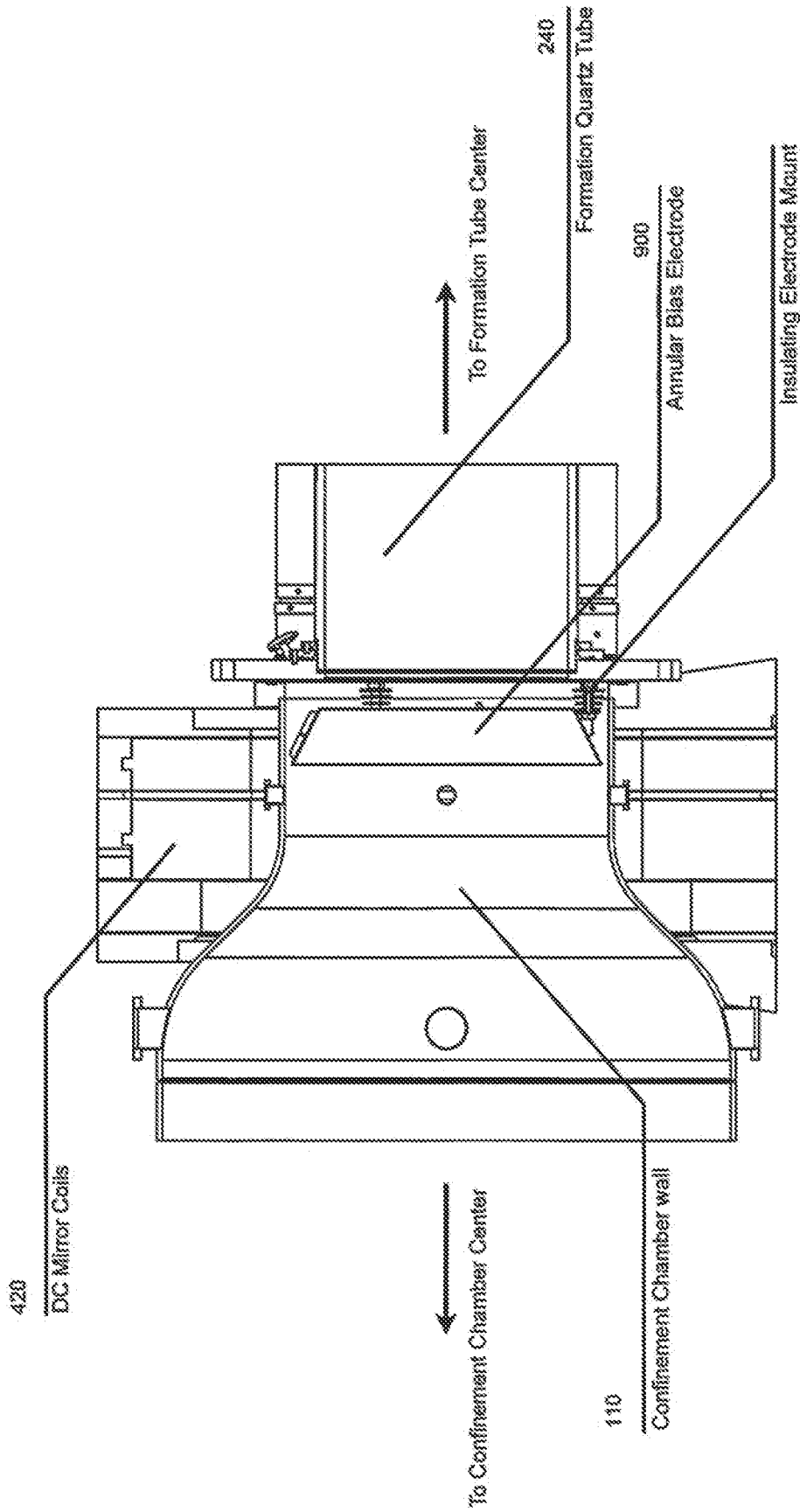

FIGURE 11

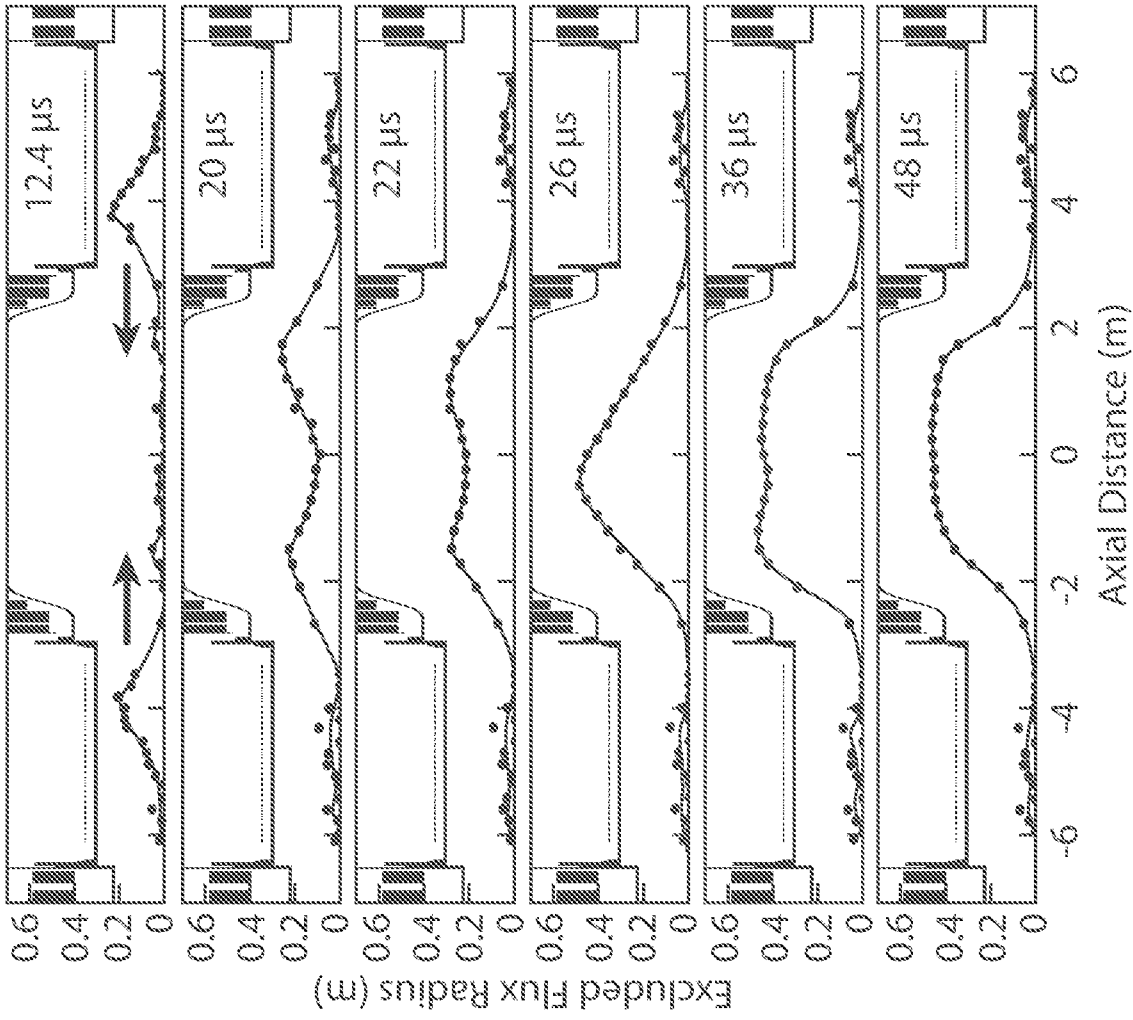

FIGURE 12

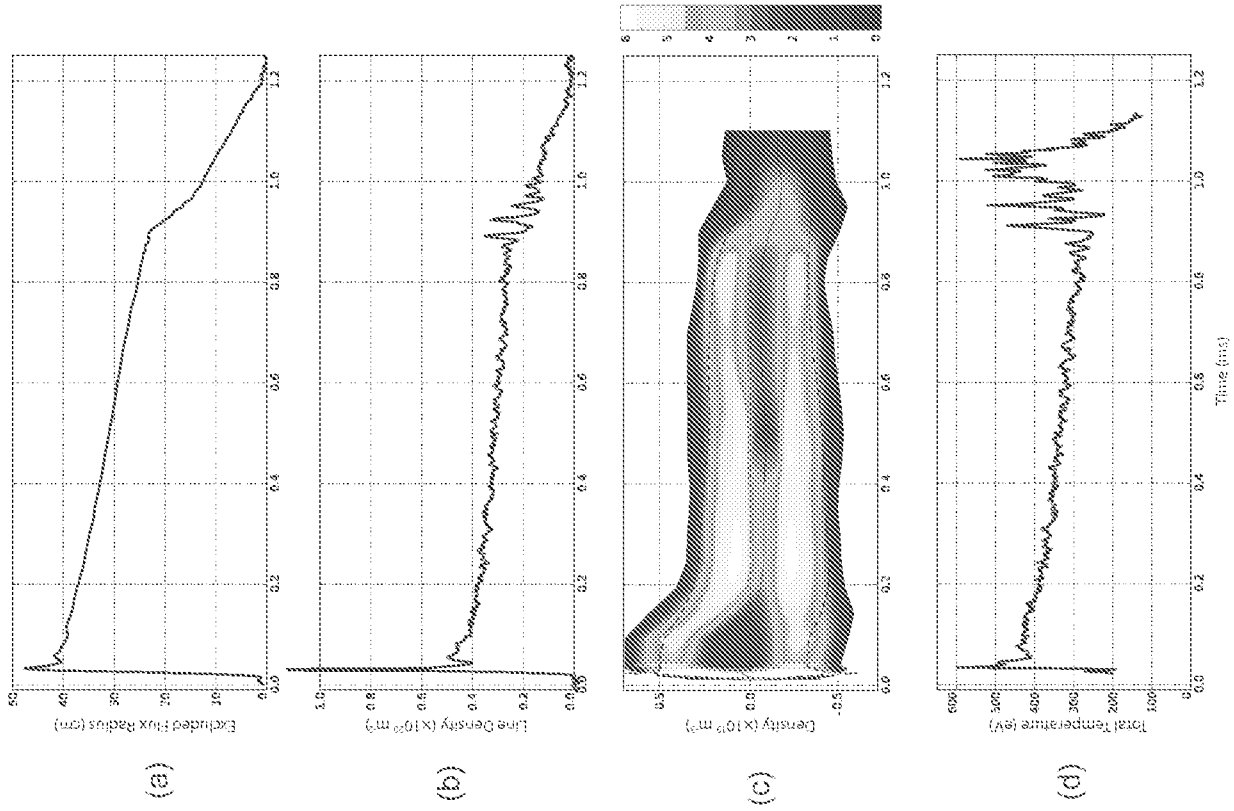

FIGURE 13

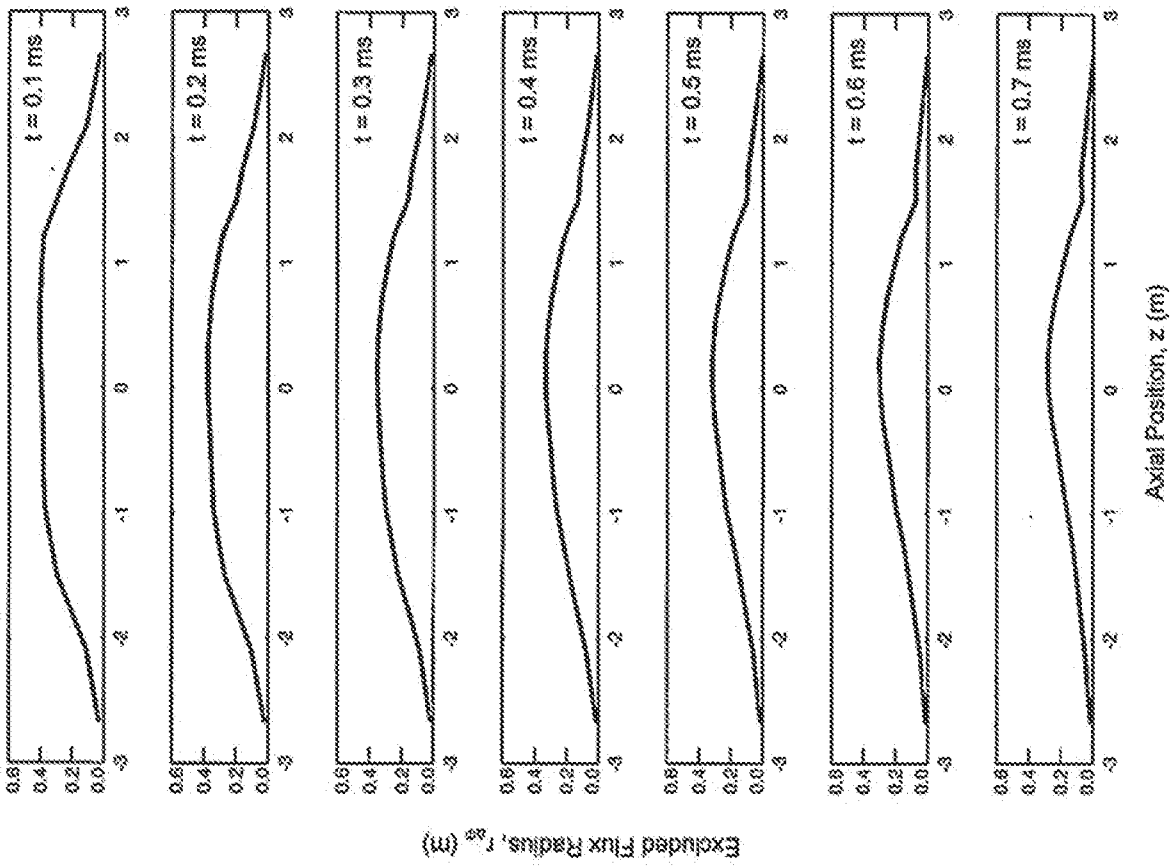

FIGURE 14

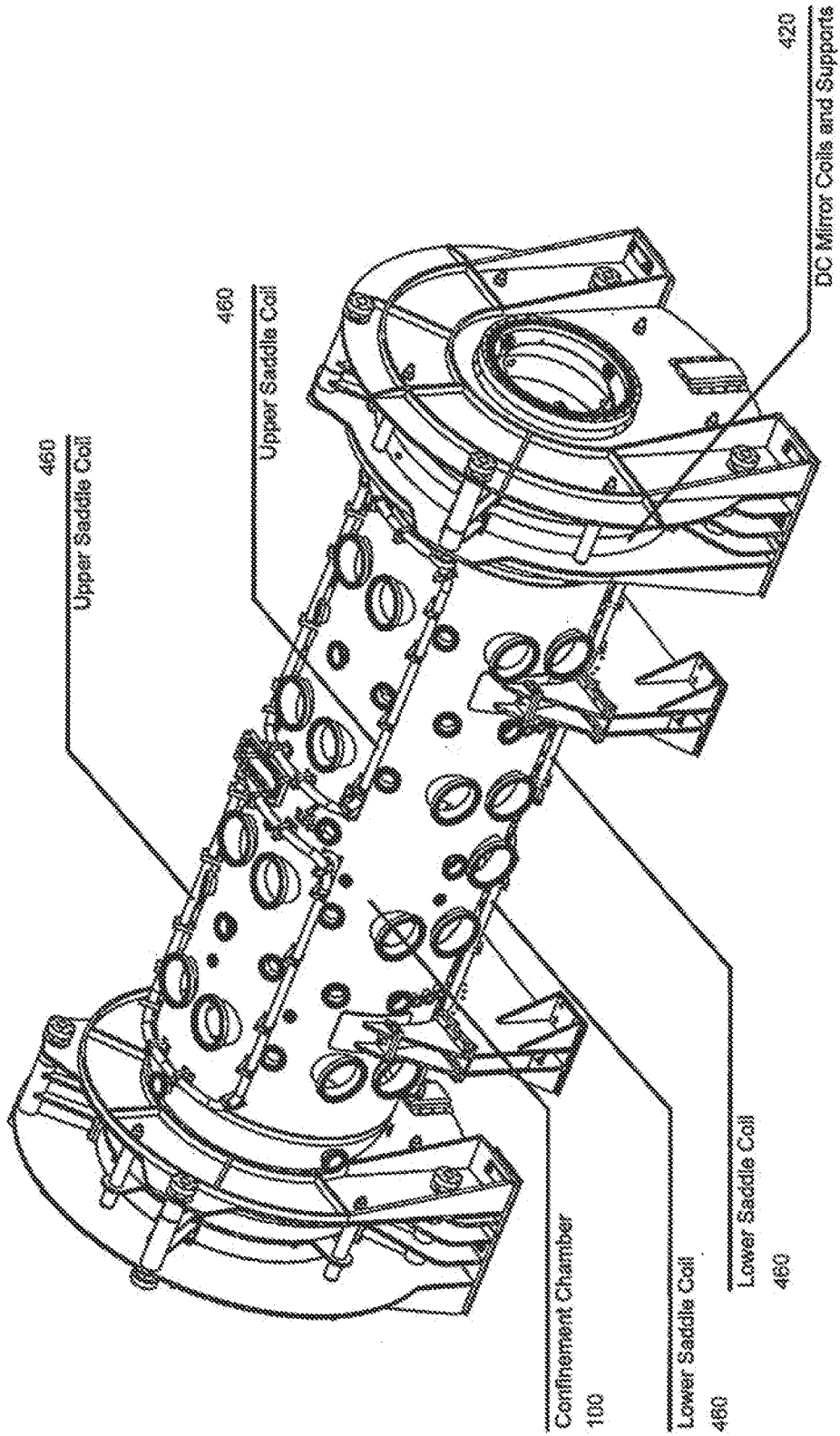

FIGURE 15

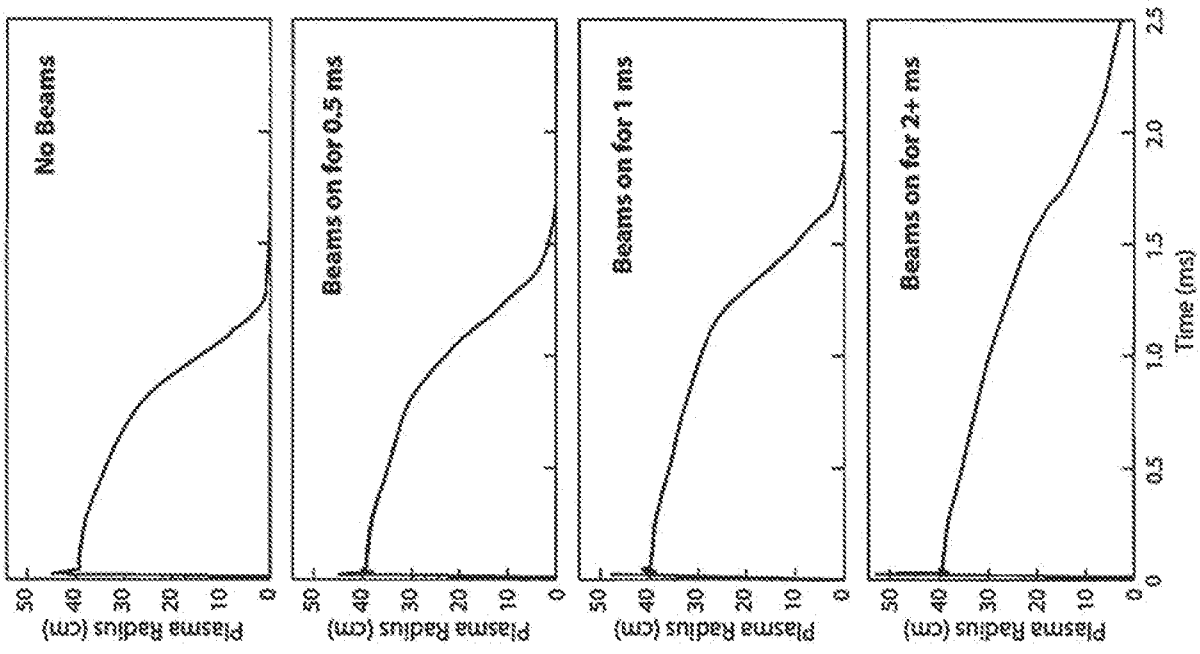

FIGURE 16

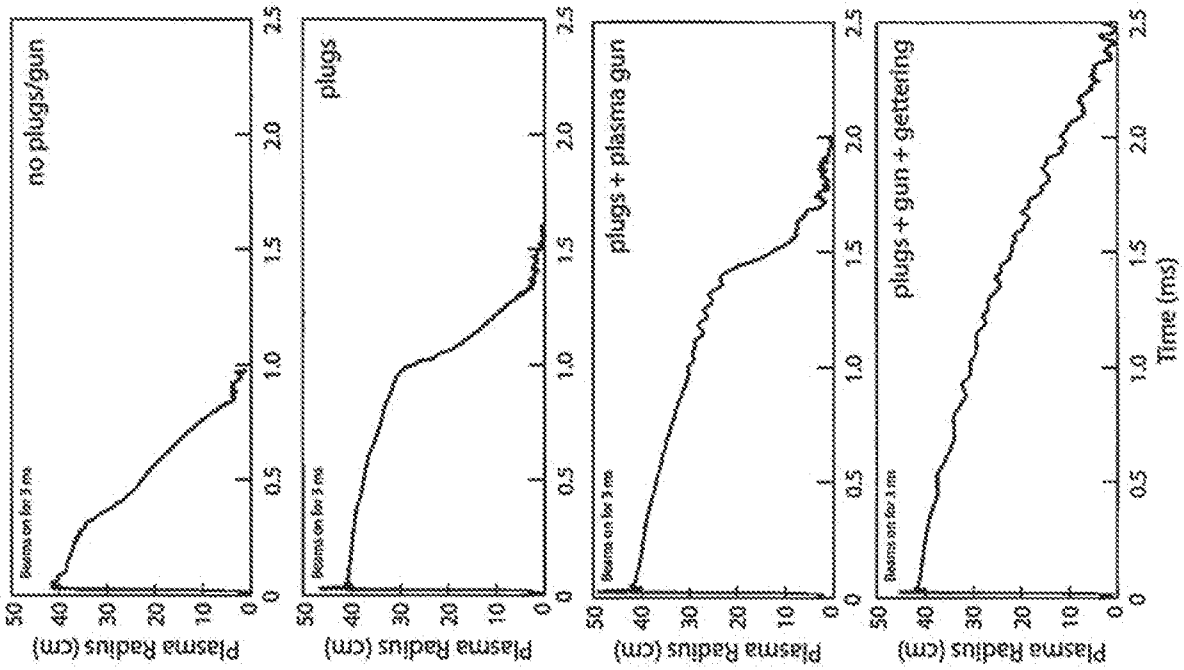

FIGURE 17

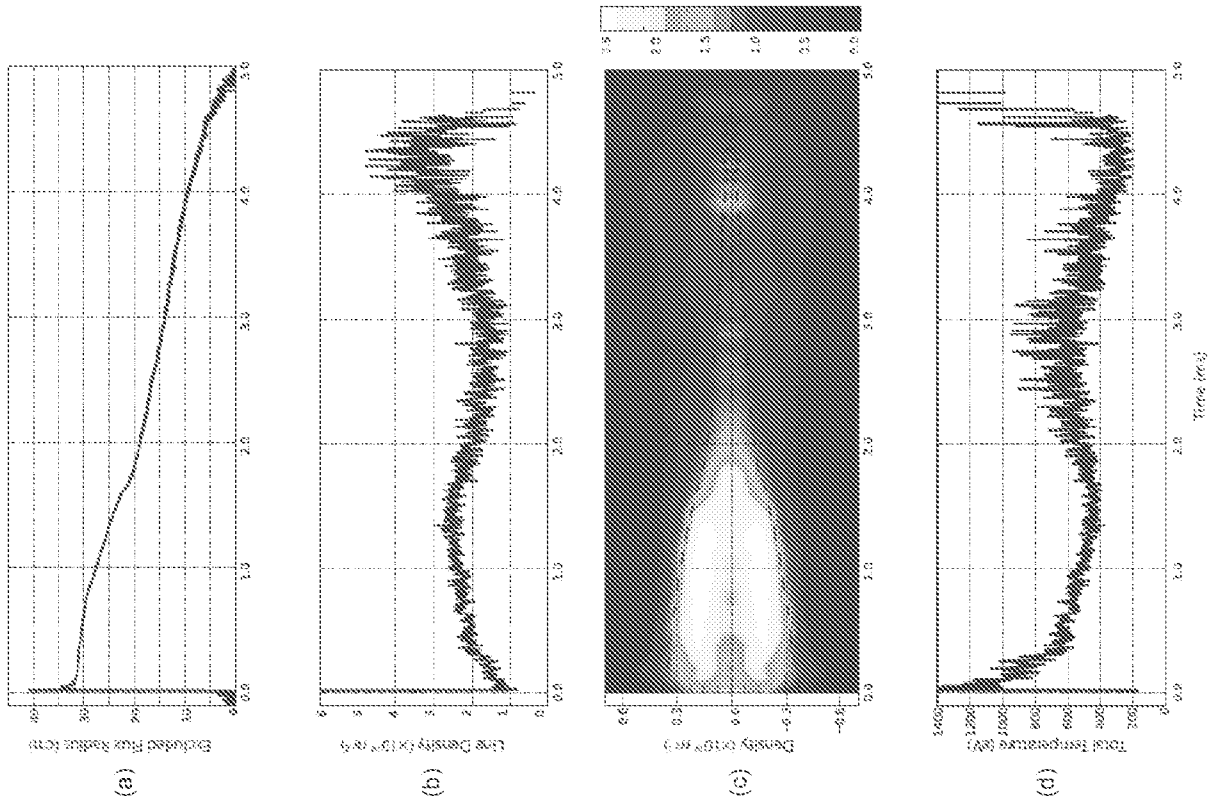

FIGURE 18

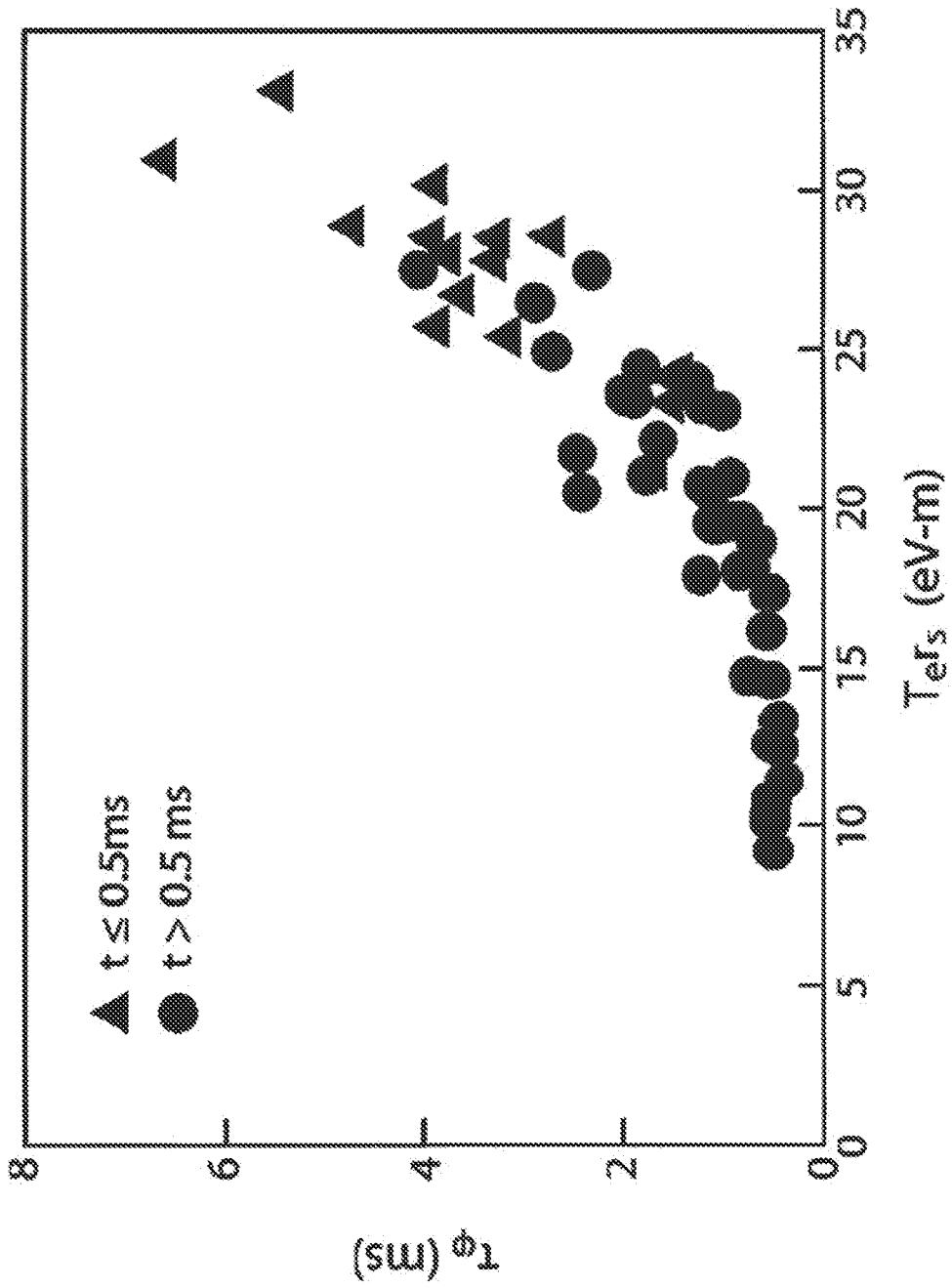

FIGURE 19

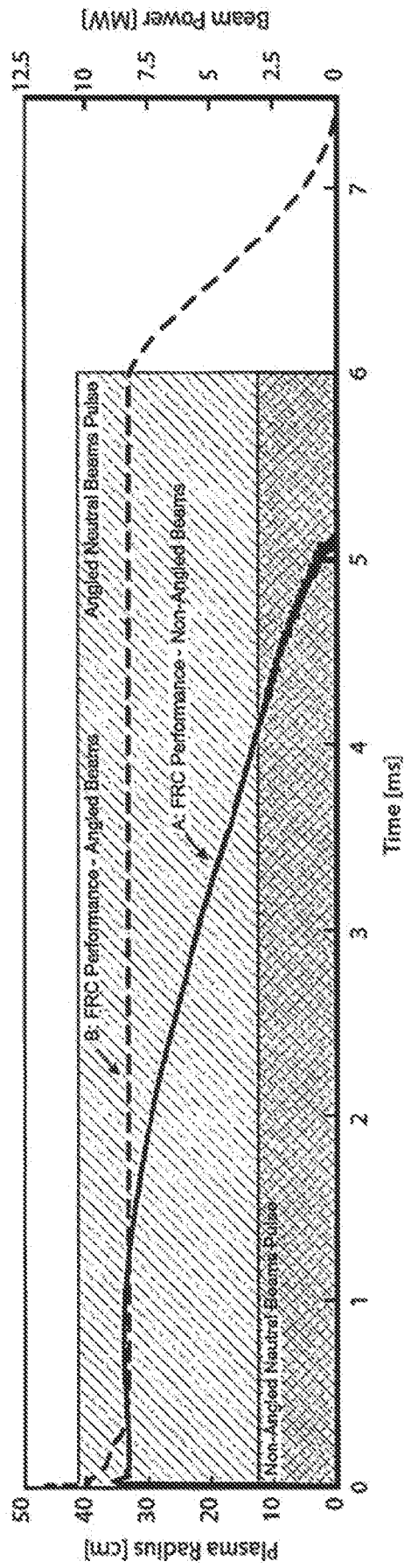

FIGURE 20

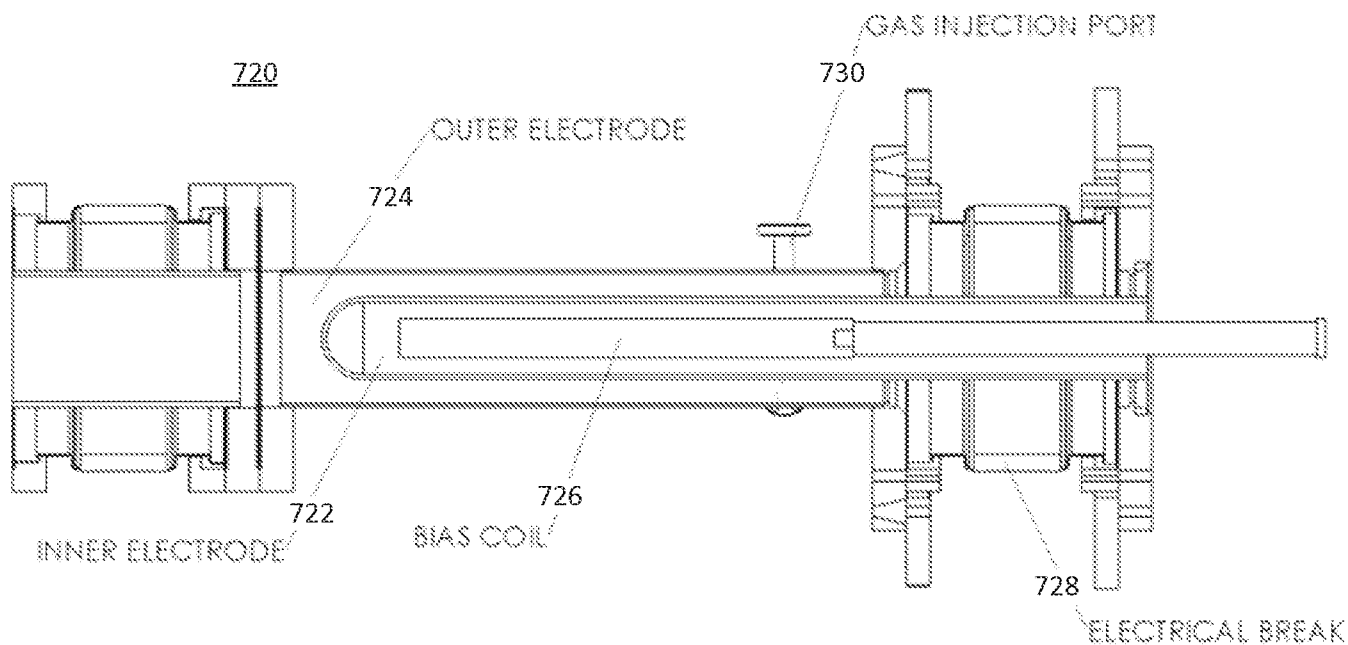

FIGURE 21A

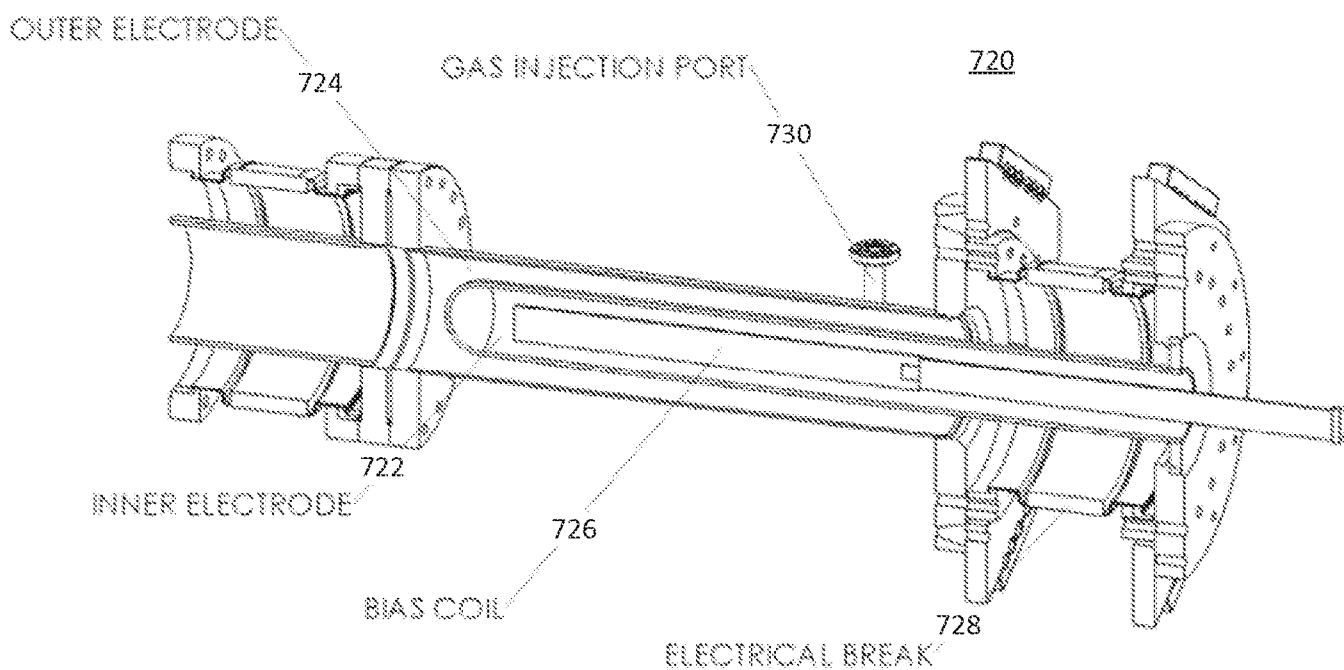

FIGURE 21B

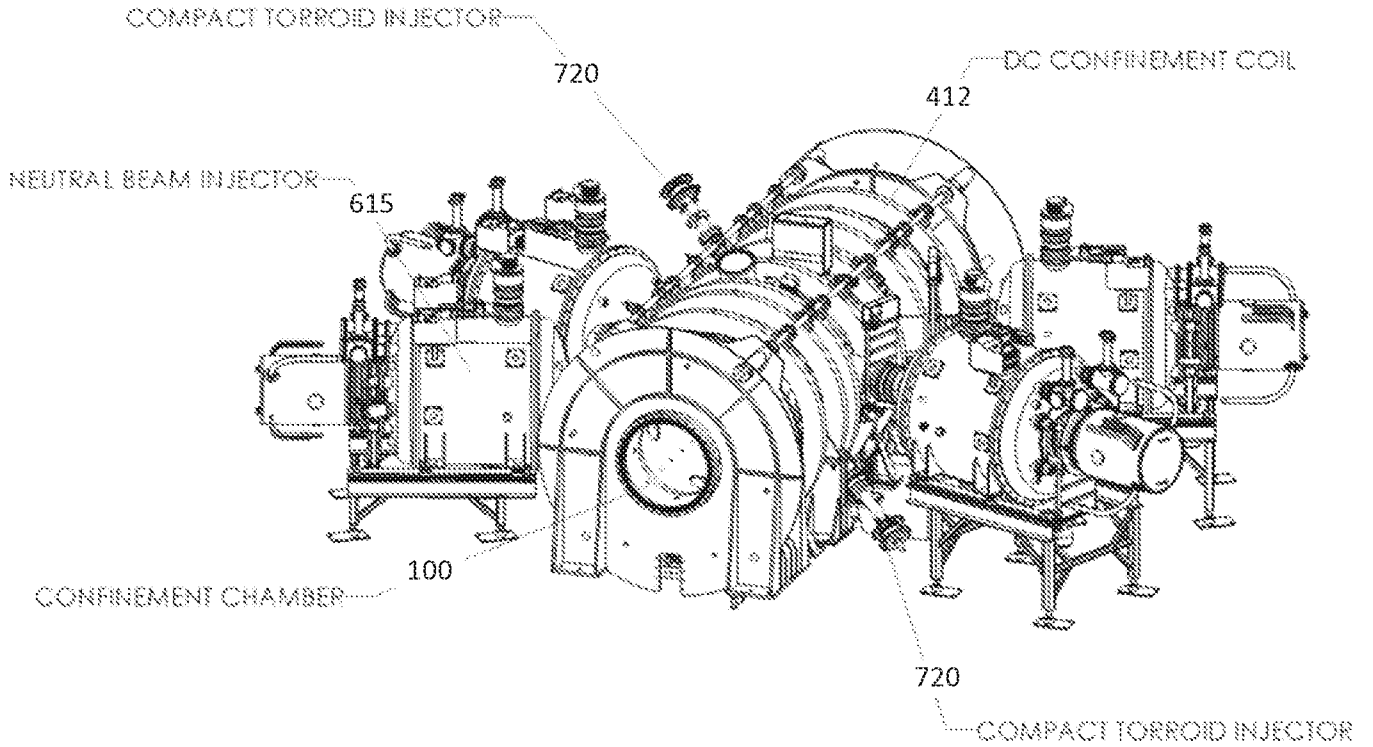

FIGURE 22A

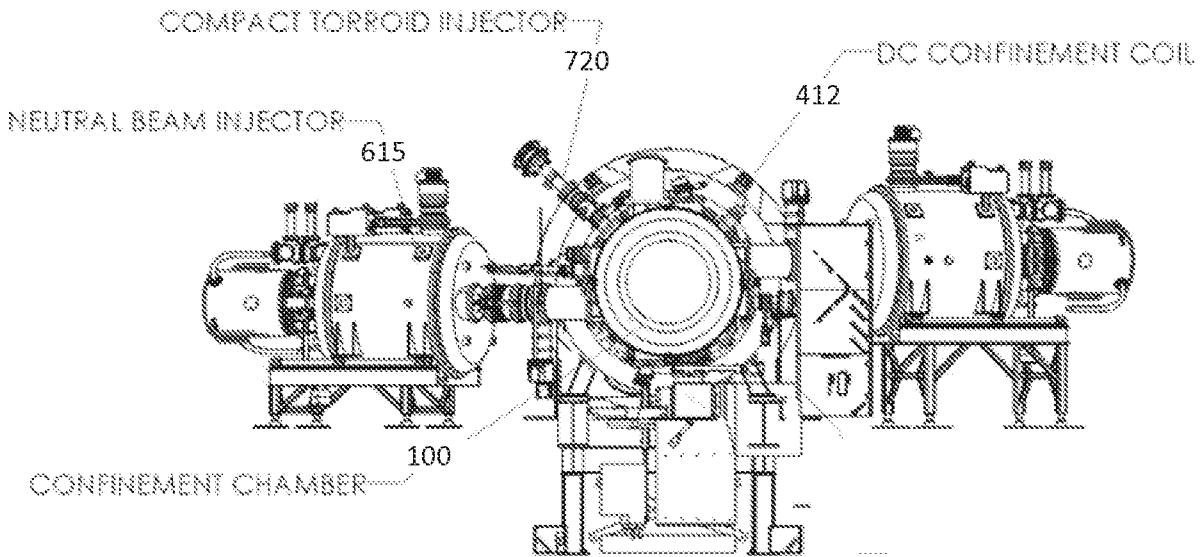

FIGURE 22B

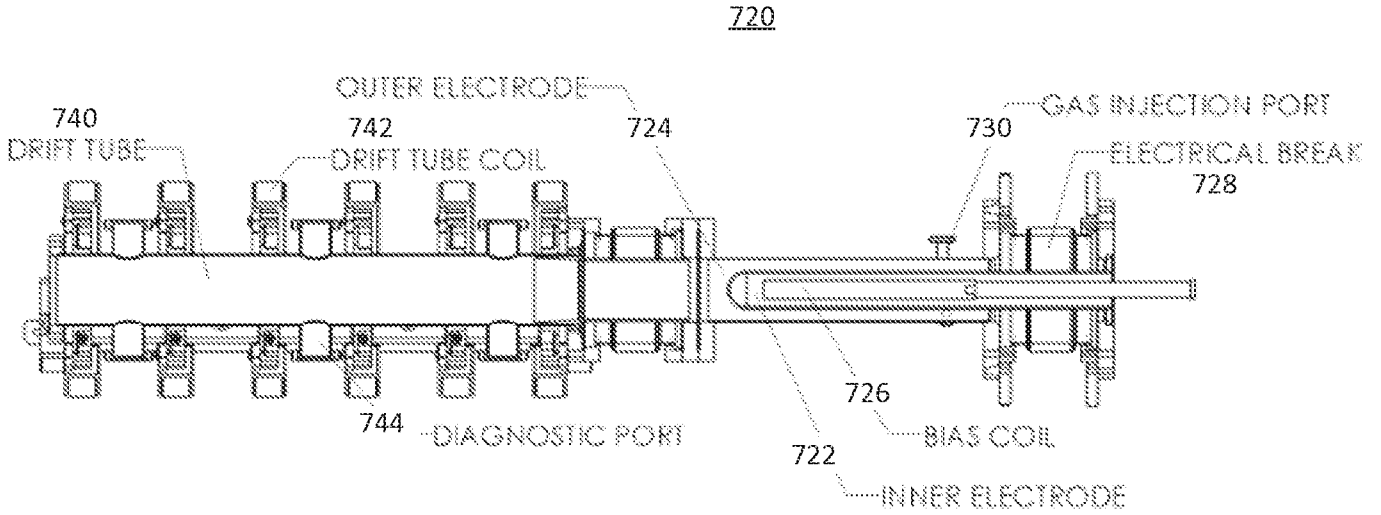

FIGURE 23A

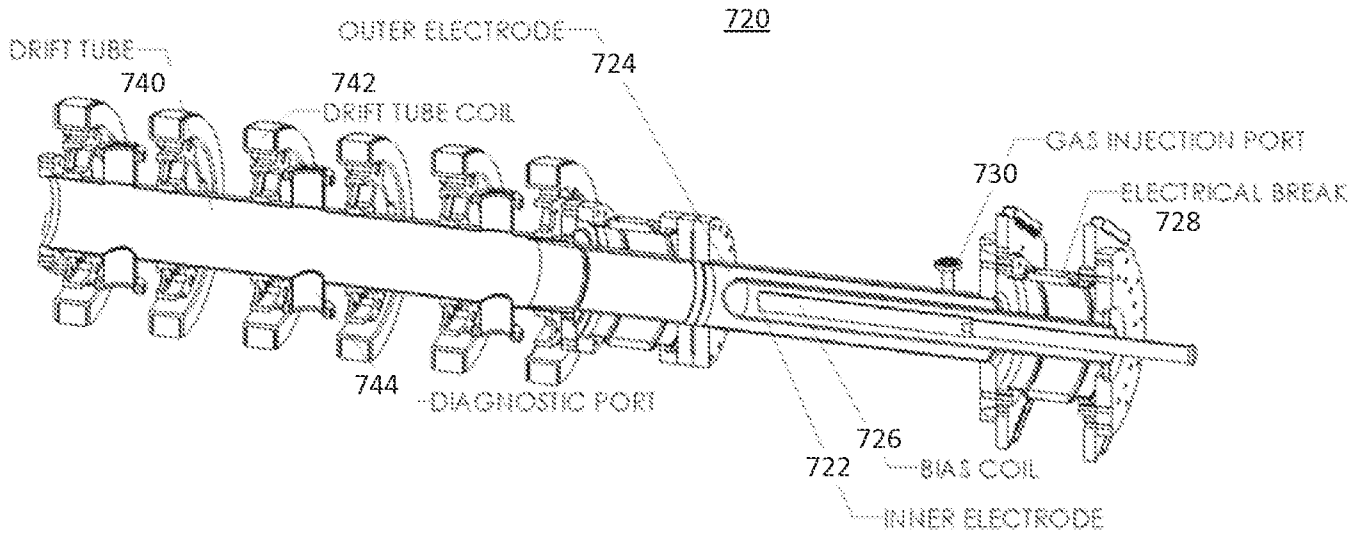

FIGURE 23B

