

(19) World Intellectual Property Organization  
International Bureau



(43) International Publication Date  
2 August 2001 (02.08.2001)

PCT

(10) International Publication Number  
**WO 01/56270 A2**

(51) International Patent Classification<sup>7</sup>: **H04N 5/00**

(21) International Application Number: PCT/US01/01706

(22) International Filing Date: 18 January 2001 (18.01.2001)

(25) Filing Language: English

(26) Publication Language: English

(30) Priority Data:  
09/491,787 26 January 2000 (26.01.2000) US

(71) Applicant: **INTEL CORPORATION** [US/US]; 2200 Mission College Blvd., Santa Clara, CA 95052 (US).

(72) Inventors: **WILSON, Andrew, T.**; 5737 SW Downsview Court, Portland, OR 97221 (US). **KINDER, David, B.**; 480 NW 87th Terrace, Portland, OR 97229 (US).

(74) Agent: **TROP, Timothy, N.**; Trop, Pruner & Hu, P.C., 8554 Katy Freeway, Suite 100, Houston, TX 77024 (US).

(81) Designated States (*national*): AE, AG, AL, AM, AT, AU, AZ, BA, BB, BG, BR, BY, BZ, CA, CH, CN, CR, CU, CZ, DE, DK, DM, DZ, EE, ES, FI, GB, GD, GE, GH, GM, HR, HU, ID, IL, IN, IS, JP, KE, KG, KP, KR, KZ, LC, LK, LR, LS, LT, LU, LV, MA, MD, MG, MK, MN, MW, MX, MZ, NO, NZ, PL, PT, RO, RU, SD, SE, SG, SI, SK, SL, TJ, TM, TR, TT, TZ, UA, UG, UZ, VN, YU, ZA, ZW.

(84) Designated States (*regional*): ARIPO patent (GH, GM, KE, LS, MW, MZ, SD, SL, SZ, TZ, UG, ZW), Eurasian patent (AM, AZ, BY, KG, KZ, MD, RU, TJ, TM), European patent (AT, BE, CH, CY, DE, DK, ES, FI, FR, GB, GR, IE, IT, LU, MC, NL, PT, SE, TR), OAPI patent (BF, BJ, CF, CG, CI, CM, GA, GN, GW, ML, MR, NE, SN, TD, TG).

**Published:**  
— without international search report and to be republished upon receipt of that report

For two-letter codes and other abbreviations, refer to the "Guidance Notes on Codes and Abbreviations" appearing at the beginning of each regular issue of the PCT Gazette.

(54) Title: BROADCAST PAUSE AND RESUME FOR ENHANCED TELEVISION

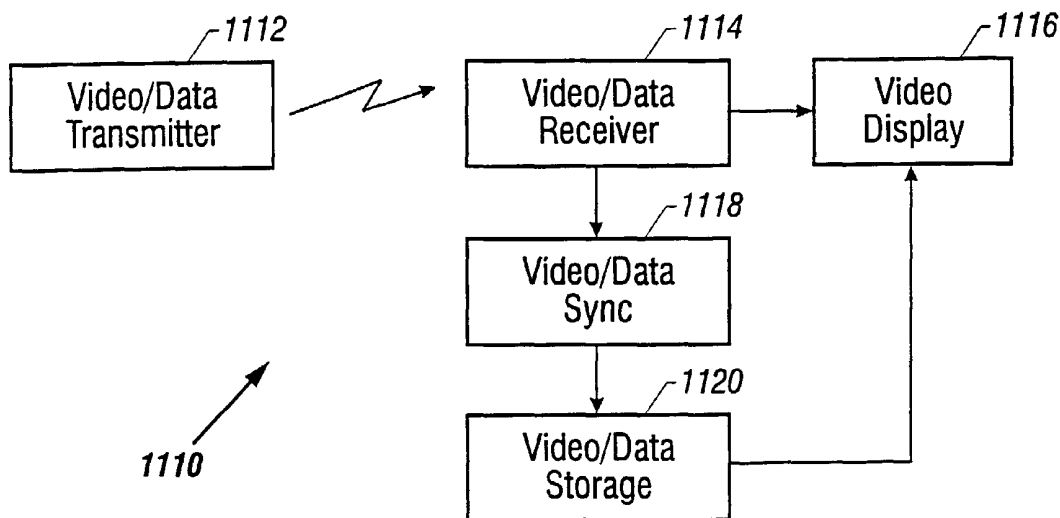

(57) Abstract: A broadcast pause and resume system (1114) may enable replay from a random access memory of video information received from a video distribution source (1112) such as cable, broadcast television or satellite distribution as examples. Key frames (1206) may be stored which enable the replay from the memory of both video and enhanced content. In some embodiments of the present invention, a reference to stored enhanced content may be stored (1434) instead of storing the entire contents of a browser cache (1436).



WO 01/56270 A2

## Broadcast Pause And Resume For Enhanced Television

### Background

This invention relates to the recording and playing back of a video stream. A video stream includes any combination of audio and/or video data streams.

5 Video streams have typically been recorded on analog media such as a video cassette. A video cassette recorder (VCR) is used to record the video stream on the video cassette. The video stream may arrive via a broadcast signal, via cable, via satellite signal, or from another video playback device. Once the video stream has been recorded, the VCR is used to rewind the recording medium and play what was recorded. However, due to the nature of the  
10 analog medium, once the VCR has started recording, it is not possible to play back the portion of the video stream that has already been recorded until the recording session is terminated.

Ancillary information, such as program sub-titles, emergency messages, closed caption messages, and program guide information, may be transmitted along with regular  
15 television content. More recently, other types of ancillary information that may be sent with television content include enhancement data such as Web pages, multimedia information, or other digital data files. Ancillary information may be sent in the vertical blanking interval (VBI) of an analog television broadcast signal or may be sent with digital television content over a digital transmission transport medium.

20 Various standards exist that provide for transmission of ancillary information along with television content. One standard is the Advanced Television Enhancement Forum (ATVEF) Specification, Draft Version 1.1r26, dated February 2, 1999. The ATVEF specification provides for transmission of enhancement data along with television content in both analog and digital systems, such as cable systems, satellite systems, terrestrial systems,  
25 and so forth.

There is a need for an improved way of recording portions of a video transmission containing enhanced content.

### Brief Description of the Drawings

30 Figure 1 is a block diagram of a video record and playback system in accordance with one embodiment of the invention;

- 2 -

Figure 2 is a flow chart of one embodiment of the method of providing a time-shifted video stream in accordance with the invention;

Figure 3 shows one embodiment of an apparatus for storing the video stream on a hard disk in accordance with the invention;

5 Figure 4 is a flow chart showing one embodiment of a system for recording and playing back a video stream in accordance with the invention;

Figure 5 is a block diagram of a computer system useful in implementing one embodiment of the present invention;

10 Figure 6 is an exemplary TV display for implementing an embodiment of the present invention;

Figure 7 is a block diagram showing how data is transferred to and from a memory device in accordance with one embodiment of the present invention;

Figure 8 is a flow chart showing the flow of input video information into a storage device in accordance with one embodiment of the present invention;

15 Figure 9 is a flow chart showing the flow of data from the storage device in accordance with one embodiment of the present invention;

Figure 10 a schematic depiction of one embodiment of the present invention;

Figure 11 is a schematic depiction of an embodiment of the present invention with synchronized video and data in accordance with one embodiment of the present invention;

20 Figure 12 is a schematic depiction of one embodiment of the present invention implementing a software key frame;

Figure 13 is a flow chart for a software for implementing one embodiment of the present invention;

25 Figure 14 is a schematic depiction of a data format that may be used in the embodiment shown in Figure 11; and

Figure 15 is a schematic depiction of another data format that may be used with the embodiment of Figure 11.

### Detailed Description

30 A video record and playback system 100, in accordance with one embodiment of the invention shown in Figure 1, receives a video stream at the video input port 102. The video stream may be provided by a camera, a television signal, broadcast, cable, or satellite signals,

or another video playback device. In one embodiment, an analog-to-digital conversion may be performed on an analog video stream to form a digital video bit stream. In a different embodiment, the video is already in digital form. The video record and playback system 100 may be part of a system, such as a computer system or set top box, such that the video input port 102 may be part of a video capture card in the computer system or set top box.

The digital video stream from the video input port 102 is optionally compressed at compression unit 104. In one embodiment, the video is already compressed and no further compression is needed. The video stream is then stored in the storage unit 108. A buffer unit 106 may be used as temporary storage for providing larger sequential blocks of video data to the storage unit 108. In one embodiment, the buffer unit 106 comprises a random access memory that allows relatively quick access to any portion of the stored video stream.

The video stream is played back by reading the video stream from the storage unit 108. If the video stream was compressed in compression unit 104, then a decompression unit 110 decompresses the retrieved video stream. The video stream is provided from a video output port 120, to a monitor or other display device such as a TV to provide sound and/or video to a user.

A removable storage unit 122 may also be included in video record and playback system 100. Examples of removable storage units include a writeable compact disk read only memory (CD-ROM), writeable digital video disk (DVD), a flash memory, or another hard disk. The availability of a removable storage unit 122 allows a user to transfer a recording of a video stream stored in storage unit 108 to the removable storage unit 122 and then to transfer the unit 122 to another system at a different location.

In one embodiment, a processor 130 controls the operations of the video record and playback system 100. The compression unit 104 and decompression unit 110 may be implemented in hardware, or the compression and decompression functions of units 104 and 110 may be performed by the processor 130. Processor 130 receives instructions from firmware/memory 140, using technology that is well known.

Figure 2 shows a flow chart of an embodiment of a method of providing a time-shifted video stream in accordance with one embodiment of the present invention. The flow chart begins at block 200, and continues at block 202 where the video stream is received. The recording of the video stream begins at block 204. At block 206, playback of the recorded video stream is performed by retrieving a portion of the video stream from the

random access storage unit while the recording of the incoming video stream continues. The retrieved portion of the video stream may be time-shifted from the incoming video stream by a time delay. At block 208, the portion of the video stream retrieved from the random access storage unit is retrieved for display by a television or other display device.

5 In this way, the record and playback functions are decoupled from one another. The user may now begin watching a recorded TV show from the beginning, e.g., prior to the show being completely recorded.

10 Figure 3 shows one embodiment of an apparatus for storing the video stream in the storage unit 108 in accordance with one embodiment of the invention. Again, the invention is not restricted in scope to the illustrated embodiments. In this embodiment, the video stream is stored as separate files 001 and 009 on a hard disk, for example. The processor 130 keeps track of the file and offset into the file of the data being played back, as well as the file and offset into the file of the data being recorded. If the random access storage unit is fast enough, more than one video stream may be recorded and played back at the same time.

15 Referring now to the embodiment shown in Figure 4, a flow chart 400 for digitally recording a video stream in accordance with one embodiment of the invention begins by receiving the video stream as indicated in block 402. If the stream is an analog stream (diamond 403), it may be digitized in an analog-to-digital conversion process as indicated at block 404. Next the digital stream may be encoded and compressed, for example using a compression scheme, as indicated in block 406. The stream is alternately read, as indicated at 20 block 410, and stored, as indicated in block 408, in a conventional storage device such as a hard disk drive, a digital video disk or a flash memory. Data that is read from the storage device may be decoded and decompressed using conventional technology, for example, as indicated in block 412, for display as indicated in block 414.

25 A system 500 in accordance with one embodiment of the present invention, shown in Figure 5, includes a processor 502. In one embodiment, the processor may be coupled to an accelerated graphics port (AGP) chipset 504 for implementing an accelerated graphics port embodiment. The chipset 504 communicates with the AGP port 505 and the graphics accelerator 506. The television 510 may be coupled to the video output of the graphics 30 accelerator 506. The chipset 504 accommodates the system memory 508. The chipset 504 is also coupled to a bus 512 which may be, for example, a peripheral component interconnect (PCI) bus (PCI Local Bus Specification, Version 2.2 dated June 1, 1998). The bus 512

- 5 -

couples to a TV tuner/capture card 514 which is coupled to an antenna 515 or other video input port, such as a cable input port, a satellite receiver/antenna or the like. The TV tuner and capture card 514 selects a desired television channel and also performs the video capture function (block 402, Figure 4). One example of video capture card is the ISVR-III video capture card available from Intel Corporation.

The bus 512 is also coupled to a bridge 516 which couples a hard disk drive 518. The software 200, 400, 900, 1206 and 1300 may be stored on the hard disk 518. The bridge 516 is also coupled to another bus 532. The bus 532 may be coupled to a serial input/output (SIO) device 534. The device 534 is in turn coupled to conventional components such as a mouse 536, a keyboard 538, and an infrared interface 540. Also coupled to the bus 532 is a basic input/output system (BIOS) 542.

An example of a display 600, shown in Figure 6, for the television 510 may display a conventional television picture or program 601 and, in addition, may have superimposed over the screen, in a discrete fashion, a mouse selectable series of icons, such as the icons 602 through 614. When the mouse cursor 616 selects the appropriate one of the icons, a corresponding feature may be implemented. Among the features that may be implemented in this fashion include a pause or stop function 602, a start record function 604, a fast forward function 606, a rewind function 608, and a 10 second replay function 610 which winds back 10 seconds (or some other amount) and replays, and a catchup function 612 that begins playing back recorded content at a faster than normal rate until the display catches up with a live broadcast and an electronic program guide 614. The above described functions 602, 604, 606, 608, 610, and 612 may also be individual buttons on a remote control unit.

Techniques for storing the video stream onto the storage device 710 and for reading the information out of the storage device are summarized in Table 1 below and illustrated in Figures 7, 8, and 9. In Figure 7, a schematic depiction of the storage system 700 includes a digital storage device such as a hard disk drive 710. The digitized video 702 is initially stored in a buffer which is designated as being currently on the top of the memory stack. The transfer of information between the buffers and the storage device 710 may be done in discrete time periods referred to herein as time steps.

	Time Steps								
Buffers	1	2	3	4	5	6	7	8	9
Input	704	708	706	704	708	706	704	708	706
Storage Read	X	X	X	712 714	X	714 716	X	712 716	X
Write	X	X	704 708	X	704 706	X	706 708	X	704 708
Output	X	X	X	X	714	712	716	714	712

**Table 1 (X = no action)**

In a first time step, shown in Figure 8, the digitized video 702 (Figure 7) is stored in memory buffer 704 because that buffer is currently at the top of the memory stack, as indicated in block 802 in Figure 8.

As the buffer 704 fills up, the buffer 708 moves to the top of the stack (as indicated by the dashed arrow) and incoming video is stored in buffer 708. As indicated in block 804 in Figure 8 in time step 2, the buffer 708 replaces the buffer 704 as the designated top of the stack buffer. The next input video is then stored in the new buffer (708) as indicated in block 806.

In time step 3 the buffer 708 has filled up and the contents of buffers 704 and 708 are written to the storage device 710 in a single write operation. During the same time step, buffer 706 moves to the top of the stack and becomes the storage buffer for incoming video. This is illustrated in blocks 808, 810 and 812 in Figure 8.

In time step 4, the buffer 704 moves back to the top of the stack to store incoming video since its previous content has already been saved in the storage device 710. This is indicated in block 814 of Figure 8. Additionally, in time step 4, the content of buffer 708 is written to the storage device 710 as illustrated in block 815. The storing of incoming information, as illustrated in Figure 8 then cycles back to the top of the flow in Figure 8 and continues in the same fashion thereafter.

The content from the storage device 710 is then read into buffers 712 and 714 in time step 4 and block 802.

In time step 5, the buffer 708 moves to the top of the stack to store incoming video, and buffer 714 moves to the top of the output stack and transfers data to the video output 718. The contents of the buffers 704 and 706 are then written to the storage device 710.

The time steps 1 to 5 illustrate a complete cycle from input to output. The remaining sequence of steps repeat starting at step 1 through 4 for the input of data and time steps 4 through 9 repeat for the output of data.

5 Referring now solely to Figures 7 and 9, in time step 6, information stored in the storage device is read to the sixth and fourth buffers (i.e., buffers 714 and 716) as indicated in block 906. The contents of the fifth buffer (712) are sent to the output port 718.

In time step 7, the contents of the sixth buffer (which is buffer 716) are sent to the output port 718. No other output operations occur.

10 In time step 8, the contents from the storage device 710 are read into the fifth and sixth buffers (buffers 712 and 716) as indicated in block 912. Also the contents of the fourth buffer (buffer 714) are passed to the output port 718 as indicated in block 914.

Finally, during time step 9 the contents of the fifth buffer (buffer 712) are passed to the output port 318, completing the cycle.

15 Using these techniques, the storage device is provided with enough time, through the operation of the buffers, to write the incoming video while supplying enough data simultaneously to the output display. Since the memory is used to make sure no content is dropped at the input end and the display is never starved at the output end, continuous display can be provided without losing information. In addition reading and writing larger chunks of data at one time reduces the amount of storage device head movement, thereby allowing the  
20 storage device to keep up with the read and write requests.

The size of the individual buffers 704 to 708 and 712 to 716 ("B") in megabytes is dependent at least in part on a number of factors including the input/output data rate "D", for example in megabytes per second, the effective bandwidth of the storage device when reading or writing "S", for example in megabytes per second, and the average seek time for  
25 the storage device per transaction "t", in microseconds. The time that it takes to fill up one memory buffer (B divided by D) is advantageously greater than the time it takes to read or write two memory buffers (2B divided by S) plus the average seek time (t):

$$\left(\frac{B}{D}\right) \geq \left(\frac{2B}{S}\right) + \left(\frac{t}{1000000}\right)$$

Solving for the minimum buffer size in the above equation yields the following equation which gives the minimum buffer size:



- 8 -

$$B \geq \left( \frac{DS}{S-2D} \right) \times \left( \frac{t}{1000000} \right)$$

Referring to Fig. 10, an information delivery system 1000 according to one embodiment includes a content creator 1012, a transport operator system 1014, and a plurality of receivers 1016. The receivers 1016 may be located at various receiving sites, including homes, offices, entertainment facilities, or other locations. The content creator 1012 originates enhancement data (or other types of ancillary information) and television content (or other types of content including A/V content) communicated to the transport operator system 1014 over link 1024. Enhancement data may include graphics (e.g., web pages, multimedia information, or other digital data files), presentation layout, and synchronization information. Other types of ancillary information may include program subtitles, closed caption messages, emergency messages, and program guide information. The combination of the enhancement data or ancillary information and A/V content may be referred to as enhanced content.

The transport operator system 1014 provides an enhanced content delivery infrastructure that may include terrestrial, cable, satellite, or other types of transmission facilities (either analog or digital). The A/V content and enhancement data may be transmitted over a transport medium 1022, which may be a terrestrial, cable, satellite, or other type of link, to the receivers 1016. Figure 10 illustrates the transport medium 1022 as a satellite link. The receivers 1016 may include televisions, set-top boxes, personal computers, or other types of systems adapted to receive A/V content and associated enhanced content.

A transmitter 1112 transmits video and enhanced content to a receiver 1114 in accordance with one embodiment of the present invention, as shown in Figure 11. The video and enhanced content may then be displayed on the display 1116. Alternatively, synchronism can be provided between the enhanced content and the video as indicated at 1118 and both the enhanced content and video may be stored as indicated at 1120.

In the systems which include enhanced content, broadcast pause and resume for time shifted playback may be provided for both the audio and video information and enhanced content. This may mean replaying the enhanced content if the enhanced content was previously activated during the original play or it may mean playing back the original video information and allowing the user, during the replay, to select for viewing the enhanced content.

Random access to selected points within a compressed video stream may be provided through a key frame mechanism in one embodiment of the present invention. A key frame or an intra-coded (I) frame is a complete still frame of video. Other frames, such as the bi-directional (B) or predicted (P) frames, in compressed video are represented as differences from surrounding frames in a Motion Pictures Experts Group (MPEG) system. MPEG-2 refers to International Organization for Standardization (ISO) and International Electrotechnical Commission (IEC) Standard 13818-1 (Systems), 13818-2 (video), 13818-3 (audio) and 13818-4 (compliance) (1994). Since key frames are self contained, it is possible to resume the playback from any key frame in the stream without additional processing.

Random access within an arbitrary stream of hypertext mark up language (HTML) commands is difficult. Thus, key frames may be provided to encompass the HTML data and other enhanced content. An instance of the Web browser software may read a received data stream, process the commands, and render the data to an off screen buffer. As shown in Figure 12, at specified time intervals a snapshot 1202 is taken of the off screen Web browser buffer 1200. The snapshot 1202 may optionally be compressed and stored with the internal state variables 1204 of the browser software to create a software key frame 1206. The software key frame 1206 may then be stored on a hard disk 1208, for example, in synchronization with the A/V content.

As a result, the enhanced content can be played back from any point in the recorded stream. When playback is resumed, the state variables are reloaded into the instance of the browser, and on-screen browser windows are refreshed from the software key frame. Processing of the enhanced video stream can then resume from the indicated point in the video stream.

In operation, software 1300 may cause the incoming stream, including enhanced content and video information, to be read by the browser as it is received, as shown at block 1302 in Figure 13. The content is read (block 1306). The browser internal state is the result of reading the enhanced content stream to a certain point. Then, to recreate the state of the stream at a particular time, a software key frame allows reconstruction of the frame without dependencies on what came before or after in the flow (block 1308). The browser has an internal state based on processing commands as received. Thus, an earlier defined point of the browser state may be reloaded upon command from the user.

- 10 -

When the stream is replayed, the enhanced features that were activated when the enhanced content was originally are displayed as part of the audio video stream. If no enhanced content was displayed originally, the hot spots or links to the enhanced content are exposed to allow the viewer to select the enhanced content during replay if desired. In some  
5 embodiments of the present invention, the so-called transport type B mechanism may be utilized wherein the enhanced data is synchronized to the video. See Enhanced Content Specification, Advanced Television Enhancement Forum (available at [www.atvef.com](http://www.atvef.com)). However, the present invention may also be applied to the transport type A scenario wherein uniform resource locators (URLs) are provided to link to the enhanced data from the video  
10 information.

In some instances of the present invention, synchronization between the enhanced content and the video information may be provided with the transmission. A time code track may be utilized for providing identifiers to synchronize video and enhanced content. The time code may be provided in each of the packets of video and enhanced content data to  
15 provide synchronization in a given packet. The time code may then be utilized to control the separate multiplexing of video and enhanced content and its recombination as needed, for example, for display. Alternatively, the video packets and enhanced content packets may be parsed and separated but the time codes may be utilized to bring them back together for display.

20 Web browsers typically maintain a memory or disk-based cache of the most recently displayed Web pages and graphics. Thus, if each software key frame contained the entire contents of the browser cache, key frames may become very large. However, the Web browser need not cache a separate copy of the enhanced content or HTML object. Instead, since the original video plus enhanced content stream has been recorded, the Web browser  
25 may cache only a reference to the location of the HTML object or enhanced data in the previously recorded stream. Then there is no need to empty the Web browser's cache until the entire recorded program is removed from that storage.

The software key frame may be a snapshot of the local state variables of the browser rather than the entire contents of the browser cache in one embodiment of the invention. The  
30 browser state includes screen buffers, a stack and a heap. Thus, objects of the browser cache are not captured but instead references are captured, for example to time codes to provide offsets into the data stream to find the recorded information.

- 11 -

The video data may define a video frame or a plurality of video frames. Each video frame may be identified (if more than one video frame is involved) by a frame identifier. The frame identifier identifies each frame of a plurality of video frames which, for example, may make up a video presentation such as a movie, a television program, or a web site as  
5 examples.

One convenient frame identifier is the time code in accordance with one of a variety of industry standards including the Society of Motion Picture and Television Engineers (SMPTE). Conventionally, the time codes are utilized to enable synchronization between audio and video tracks. Another time code is the vertical interval time code (VITC). The  
10 VITC may be advantageous in some applications because it can be read even when the medium storing the video is paused.

The SMPTE time code is a broadcast standard time which may be recorded in the format HH:MM:SS;FF, where FF is a frame number between 00 and 29, HH is a two-digit code for hours, MM is a two-digit code for minutes and SS is a two-digit code for seconds.  
15 Assuming a frame rate of 30 frames per second, the SMPTE time code may identify every frame of a video sequence such as a movie, a television program or other video information.

While the present invention, in one embodiment, uses a time code to identify a given frame, the present invention is in no way limited to the use of time codes. The time code is simply a convenient way to identify one of a plurality of frames. Other techniques may also  
20 be utilized to identify each of the frames including simply providing each frame with a sequential identifier.

Thus, referring to Figure 14, a packet 1422 with a video key frame 1444 and a software key frame 1426 may include a single time code 1428, in accordance with one embodiment of the present invention. The video key frame 1424 may be utilized to access  
25 the video storage 1432 as indicated at 1430. Similarly, the software key frame may be provided to reference, as indicated at 1434, the browser cache 1436 without requiring that the entire browser cache be stored. This saves unnecessary processing and preserves storage space.

In accordance with another embodiment of the present invention, shown in Figure 15,  
30 the time code 1428a may be associated with a video key frame 1424 as a single packet 1500. At the same time, a time code 1428b may be associated with a software key frame 1426 as a separate packet 1502. The video key frame may then be utilized to access the video storage

- 12 -

1432. The software key frame 1426 may be utilized to access the browser cache 1436. The time codes 1428a and 1428b may be the same in accordance with one embodiment of the present invention in order to enable the corresponding video key frame 1424 to be linked to the corresponding software key frame 1426, for example for replay. As a result, both the  
5 enhanced content and the video information may be replayed using a random access memory.

While the present invention has been described with respect to a limited number of embodiments, those skilled in the art will appreciate numerous modifications and variations therefrom. It is intended that the appended claims cover all such modifications and variations as fall within the true spirit and scope of this present invention.

10           What is claimed is:

- 13 -

- 1           1.     A method comprising:  
2                 receiving video and enhanced content information;  
3                 storing said video information for subsequent playback in a random access  
4 memory; and  
5                 storing said enhanced content information for subsequent playback.
  
- 1           2.     The method of claim 1 further including storing said enhanced content  
2 information in a random access memory.
  
- 1           3.     The method of claim 2 including storing said video information and said  
2 enhanced content information in a hard disk drive.
  
- 1           4.     The method of claim 1 including providing a time code to synchronize said  
2 video information with said enhanced content information.
  
- 1           5.     The method of claim 4 including providing separate packets for video  
2 information and the enhanced content information and including a time code in each packet.
  
- 1           6.     The method of claim 4 including providing a packet including video  
2 information and enhanced content information.
  
- 1           7.     The method of claim 1 including deriving a key frame from said enhanced  
2 content information.
  
- 1           8.     The method of claim 7 including deriving a key frame which enables the  
2 enhanced content information to be replayed.
  
- 1           9.     The method of claim 8 including storing the contents of a web browser buffer.
  
- 1           10.    The method of claim 9 wherein deriving a key frame includes storing a pointer  
2 to the stored enhanced content information.

- 1           11.    An article comprising a medium for storing instructions that cause a  
2 processor-based system to:  
3                    receive video and enhanced content information;  
4                    store said video information in a random access memory for subsequent  
5 playback; and  
6                    store said enhanced content information for subsequent playback.
- 1           12.    The article of claim 11 further storing instructions that cause a processor-  
2 based system to store said enhanced content information in a random access memory.
- 1           13.    The article of claim 12 further storing instructions that cause a processor-  
2 based system to store said video information and said enhanced content information in a hard  
3 disk drive.
- 1           14.    The article of claim 11 further storing instructions that cause a processor-  
2 based system to provide a time code to synchronize said video information with said  
3 enhanced content information.
- 1           15.    The article of claim 14 further storing instructions that cause a processor-  
2 based system to provide a separate packet for video information and the enhanced content  
3 information and to provide a time code for each packet.
- 1           16.    The article of claim 14 further storing instructions that cause a processor-  
2 based system to provide a packet including video information and enhanced content  
3 information.
- 1           17.    The article of claim 11 further storing instructions that cause a processor-  
2 based system to derive a software key frame from said enhanced content information.
- 1           18.    The article of claim 17 further storing instructions that cause a processor-  
2 based system to derive a software key frame which enables enhanced content information to  
3 be replayed.

1           19.    The article of claim 18 further storing instructions that cause a processor-  
2 based system to store the contents of a web browser buffer.

1           20.    The article of claim 19 further storing instructions that cause a processor-  
2 based system to store a pointer to the stored enhanced content information.

1           21.    A system comprising:  
2                a processor; and  
3                a random access memory, coupled to said processor, to store video  
4 information and enhanced content for replay of any portion of the video information and  
5 content information.

1           22.    The system of claim 21 including storage coupled to said processor, said  
2 storage storing a program that causes the processor to store video information and enhanced  
3 content information for subsequent random access playback.

1           23.    The system of claim 22 wherein said program causes said enhanced content  
2 information to be stored as a software key frame.

1           24.    The system of claim 23 wherein said program causes said processor to store  
2 the contents of a web browser buffer.

1           25.    The system of claim 23 wherein said program causes a processor to derive a  
2 software key frame storing a pointer to the stored enhanced content information.

1           26.    The system of claim 21 wherein said random access memory is a hard disk.



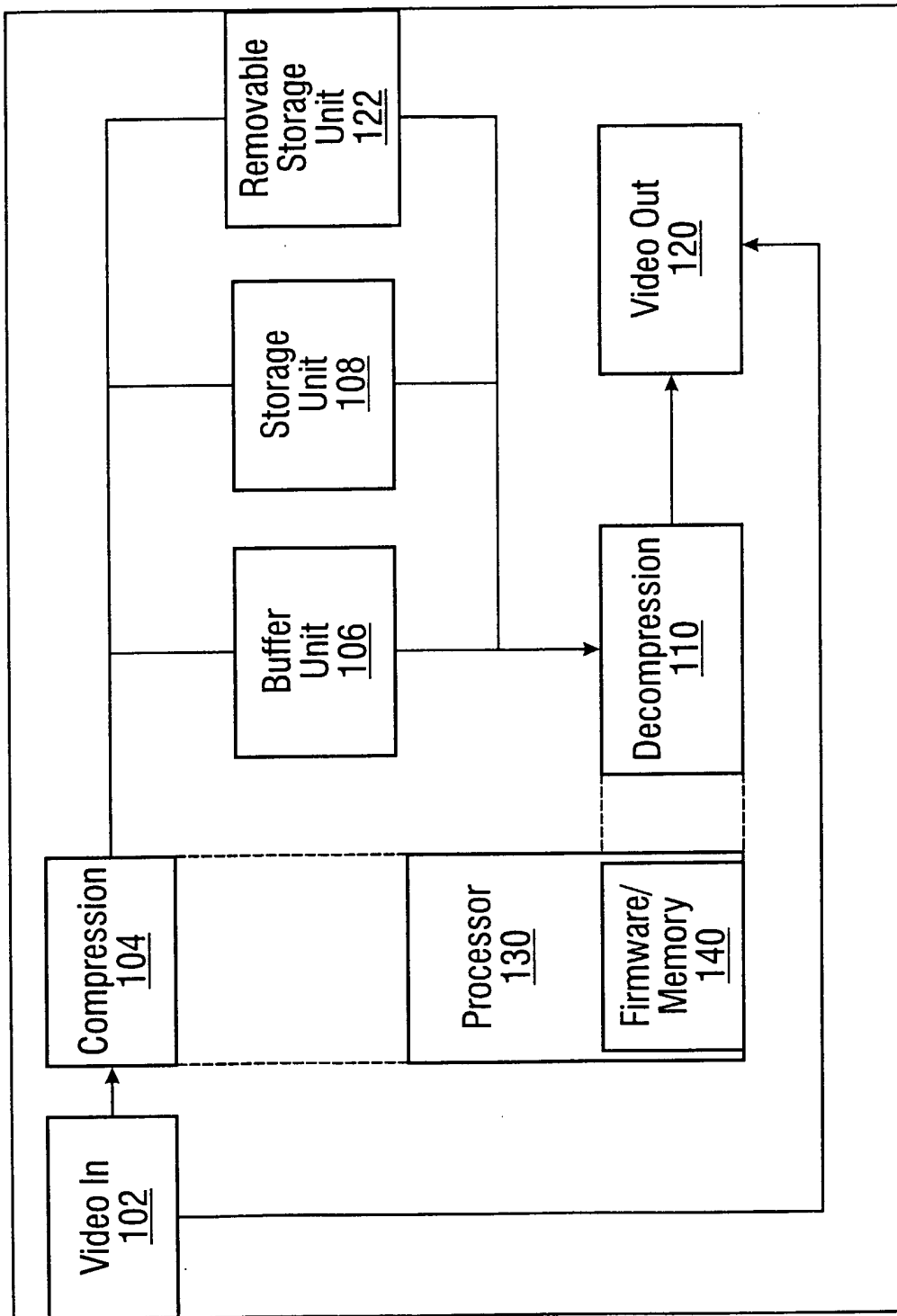

FIG. 1

2/12

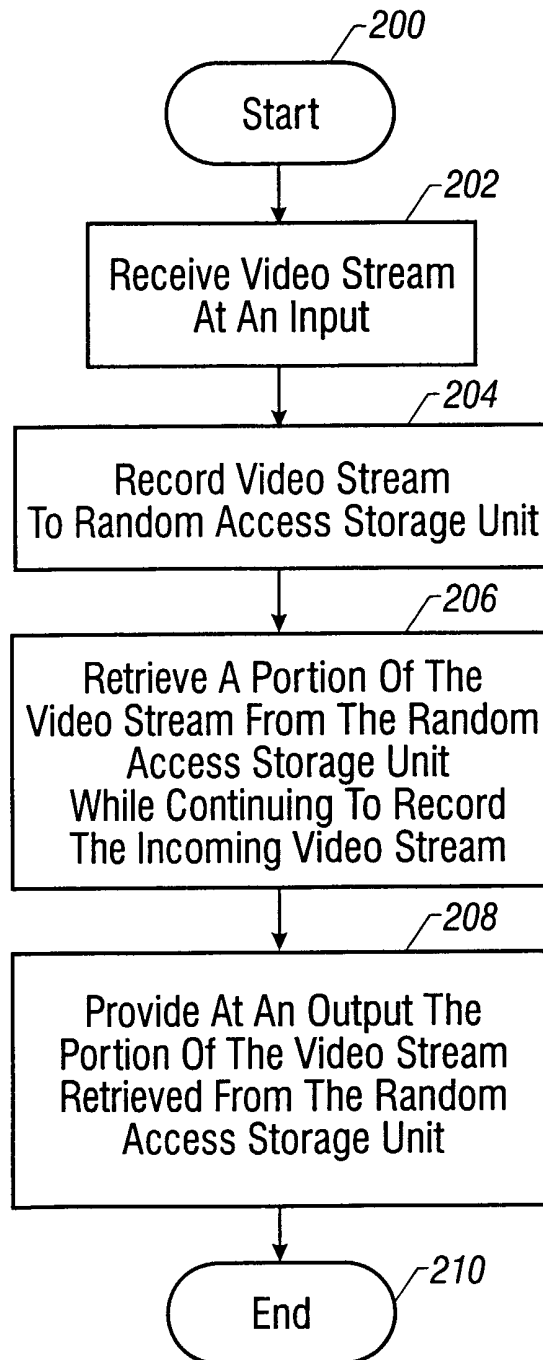

FIG. 2

3/12

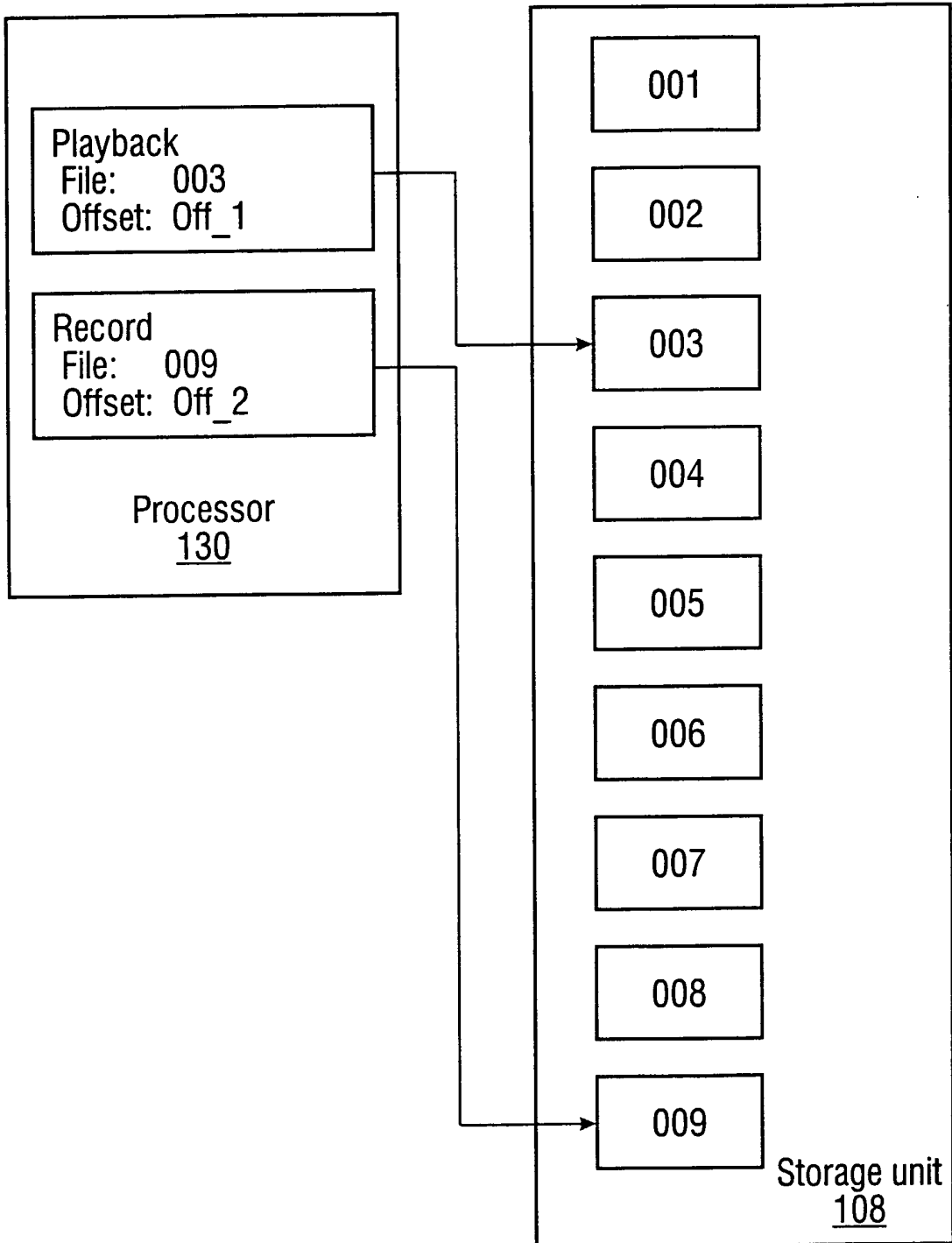

FIG. 3

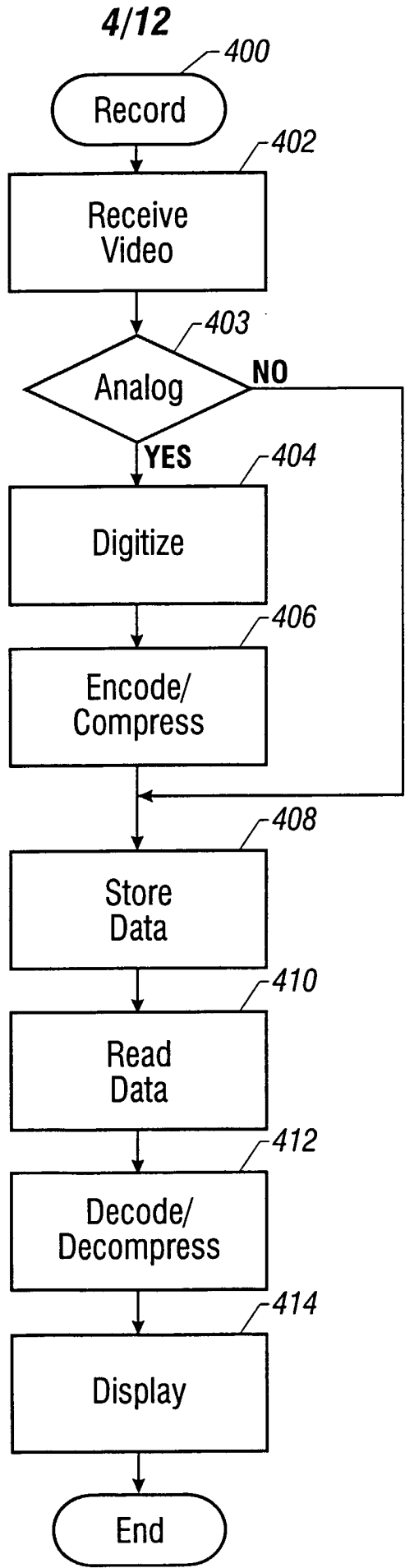

FIG. 4

5/12

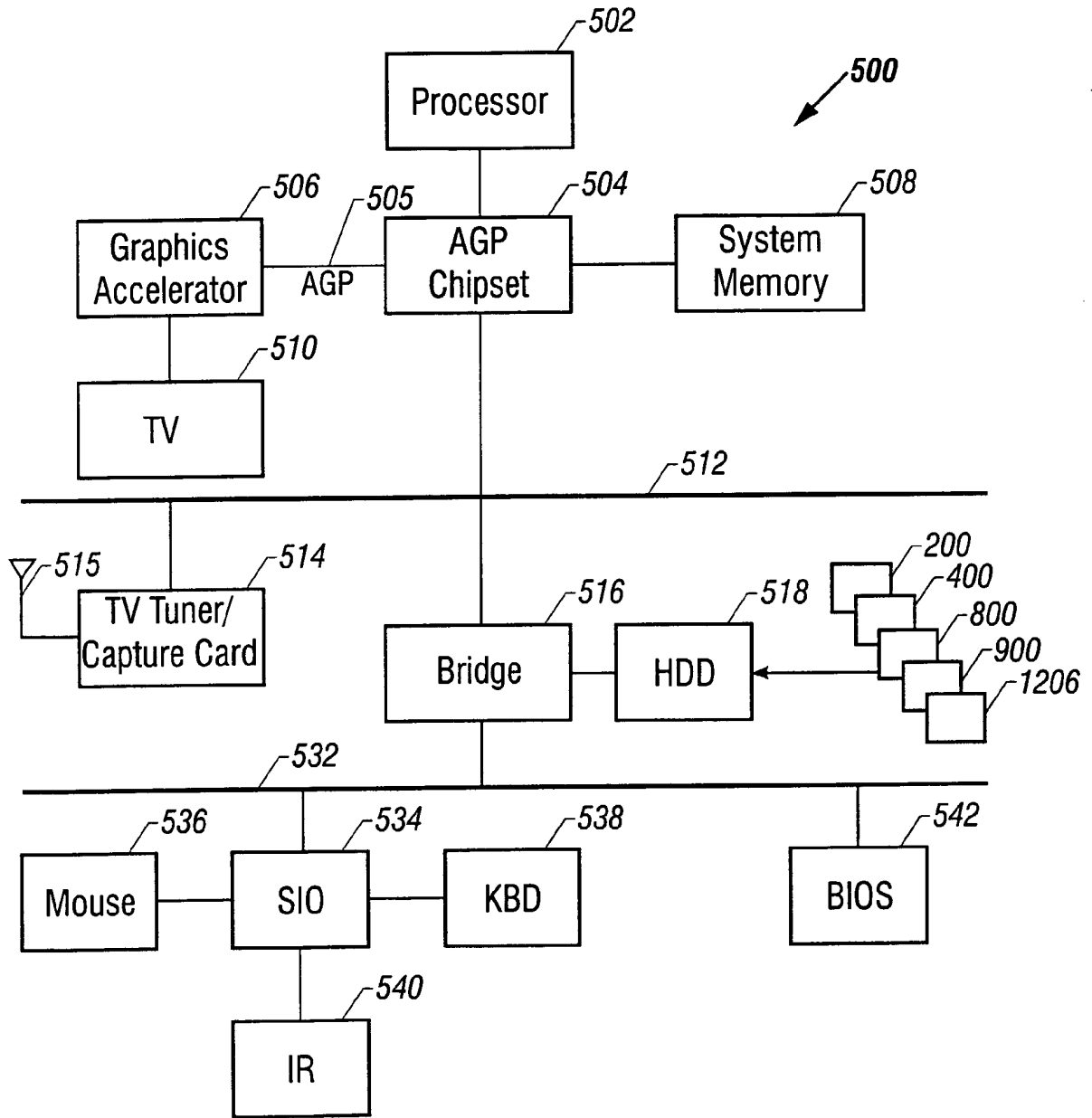
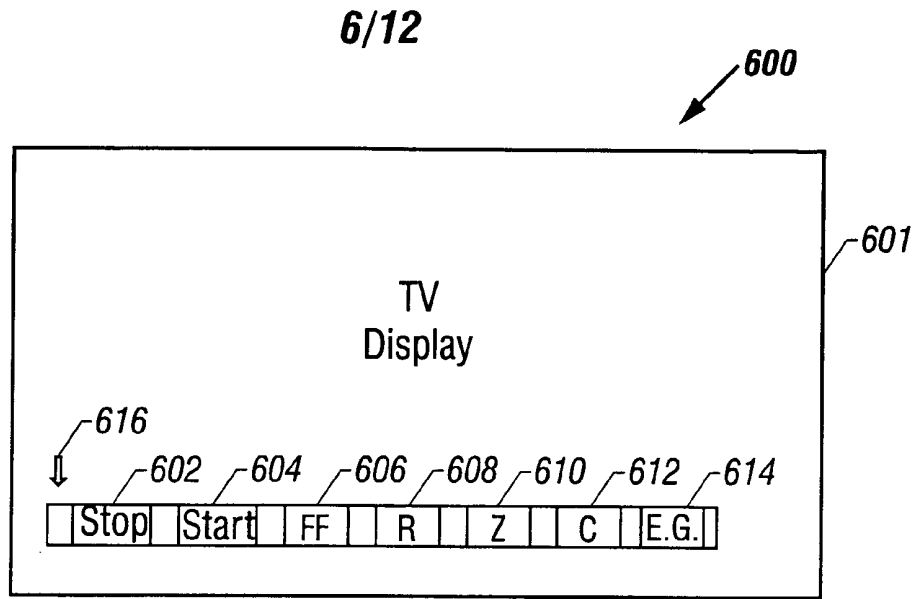
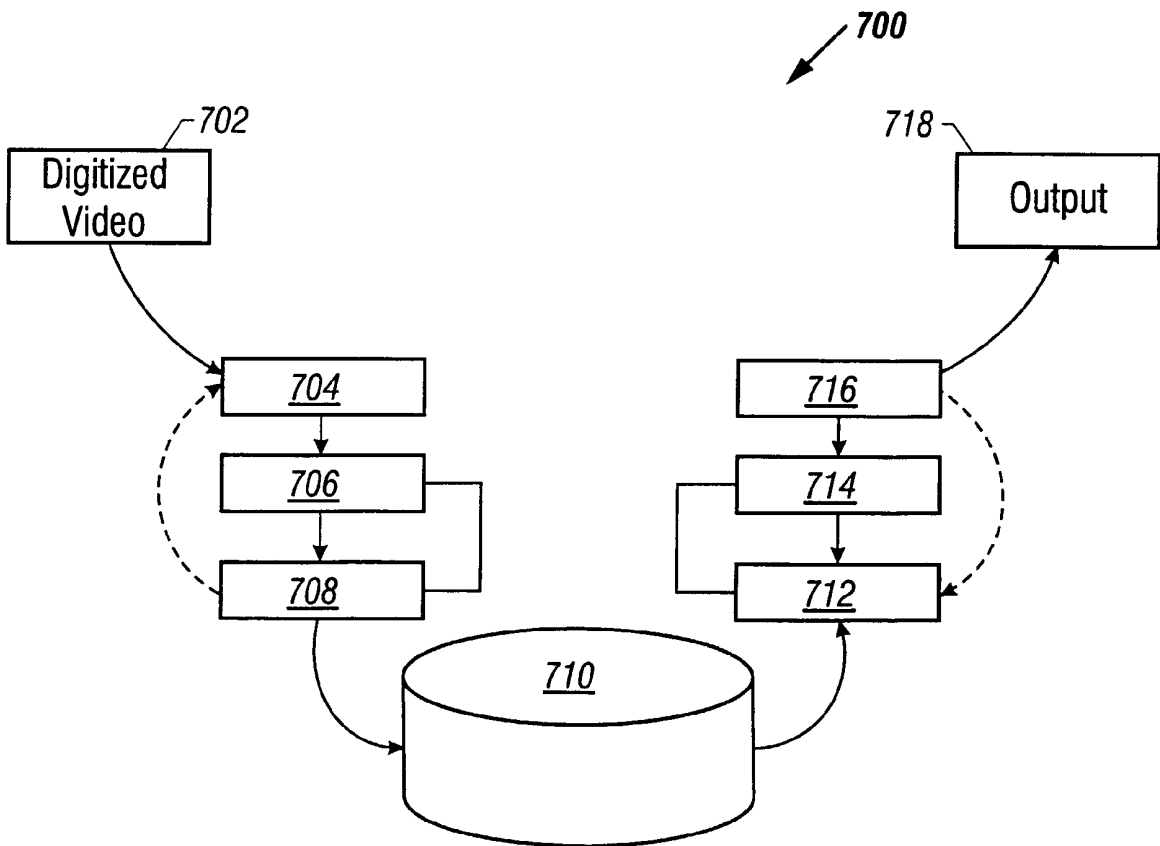

FIG. 5



**FIG. 6**



**FIG. 7**

7/12

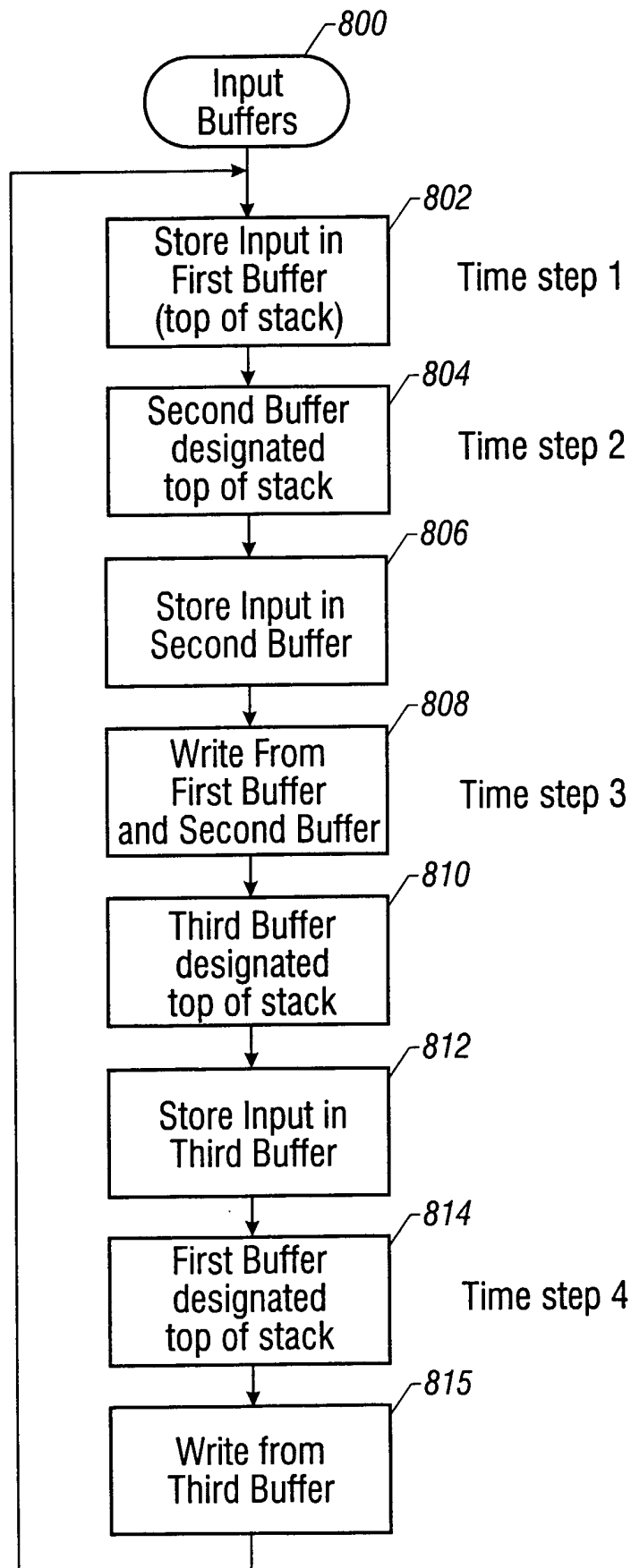
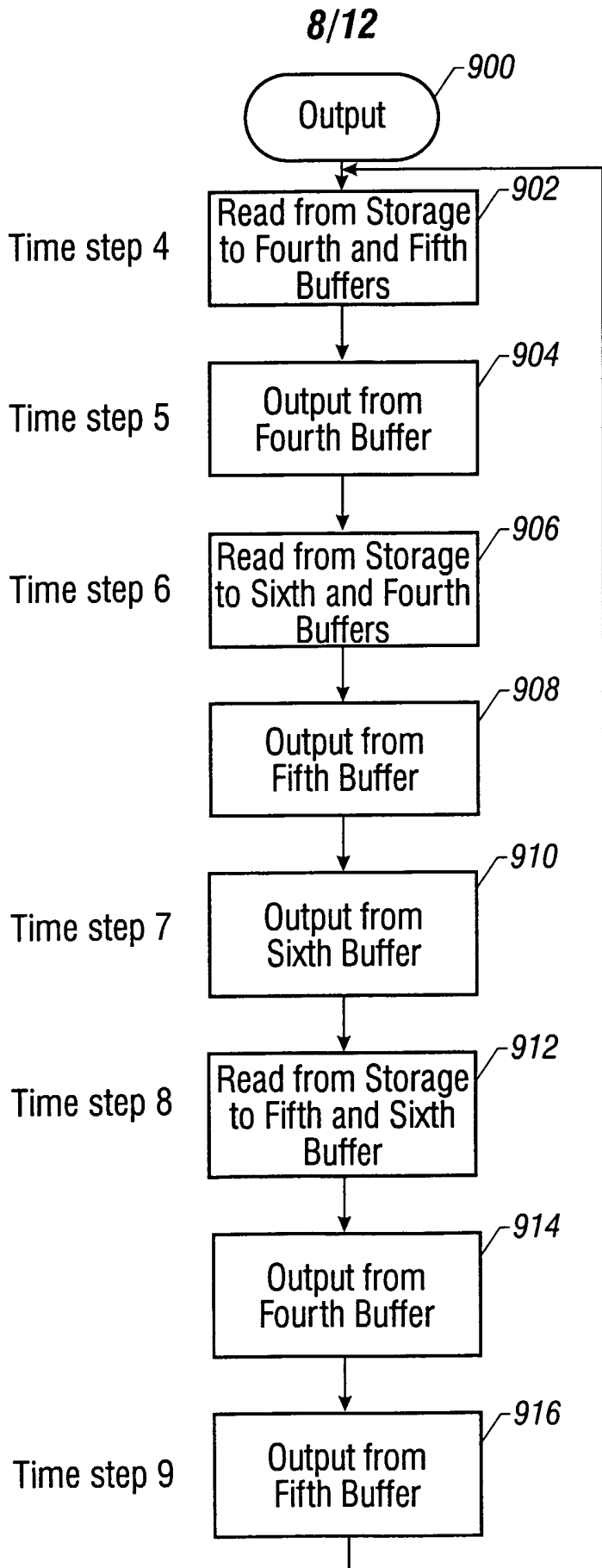

FIG. 8



**FIG. 9**



9/12

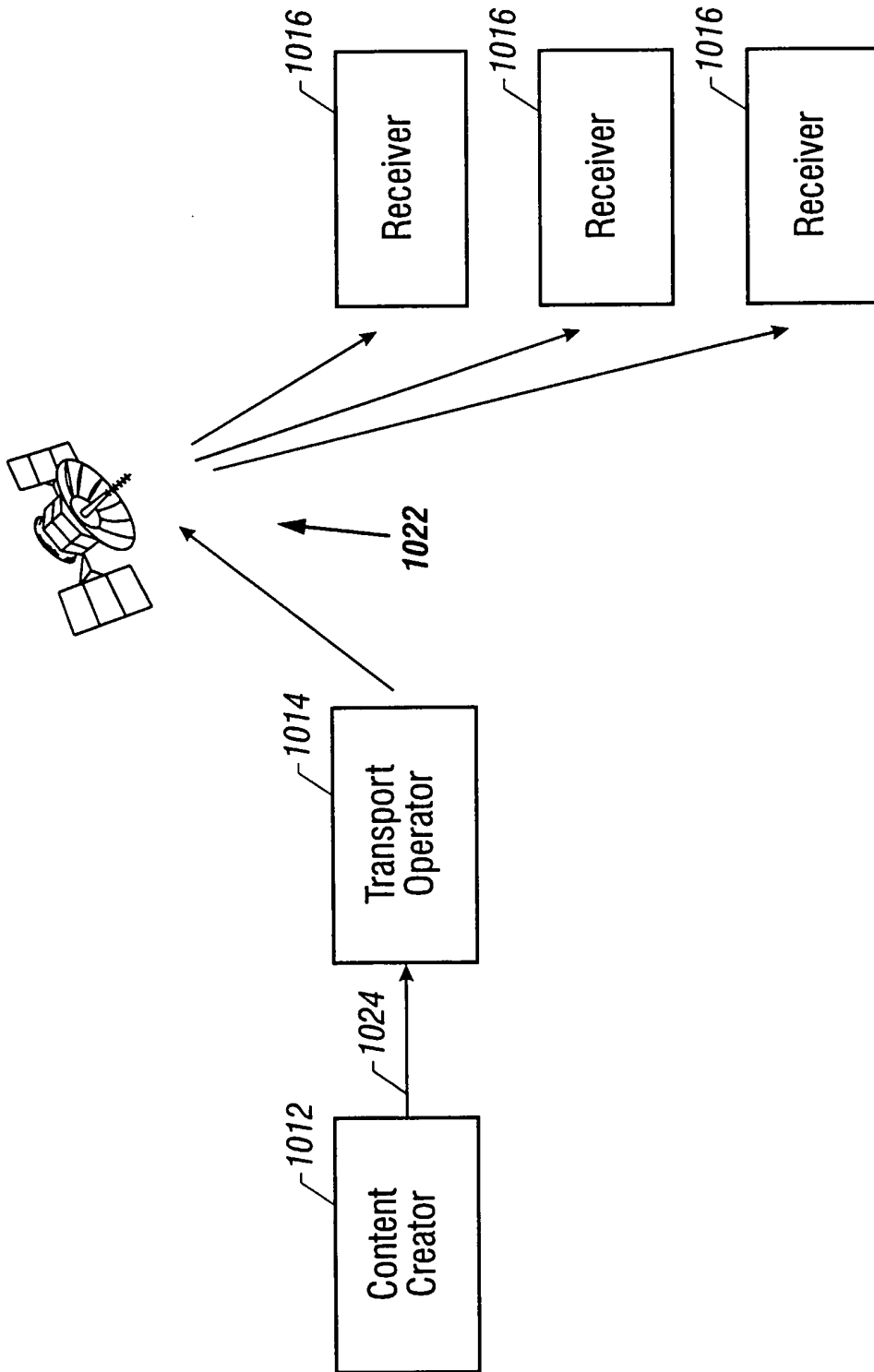
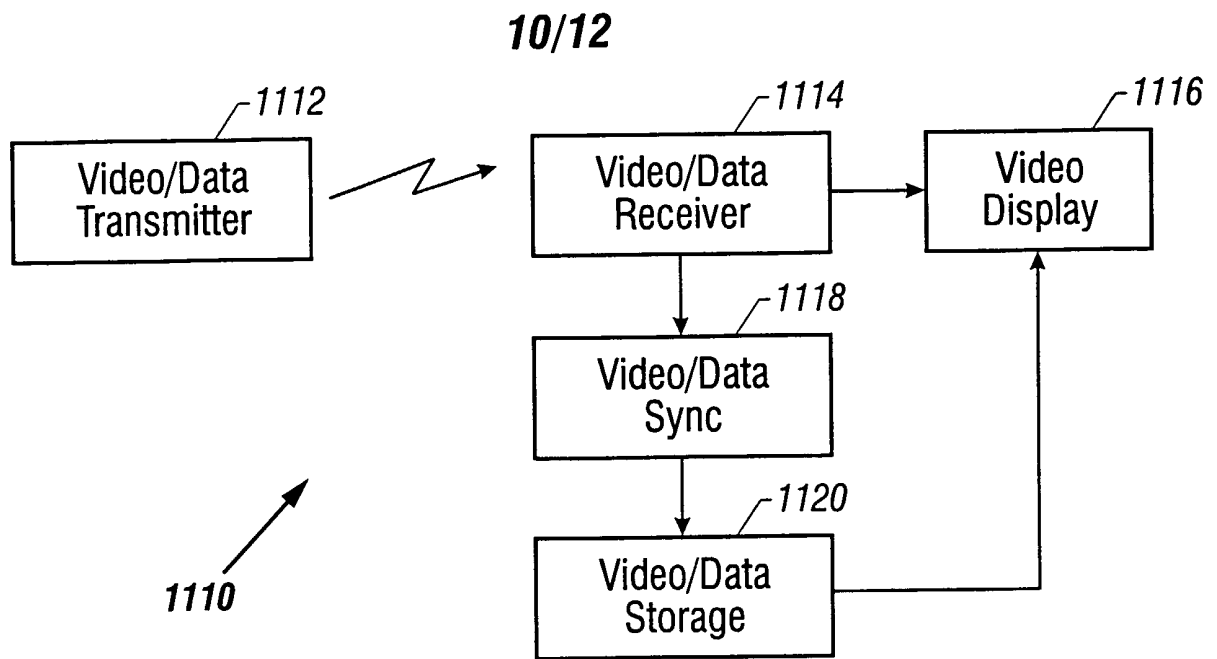
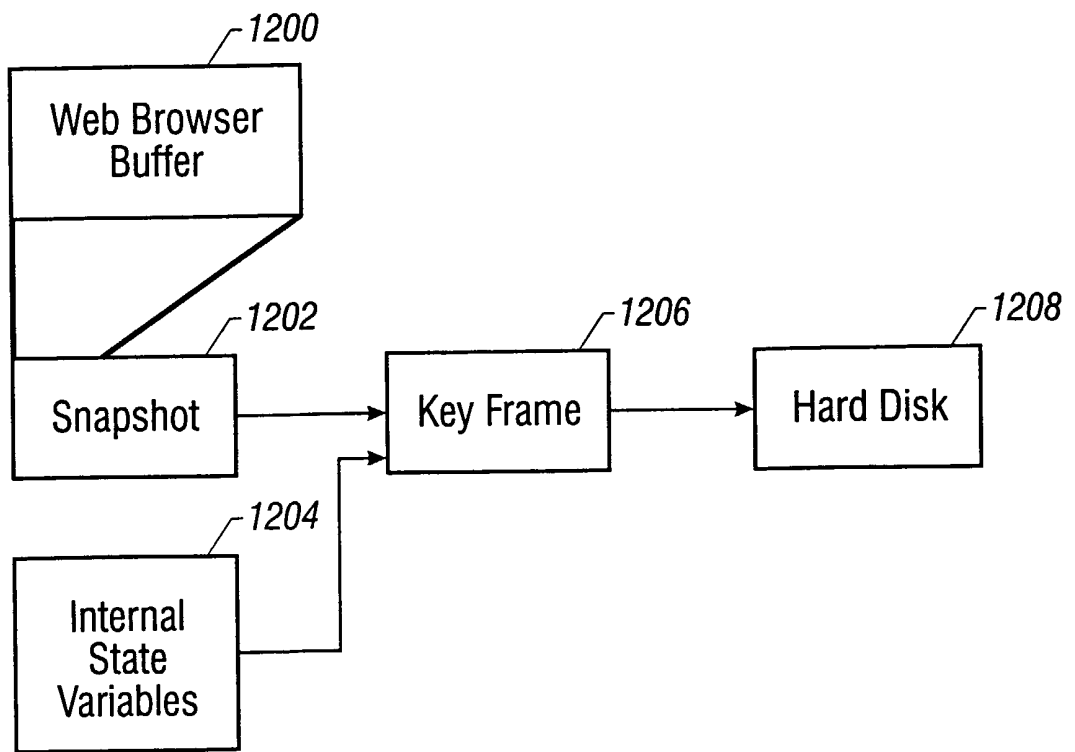

FIG. 10



**FIG. 11**



**FIG. 12**

11/12

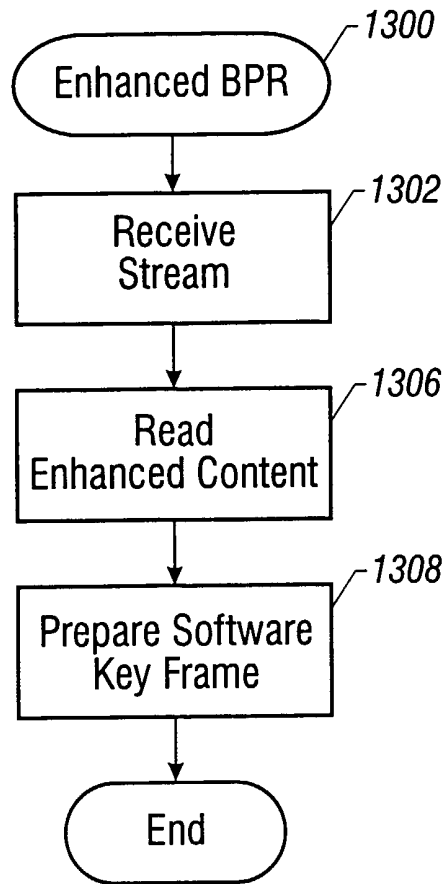

FIG. 13

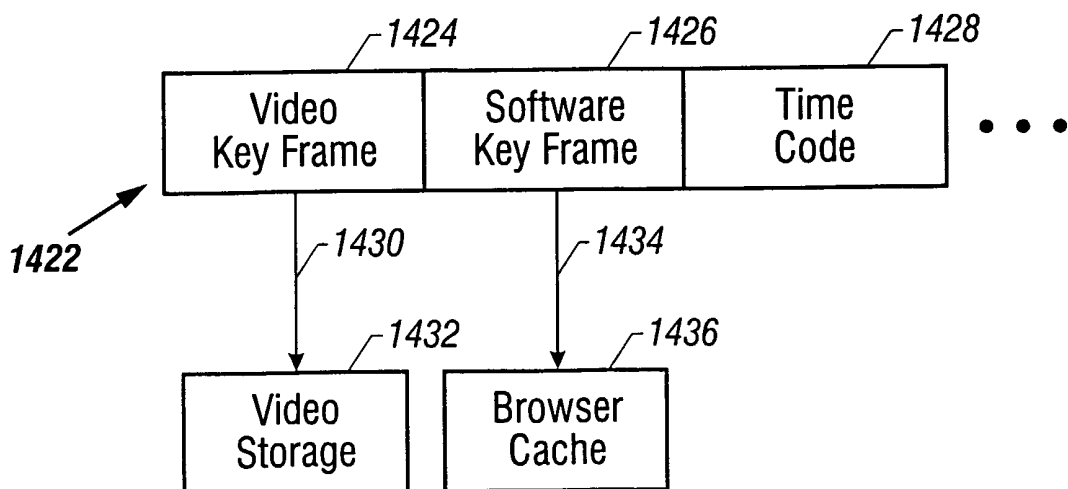

FIG. 14

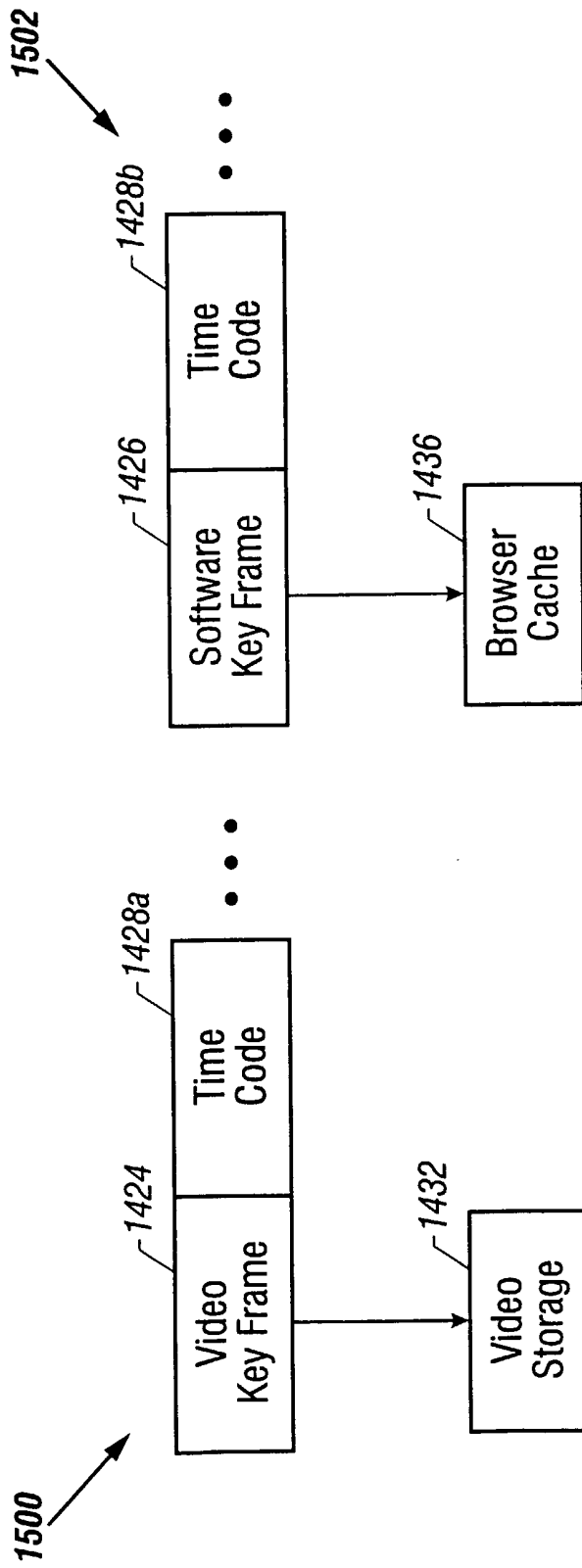

FIG. 15