

Jan. 13, 1959

H. H. PRYOR
VENDING MACHINE

2,868,414

Filed July 16, 1956

3 Sheets-Sheet 1

FIG. 1.

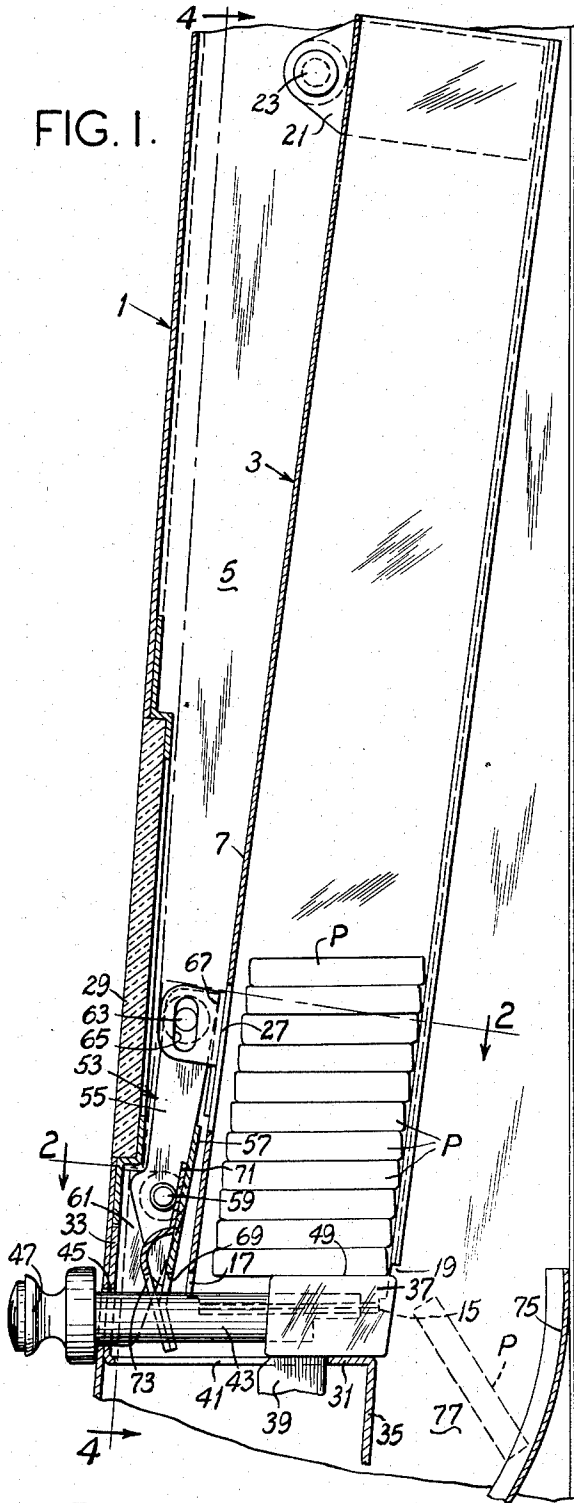
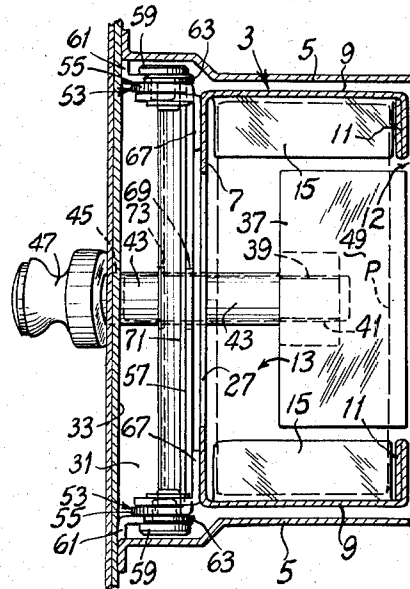

FIG. 2.



Harry H. Pryor,
Inventor.
Koenig and Pope,
Attorneys.

Jan. 13, 1959

H. H. PRYOR
VENDING MACHINE

2,868,414

Filed July 16, 1956

3 Sheets-Sheet 2

FIG. 3.

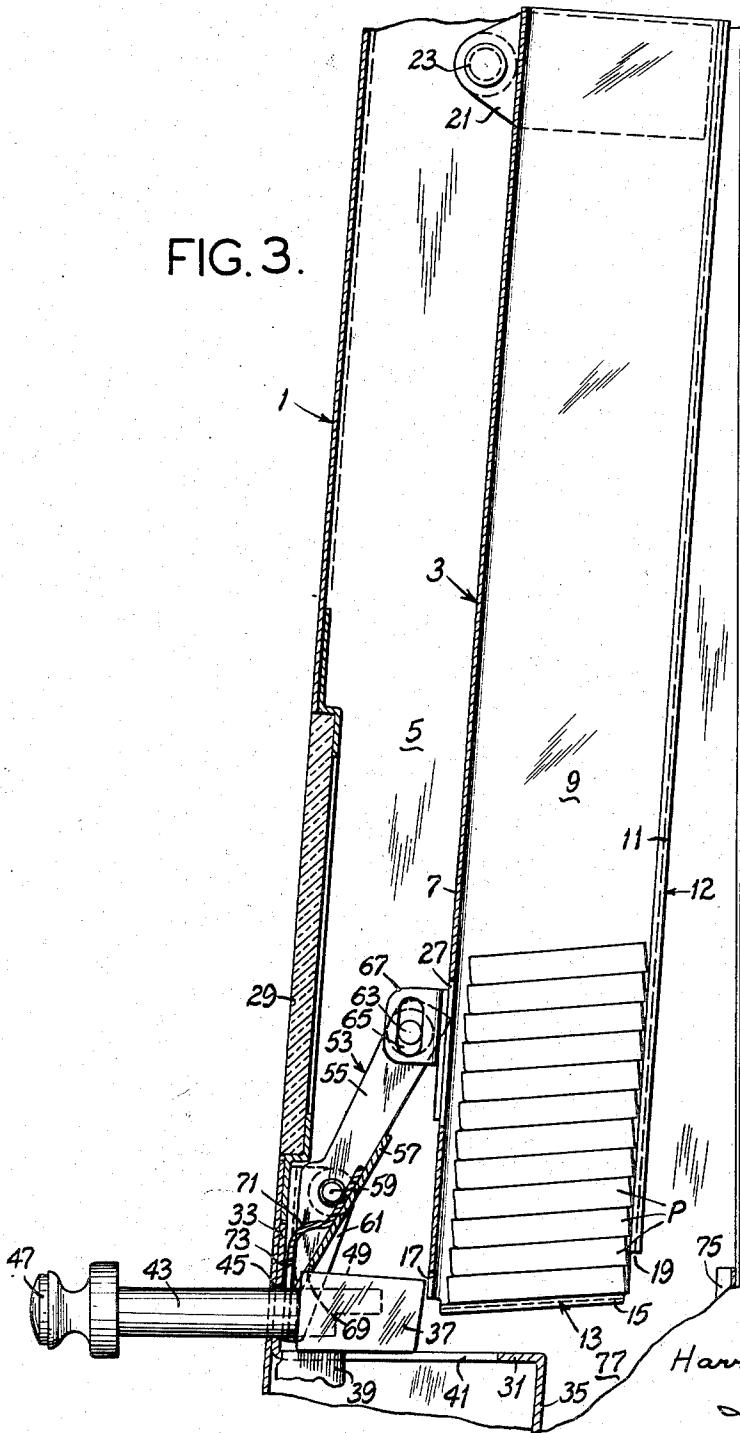

Harry H. Pryor,
Inventor.
Koenig and Pope,
Attorneys.

Jan. 13, 1959

H. H. PRYOR
VENDING MACHINE

2,868,414

Filed July 16, 1956

3 Sheets-Sheet 3

FIG. 4.

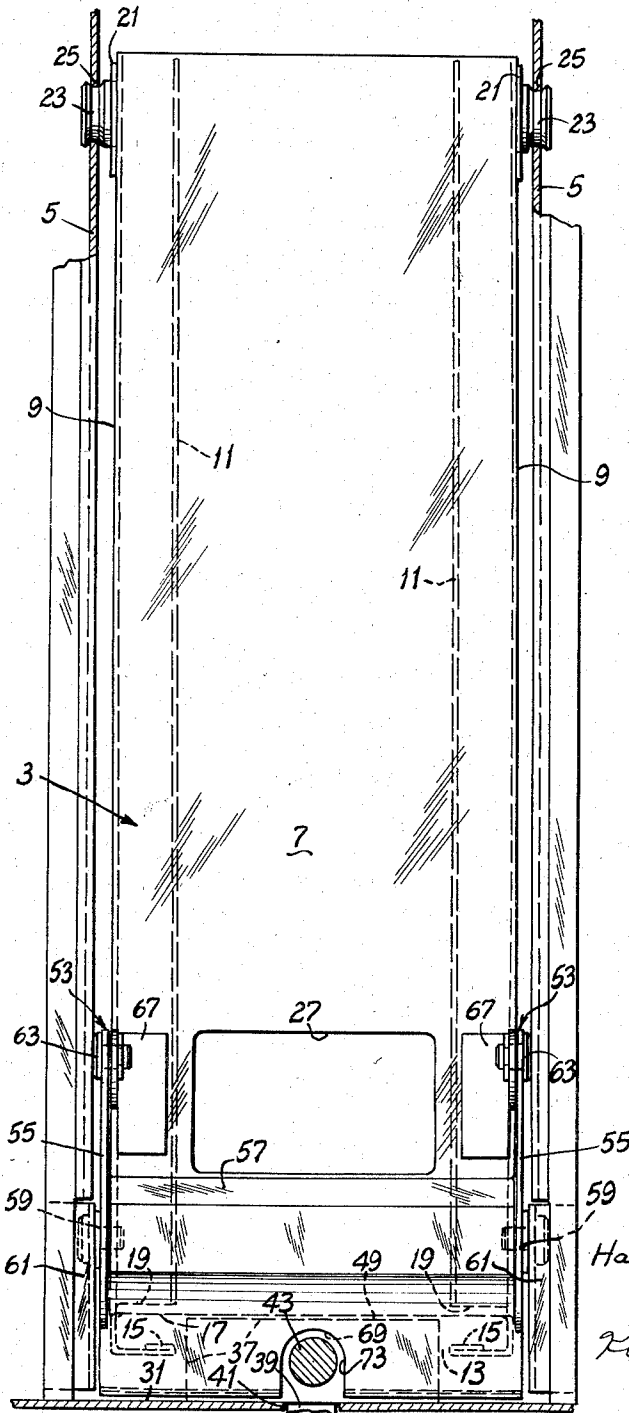

Harry H. Pryor,
Inventor.
Koenig and Pope,
Attorneys.

1

2,868,414

VENDING MACHINE

Harry H. Pryor, St. Louis, Mo., assignor to National Vendors, Inc., St. Louis, Mo., a corporation of Missouri

Application July 16, 1956, Serial No. 598,165

3 Claims. (Cl. 221—188)

This invention relates to vending machines, and more particularly to magazine-type article dispensing apparatus for use in a vending machine.

Among the several objects of the invention may be noted the provision of improved apparatus for dispensing articles, such as packages of chewing gum, from a magazine adapted to hold a stack of articles, wherein the magazine is movable and wherein there is provided an ejector for ejecting articles from the magazine, the apparatus being so constructed as to minimize the movement of the magazine; the provision of apparatus of this class in which the minimizing of the movement of the magazine is obtained by means of an arrangement in which the ejector, as well as the magazine, is movable, and in which movement of the ejector effects movement of the magazine in such manner that only a relatively short stroke of the magazine is required to eject an article from the magazine; and the provision of apparatus having the stated features which is of economical construction and reliable in operation. Other objects and features will be in part apparent and in part pointed out hereinafter.

The invention accordingly comprises the constructions hereinafter described, the scope of the invention being indicated in the following claims.

In the accompanying drawings, in which one of various possible embodiments of the invention is illustrated,

Fig. 1 is a vertical cross section of a dispensing apparatus of this invention;

Fig. 2 is a cross section taken on line 2—2 of Fig. 1;

Fig. 3 is a view similar to Fig. 1, illustrating a moved position of parts; and,

Fig. 4 is a cross section taken on line 4—4 of Fig. 1.

Corresponding reference characters indicate corresponding parts throughout the several views of the drawings.

Referring to the drawings, there is indicated at 1 a portion of the front door of the cabinet of a vending machine such as the vending machine shown in U. S. design patent Des. 174,587, dated April 26, 1955. The vending machine is not shown in its entirety since its details are not relevant to this invention. It will suffice to say that the portion of the door shown in the drawings is an inclined panel portion of the front door of a cigarette vending machine cabinet, behind which door there are magazines for packages of cigarettes (not shown). As shown herein, this door is utilized for holding on the inside thereof a movable magazine generally designated 3 for articles such as packages of gum P, the magazine being accessible for loading on opening the door.

More particularly, the magazine is pivotally mounted on the inside of the door 1 for swinging movement in opposite directions in a front-to-back plane in relation to the vending machine. The magazine is positioned between two vertical plates 5 secured to the inside of the door 1. The magazine has a front wall 7, side walls 9 and inwardly directed rear flanges 11, with a substantial space 12 between these flanges to facilitate loading the magazine. The magazine has a slot 13 extending across its

2

bottom end in the front-to-back plane. This slot is bounded by flanges 15 which extend inward from the lower edges of the side walls 9. These flanges 15 constitute ledges for supporting a stack of packages P in the magazine. The lower edge of the front wall 7 of the magazine is spaced above the ledges 15 to provide a bottom front opening 17 for the magazine. The lower edges of the rear flanges 11 of the magazines are spaced above the ledges 15 to provide a transverse discharge opening 19 at the lower rear of the magazine through which the lowermost article of the stack may be ejected. This opening 19 has a height greater than the height of a package P, but less than twice the height of a package.

Arms 21 are secured on the outside of the side walls 9 of the magazine at its upper end. These arms project forward from the magazine and have pivots 23 at their forward ends received in openings 25 in the plates 5, whereby the magazine is pivotally mounted for swinging movement on a horizontal axis in the stated front-to-back plane between the plates 5. With the pivotal axis of the magazine located in front of the magazine as shown, the magazine is gravity-biased (under its own weight and the weight of the articles contained therein) to swing to the retracted forward position shown in Fig. 1. The front wall 7 of the magazine is shown as being provided with a window opening 27. This opening registers with a window 29 provided in the door 1 for observation of the packages P in the magazine.

Below the magazine, there is provided a horizontal plate 31. This has an upwardly extending front flange 33 by means of which it is secured to the door 1, and it is also shown as having a downwardly extending rear flange 35. An ejector 37 is slidable on the plate 31, being guided for reciprocating movement in opposite directions in the stated front-to-back plane by having a downwardly extending projection 39 riding in a slot 41 in the plate 31. A rod 43 extends outward from the ejector 37 through an opening 45 formed in the flange 33 and the door 1, and has a knob 47 fixed on its outer end outward of the panel 1. The ejector assembly consisting of ejector 37, rod 43 and knob 47 normally occupies the rearward retracted position shown in Fig. 1 in which the ejector 37 is located adjacent the rear edge of the plate 31 and in which the knob 47 engages the front of the door 1. The ejector 37 is narrower than the slot 13 in the magazine, and is adapted to move through the slot, its top surface 49 being below the bottom edge of the front wall 7 of the magazine. With the ejector 37 and the magazine 3 in their retracted positions as shown in Fig. 1, the stack of packages P in the magazine bears on the top surface 49 of the ejector 37.

Means is provided operable by the ejector 37 upon forward movement thereof from its rearward retracted position for swinging the magazine 3 rearward away from its retracted position to the advanced position shown in Fig. 3 in which the lower end of the magazine is clear of the ejector 37. This means comprises a lever, designated in its entirety by the reference character 53, pivotally mounted on the door 1 and engageable by the ejector 37 for effecting rearward swinging of the magazine 3 upon pulling out the ejector. More particularly, the lever 53 comprises a pair of side arms each designated 55 connected by an integral web 57. The arms 55 are pivotally connected intermediate their ends as indicated at 59 to brackets 61 mounted on the inside of the door 1 for swinging movement on a horizontal axis transverse to the plane of movement of the magazine 3. The arms 55 at their upper ends are connected to the magazine 3 by means of pins 63 received in elongate slots 65 in brackets 67 secured to the front wall 7 of the magazine.

3

The web 57 of the lever 53 has its upper edge generally at the level of the lower edge of the window opening 27 in the front wall 7 of the magazine for unobstructed viewing of the packages P in the magazine. The web 57 extends downward in front of the ejector 37 and has a notch 69 therein accommodating the rod 43. A reinforcing plate 71 is secured to the web 57, having a notch 73 registering with the notch 69. A curved plate 75 is fixed between the side walls 9 rearward of the flange 35 to define in conjunction with the flange 35 a discharge chute 77.

Operation is as follows:

When the ejector 37 is in the rearward retracted position shown in Fig. 1, the magazine 3 hangs down in its retracted forward position, as shown in Fig. 1. The stack of packages P in the magazine 3 is supported in a raised position by the ejector 37. On pulling out the knob 47, with the resultant movement of the ejector 37 to the advanced position shown in Fig. 3, the ejector 37 engages the lower portion of the web 57 of the lever 53 and swings the lever 53 in clockwise direction from the position shown in Fig. 1 to the position shown in Fig. 3. The lever, in rotating clockwise, swings the magazine in counterclockwise direction from the position shown in Fig. 1 to the position shown in Fig. 3 wherein the lower end of the magazine is moved rearward clear of the ejector 37. The stack of packages P in the magazine drops down upon the ledges 15.

Now, when the ejector 37 is pushed rearward back to its retracted position, its rearward face engages the lowermost package P of the stack and pushes this package out through the discharge opening 19. The discharged package (illustrated in dotted lines in Fig. 1) drops out through the chute 77 formed by plate 75 and flange 35. Upon the return of the ejector 37 to its rearward retracted position from the forward position shown in Fig. 3, the ejector moves away from the web 57 of lever 53. This permits the magazine 3 to return to the retracted position shown in Fig. 1 under its gravity bias. When the magazine returns to its retracted Fig. 1 position, the lever 53 is returned to its retracted Fig. 1 position. Thus, return of the ejector 37 to retracted position not only ejects the lowermost package, but effects return of the magazine 3 and lever 53 to retracted position for the next dispensing operation.

From the above, it will be observed that basically the arrangement is such as to provide for movement of the magazine in the direction opposite to that of the movement of the ejector. This makes it possible to minimize the range of swinging movement of the magazine. A comparison of Figs. 1 and 3 will show that the travel of the lower end of the magazine for the particular construction shown is less than one-half the front-to-back dimension of the magazine (and less than one-half the front-to-back dimension of a package P). The apparatus may therefore be accommodated in a relatively small space, such as on the inside of the door of a cigarette vending machine.

In view of the above, it will be seen that the several objects of the invention are achieved and other advantageous results attained.

4

As various changes could be made in the above constructions without departing from the scope of the invention, it is intended that all matter contained in the above description or shown in the accompanying drawings shall be interpreted as illustrative and not in a limiting sense.

I claim:

1. A vending machine comprising a cabinet, a magazine in the cabinet adjacent the front of the cabinet for holding a stack of articles, means pivotally mounting the magazine in the cabinet adjacent one end of the magazine constituting its upper end for swinging movement in forward and rearward direction about a horizontal axis, said magazine being adapted for gravity feed of articles toward its other and lower end, said magazine having a rear discharge opening at its lower end transverse to the direction of its movement through which the lowermost article in the stack may be ejected, said magazine having a slot extending in the direction of its movement traversing its lower end, said magazine being biased to swing forward to a retracted position, an ejector mounted for reciprocation in forward and rearward directions through said slot between a rearward retracted position and a forward position, a rod extending outward from the ejector through an opening in the front of the cabinet and having a knob on its outer end adapted to be grasped by a purchaser for pulling the rod and the ejector forward and for pushing them rearward, and means operable by the ejector upon forward movement thereof by a purchaser from its retracted position and acting on the magazine for swinging said magazine rearward away from its retracted position to move its lower end clear of the ejector, the magazine swinging forward back to its retracted position under its bias upon return of the ejector rearward to retracted position.

2. A vending machine as set forth in claim 1 wherein said ejector-operable means comprises a lever pivotally mounted in the cabinet for swinging movement on a transverse horizontal axis in front of the magazine, the lower end of the lever being located in the path of the ejector for engagement by the ejector as the ejector is moved forward to move the upper end of the lever rearward, the upper end of the lever being engageable with the magazine for swinging the magazine rearward upon such rearward movement of the upper end of the lever.

3. A vending machine as set forth in claim 1 wherein the magazine mounting means is located forward of the magazine so that the magazine is gravity-biased to swing forward to its retracted position.

References Cited in the file of this patent

UNITED STATES PATENTS

55	491,323	Slater	Feb. 7, 1893
	1,196,103	Giles	Aug. 29, 1916
	2,201,277	Whitted	May 21, 1940
	2,521,458	Huheey et al.	Sept. 5, 1950

FOREIGN PATENTS

60	94,903	Germany	Nov. 4, 1897
	230,467	Germany	Jan. 26, 1911